



EMM5077VU

C-Band Power Amplifier MMIC

FEATURES

- High Output Power: Pout = 31.0 dBm (Typ.)
- High Linear Gain: GL = 26 dB (Typ.)
- Broad Band: 3.4 to 5.0 GHz
- Impedance Matched Zin/Zout = 50ohm
- Small Hermetic Metal-Ceramic SMT Package(VU)

DESCRIPTION

The EMM5077VU is a power amplifier MMIC that contains a two stage amplifier, internally matched, for standard communications band in 3.4 to 5.0GHz frequency range. SEDI's stringent Quality Assurance Program assures the highest reliability and consistent performance.

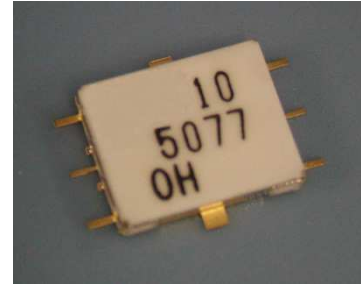

ABSOLUTE MAXIMUM RATING

Item	Symbol	Rating	Unit
Drain-Source Voltage	V _{DD}	10	V
Gate-Source Voltage	V _{GG}	-3	V
Input Power	P _{in}	+26	dBm
Storage Temperature	T _{stg}	-55 to +125	deg.C

RECOMMENDED OPERATING CONDITIONS

Item	Symbol	Condition	Unit
Drain-Source Voltage	V _{DD}	=< 6	V
Input Power	P _{in}	=<10	dBm
Operating Case Temperature	T _C	-40 to +85	deg.C

ELECTRICAL CHARACTERISTICS (Case Temperature Tc=25deg.C)

Item	Symbol	Test Conditions	Limits			Unit
			Min.	Typ.	Max.	
Frequency Range	f	VDD=6.0V	3.4	-	5.0	GHz
Output Power at 1dB G.C.P.	P1dB	IDD(DC)=1100mA typ. ZS=ZL=50ohm	29 ⁺¹ 27 ⁺²	31 ⁺¹ 29.5 ⁺²	-	dBm
Power Gain at 1dB G.C.P.	G1dB	*1: f=3.4 to 4.2 GHz *2: f=4.2 to 5.0 GHz	21 ⁺¹ 21 ⁺²	25 ⁺¹ 25 ⁺²	-	dB
Power-added Efficiency at 1dB G.C.P.	Nadd		-	18 ⁺¹ 12 ⁺²	-	%
Third Order Intermodulation Distortion *3	IM3	*3: df=+10MHz 2-Tone Test Pout=20.0dBm (S.C.L.)	-34 ⁺¹ -32 ⁺²	-39 ⁺¹ -36 ⁺²	-	dBc
Drain Current at 1dB G.C.P.	Iddrf		-	1200 ⁺¹ 1250 ⁺²	1700 ⁺¹ 1700 ⁺²	mA
Input Return Loss at Pin=-20dBm	RLin		-	10	-	dB
Output Return Loss at Pin=-20dBm	RLout		-	10	-	dB

G.C.P. : Gain Compression Point / S.C.L. : Single Carrier Level

ESD	Class 0	=< 250V
-----	---------	---------

Note : Based on JEDEC JESD22-A114C (C=100pF, R=1.5kohm)

CASE STYLE	VU
RoHS COMPLIANCE	YES

ORDERING INFORMATION

Part Number	Order Unit	Packing
EMM5077VU	No Limitation	48 pcs./Tray × 4 Tray = 192 pcs./Packing
EMM5077VUT	500pcs.	500 pcs./Reel × 1 Reel = 500 pcs./Packing



EMM5077VU

C-Band Power Amplifier MMIC

Output Power vs. Frequency

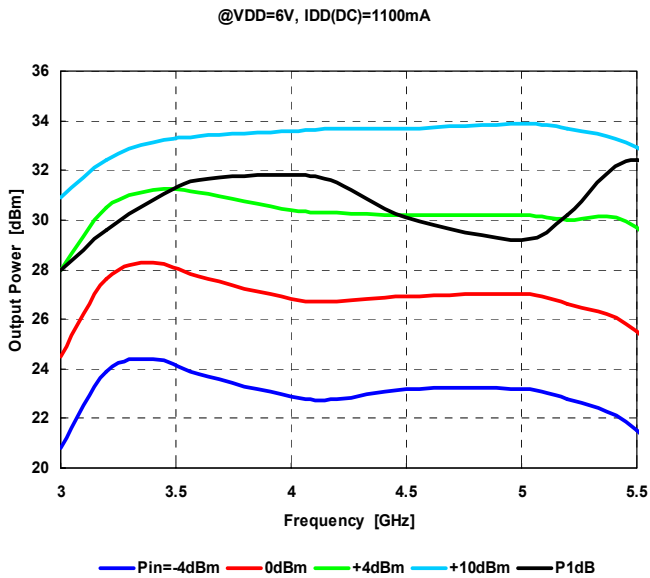

Output Power, Drain Current vs. Input Power

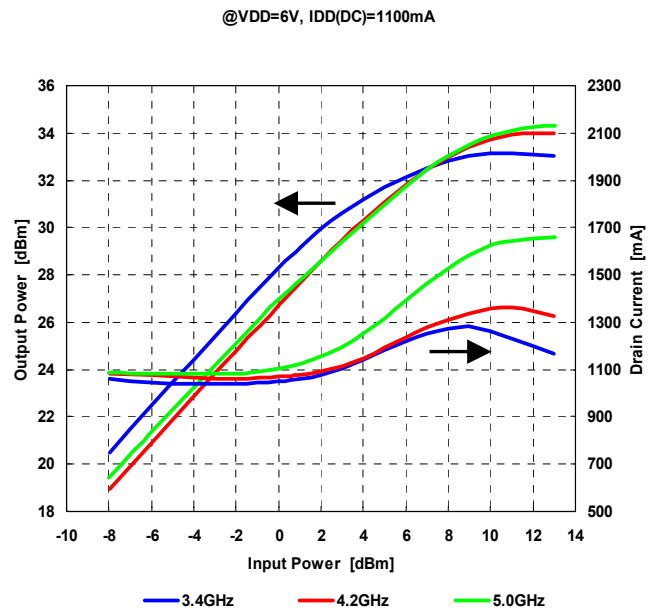

Power Added Efficiency vs. Frequency

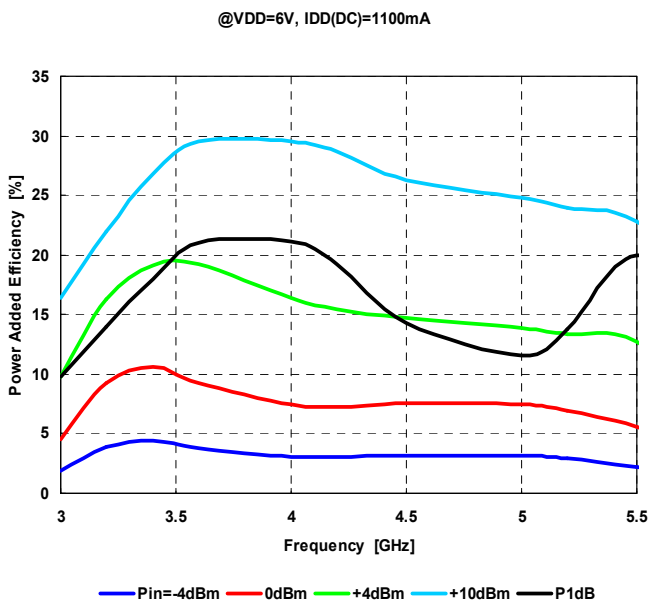



EMM5077VU

C-Band Power Amplifier MMIC

IM3 vs. Frequency

@VDD=6V, IDD(DC)=1100mA, @Po=20dBm S.C.L.

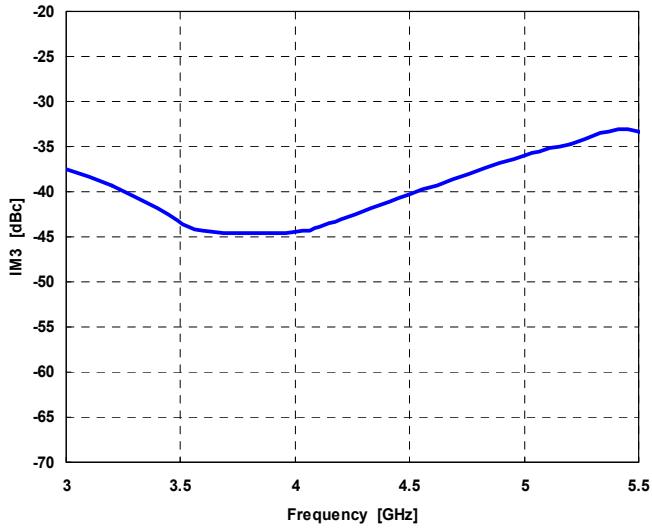

IMD vs. Output Power

@VDD=6V, IDD(DC)=1100mA

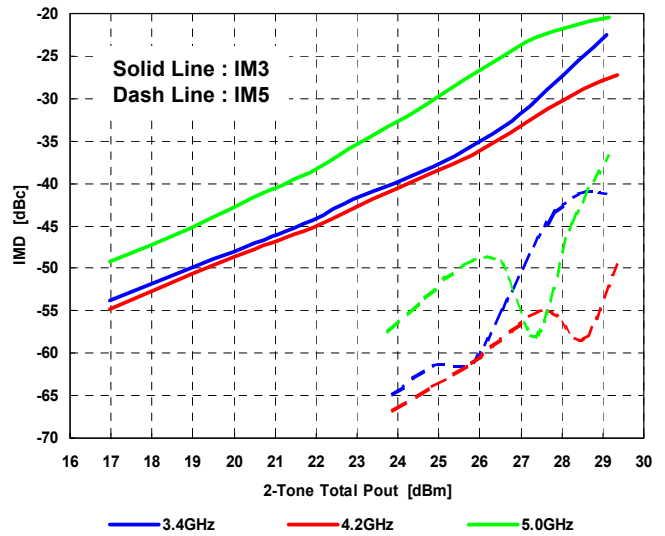

P1dB, G1dB vs. Frequency by Drain Voltage

@IDD(DC)=1100mA

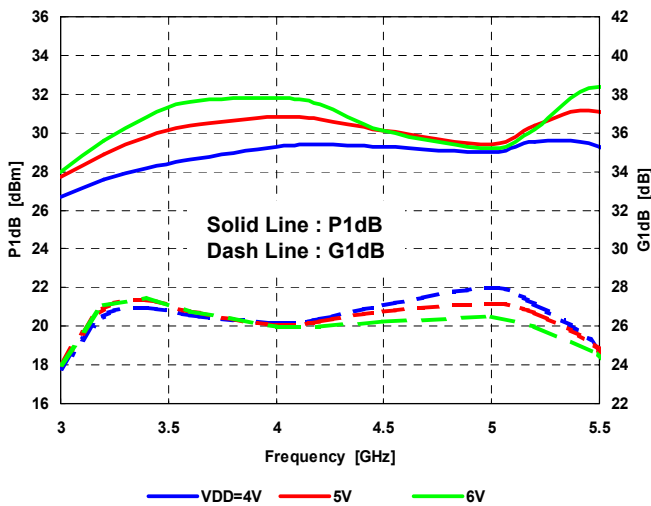

P1dB, G1dB vs. Frequency by Drain Current

@VDD=6V

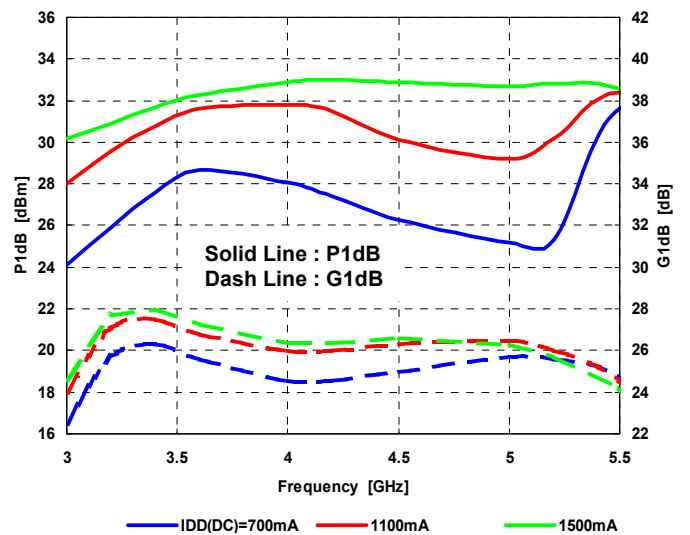



EMM5077VU

C-Band Power Amplifier MMIC

Output Power, Drain Current vs. Input Power by Drain Voltage

@f=3.4GHz, IDD(DC)=1100mA

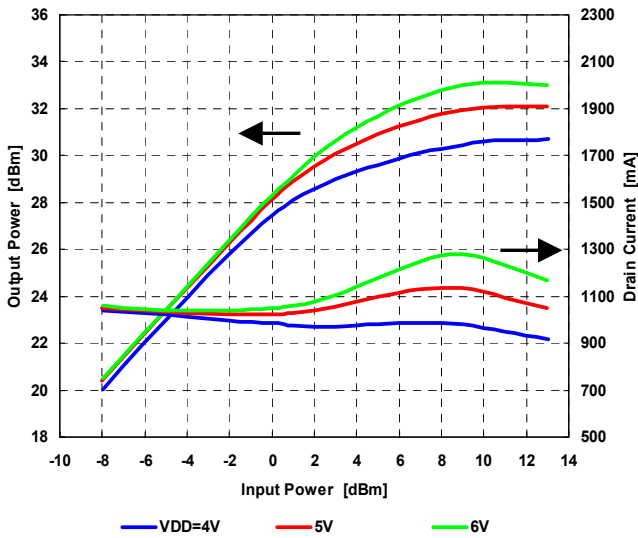

Output Power, Drain Current vs. Input Power by Drain Voltage

@f=4.2GHz, IDD(DC)=1100mA

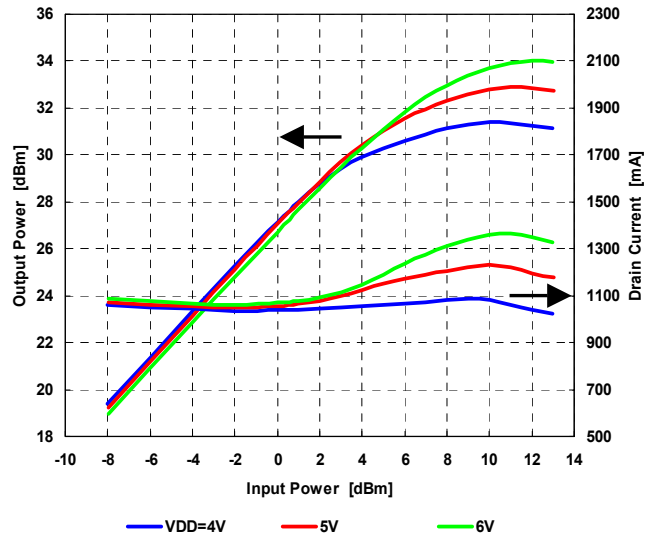

Output Power, Drain Current vs. Input Power by Drain Voltage

@f=5.0GHz, IDD(DC)=1100mA

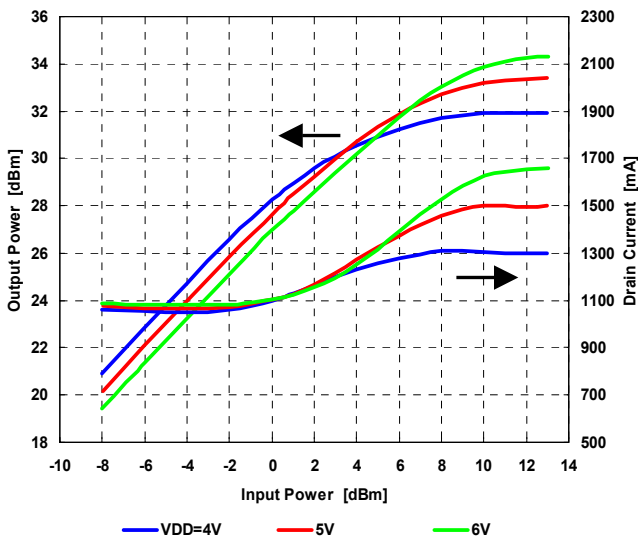



EMM5077VU

C-Band Power Amplifier MMIC

Output Power, Drain Current vs. Input Power by Drain Current

@f=3.4GHz, VDD=6V

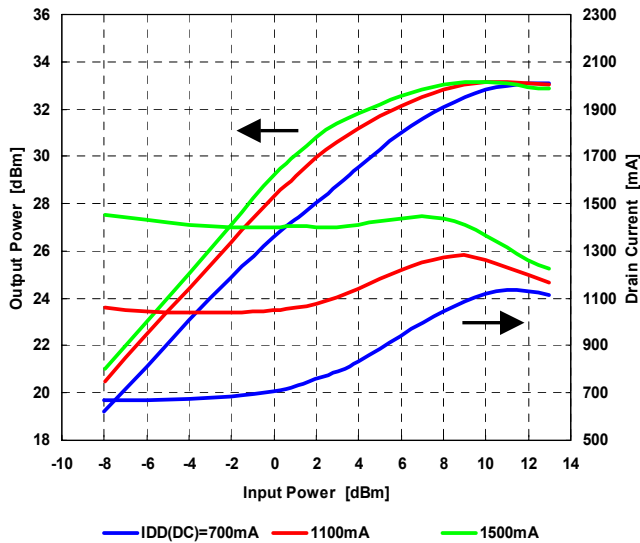

Output Power, Drain Current vs. Input Power by Drain Current

@f=4.2GHz, VDD=6V

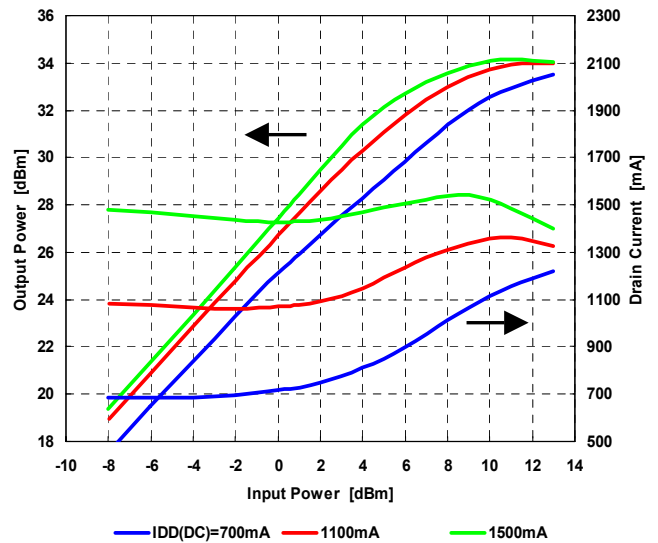

Output Power, Drain Current vs. Input Power by Drain Current

@f=5.0GHz, VDD=6V

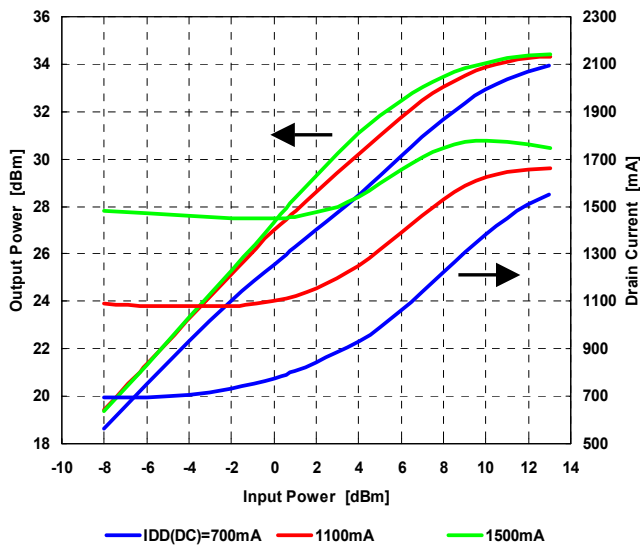



EMM5077VU

C-Band Power Amplifier MMIC

IMD vs. Output Power by Drain Voltage

@f=3.4GHz, IDD(DC)=1100mA

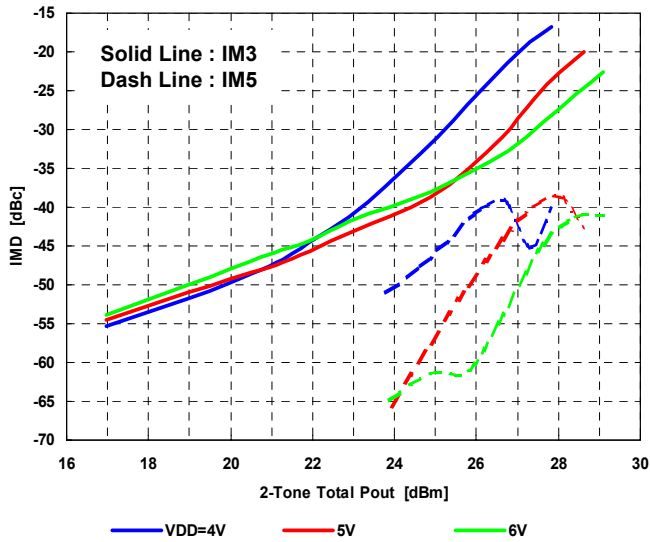

IMD vs. Output Power by Drain Voltage

@f=4.2GHz, IDD(DC)=1100mA

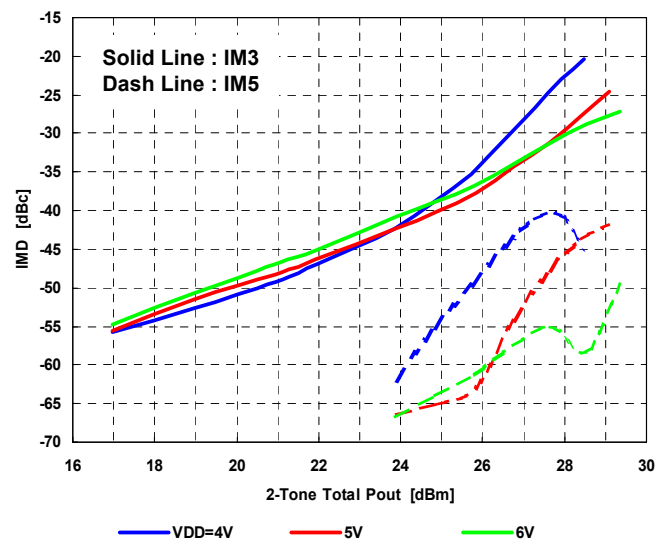

IMD vs. Output Power by Drain Voltage

@f=5.0GHz, IDD(DC)=1100mA

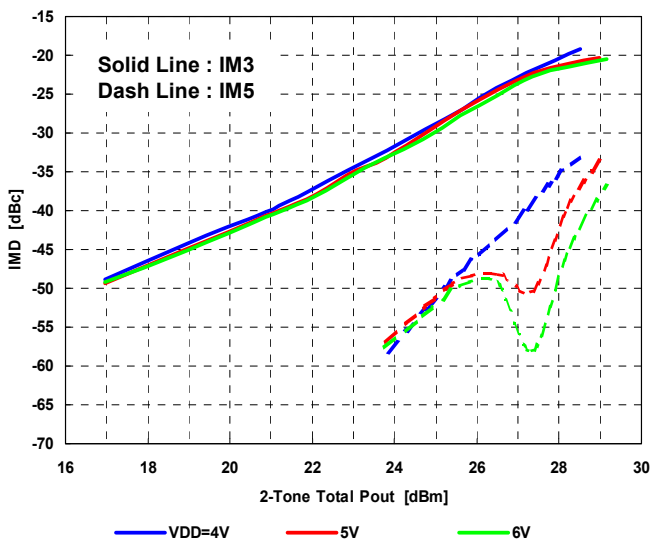



EMM5077VU

C-Band Power Amplifier MMIC

IMD vs. Output Power by Drain Current

@f=3.4GHz, VDD=6V

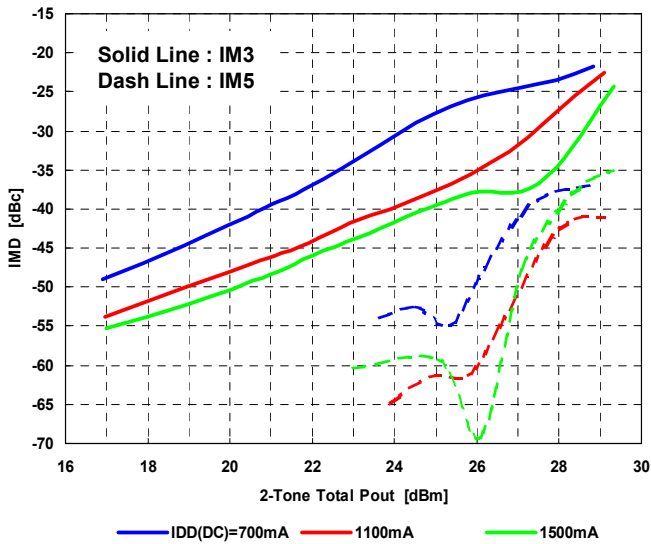

IMD vs. Output Power by Drain Current

@f=4.2GHz, VDD=5V

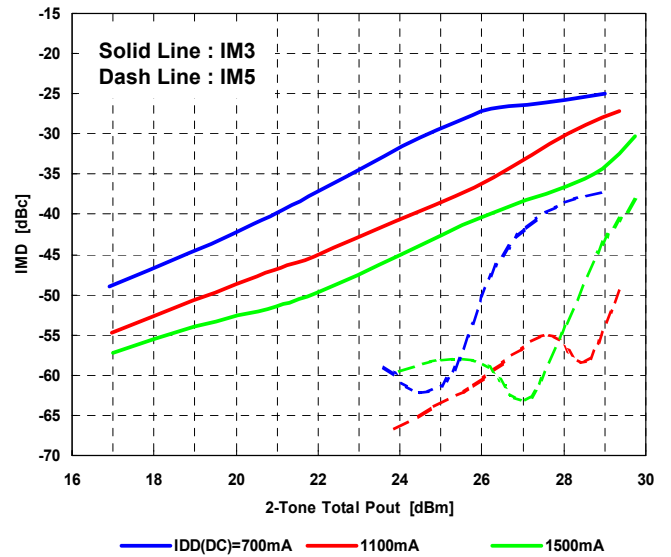

IMD vs. Output Power by Drain Current

@f=5.0GHz, VDD=6V

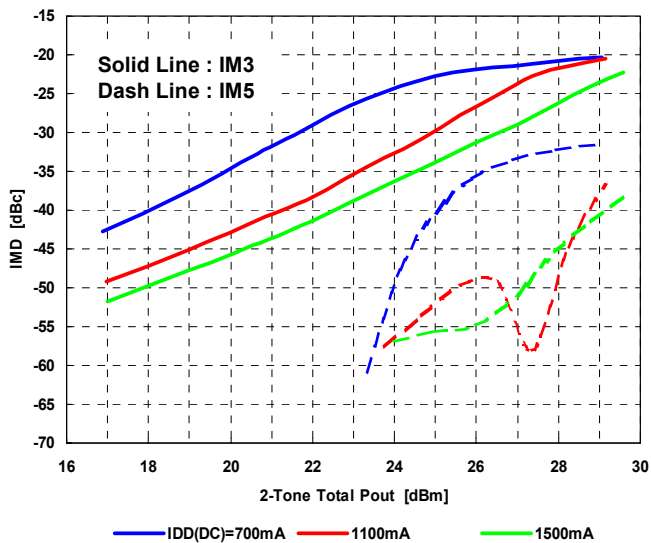

OUTPUT POWER, DRAIN CURRENT vs. INPUT POWER by Temperature

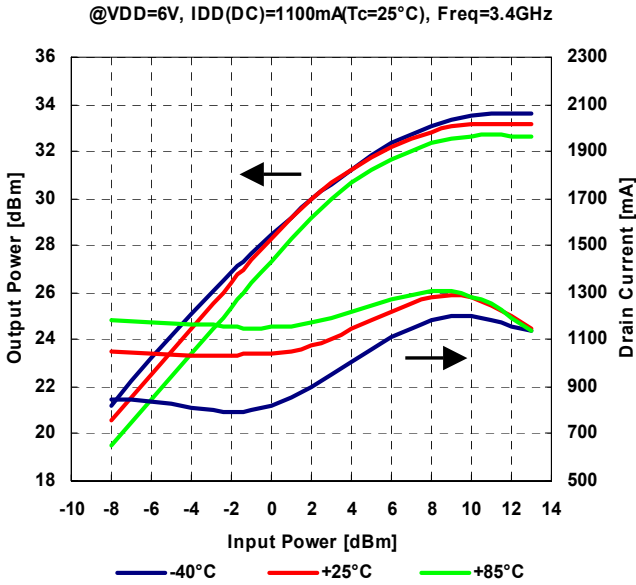

OUTPUT POWER, DRAIN CURRENT vs. INPUT POWER by Temperature

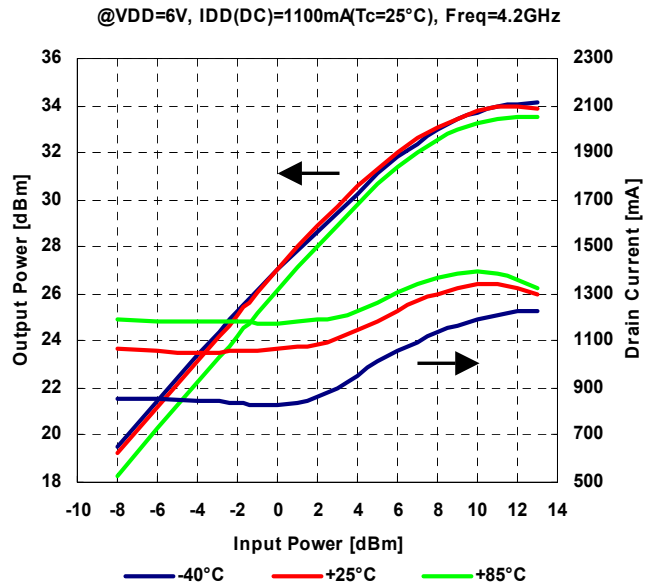

OUTPUT POWER, DRAIN CURRENT vs. INPUT POWER by Temperature

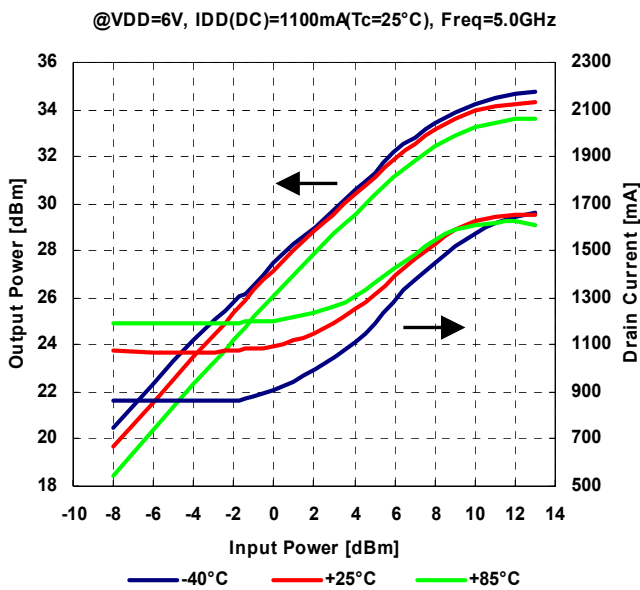

OUTPUT POWER, GAIN vs. TEMPERATURE

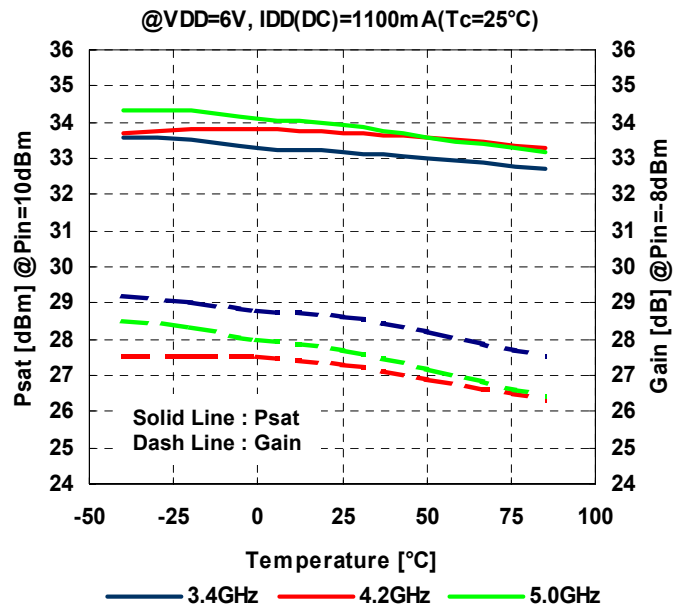



EMM5077VU

C-Band Power Amplifier MMIC

■ S-Parameter

VDD=6V, IDD(DC)=1100mA

Input/Output Return Loss vs. Frequency
VDD=6V, IDD=1100mA

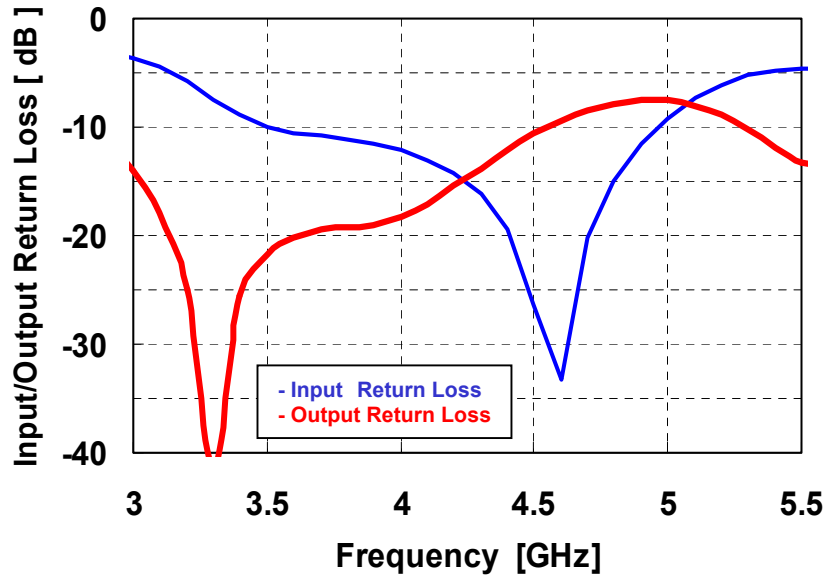

Small Signal Gain vs. Frequency
VDD=6V, IDD=1100mA

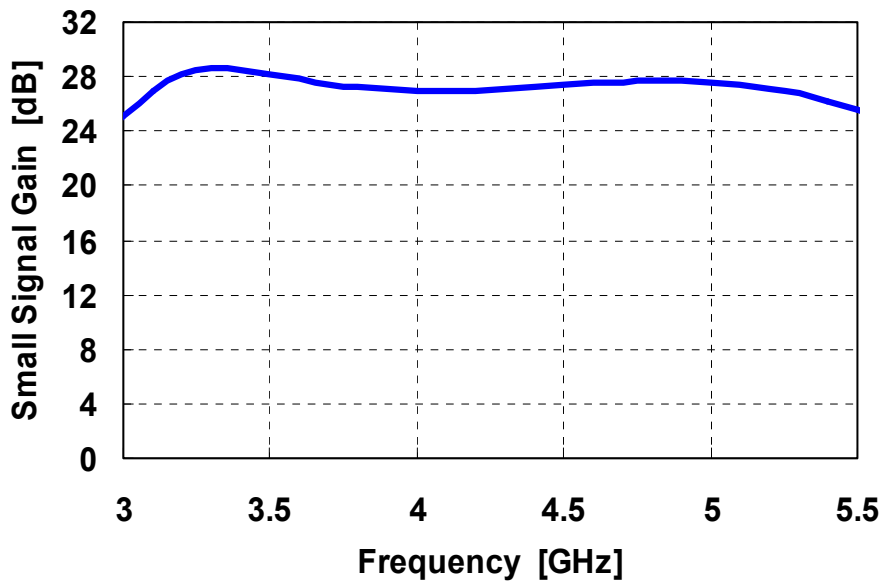



EMM5077VU

C-Band Power Amplifier MMIC

■ S-Parameter

VDD=6V, IDD(DC)=1100mA

Frequency [GHz]	S11		S21		S12		S22	
	MAG	ANG	MAG	ANG	MAG	ANG	MAG	ANG
2.5	0.760	145.2	3.848	-51.7	0.000	107.4	0.516	82.6
2.6	0.751	135.6	5.426	-71.4	0.000	91.3	0.454	63.4
2.7	0.742	125.2	7.544	-92.7	0.000	88.1	0.389	42.3
2.8	0.726	113.5	10.302	-115.9	0.001	69.0	0.326	19.1
2.9	0.703	100.4	13.886	-141.6	0.001	58.3	0.263	-6.6
3.0	0.663	85.8	18.148	-170.0	0.001	36.7	0.198	-35.1
3.1	0.599	70.0	22.390	158.9	0.001	10.8	0.128	-66.2
3.2	0.512	55.4	25.561	126.0	0.002	-28.9	0.057	-99.7
3.3	0.425	44.6	26.874	94.4	0.002	-55.9	0.008	92.0
3.4	0.359	37.3	26.547	65.4	0.002	-94.9	0.053	36.5
3.5	0.318	31.7	25.565	39.3	0.002	-113.9	0.082	16.1
3.6	0.298	25.3	24.584	15.6	0.002	-142.0	0.097	2.0
3.7	0.288	17.6	23.601	-6.2	0.002	-159.8	0.106	-7.5
3.8	0.277	8.9	22.973	-26.9	0.002	-173.2	0.109	-12.2
3.9	0.266	-0.3	22.548	-46.8	0.002	162.7	0.113	-12.3
4.0	0.248	-10.4	22.284	-66.1	0.002	144.4	0.122	-9.7
4.1	0.223	-21.6	22.263	-85.6	0.002	126.7	0.140	-6.7
4.2	0.194	-32.8	22.399	-104.8	0.002	104.1	0.168	-5.4
4.3	0.157	-44.4	22.677	-124.2	0.002	82.4	0.204	-6.8
4.4	0.108	-56.6	23.007	-144.0	0.002	63.7	0.247	-11.0
4.5	0.048	-71.7	23.328	-164.1	0.003	48.3	0.293	-17.1
4.6	0.022	119.7	23.700	175.3	0.003	30.0	0.338	-24.9
4.7	0.098	95.0	23.941	153.9	0.003	8.7	0.378	-33.8
4.8	0.178	80.1	24.144	132.5	0.003	-11.8	0.408	-43.7
4.9	0.263	65.5	24.146	110.5	0.003	-36.6	0.423	-54.0
5.0	0.349	51.2	23.892	87.9	0.003	-59.4	0.420	-64.4
5.1	0.430	37.0	23.432	65.1	0.004	-82.1	0.399	-74.2
5.2	0.496	22.2	22.726	41.8	0.004	-102.4	0.360	-82.5
5.3	0.548	6.5	21.715	18.2	0.004	-124.0	0.309	-88.1
5.4	0.581	-9.7	20.468	-5.5	0.004	-146.2	0.255	-88.7
5.5	0.593	-26.6	18.996	-29.3	0.004	-165.9	0.219	-81.9
5.6	0.582	-44.2	17.341	-53.1	0.003	171.8	0.216	-69.8
5.7	0.550	-62.9	15.617	-76.6	0.003	150.1	0.250	-61.6
5.8	0.500	-83.2	13.809	-100.2	0.003	128.2	0.304	-60.0
5.9	0.442	-105.5	12.011	-123.2	0.002	110.3	0.364	-63.3
6.0	0.387	-130.1	10.348	-145.5	0.002	87.5	0.420	-69.3



EMM5077VU

C-Band Power Amplifier MMIC

ΔT_{ch} vs. DRAIN VOLTAGE
(Reference Data)

IDD(DC)=1100mA

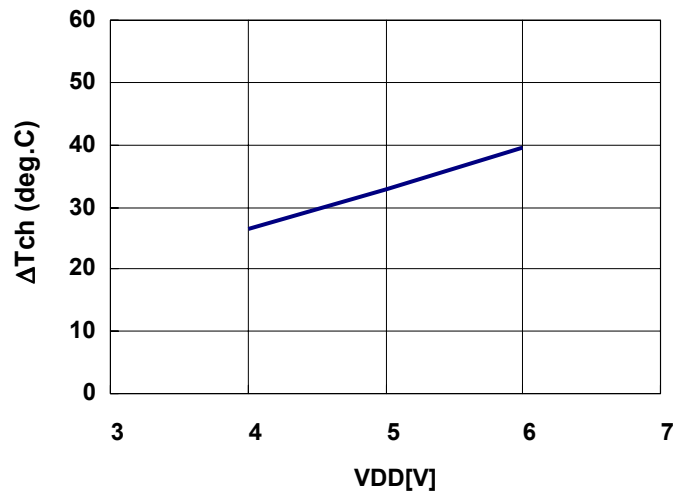

Note : ΔT_{ch} : Temperature Rise from Backside of Package to Channel

MTTF vs. T_{ch}

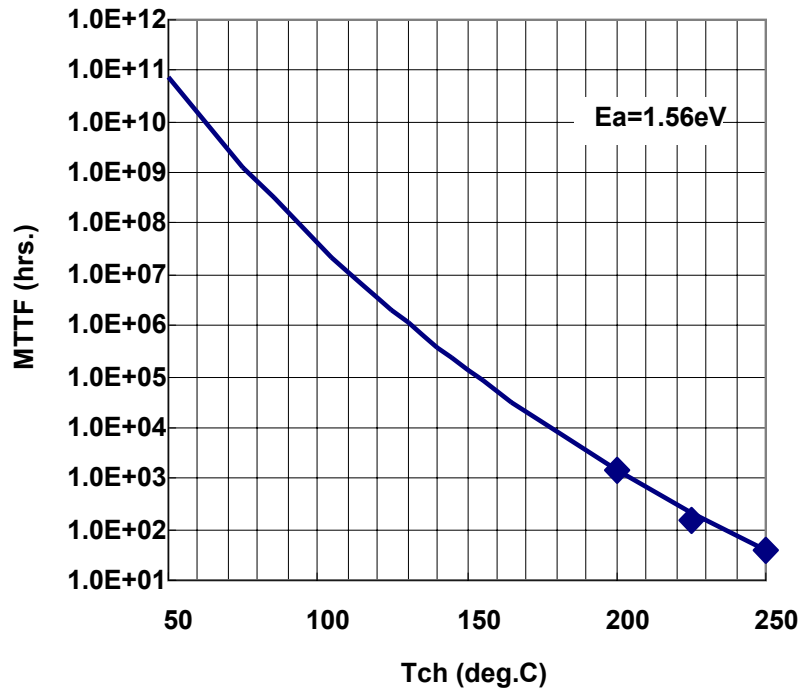

■ Mounting Method of SMD(Surface Mount Devices) for Lead-free solder

Mounting Condition

(1) For soldering, Lead-free solder (Sn-3.0Ag-0.5Cu)*1 or equivalent shall be used.

(*1: The figure displays with weight %. A predominantly tin-rich alloy with 3.0% silver and 0.5% copper.)

(2) A rosin type flux with a chlorine content of 0.2% or less shall be used. The rosin flux with low halogen content is recommended.

(3) When soldering, use one of the following time / temperature methods for acceptable solder joints. Make sure the devices have been properly prepared with flux prior soldering.

* Reflow soldering method (Infrared reflow / Heat circulation reflow / Hot plate reflow):

Limit solder to 3 reflow cycles because resin is used in the modules manufacturing process. Excessive reflow cycles will effect the resin resulting in a potential failure or latent defect. The recommended reflow temperature profile is shown below. The temperature of the reflow profile must be measured at the device body surface.

Reflow temperature profile and condition:

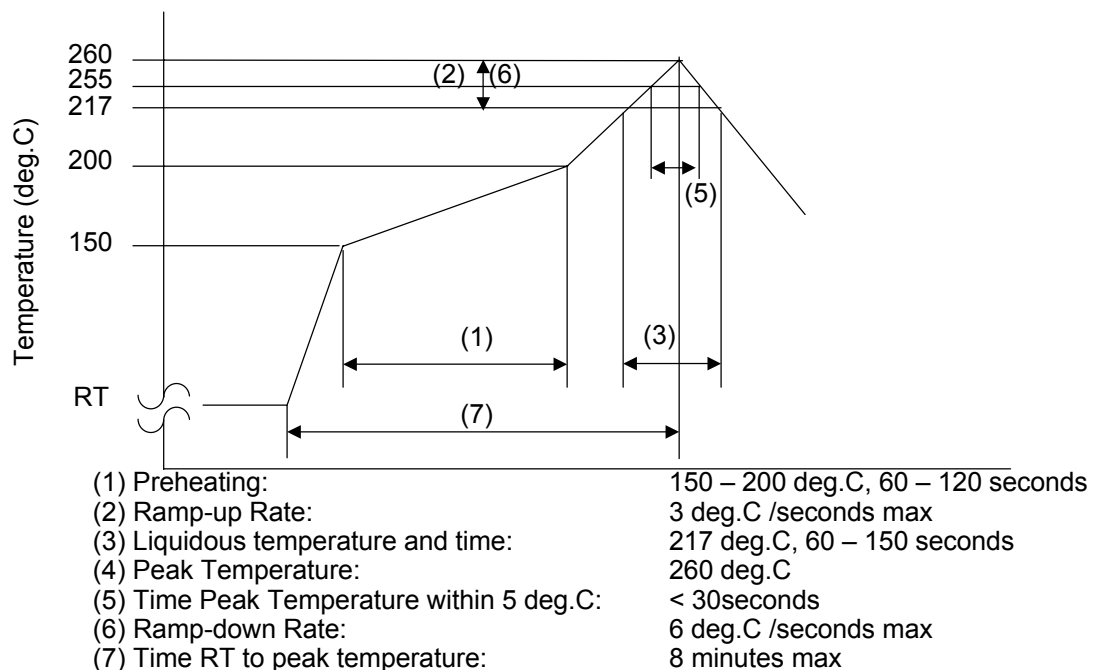

* Measurement point: Center of the package body surface

(4) The above-recommended conditions were confirmed using the manufacture's equipment and materials. However, when soldering these products, the soldering condition should be verified by customer using their equipment and materials.

■ Block diagram

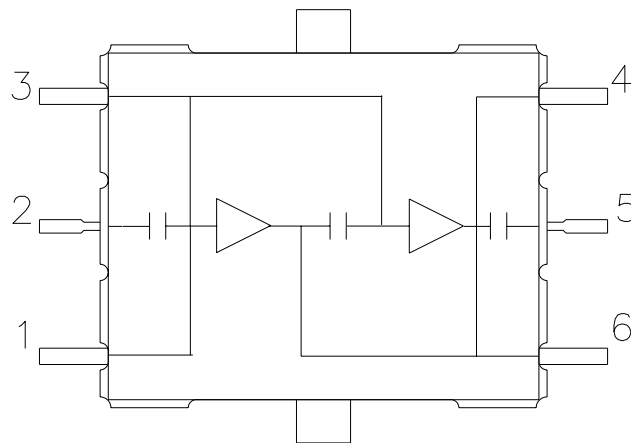

PIN ASSIGNMENT

- 1 : VGG
- 2 : RF in
- 3 : VGG
- 4 : VDD
- 5 : RF out
- 6 : VDD

■ Recommended Bias Circuit

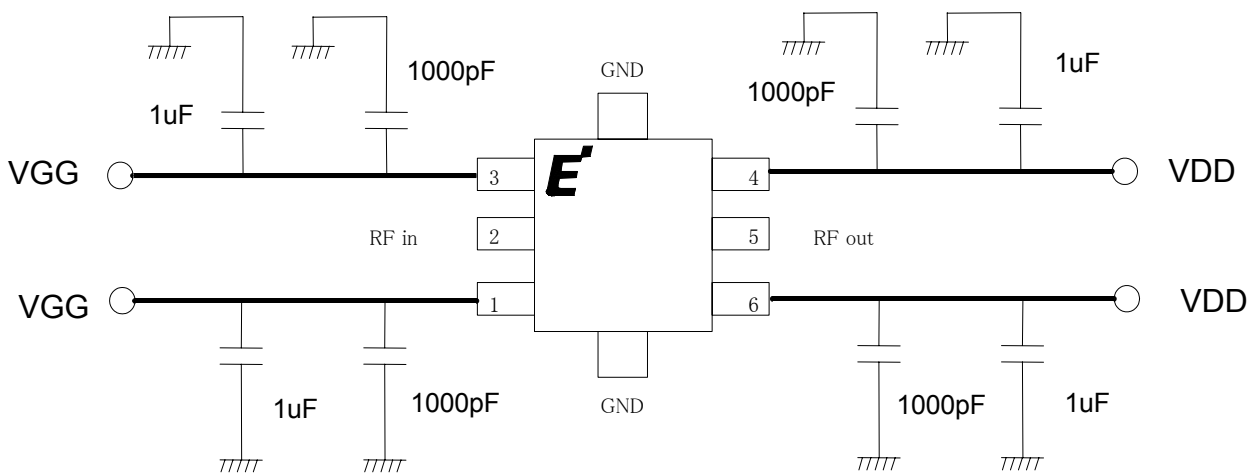

Note 1: The capacitors are recommended on the bias supply line, close to the package, in order to prevent video oscillations which could damage the module.

Note 2: Two pins named VGG are internally connected.

Note 3: Two pins named VDD are internally connected.

■ Package Outline

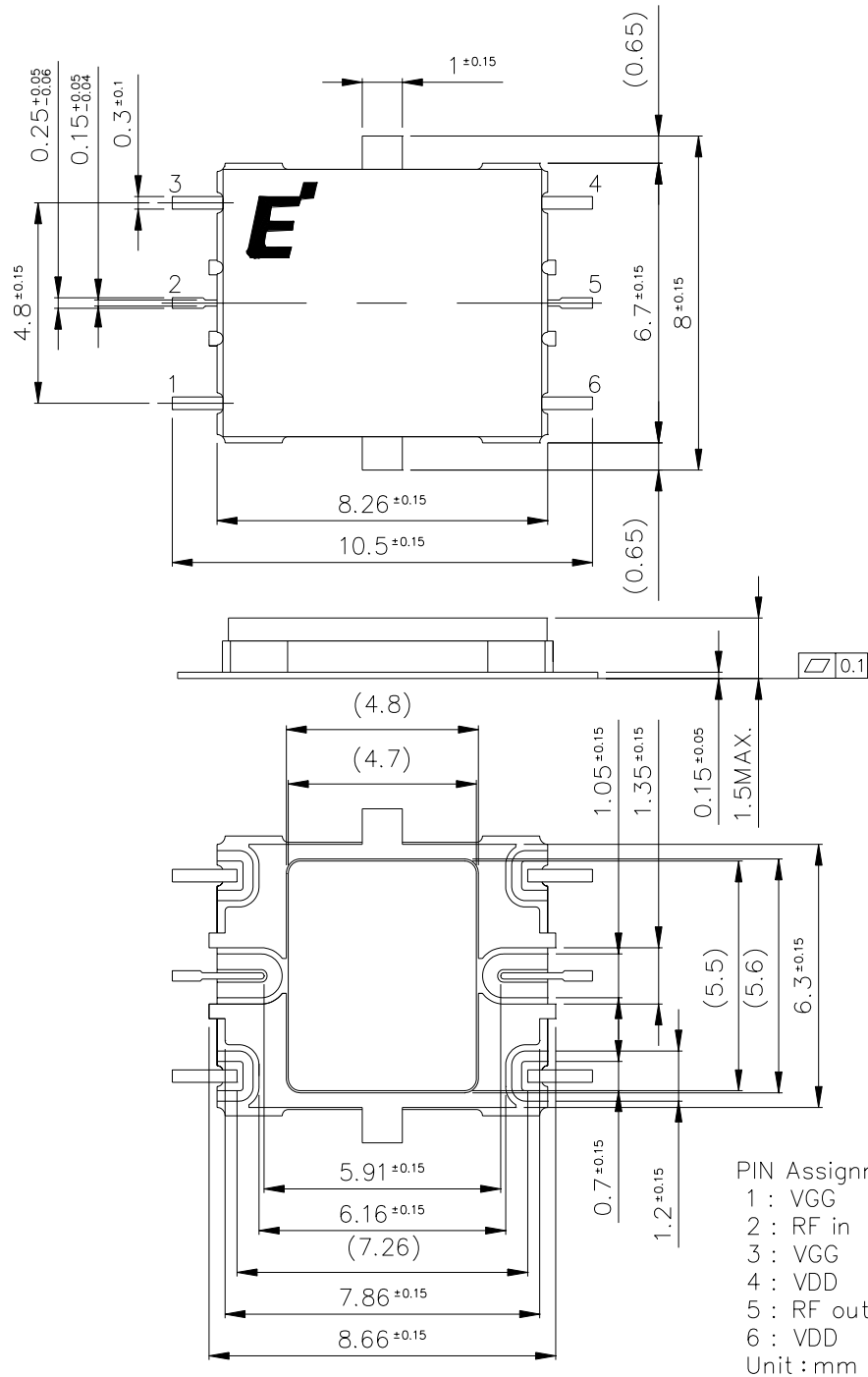

■ PCB Pads and Solder-resist Pattern

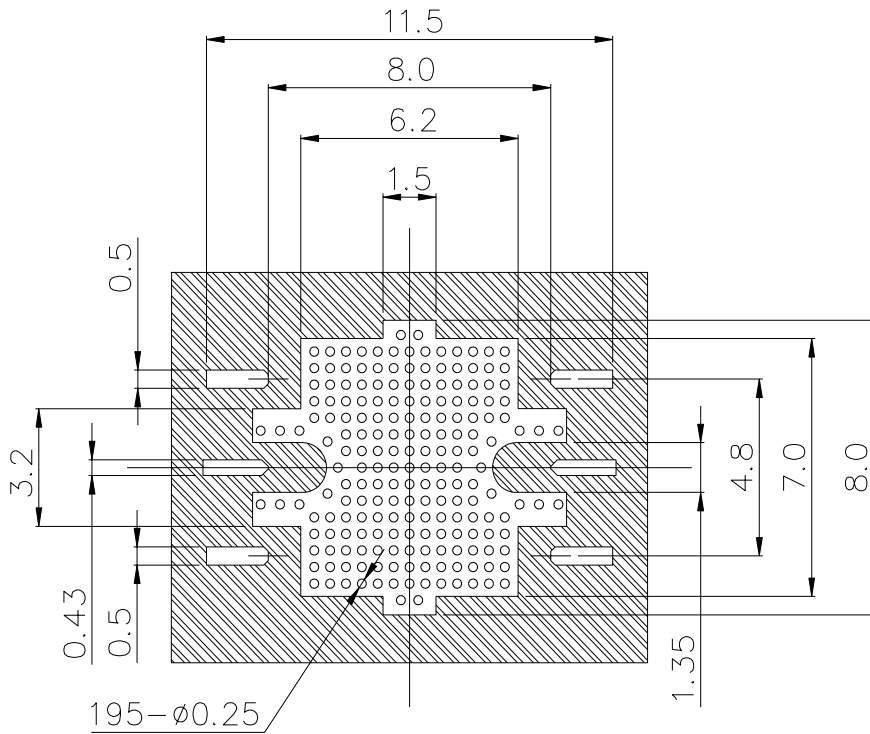

Notes :

1.LAMINATE : Rogers Corporation RO4003, Thickness $t=0.2\text{mm}$, Cu Foil $18\ \mu\text{m}$
 Finish to copper foil ; Ni $0.1\ \mu\text{m}$ min./Au $0.1\pm 0.08\ \mu\text{m}$ (Both side)

2. : Resist

■ 4-inch Tray Packing (Part No. : EMM5077VU)

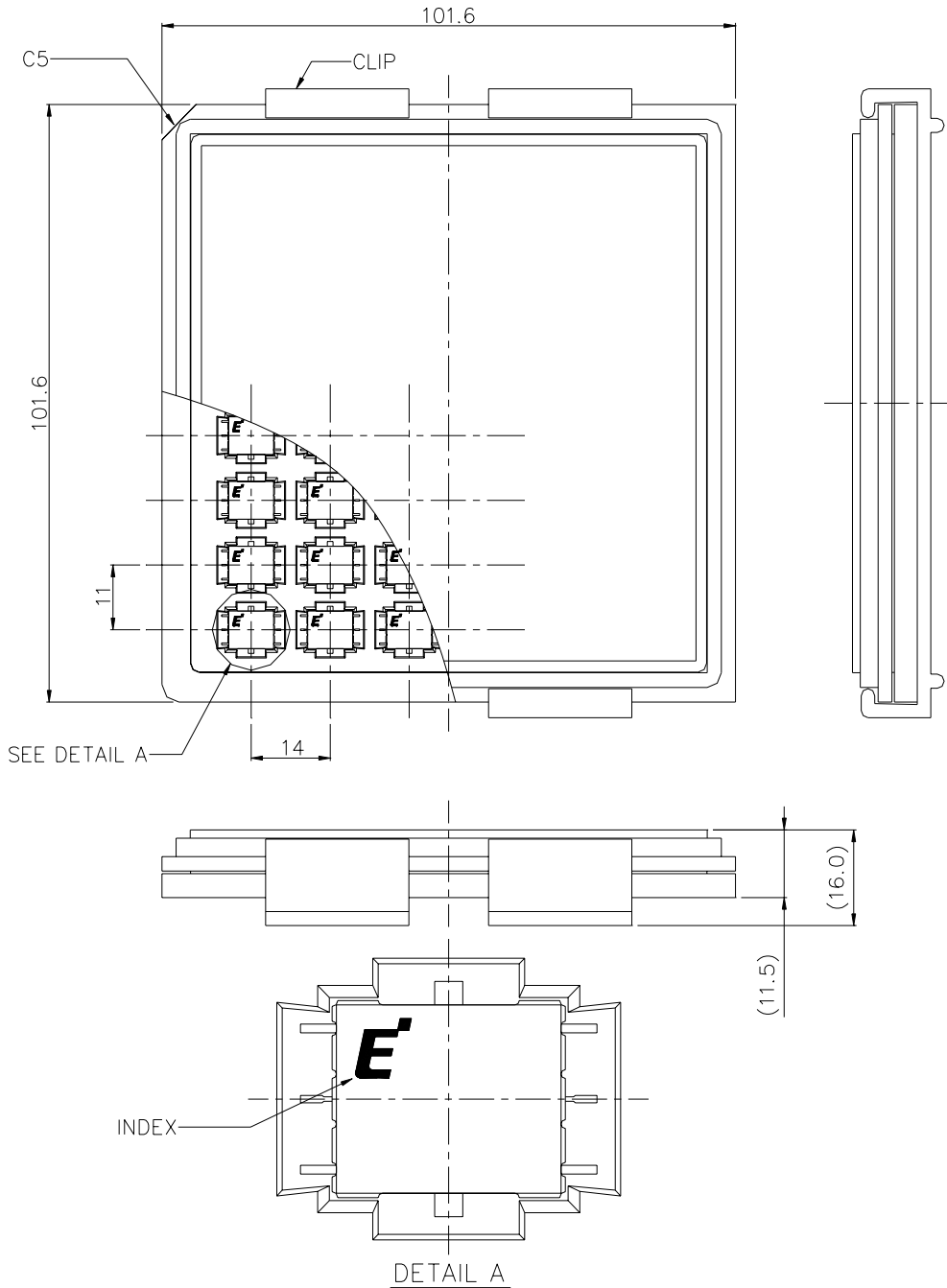

- (1) Maximum Quantity : 48 pcs./Tray
- (2) Tray Material : Conductive PS

■ Tape and Reel Packing (Part No. : EMM5077VUT)

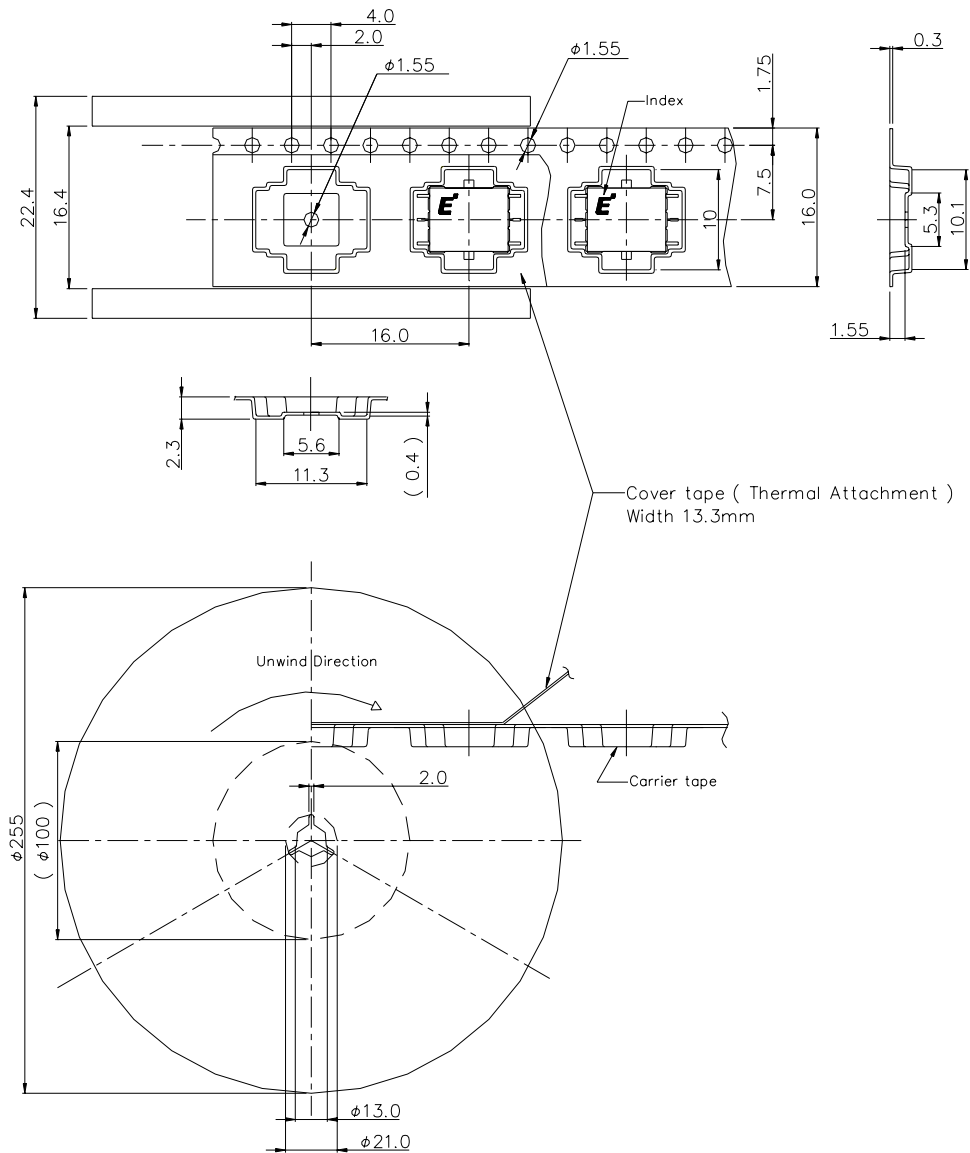

~ 500mm (~ 30~700mm) ~ 500mm (>100mm) ~ 500mm (400~700mm) ~ 1000mm (>500mm)

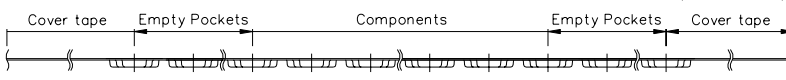

- (1) Quantity 500pcs/tape
- (2) Tape material Conductive A-PET
- (3) Reel material PS



EMM5077VU
C-Band Power Amplifier MMIC

For further information please contact:

<http://global-sei.com/Electro-optic/about/office.html>

CAUTION

This product contains **gallium arsenide (GaAs)** which can be hazardous to the human body and the environment. For safety, observe the following procedures:

- Do not put these products into the mouth.
- Do not alter the form of this product into a gas, powder, or liquid through burning, crushing, or chemical processing as these by-products are dangerous to the human body if inhaled, ingested, or swallowed.
- Observe government laws and company regulations when discarding this product. This product must be discarded in accordance with methods specified by applicable hazardous waste procedures.