

FEATURES

- High Voltage Operation : $V_{DS}=50V$
- High Power : 55.0dBm (typ.) @ P_{sat}
- High Efficiency: 60%(typ.) @ P_{sat}
- Power Gain : 16.0dB(typ.) @ $f=2.6GHz$
- Proven Reliability
- Only For peak stage of Doherty amplifier

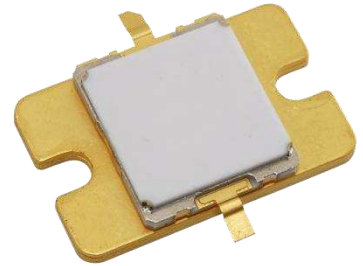

DESCRIPTION

SEDI's GaN-HEMT offers high efficiency, ease of matching, greater consistency and broad bandwidth for high power L-band amplifiers with 50V operation, and gives you higher gain.

This new product is ideally suited for use in 2.6GHz LTE design requirements as it offers high gain, long term reliability and ease of use.

ABSOLUTE MAXIMUM RATINGS (Case Temperature $T_c=25deg.C$)

Item	Symbol	Condition	Rating	Unit
Operating-Voltage	V_{DS}		55	V
Drain-Source Voltage	V_{DS}	$V_{GS}=-8V$	160	V
Gate-Source Voltage	V_{GS}		-15	V
Total Power Dissipation	P_t	$T_c=25deg.C$	141	W
Storage Temperature	T_{stg}		-65 to +175	deg.C
Channel Temperature	T_{ch}		250	deg.C

RECOMMENDED OPERATING CONDITION

Item	Symbol	Condition	Limit	Unit
DC Input Voltage	V_{DS}		≤ 55	V
Forward Gate Current	I_{GF}	$R_G=10\text{ ohm}$	≤ 358	mA
Reverse Gate Current	I_{GR}	$R_G=10\text{ ohm}$	≥ -11.7	mA
Channel Temperature	T_{ch}		≤ 180	deg.C
Average Output Power	$P_{ave.}$		≤ 50	dBm

ELECTRICAL CHARACTERISTICS (Case Temperature $T_c=25deg.C$)

Item	Symbol	Condition	Limit			Unit
			Min.	Typ.	Max.	
Pinch-Off Voltage	V_p	$V_{DS}=50V\ I_{DS}=81.2mA$	-1.0	-1.5	-2.0	V
Saturated Power	$P_{sat} *1$	$V_{DS}=50V$	54.2	55.0	-	dBm
Power Gain	$G_p *2$	$I_{DS}(DC)=10mA$ $f=2.6GHz$	15.0	16.0	-	dB
Thermal Resistance	R_{th}	Channel to Case at 105W P_{DC}	-	1.2	1.6	deg.C/W

*1 : $P_{in}=42dBm$ 10%-duty RF pulse (DC supply constant)

*2 : $P_{out}=51.5dBm$ 10%-duty RF pulse (DC supply constant)

RoHS COMPLIANCE	Yes
-----------------	-----

I2D Package Outline Metal-Ceramic Hermetic Package

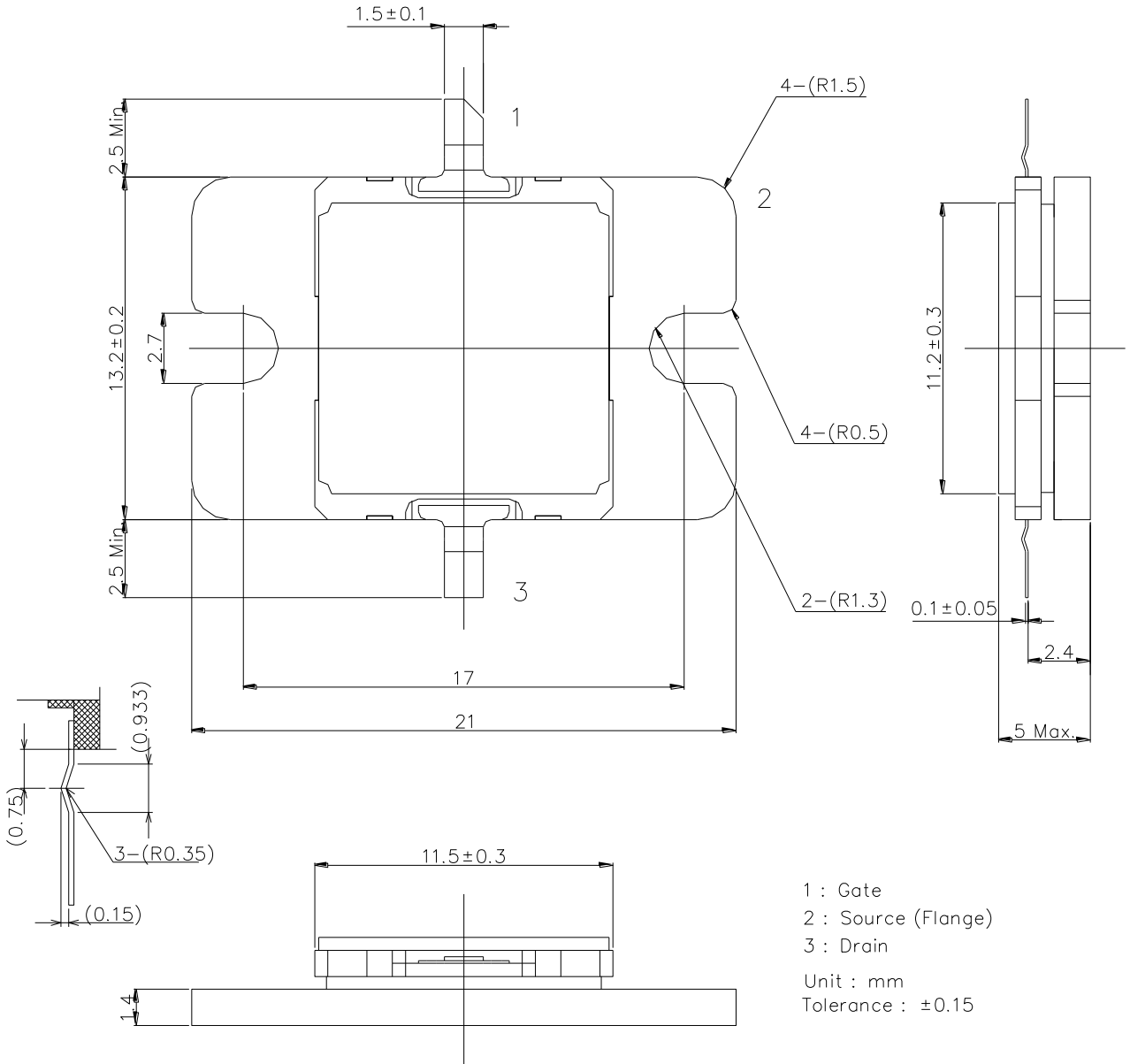



SGN26C320I2D

High Voltage - High Power GaN-HEMT

For further information please contact:

<http://global-sei.com/Electro-optic/about/office.html>