

FEATURES

- High Voltage Operation : $V_{DS}=50V$
- High Power : 53.0dBm (typ.) @ P_{sat}
- High Efficiency: 62%(typ.) @ P_{sat}
- Power Gain : 16dB(typ.) @ $f=2.6GHz$
- Proven Reliability

DESCRIPTION

SEI's GaN-HEMT offers high efficiency, ease of matching, greater consistency and broad bandwidth for high power L-band amplifiers with 50V operation, and gives you higher gain.

This new product is ideally suited for use from 2.3GHz to 2.7GHz LTE design requirements as it offers high gain, long term reliability and ease of use.



ABSOLUTE MAXIMUM RATINGS (Case Temperature $T_c=25deg.C$)

Item	Symbol	Condition	Rating	Unit
Operating-Voltage	V_{DS}		55	V
Drain-Source Voltage	V_{DS}	$V_{GS}=-8V$	160	V
Gate-Source Voltage	V_{GS}		-15	V
Total Power Dissipation	P_t		173	W
Storage Temperature	T_{stg}		-65 to +175	deg.C
Channel Temperature	T_{ch}		250	deg.C

RECOMMENDED OPERATING CONDITION

Item	Symbol	Condition	Limit	Unit
DC Input Voltage	V_{DS}		≤ 55	V
Forward Gate Current	I_{GF}	$R_G=5\text{ ohm}$	≤ 204	mA
Reverse Gate Current	I_{GR}	$R_G=5\text{ ohm}$	≥ -7.8	mA
Channel Temperature	T_{ch}		≤ 180	deg.C
Average Output Power	$P_{ave.}$		≤ 50.5	dBm

ELECTRICAL CHARACTERISTICS (Case Temperature $T_c=25deg.C$)

Item	Symbol	Condition	Limit			Unit
			Min.	Typ.	Max.	
Pinch-Off Voltage	V_p	$V_{DS}=50V\ I_{DS}=54.4mA$	-1.0	-1.5	-2.0	V
Saturated Power	$P_{sat} *1$	$V_{DS}=50V$	52.0	53.0	-	dBm
Drain Efficiency	$\eta_d *2$	$I_{DS}(DC)=750mA$	25	30	-	%
Power Gain	$G_p *2$	$f=2.60GHz$	15.0	16.0	-	dB
Thermal Resistance	R_{th}	Channel to Case at 105W P_{DC}	-	1.1	1.3	deg.C/W

*1 : 10%-duty RF pulse (DC supply constant)

*2 : $P_{out} = 45.0dBm$, CW modulation Signal (W-CDMA)

RoHS COMPLIANCE	Yes
------------------------	------------

RF characteristics @ f=2.6GHz fine tuned

Output Power vs. Frequency
 $V_{DS}=50V$ $I_{DS(DC)}=750mA$

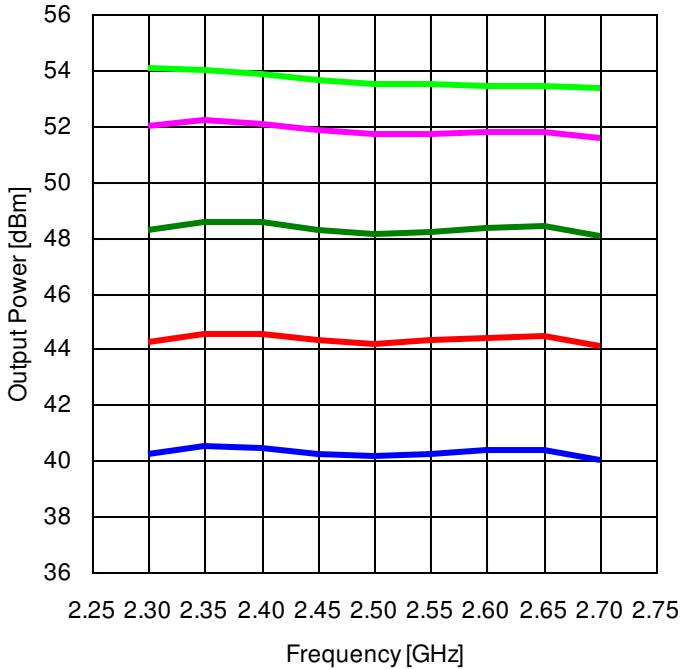

Output Power and Drain Efficiency vs. Input Power
 $V_{DS}=50V$ $I_{DS(DC)}=750mA$ $f=2.6GHz$

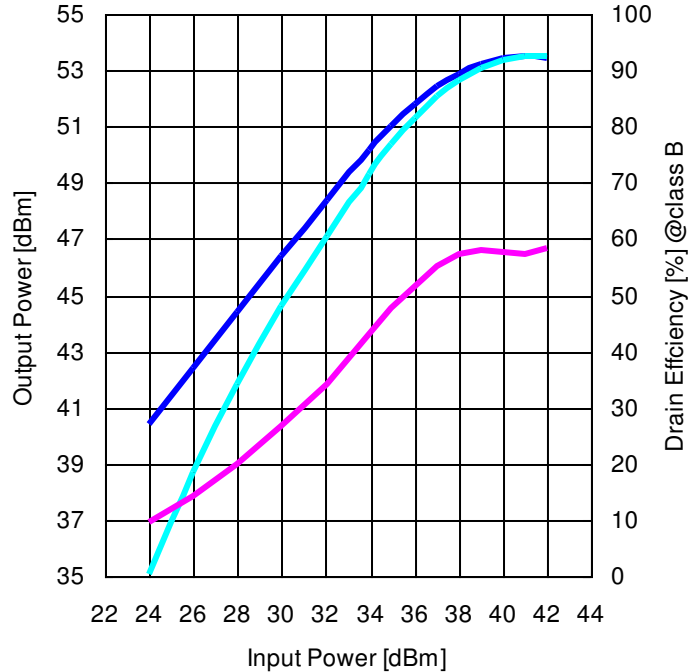

— Pin=24dBm — Pin=28dBm — Pin=32dBm
— Pin=36dBm — Pin=40dBm

— Pout (class AB) — Pout (class B) — Nd (class B)

Pulse Signal (10%-duty, DC : constant)

Test Fixture

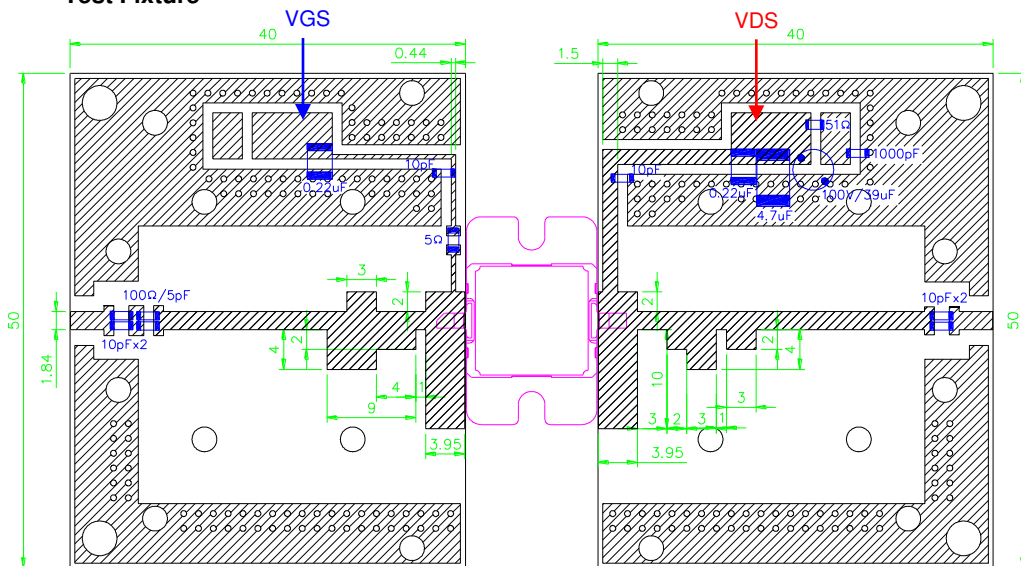

$h=0.8mm$ $\epsilon r=3.5$
 $Cu=18\mu m$ Unit:mm

MTTF Calculation - Estimated MTTF -

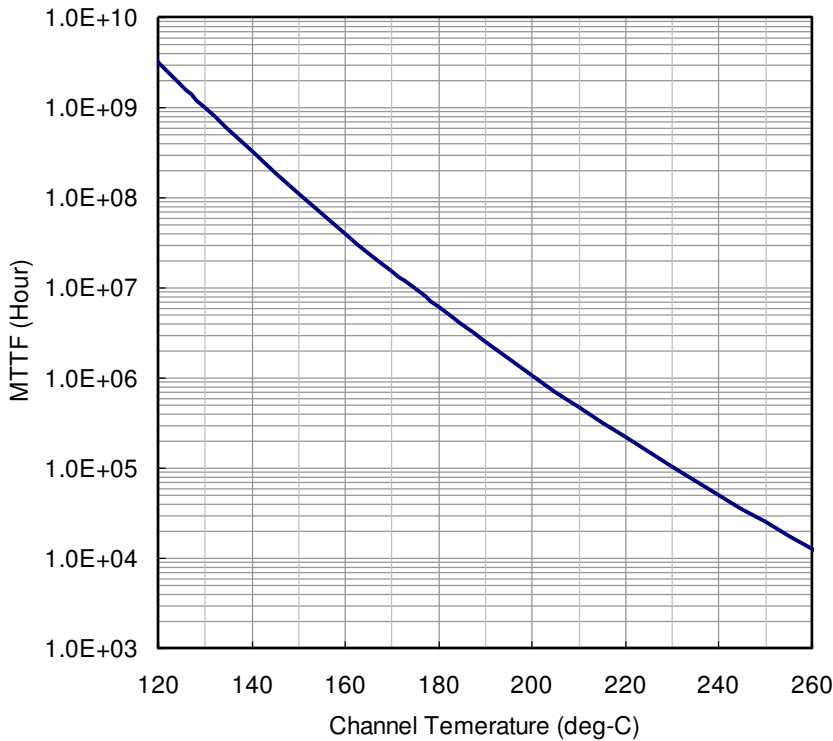

Ea=1.6eV
Confidence Level=90%

Channel Temp (deg-C)	MTTF (Hours)
160	4.05 x 10 ⁷
180	6.07 x 10 ⁶
200	1.07 x 10 ⁶

$$AF = \exp\left[-\frac{Ea}{k}\left(\frac{1}{T_{stress}} - \frac{1}{T_{use}}\right)\right]$$

$$MTTF_{use} = MTTF_{stress} * AF$$

Where;

AF: acceleration factor

Ea: activation energy (1.6 eV)

k: Boltzman's constant (8.62 x 10⁻⁵ eV/K)

T_{stress}: stress temperature (K)

T_{use}: use temperature (K)

ESD Characteristics

Test Methodology	Class
Human Body Model (per JESD22-A114)	1B
Machine Model (per JEIA/ESD22-A115)	A

S-Parameters @V_{DS}=50V, I_{DS(DC)}=750mA, f=0.5 to 4.5 GHz
 Z_I = Z_s = 50 ohm Marker : 2.6GHz

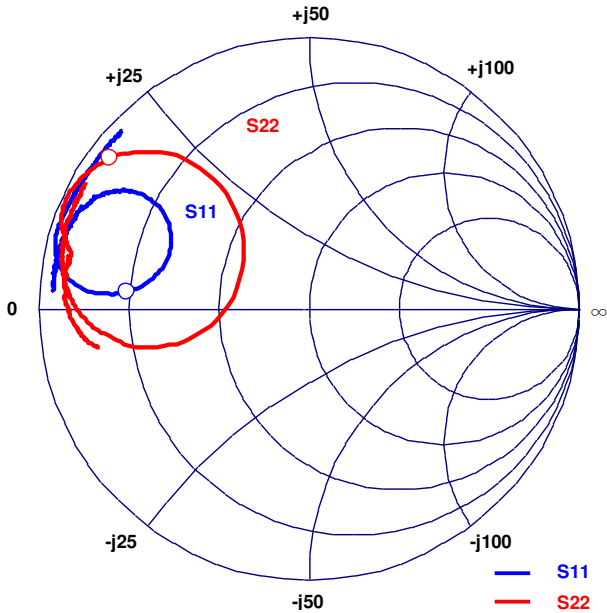

Freq. GHz	S11		S21		S12		S22	
	MAG	ANG	MAG	ANG	MAG	ANG	MAG	ANG
0.50	0.94	176.36	3.74	33.12	0.002	-14.40	0.79	-169.29
0.60	0.95	174.65	2.94	25.73	0.002	-18.06	0.82	-171.18
0.70	0.95	172.68	2.38	18.23	0.002	-14.91	0.85	-173.63
0.80	0.95	171.25	2.00	12.90	0.002	-1.98	0.86	-175.45
0.90	0.95	170.02	1.75	7.10	0.002	0.34	0.88	-177.52
1.00	0.95	168.47	1.55	1.56	0.002	16.92	0.89	-179.28
1.10	0.95	166.76	1.42	-2.99	0.002	15.67	0.90	179.25
1.20	0.95	164.90	1.33	-8.44	0.002	17.17	0.90	177.42
1.30	0.94	163.33	1.26	-13.24	0.003	27.45	0.90	175.97
1.40	0.94	161.71	1.25	-17.85	0.004	28.22	0.91	174.59
1.50	0.93	159.56	1.24	-23.64	0.004	29.70	0.91	173.22
1.60	0.93	158.11	1.28	-28.61	0.005	25.13	0.91	172.03
1.70	0.92	156.08	1.35	-35.15	0.005	23.13	0.91	170.51
1.80	0.90	153.76	1.45	-41.87	0.006	16.75	0.90	169.28
1.90	0.87	151.21	1.62	-50.11	0.008	12.01	0.90	168.32
2.00	0.83	148.75	1.84	-59.95	0.009	4.41	0.90	167.19
2.10	0.77	146.51	2.16	-72.17	0.011	-7.46	0.91	166.60
2.20	0.69	145.89	2.57	-88.03	0.013	-22.04	0.92	165.51
2.30	0.60	148.89	2.98	-107.63	0.015	-41.26	0.95	163.41
2.40	0.55	158.94	3.38	-130.44	0.018	-64.33	0.98	159.36
2.50	0.59	169.66	3.59	-155.27	0.019	-89.80	0.98	152.35
2.60	0.68	174.90	3.77	179.82	0.021	-115.44	0.92	143.04
2.70	0.77	175.98	3.87	150.86	0.022	-147.29	0.74	130.90
2.80	0.88	173.79	3.64	117.05	0.021	178.84	0.41	128.16
2.90	0.95	168.72	2.85	82.56	0.016	142.42	0.32	-176.77
3.00	0.97	164.02	1.93	55.07	0.012	115.59	0.58	-165.78
3.10	0.97	160.72	1.26	36.77	0.008	103.14	0.74	-171.87
3.20	0.97	158.27	0.88	23.93	0.006	90.63	0.83	-177.24
3.30	0.96	156.36	0.62	14.32	0.005	88.32	0.88	178.01
3.40	0.96	154.58	0.46	7.35	0.004	87.50	0.90	174.68
3.50	0.96	153.05	0.36	0.88	0.004	94.57	0.92	171.39
3.60	0.96	151.47	0.28	-3.01	0.004	95.58	0.93	168.90
3.70	0.96	149.91	0.23	-7.36	0.004	93.46	0.94	166.70
3.80	0.96	148.53	0.19	-11.66	0.005	93.79	0.94	164.42
3.90	0.95	147.08	0.16	-14.10	0.005	91.61	0.94	162.67
4.00	0.96	145.63	0.14	-16.63	0.005	87.83	0.95	160.43
4.10	0.95	143.83	0.12	-17.83	0.006	87.77	0.94	158.47
4.20	0.95	142.21	0.11	-19.89	0.006	80.31	0.95	156.69
4.30	0.95	140.48	0.10	-23.04	0.006	80.68	0.95	154.60
4.40	0.95	138.47	0.09	-24.19	0.006	77.45	0.94	152.82
4.50	0.95	136.54	0.09	-30.20	0.007	68.55	0.95	150.73

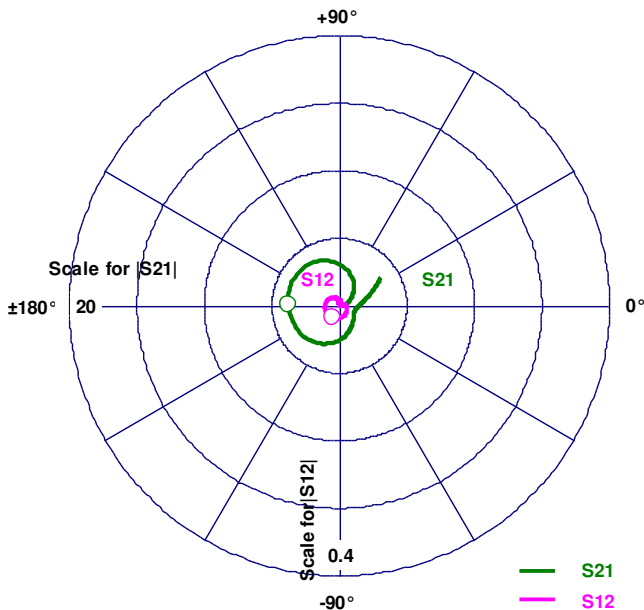

I2D Package Outline Metal-Ceramic Hermetic Package

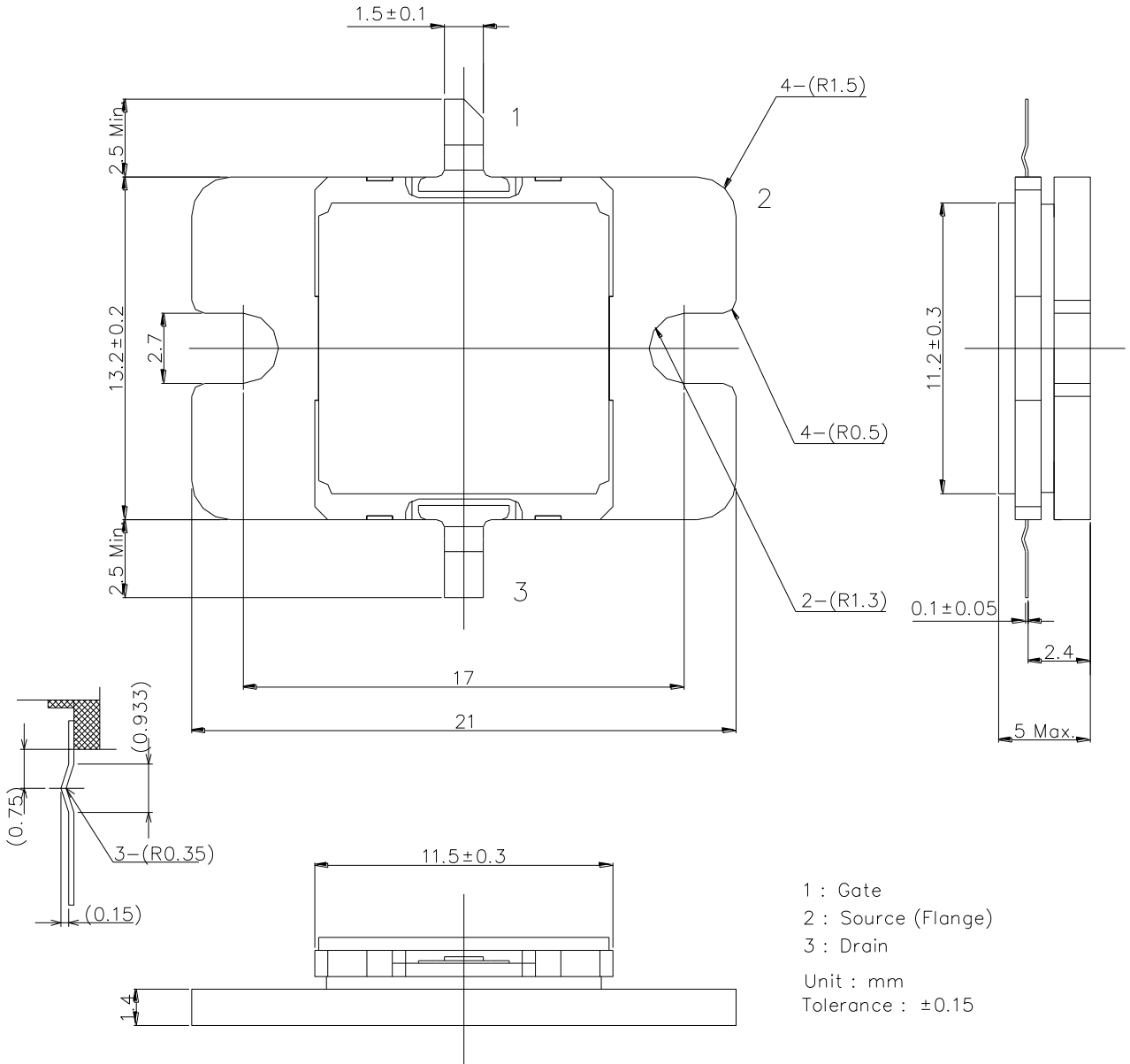



EGN26C210I2D

High Voltage - High Power GaN-HEMT

For further information please contact:

<http://global-sei.com/Electro-optic/about/office.html>