

FEATURES

- High Voltage Operation : $V_{DS}=50V$
- High Power : 55.0dBm (typ.) @ P_{sat}
- High Efficiency: 65%(typ.) @ P_{sat}
- Power Gain : 18dB(typ.) @ $f=2.14GHz$
- Proven Reliability

DESCRIPTION

SEI's GaN-HEMT offers high efficiency, ease of matching, greater consistency and broad bandwidth for high power L-band amplifiers with 50V operation, and gives you higher gain.

This new product is ideally suited for use in 2.14GHz W-CDMA & LTE design requirements as it offers high gain, long term reliability and ease of use.

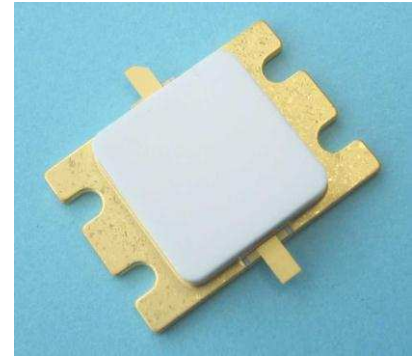

ABSOLUTE MAXIMUM RATINGS (Case Temperature $T_c=25deg.C$)

Item	Symbol	Condition	Rating	Unit
Operating-Voltage	V_{DS}		55	V
Drain-Source Voltage	V_{DS}	$V_{GS}=-8V$	160	V
Gate-Source Voltage	V_{GS}		-15	V
Total Power Dissipation	P_t		250	W
Storage Temperature	T_{stg}		-65 to +175	deg.C
Channel Temperature	T_{ch}		250	deg.C

RECOMMENDED OPERATING CONDITION

Item	Symbol	Condition	Limit	Unit
DC Input Voltage	V_{DS}		≤ 55	V
Forward Gate Current	I_{GF}	$R_G=50\Omega$	≤ 306	mA
Reverse Gate Current	I_{GR}	$R_G=50\Omega$	≥ -11.7	mA
Channel Temperature	T_{ch}		≤ 180	deg.C
Average Output Power	P_{ave}		≤ 52.0	dBm

ELECTRICAL CHARACTERISTICS (Case Temperature $T_c=25deg.C$)

Item	Symbol	Condition	Limit			Unit
			Min.	Typ.	Max.	
Pinch-Off Voltage	V_p	$V_{DS}=50V$ $I_{DS}=54.4mA$	-1.0	-1.5	-2.0	V
Saturated Power	$P_{sat} *1$	$V_{DS}=50V$	54.2	55.0	-	dBm
Drain Efficiency	$\eta_d *2$	$I_{DS}(DC)=1.1A$	28.0	31.0	-	%
Power Gain	$G_p *2$		17.0	18.0	-	dB
3 rd Order Inter-modulation Distortion	$IM3 *2$		-28	-32	-	dBc
Thermal Resistance	R_{th}	Channel to Case at 157.5W P_{DC}	-	0.8	0.9	deg.C/W

*1 : 10%-duty RF pulse (DC supply constant), $f=2.14GHz$

*2 : $P_{out} = 47dBm$, $f_0=2.135GHz$, $f_1=2.145GHz$, W-CDMA(3GPP3.4 12-00) BS-1 64ch 47.5% clipping modulation (Peak/Avg.=8.5dB@0.01% Probability on CCDF).

RoHS COMPLIANCE	Yes
------------------------	------------

RF characteristics @f=2.14GHz fine tuned

Output Power vs. Frequency
V_{ds}=50V I_{ds(DC)}=1.1A

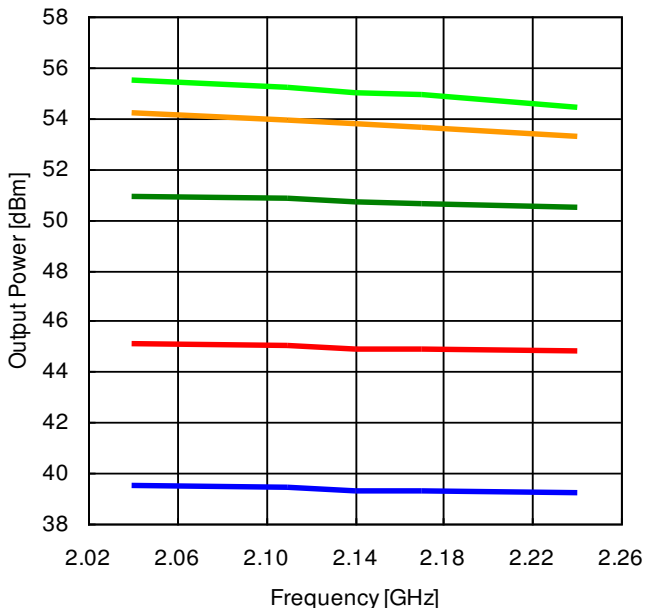

— Pin=20dBm — Pin=26dBm — Pin=32dBm
— Pin=36dBm — Pin=40dBm

Output Power and Drain Efficiency vs. Input Power
V_{ds}=50V I_{ds(DC)}=1.1A f=2.14GHz

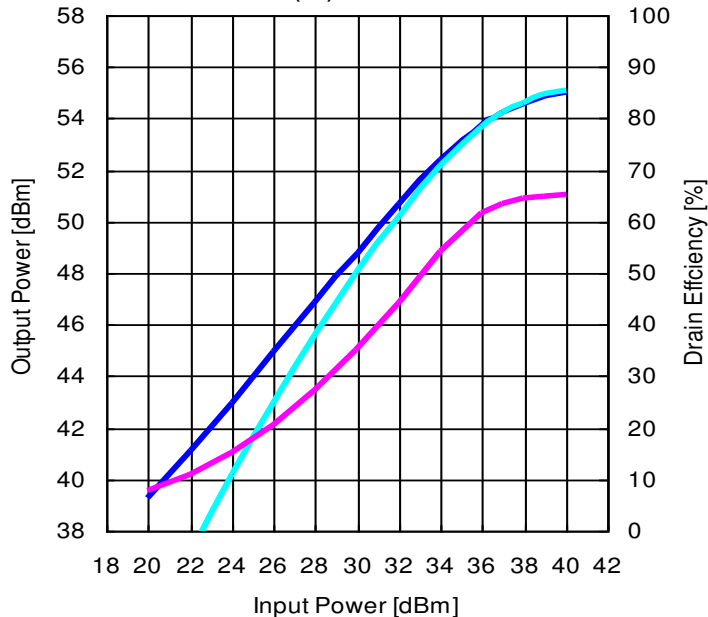

— Pout (AB class) — Pout (class B) — Nd (class B)

Test Fixture

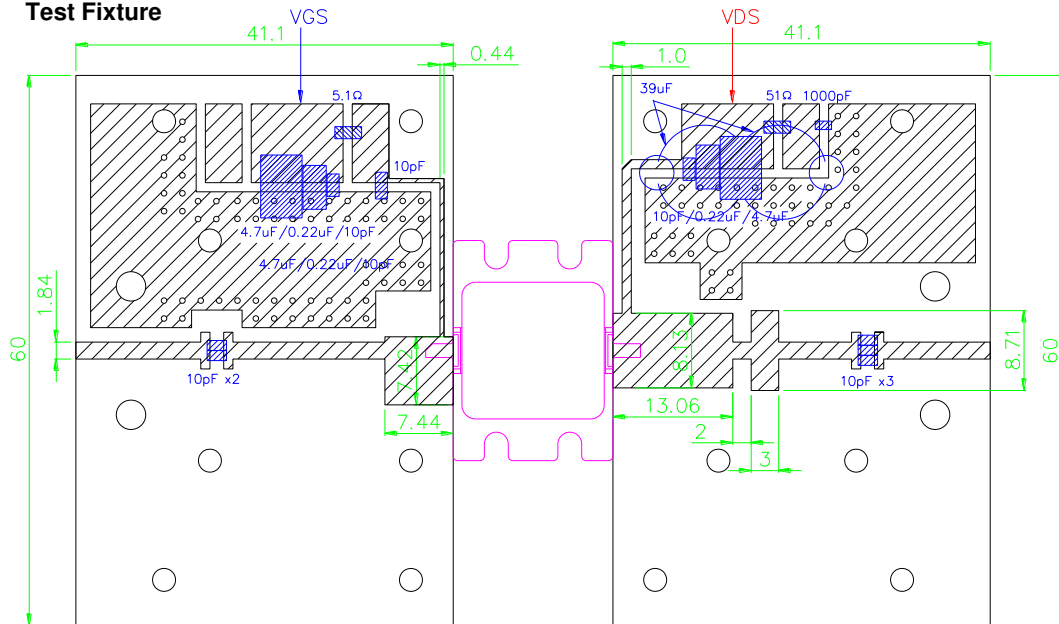

$\epsilon_r = 3.3 @ 1\text{GHz}$
 $h = 0.8\text{mm}$
 $Cu = 18\mu\text{m}$
 Unit: mm

MTTF Calculation - Estimated MTTF -

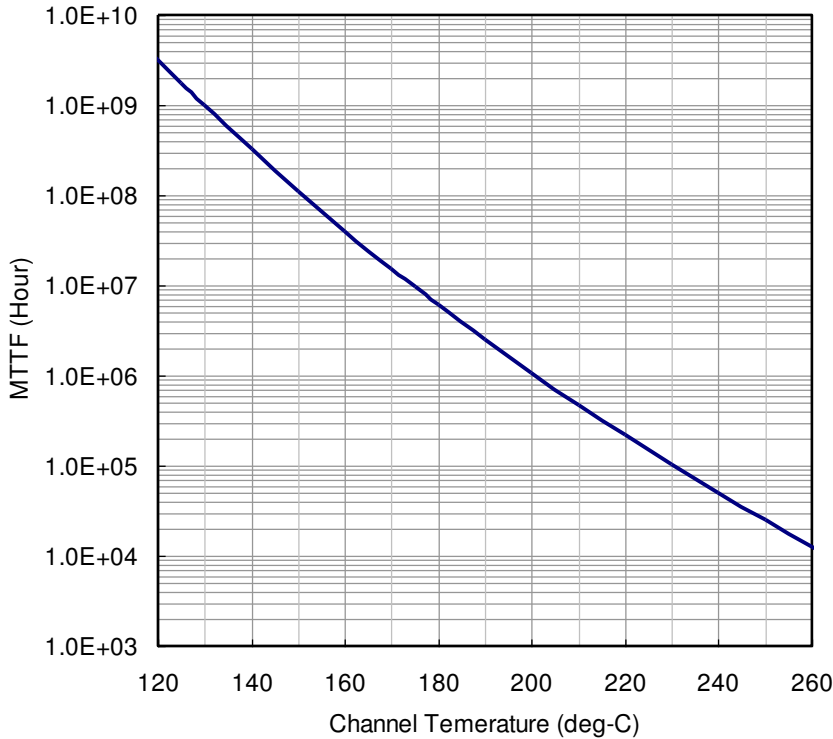

Ea=1.6eV
Confidence Level=90%

Channel Temp (deg-C)	MTTF (Hours)
160	4.05 x 10 ⁷
180	6.07 x 10 ⁶
200	1.07 x 10 ⁶

$$AF = \exp\left[-\frac{Ea}{k}\left(\frac{1}{T_{stress}} - \frac{1}{T_{use}}\right)\right]$$

$$MTTF_{use} = MTTF_{stress} * AF$$

Where;

AF: acceleration factor

Ea: activation energy (1.6 eV)

k: Boltzman's constant (8.62 x 10⁻⁵ eV/K)

T_{stress}: stress temperature (K)

T_{use}: use temperature (K)

ESD characteristic

Test Methodology	Class
Human Body Model (per JESD22-A114)	T.B.D.
Machine Model (per JEIA/ESD22-A115)	T.B.D.

S-Parameters @V_{DS}=50V, I_{DS(DC)}=1.1A, f=0.5 to 4.5 GHz
 Z_l = Z_s = 50 ohm Marker : GHz

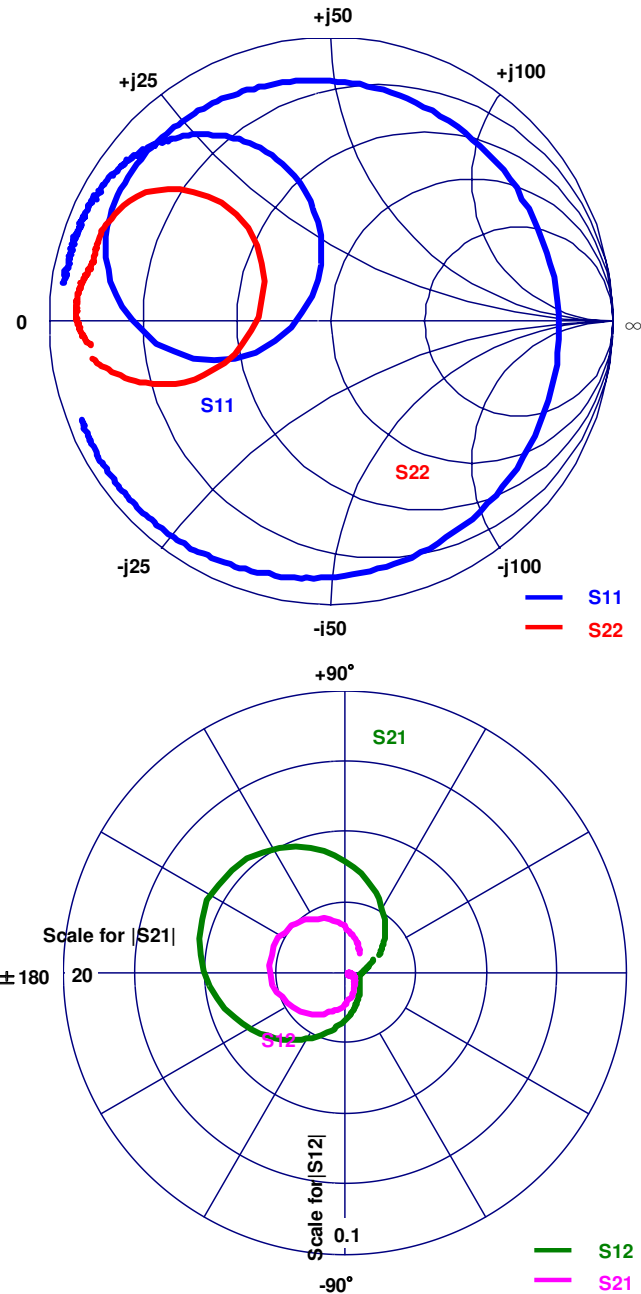

Freq. (GHz)	S11		S21		S12		S22	
	MAG	ANG	MAG	ANG	MAG	ANG	MAG	ANG
0.50	0.96	172.01	2.17	23.64	0.0018	-33.61	0.86	-174.36
0.60	0.95	169.79	1.72	15.63	0.0017	-36.36	0.88	-176.14
0.70	0.95	167.56	1.43	8.47	0.0014	-40.11	0.89	-178.06
0.80	0.96	165.60	1.25	2.44	0.0014	-30.82	0.90	-179.77
0.90	0.95	163.40	1.13	-3.87	0.0013	-26.52	0.91	178.62
1.00	0.95	161.01	1.06	-9.62	0.0012	-22.66	0.91	177.04
1.10	0.96	158.45	1.04	-15.38	0.0012	-24.63	0.91	175.50
1.20	0.95	155.65	1.06	-21.31	0.0014	-21.38	0.90	174.09
1.30	0.94	152.62	1.10	-28.07	0.0018	-20.69	0.90	172.73
1.40	0.94	149.06	1.20	-35.03	0.0018	-18.71	0.90	171.40
1.50	0.92	145.09	1.35	-42.54	0.0022	-20.48	0.89	170.17
1.60	0.91	140.88	1.62	-51.78	0.0028	-22.50	0.88	169.02
1.70	0.88	135.29	2.02	-62.87	0.0042	-38.70	0.87	167.61
1.80	0.84	128.99	2.64	-77.15	0.0052	-53.66	0.87	165.99
1.90	0.76	120.92	3.66	-94.94	0.0078	-69.35	0.87	163.72
2.00	0.62	109.88	5.47	-120.35	0.0123	-94.89	0.87	158.79
2.10	0.30	96.70	8.53	-158.05	0.0201	-134.20	0.80	145.39
2.20	0.44	-161.75	10.85	138.44	0.0273	160.42	0.32	140.05
2.30	0.83	164.26	7.08	80.89	0.0185	103.57	0.53	-156.96
2.40	0.88	144.98	4.19	48.15	0.0115	70.46	0.76	-164.78
2.50	0.88	132.59	2.70	26.70	0.0085	53.38	0.86	-171.19
2.60	0.88	121.04	1.93	10.16	0.0063	40.03	0.90	-175.39
2.70	0.86	108.60	1.48	-3.23	0.0054	27.79	0.93	-178.47
2.80	0.85	93.79	1.20	-16.74	0.0043	18.10	0.95	179.14
2.90	0.83	75.17	1.02	-30.74	0.0040	6.89	0.96	177.24
3.00	0.82	51.79	0.89	-46.03	0.0037	-5.81	0.97	175.53
3.10	0.80	23.73	0.77	-62.47	0.0035	-13.66	0.97	174.05
3.20	0.81	-7.76	0.66	-80.14	0.0033	-34.48	0.98	172.53
3.30	0.84	-38.09	0.54	-97.83	0.0030	-51.03	0.98	171.36
3.40	0.87	-64.08	0.43	-113.31	0.0022	-69.41	0.98	169.81
3.50	0.89	-85.16	0.34	-126.53	0.0017	-98.91	0.98	168.52
3.60	0.92	-101.21	0.27	-137.41	0.0011	-103.05	0.98	167.35
3.70	0.93	-113.84	0.22	-146.43	0.0010	-151.74	0.98	166.20
3.80	0.94	-123.67	0.19	-154.19	0.0016	-171.09	0.97	165.06
3.90	0.95	-131.63	0.16	-160.98	0.0012	160.02	0.97	163.63
4.00	0.95	-138.16	0.14	-166.71	0.0019	148.10	0.97	161.82
4.10	0.95	-143.57	0.13	-172.25	0.0016	136.95	0.96	160.34
4.20	0.96	-148.18	0.12	-176.74	0.0023	132.12	0.95	158.82
4.30	0.95	-151.76	0.11	178.23	0.0027	119.90	0.95	157.11
4.40	0.95	-155.47	0.11	173.50	0.0027	139.03	0.94	155.24
4.50	0.95	-158.46	0.12	167.36	0.0031	114.94	0.95	152.66

V_{gg}-Peak

V_{dd}-Peak

RF Input

RF Output

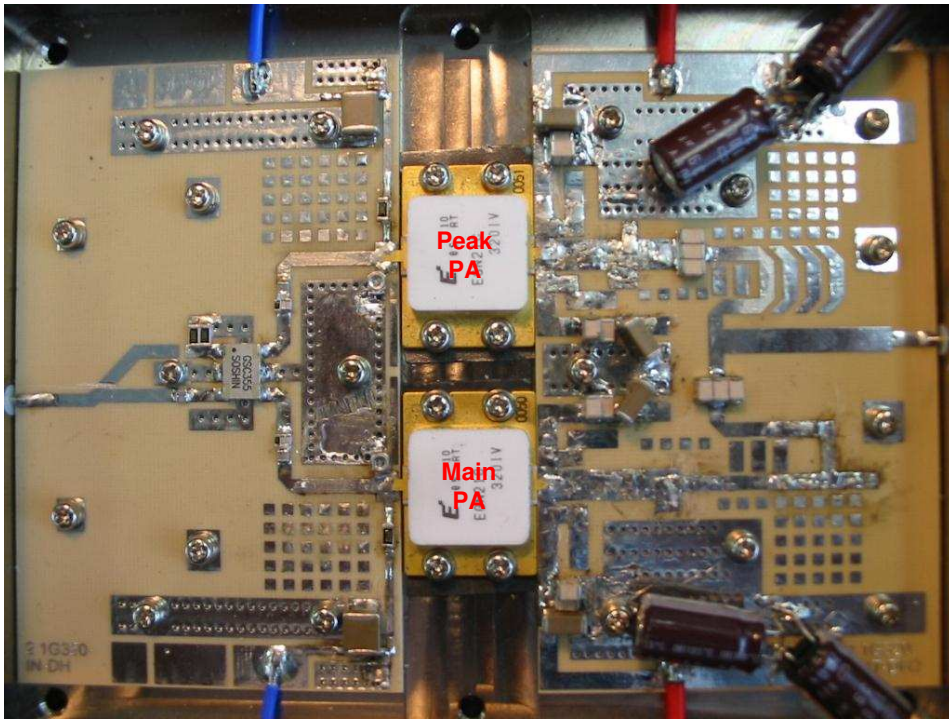

CS-3376C
t=0.8mm, ε_r=3.3

V_{gg}-Main

V_{dd}-Main

Doherty Amplifier characteristics

High Voltage - High Power GaN-HEMT

Test conditions : $V_{ds}=50V$, $I_{ds-main}=1.1A$, $V_{gs-peak}=-3.5V$, Pulse Duty : 10% (6 μ s/60 μ s)

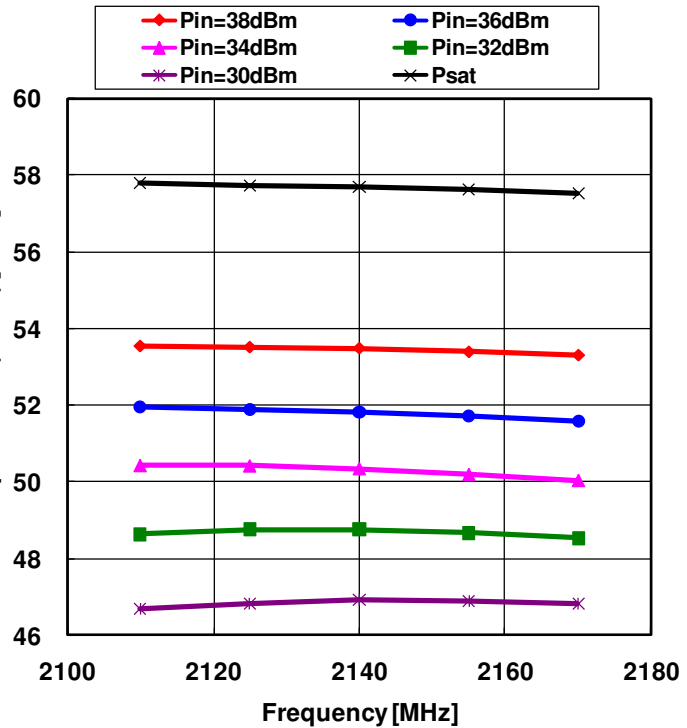
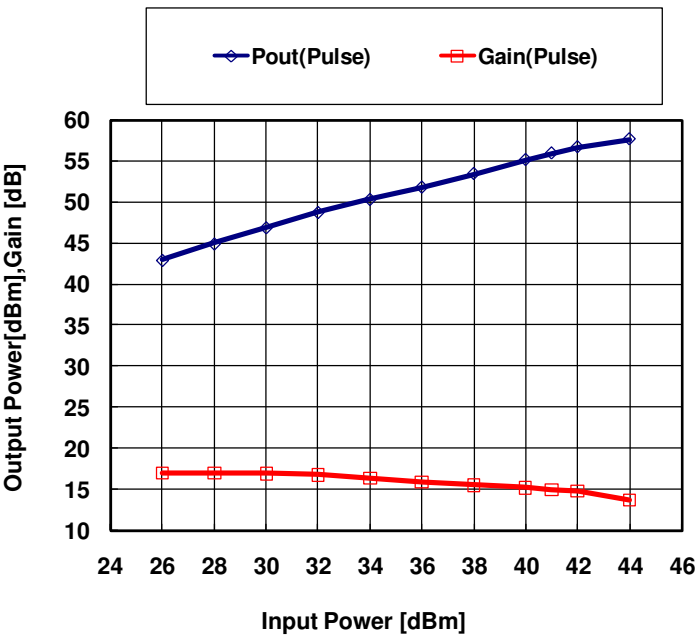

Test conditions : $V_{ds}=50V$, $I_{ds-main}=1.1A$, $V_{gs-peak}=-3.5V$
 W-CDMA 2-carrier, 5MHz Spacing, PAR=7.8dB(0.01%),
 $f_1=2137.5MHz$, $f_2=2142.5MHz$

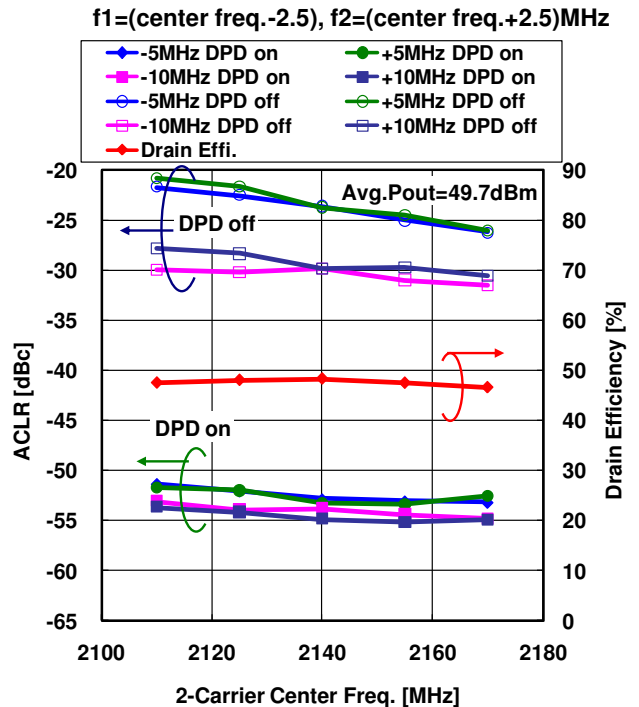
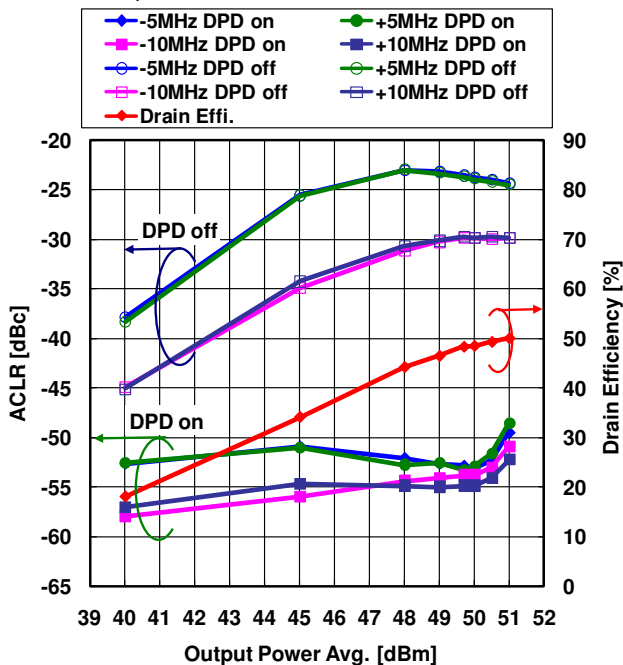

IV Package Outline Metal-Ceramic Hermetic Package

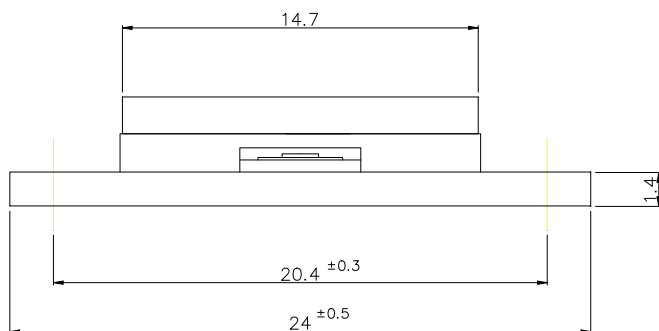
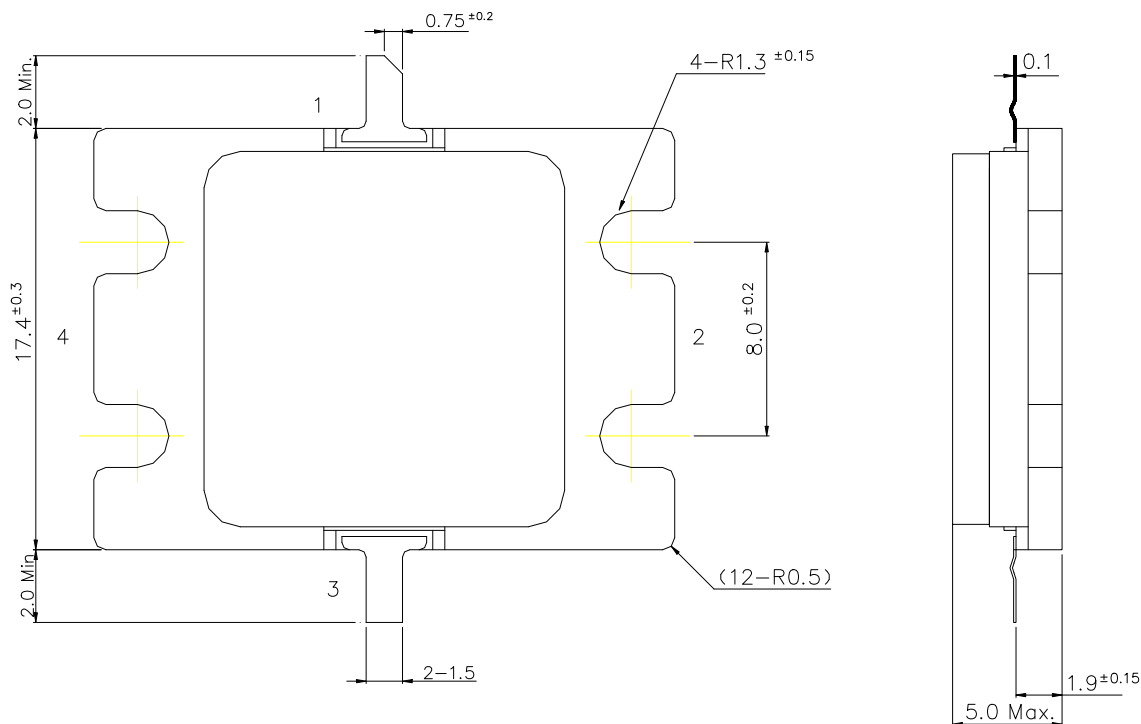

- 1 : Gate
 - 2 : Source(Flange)
 - 3 : Drain
 - 4 : Source(Flange)
- Unit : mm

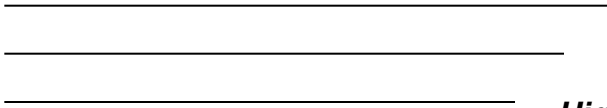

EGN21C320IV

High Voltage - High Power GaN-HEMT

For further information please contact:

<http://global-sei.com/Electro-optic/about/office.html>