

### FEATURES

- High Voltage Operation :  $V_{DS}=50V$
- High Power : 50.3dBm (typ.) @  $P_{sat}$
- High Efficiency: 70%(typ.) @  $P_{sat}$
- Power Gain : 18dB(typ.) @  $f=2.14GHz$
- Proven Reliability

### DESCRIPTION

SEI's GaN-HEMT offers high efficiency, ease of matching, greater consistency and broad bandwidth for high power L-band amplifiers with 50V operation, and gives you higher gain.

This new product is ideally suited for use in 2.14GHz W-CDMA & LTE design requirements as it offers high gain, long term reliability and ease of use.



### ABSOLUTE MAXIMUM RATINGS (Case Temperature $T_c=25deg.C$ )

Item	Symbol	Condition	Rating	Unit
Operating-Voltage	$V_{DS}$		55	V
Drain-Source Voltage	$V_{DS}$	$V_{GS}=-8V$	160	V
Gate-Source Voltage	$V_{GS}$		-15	V
Total Power Dissipation	$P_t$		97.8	W
Storage Temperature	$T_{stg}$		-65 to +175	deg.C
Channel Temperature	$T_{ch}$		250	deg.C

### RECOMMENDED OPERATING CONDITION

Item	Symbol	Condition	Limit	Unit
DC Input Voltage	$V_{ds}$		$\leq 55$	V
Forward Gate Current	$I_{GF}$	$R_G=5ohm$	$\leq 102$	mA
Reverse Gate Current	$I_{GR}$	$R_G=5ohm$	$\geq -3.9$	mA
Channel Temperature	$T_{ch}$		$\leq 180$	deg.C
Average Output Power	$P_{ave.}$		$\leq 47.3$	dBm

### ELECTRICAL CHARACTERISTICS (Case Temperature $T_c=25deg.C$ )

Item	Symbol	Condition	Limit			Unit
			Min.	Typ.	Max.	
Pinch-Off Voltage	$V_p$	$V_{DS}=50V$ $I_{DS}=27mA$	-1.0	-1.5	-2.0	V
Saturated Power	$P_{sat} *1$	$V_{DS}=50V$	49.5	50.3	-	dBm
Drain Efficiency	$\eta_d *2$	$I_{DS}(DC)=400mA$	28	32	-	%
Power Gain	$G_p *2$		17.0	18.0	-	dB
3 <sup>rd</sup> Order Inter-modulation Distortion	$IM3 *2$		-28	-32	-	dBc
Thermal Resistance	$R_{th}$	Channel to Case at 52.5W $P_{DC}$	-	2.0	2.3	deg.C/W

\*1 : 10%-duty RF pulse (DC supply constant),  $f=2.14GHz$

\*2 :  $P_{out} = 42dBm$ ,  $f_0=2.135GHz$ ,  $f_1=2.145GHz$ , W-CDMA(3GPP3.4 12-00) BS-1 64ch 47.5% clipping modulation (Peak/Avg.=8.5dB@0.01% Probability on CCDF).

<b>RoHS COMPLIANCE</b>	<b>Yes</b>
------------------------	------------



### MTTF Calculation - Estimated MTTF -

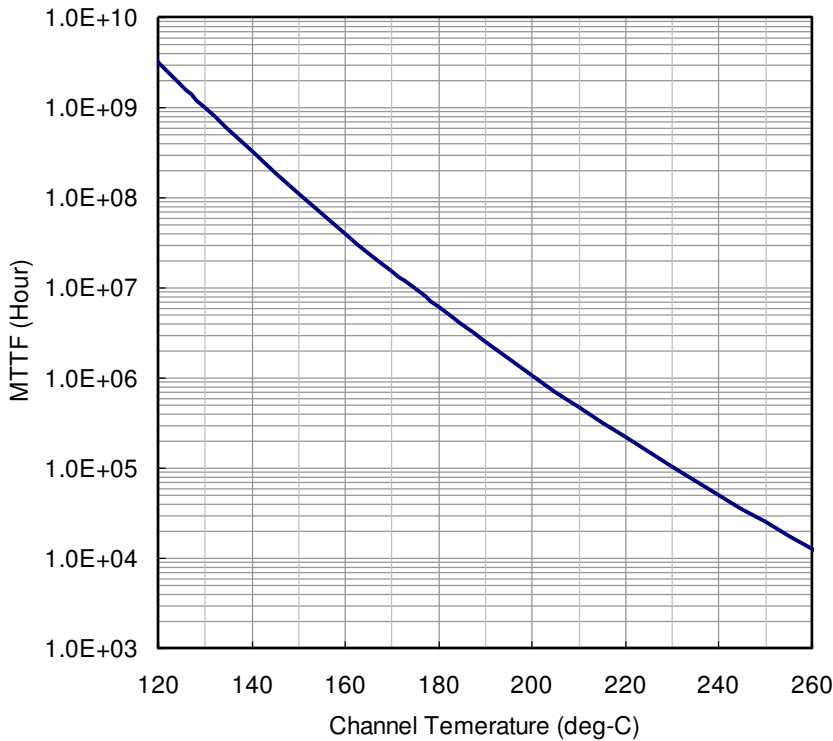

Ea=1.6eV  
Confidence Level=90%

Channel Temp (deg-C)	MTTF (Hours)
160	4.05 x 10 <sup>7</sup>
180	6.07 x 10 <sup>6</sup>
200	1.07 x 10 <sup>6</sup>

$$AF = \exp\left[-\frac{Ea}{k}\left(\frac{1}{T_{stress}} - \frac{1}{T_{use}}\right)\right]$$

$$MTTF_{use} = MTTF_{stress} * AF$$

Where;

AF: acceleration factor

Ea: activation energy (1.6 eV)

k: Boltzman's constant (8.62 x 10<sup>-5</sup> eV/K)

T<sub>stress</sub>: stress temperature (K)

T<sub>use</sub>: use temperature (K)

### ESD characteristic

Test Methodology	Class
Human Body Model (per JESD22-A114)	1B
Machine Model (per JEIA/ESD22-A115)	A

- Reference DATA -

S-Parameters @V<sub>DS</sub>=50V, I<sub>DS(DC)</sub>=300mA, f=0.5 to 4.5 GHz  
 Z<sub>i</sub> = Z<sub>s</sub> = 50 ohm      Marker : 2.14GHz

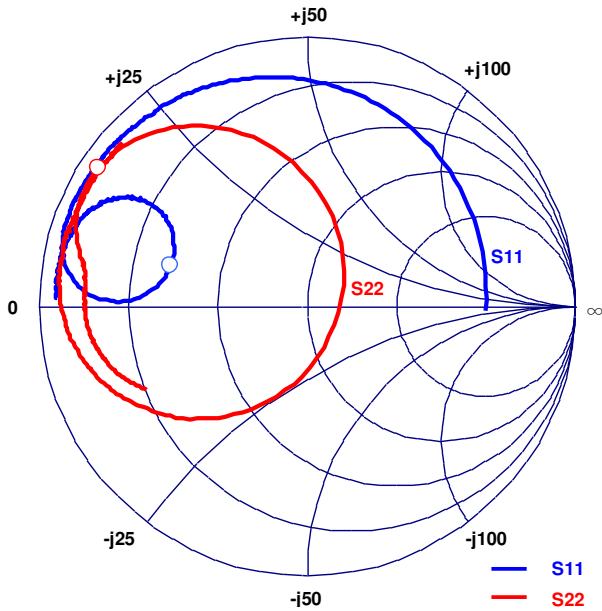

Freq. GHz	S11		S21		S12		S22	
	MAG	ANG	MAG	ANG	MAG	ANG	MAG	ANG
0.50	0.93	178.34	5.77	32.71	0.004	-27.93	0.67	-152.62
0.60	0.94	175.81	4.61	23.97	0.004	-25.86	0.72	-157.40
0.70	0.94	173.50	3.82	16.22	0.003	-24.90	0.76	-161.52
0.80	0.94	171.83	3.29	9.12	0.003	-17.55	0.78	-165.49
0.90	0.94	169.46	2.95	2.13	0.003	-13.17	0.80	-168.94
1.00	0.93	167.43	2.71	-4.46	0.003	-6.60	0.81	-172.13
1.10	0.93	165.09	2.58	-10.90	0.003	-5.13	0.82	-175.02
1.20	0.92	163.06	2.52	-17.64	0.003	-7.75	0.83	-177.72
1.30	0.91	160.75	2.51	-24.39	0.004	5.78	0.83	179.69
1.40	0.89	158.14	2.62	-31.70	0.005	0.88	0.83	177.50
1.50	0.87	155.60	2.77	-40.76	0.006	-0.27	0.83	175.32
1.60	0.85	152.87	3.03	-49.68	0.006	-7.41	0.83	173.41
1.70	0.81	150.16	3.42	-60.92	0.008	-15.25	0.84	171.21
1.80	0.75	147.90	3.93	-74.35	0.010	-22.34	0.85	169.12
1.90	0.67	147.02	4.61	-90.86	0.012	-38.27	0.88	166.12
2.00	0.58	150.12	5.35	-111.09	0.015	-60.13	0.91	161.03
2.10	0.53	158.90	6.08	-134.35	0.017	-81.20	0.94	151.94
2.20	0.55	170.58	6.68	-160.40	0.019	-107.85	0.90	137.93
2.30	0.65	177.91	6.99	170.59	0.020	-138.17	0.75	118.18
2.40	0.77	178.08	6.84	138.32	0.020	-169.78	0.46	87.92
2.50	0.88	173.34	5.78	104.05	0.017	155.34	0.12	-10.41
2.60	0.94	167.29	4.24	74.99	0.013	125.34	0.39	-112.17
2.70	0.95	162.38	2.98	54.18	0.010	103.11	0.60	-135.91
2.80	0.95	158.60	2.15	39.55	0.007	89.73	0.73	-149.65
2.90	0.95	155.53	1.62	27.81	0.005	81.08	0.80	-158.53
3.00	0.95	152.46	1.27	18.05	0.004	70.79	0.85	-164.97
3.10	0.94	149.96	1.03	10.66	0.004	84.45	0.88	-170.44
3.20	0.95	146.88	0.86	3.25	0.003	70.88	0.90	-175.14
3.30	0.94	143.66	0.75	-3.19	0.004	84.31	0.91	-178.78
3.40	0.93	140.47	0.66	-9.44	0.003	86.56	0.92	177.62
3.50	0.93	137.06	0.61	-15.25	0.004	84.50	0.93	174.47
3.60	0.92	132.68	0.57	-21.07	0.005	72.51	0.93	171.17
3.70	0.92	128.24	0.55	-27.00	0.004	74.57	0.93	168.47
3.80	0.91	122.60	0.55	-32.91	0.005	72.14	0.93	165.82
3.90	0.90	115.51	0.56	-40.31	0.005	61.56	0.93	162.84
4.00	0.88	107.05	0.58	-47.68	0.006	42.28	0.93	159.71
4.10	0.86	96.25	0.63	-57.21	0.007	36.94	0.93	156.35
4.20	0.82	81.62	0.70	-68.23	0.006	23.27	0.93	152.88
4.30	0.77	61.85	0.79	-81.30	0.007	6.67	0.92	148.90
4.40	0.71	34.19	0.89	-97.78	0.007	-20.41	0.92	144.48
4.50	0.67	-1.61	0.98	-117.86	0.007	-44.32	0.92	138.81

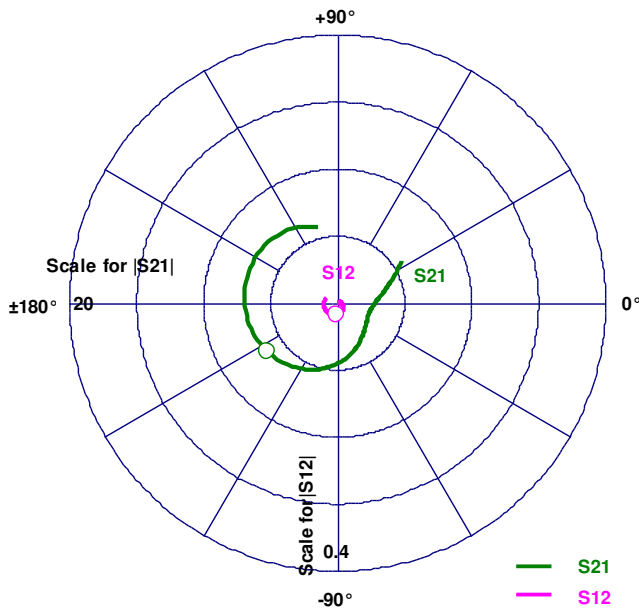

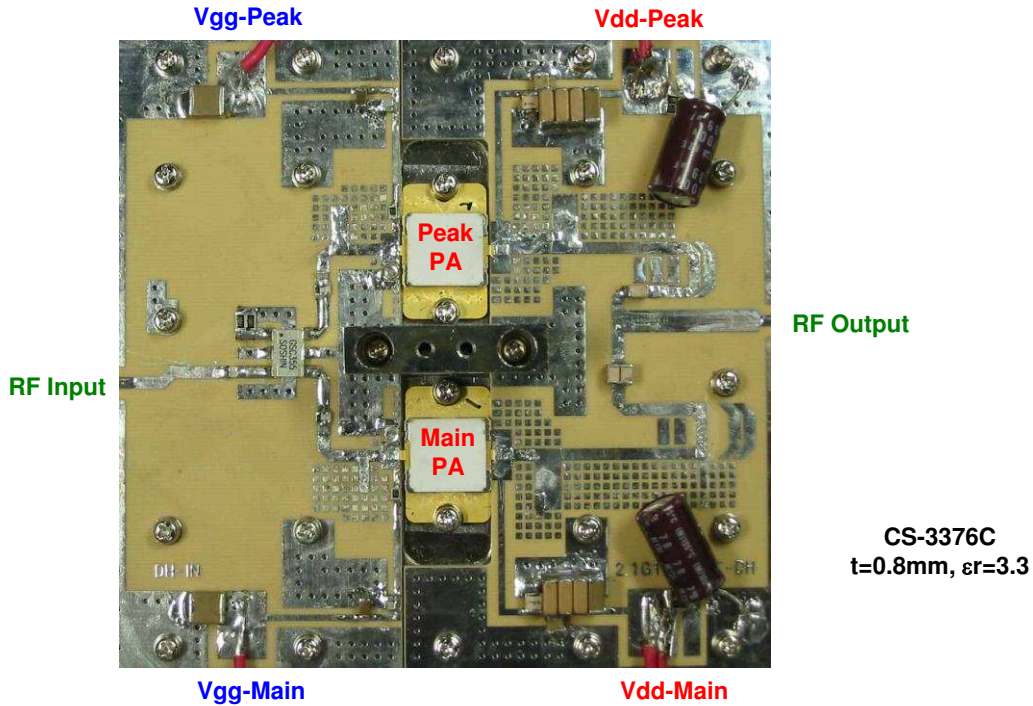

**Test Fixture**

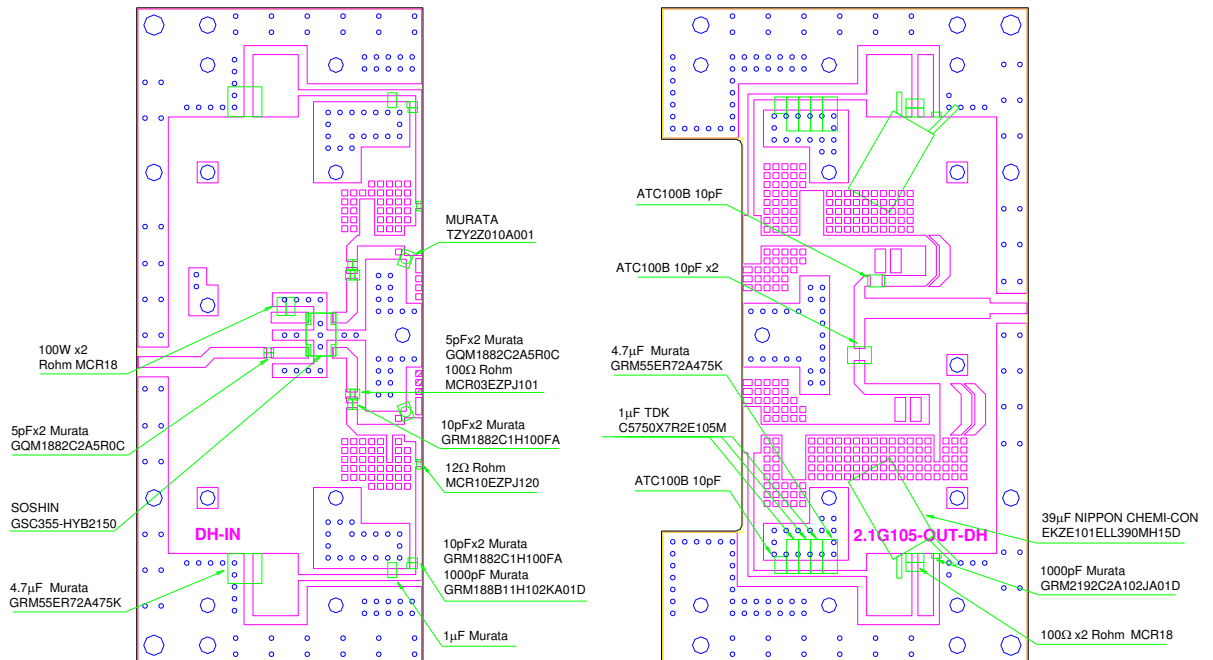

**CS3376C, t=0.8mm, Er=3.5**

### Doherty Amplifier characteristics

Test conditions :  $V_{ds}=50V$ ,  $I_{ds-main}=400mA$ ,  $V_{gs-peak}=-3.5V$ , Pulse Duty : 10% (6us/60us)

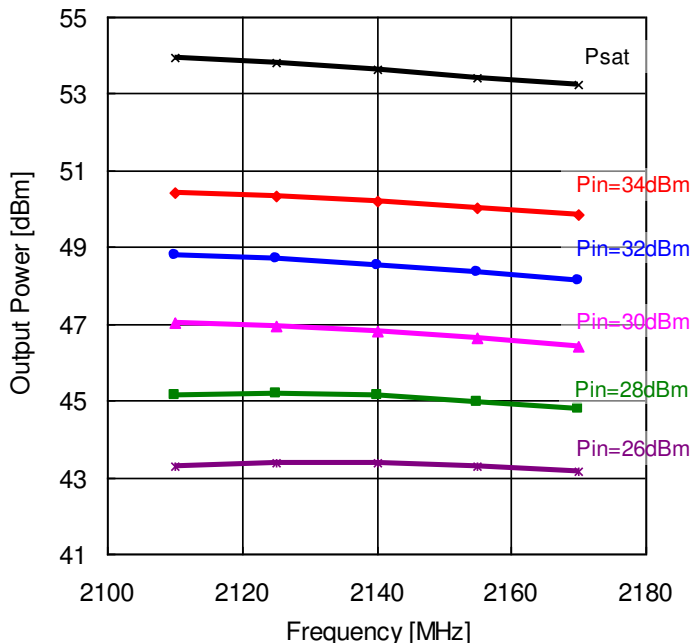
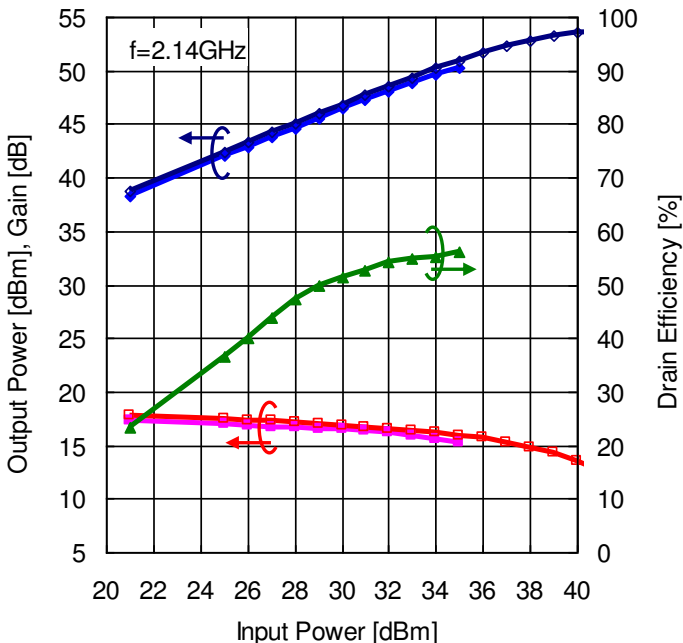

Test conditions :  $V_{ds}=50V$ ,  $I_{ds-main}=400mA$ ,  $V_{gs-peak}=-3.5V$

W-CDMA 2-carrier, 5MHz Spacing, PAR=7.8dB(0.01%),  $f_1=2137.5MHz$ ,  $f_2=2142.5MHz$

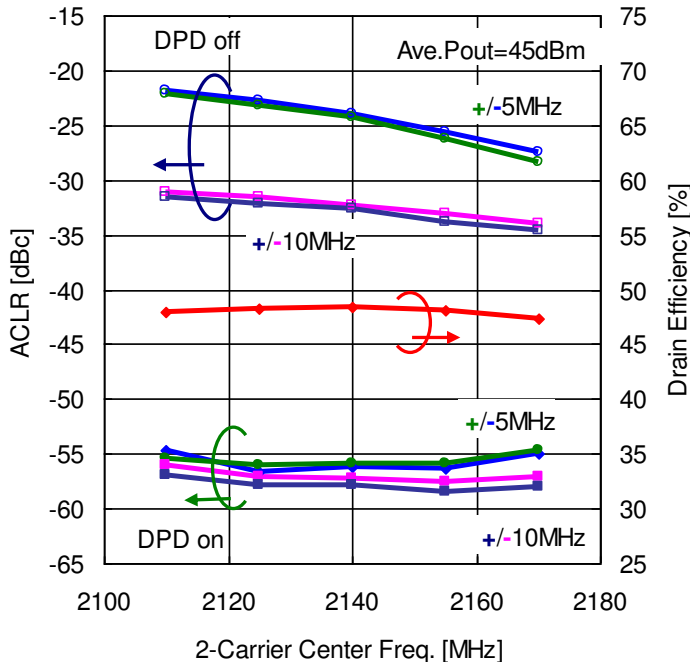
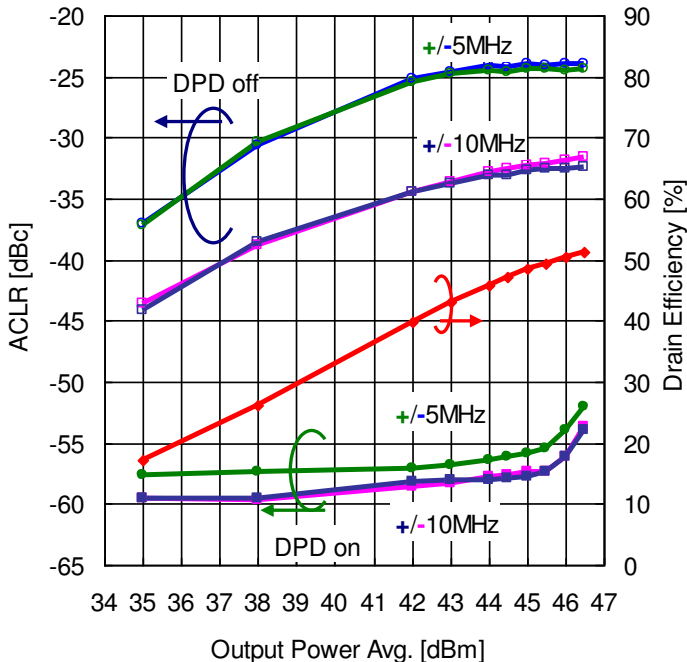

### I2D Package Outline Metal-Ceramic Hermetic Package

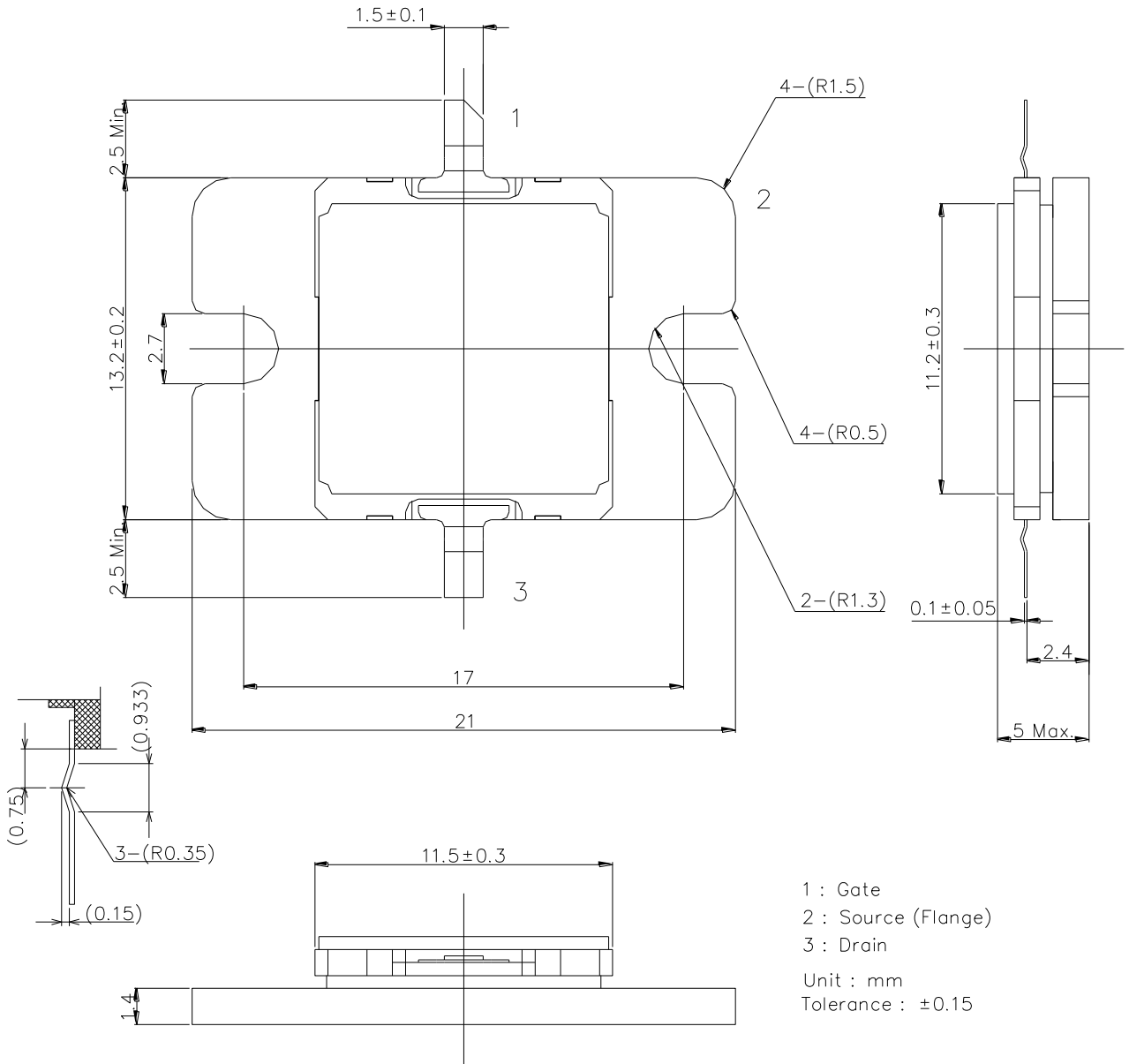

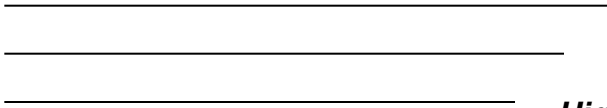

# ***EGN21C105I2D***

***High Voltage - High Power GaN-HEMT***

**For further information please contact:**

**<http://global-sei.com/Electro-optic/about/office.html>**