

FEATURES

- High Voltage Operation : $V_{DS}=50V$
- High Power : 50.3dBm (typ.) @ P_{sat}
- High Efficiency: 60%(typ.) @ P_{sat}
- Power Gain :17dB(typ.) @ $f=2.1GHz$
- Proven Reliability

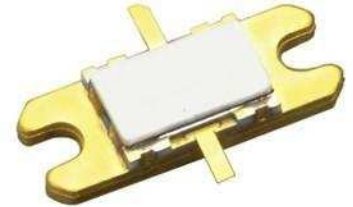

DESCRIPTION

SEDI's GaN-HEMT offers high efficiency, ease of matching, greater consistency and broad bandwidth for high power L-band amplifiers with 50V operation, and gives you higher gain.

This new product is ideally suited for use in 2.1GHz LTE design requirements as it offers high gain, long term reliability and ease of use.

ABSOLUTE MAXIMUM RATINGS (Case Temperature $T_c=25deg.C$)

Item	Symbol	Condition	Rating	Unit
Operating-Voltage	V_{DS}		55	V
Drain-Source Voltage	V_{DS}	$V_{GS}=-8V$	160	V
Gate-Source Voltage	V_{GS}		-15	V
Total Power Dissipation	P_t		97.8	W
Storage Temperature	T_{stg}		-65 to +175	deg.C
Channel Temperature	T_{ch}		250	deg.C

RECOMMENDED OPERATING CONDITION

Item	Symbol	Condition	Limit	Unit
DC Input Voltage	V_{DS}		≤ 55	V
Forward Gate Current	I_{GF}	$R_G=5\text{ ohm}$	≤ 102	mA
Reverse Gate Current	I_{GR}	$R_G=5\text{ ohm}$	≥ -3.9	mA
Channel Temperature	T_{ch}		≤ 180	deg.C
Average Output Power	$P_{ave.}$		≤ 47.5	dBm

ELECTRICAL CHARACTERISTICS (Case Temperature $T_c=25deg.C$)

Item	Symbol	Condition	Limit			Unit
			Min.	Typ.	Max.	
Pinch-Off Voltage	V_p	$V_{DS}=50V\ I_{DS}=27mA$	-1.0	-1.5	-2.0	V
Saturated Power	$P_{sat} *1$	$V_{DS}=50V$	49.5	50.3	-	dBm
Drain Efficiency	$\eta_d *2$	$I_{DS}(DC)=400mA$	28	32	-	%
Power Gain	$G_p *2$	$f=2.1GHz$	16	17	-	dB
Thermal Resistance	R_{th}	Channel to Case at 52.5W P_{DC}	-	2.0	2.3	deg.C/W

RoHS COMPLIANCE	Yes
-----------------	-----

*1 : 10%-duty RF pulse (DC supply constant)

*2 : $P_{out} = 42.5dBm$, CW modulation Signal (W-CDMA)

Output Power vs. Frequency
VDS=50V, IDS(DC)=400mA

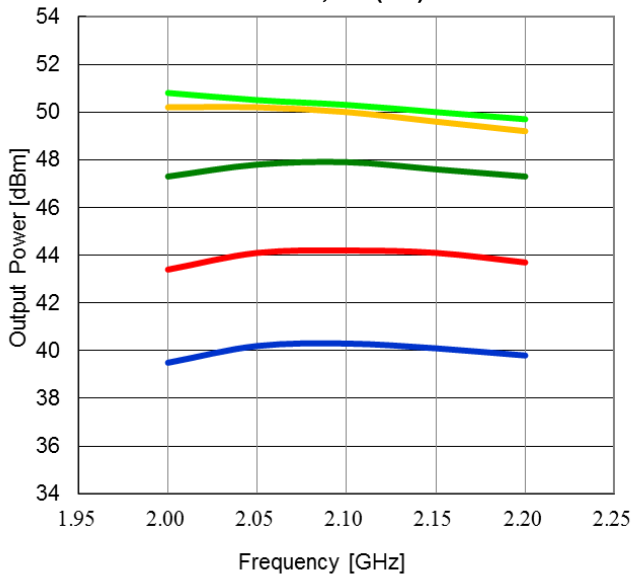

Output Power and Drain Efficiency vs. Input Power
VDS=50V, IDS(DC)=400mA, f=2.1GHz

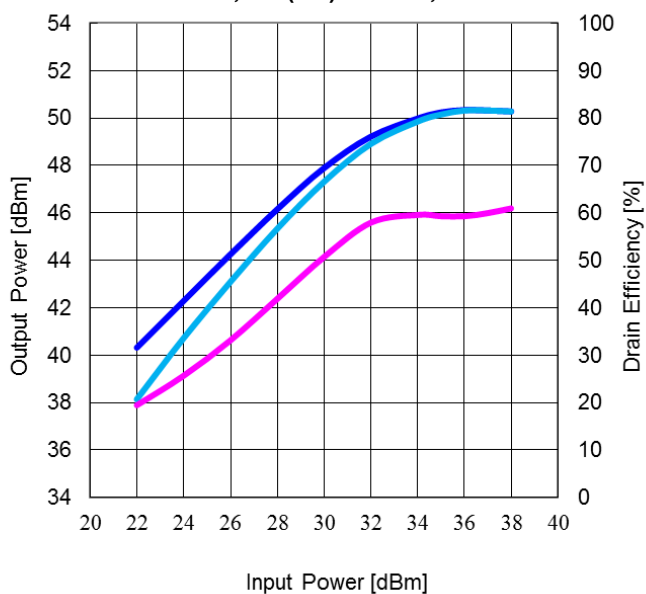

— Pin=22dBm — Pin=26dBm — Pin=30dBm
— Pin=34dBm — Pin=38dBm

— Pout(class AB) — Pout(class B) — Nd(class B)

Pulse Signal (10%-duty, DC : constant)

Test Fixture

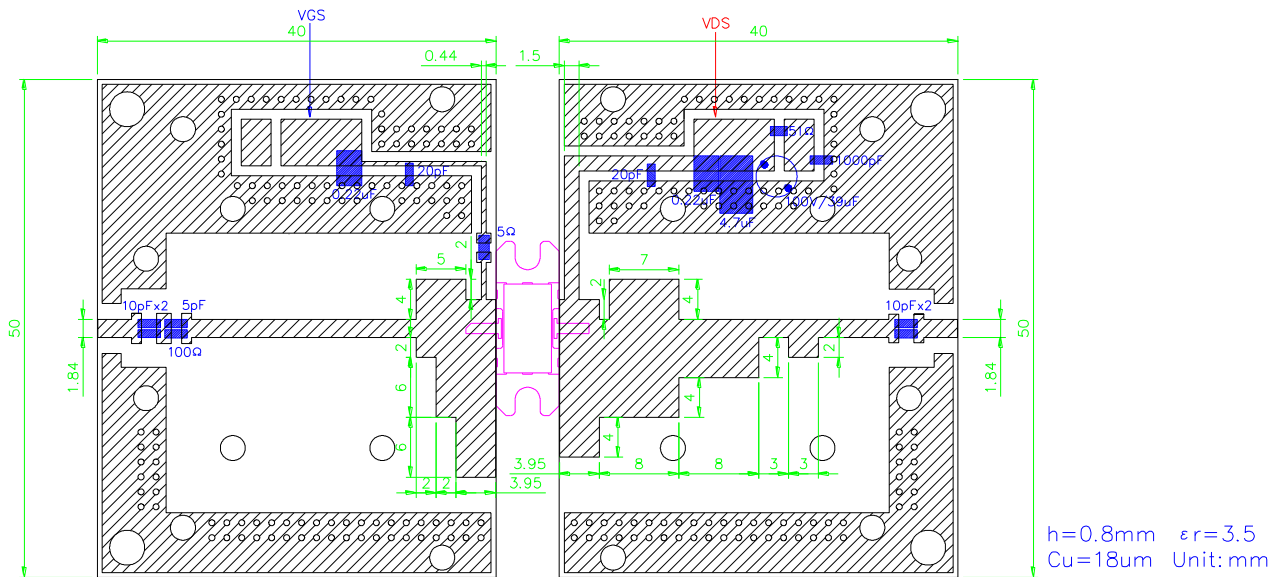

- Reference DATA -

S-Parameters @V_{DS}=50V, I_{DS(DC)}=400mA, f=0.5 to 4.5GHz
 Z_l = Z_s = 50 ohm Marker : 2.1GHz

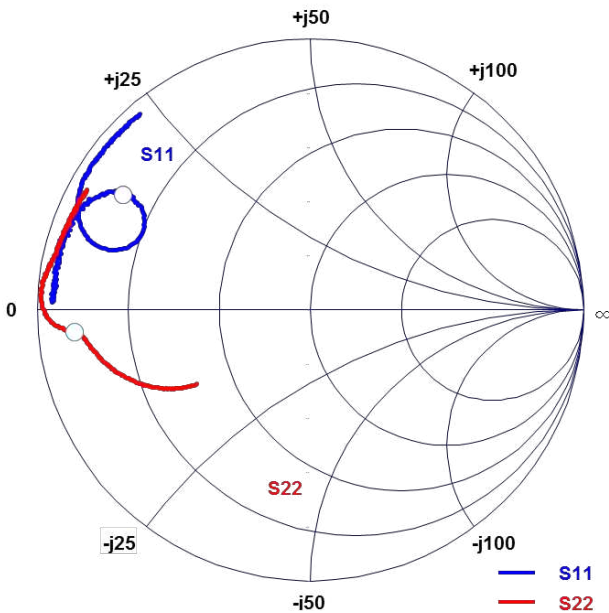

Freq. GHz	S11		S21		S12		S22	
	MAG	ANG	MAG	ANG	MAG	ANG	MAG	ANG
0.50	0.94	177.93	6.66	55.10	0.005	-9.04	0.50	-146.58
0.60	0.94	175.93	5.45	48.10	0.005	-7.91	0.55	-148.29
0.70	0.94	173.43	4.56	41.33	0.005	-8.13	0.59	-150.65
0.80	0.94	171.95	3.93	35.84	0.004	-0.40	0.63	-152.91
0.90	0.94	170.28	3.43	29.89	0.004	5.72	0.67	-155.37
1.00	0.94	168.04	3.05	24.34	0.004	17.52	0.70	-157.71
1.10	0.95	166.31	2.78	19.30	0.004	19.70	0.72	-159.97
1.20	0.94	164.47	2.56	14.13	0.004	23.53	0.75	-161.97
1.30	0.94	163.18	2.39	9.15	0.005	28.63	0.76	-164.15
1.40	0.93	160.55	2.28	4.01	0.005	31.53	0.78	-166.04
1.50	0.93	159.31	2.20	-0.96	0.005	32.39	0.80	-167.70
1.60	0.92	157.20	2.14	-6.63	0.006	33.96	0.81	-169.28
1.70	0.91	155.97	2.15	-11.93	0.007	35.54	0.82	-170.83
1.80	0.91	153.27	2.17	-18.67	0.008	34.18	0.83	-172.22
1.90	0.88	151.33	2.24	-25.99	0.008	31.51	0.84	-173.29
2.00	0.85	149.23	2.37	-35.23	0.009	26.42	0.85	-173.98
2.10	0.81	148.24	2.56	-45.80	0.011	16.27	0.87	-174.57
2.20	0.75	148.11	2.74	-60.96	0.011	3.24	0.89	-175.03
2.30	0.69	152.12	2.83	-80.36	0.011	-11.38	0.93	-176.27
2.40	0.69	159.04	2.67	-101.96	0.009	-31.01	0.97	-178.75
2.50	0.76	163.13	2.27	-123.12	0.007	-48.05	0.99	178.23
2.60	0.83	162.79	1.80	-140.16	0.004	-66.56	0.99	175.20
2.70	0.89	160.29	1.39	-152.96	0.002	-87.35	0.98	173.06
2.80	0.92	157.69	1.09	-162.49	0.000	66.69	0.97	171.12
2.90	0.94	155.63	0.87	-169.68	0.001	97.27	0.96	169.66
3.00	0.95	153.45	0.71	-176.08	0.003	89.39	0.96	168.36
3.10	0.95	151.64	0.58	178.72	0.003	85.16	0.95	167.08
3.20	0.96	150.06	0.50	174.12	0.004	83.92	0.95	166.06
3.30	0.96	148.31	0.43	170.17	0.005	83.28	0.95	164.92
3.40	0.96	146.78	0.37	166.93	0.006	87.37	0.95	163.76
3.50	0.96	145.50	0.32	163.39	0.007	83.83	0.94	162.70
3.60	0.96	143.97	0.29	160.16	0.008	83.08	0.95	161.55
3.70	0.96	142.69	0.26	156.68	0.008	84.86	0.94	160.39
3.80	0.96	141.10	0.23	153.73	0.009	81.64	0.94	159.65
3.90	0.96	139.95	0.21	150.73	0.010	78.96	0.94	158.13
4.00	0.96	138.23	0.19	147.02	0.012	82.22	0.94	157.19
4.10	0.96	137.19	0.18	143.85	0.013	75.92	0.93	156.20
4.20	0.96	135.65	0.17	141.11	0.015	72.11	0.94	154.97
4.30	0.96	134.05	0.15	137.77	0.016	67.40	0.93	153.81
4.40	0.95	132.60	0.14	134.55	0.018	65.70	0.93	152.64
4.50	0.96	130.79	0.14	131.90	0.019	62.22	0.93	151.47

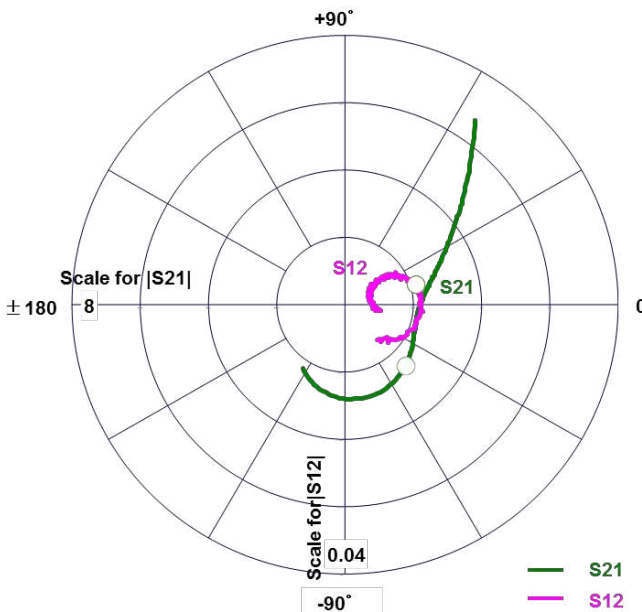

MTTF Calculation - Estimated MTTF -

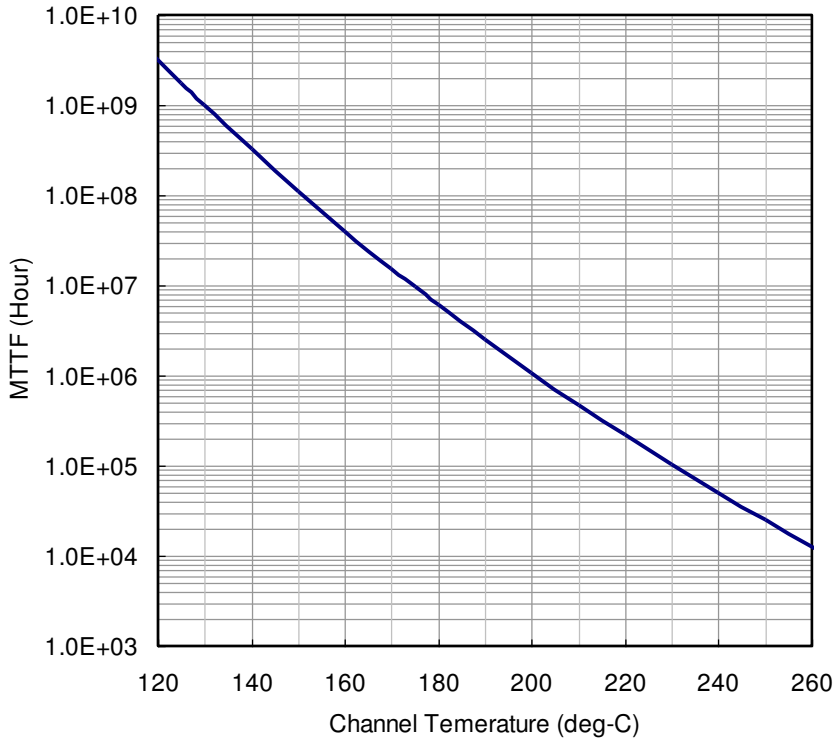

Ea=1.6eV
Confidence Level=90%

Channel Temp (deg-C)	MTTF (Hours)
160	4.05 x 10 ⁷
180	6.07 x 10 ⁶
200	1.07 x 10 ⁶

$$AF = \exp\left[-\frac{Ea}{k}\left(\frac{1}{T_{stress}} - \frac{1}{T_{use}}\right)\right]$$

$$MTTF_{use} = MTTF_{stress} * AF$$

Where;

AF: acceleration factor

Ea: activation energy (1.6 eV)

k: Boltzman's constant (8.62×10^{-5} eV/K)

T_{stress}: stress temperature (K)

T_{use}: use temperature (K)

ESD characteristic

Test Methodology	Class
Human Body Model (per JESD22-A114)	1A
Machine Model (per JEIA/ESD22-A115)	A

MK Package Outline

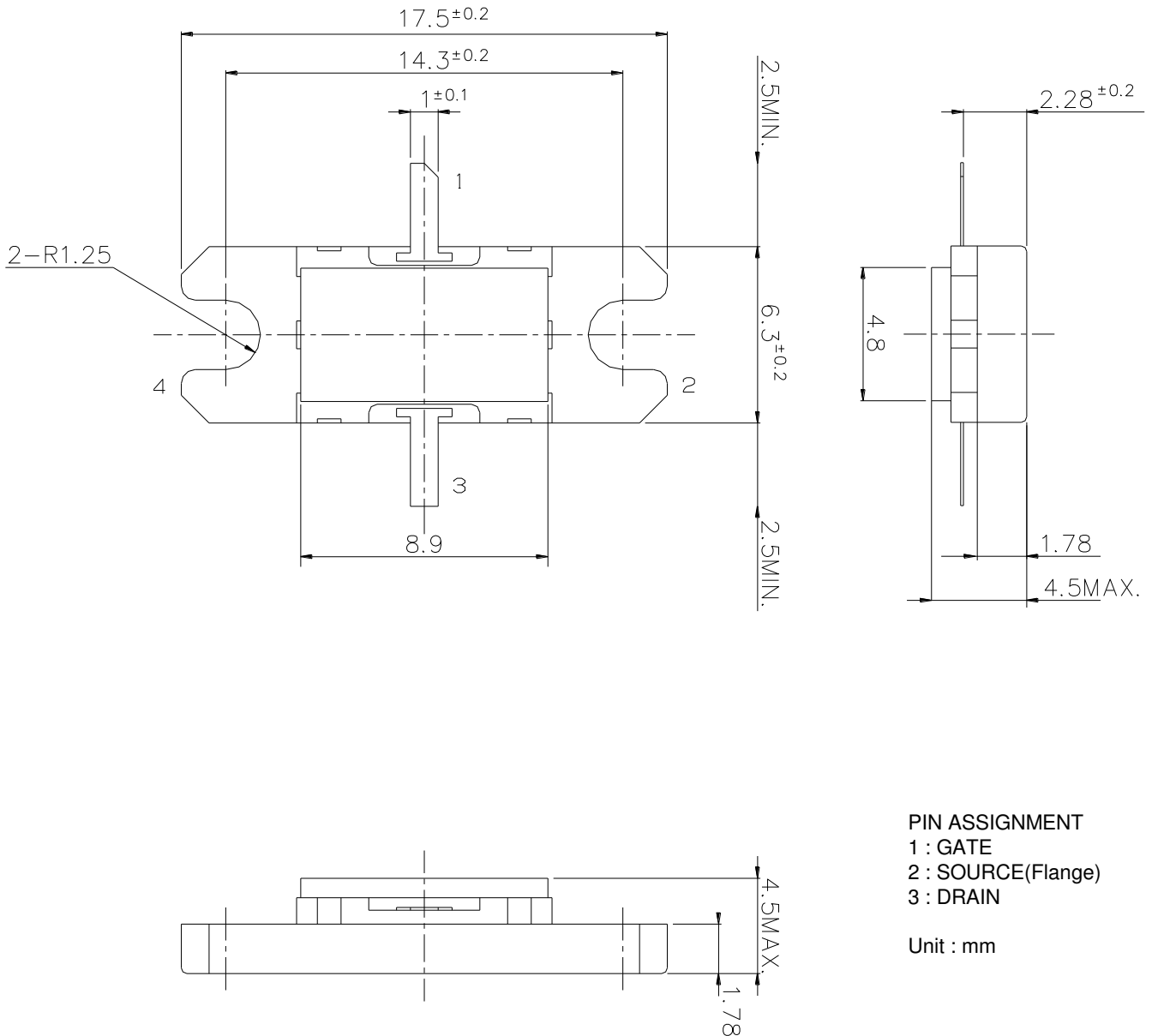



SGN21C105MK

High Voltage - High Power GaN-HEMT

For further information please contact:

<http://global-sei.com/Electro-optic/about/office.html>