

## 10Gb/s SFP Optical Transceiver Module

### SPP5100ZR-GL

(Multi protocol, 80km 1550nm Cooled EA-DFB-LD, APD)

#### Features

- ◆ 10Gb/s Serial Optical Interface
  - High quality and reliability optical device and sub-assemblies
  - Cooled EA-DFB laser for up to 80km over Single Mode Fiber
  - High sensitivity APD and linear TIA
- ◆ SFP+ MSA Compliant
  - Easy supply management for hot pluggability
  - Duplex LC Receptacle
  - SFP Mechanical Interface for easy removal
  - SFI High Speed Electrical Interface
  - 2-wire interface for management and diagnostic monitor
  - Tx\_Disable and Rx\_LOS functions
- ◆ Protocol
  - IEEE802.3ae 10Gigabit Ethernet LAN PHY/WAN PHY
  - OTU2 and OTU2e
- ◆ Power Supply
  - Single 3.3V power supply
  - Max 1.6W power consumption
- ◆ RoHS6 compliant



#### Applications

- ◆ 10GE Ethernet switches and routers
- ◆ 10GE Storage
- ◆ Other high speed data connections

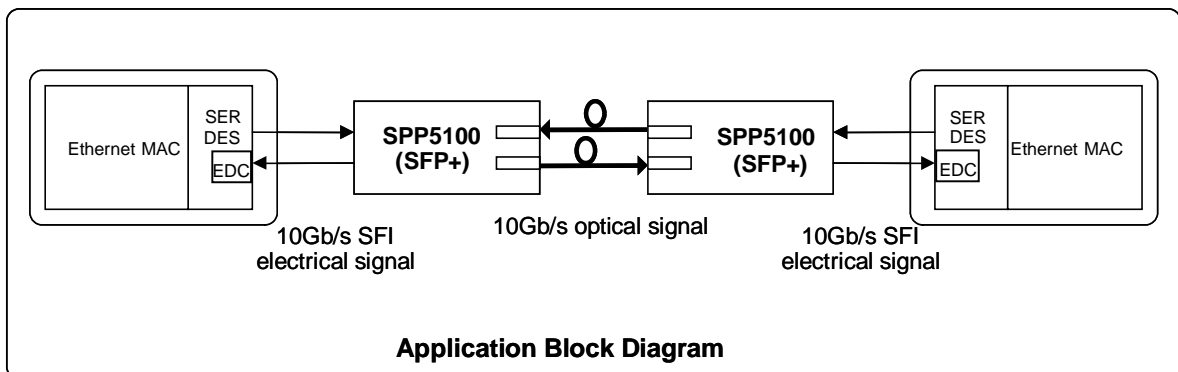

## 1. General Description

The SPP5100ZR-GL is a very compact 10Gb/s optical transceiver module for serial optical communication applications at 10Gb/s. The SPP5100ZR-GL converts a 10Gb/s serial electrical data stream to 10Gb/s optical output signal and a 10Gb/s optical input signal to 10Gb/s serial electrical data streams. The high speed 10Gb/s electrical interface is fully compliant with SFI specification of SFF-8431.

The SPP5100ZR-GL is designed for Ethernet LAN (10.3Gb/s) and WAN(9.95Gb/s) applications. The high performance cooled EA-DFB-LD transmitter and high sensitivity and low noise APD receiver provide superior performance for multi-rate applications at up to 80km links.

The fully SFP compliant form factor provides hot pluggability, easy optical port upgrades and low EMI emission.

**Table 1.1 Fiber compliance**

SFP+ type	Wavelength [nm]	Cable Type	Core Size (micron)	Cable distance
10GB-ZR	1550	SMF	G.652	80km

## 2. Functional Description

The SPP5100ZR-GL contains a duplex LC connector for the optical interface and a 20-pin connector for the electrical interface. Figure 2.1 shows the functional block diagram of SPP5100ZR-GL SFP Transceiver.

### Transmitter Operation

The transceiver module receives 10Gb/s electrical data and transmits the data as an optical signal.

The transmitter output can be turned off by Tx disable signal, TX\_DIS pin. When TX\_DIS is asserted High, Transmitter is turned off.

### Receiver Operation

The received optical signal is converted to serial electrical data signal.

The RX\_LOS signal indicates insufficient optical power for reliable signal reception at the receiver.

### Management Interface

A 2-wire interface (SCL, SDA) is used for serial ID, digital diagnostics and other control /monitor functions.

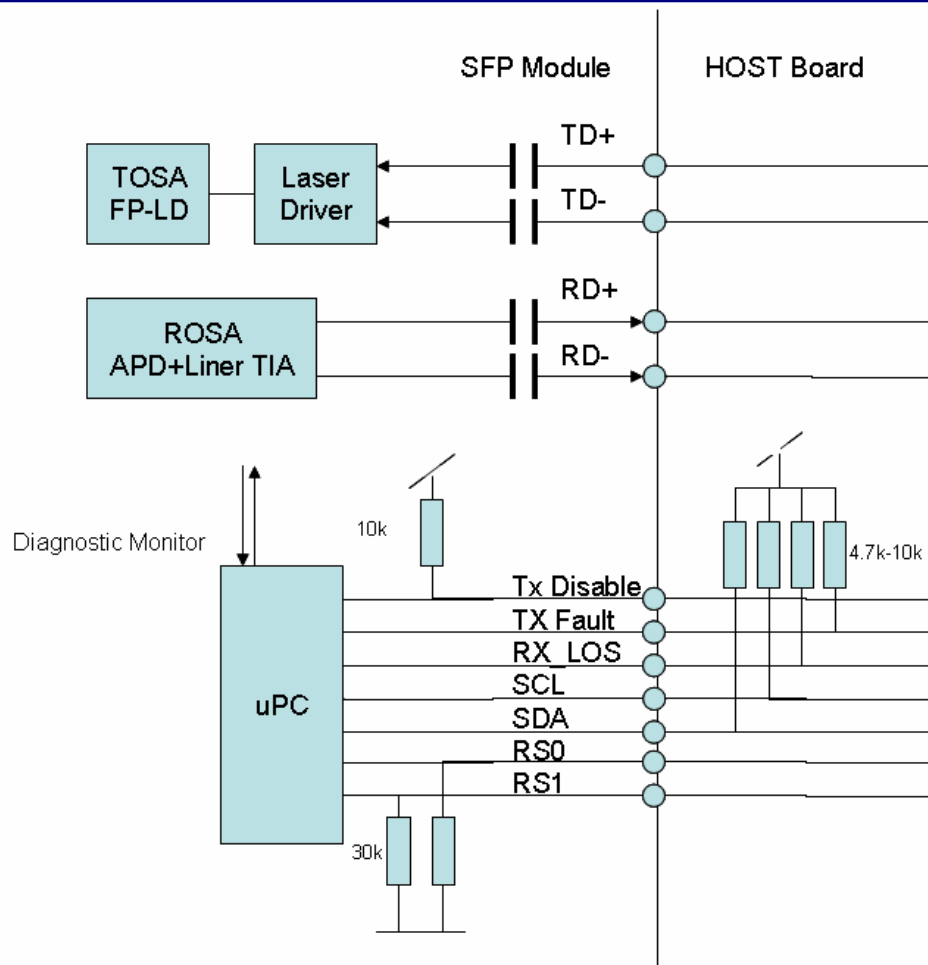

Figure 2.1 Functional Block Diagram

### 3. Package Dimensions

Figure 3.1. shows the package dimensions of SPP5100ZR-GL. SPP5100ZR-GL is designed to be compliant with SFP MSA specification. Package dimensions are specified in SFF-8432. (Note : Drawing below will be revised in the future./Bail color :**GREEN**)

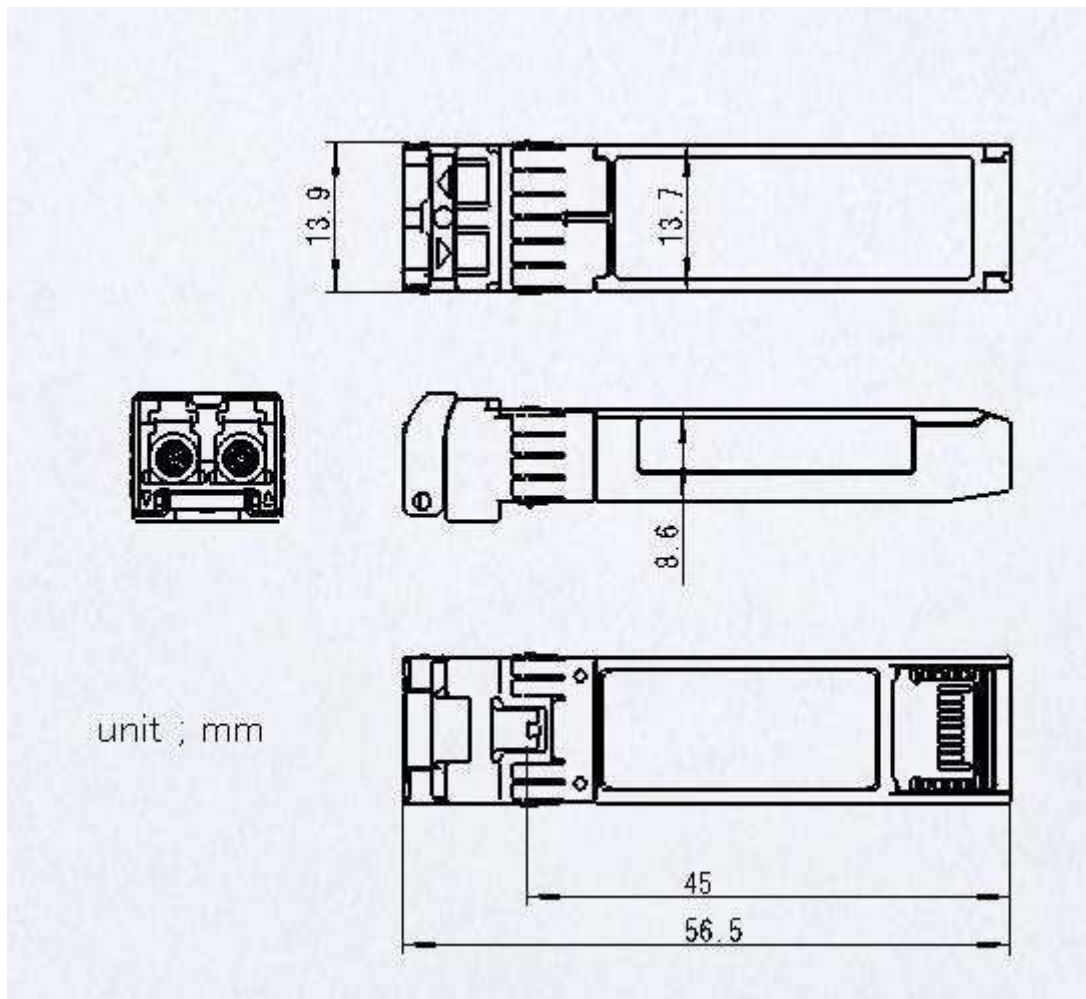

Figure 3.1 Package dimensions

## 4. Pin Assignment and Pin Description

### 4.1. SFP Transceiver Electrical Pad Layout

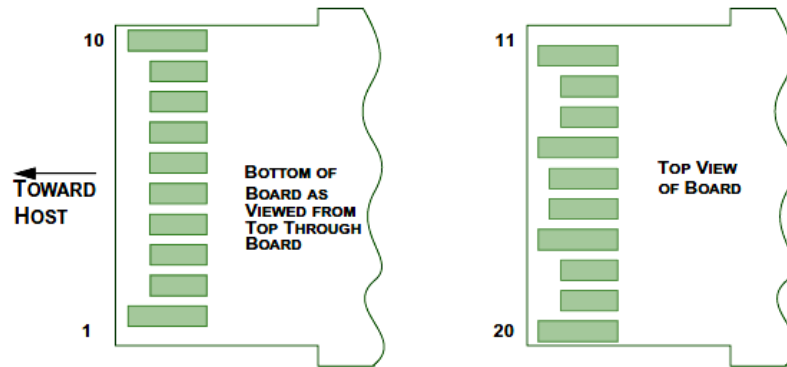

Figure 4.1.1 SFP Transceiver Electrical Pad Layout

### 4.2. Host PCB SFP Pinout

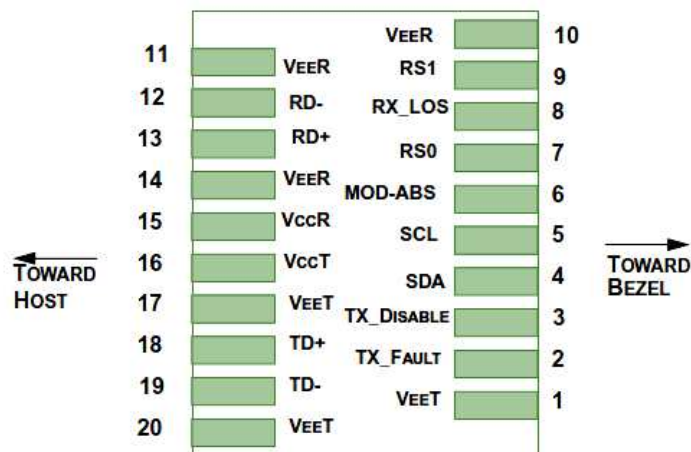

Figure 4.2.1 Host PCB SFP Pinout

### 4.3. Pin Descriptions

Table 4.3.1 Pin Description

Pin#	Name	Logic	Description	Power Sequence Order	Note
1	VeeT		Module Transmitter Ground	1 <sup>st</sup>	1
2	Tx_Fault	LVTTL-O	Module Transmitter Fault	3 <sup>rd</sup>	2
3	Tx_Disable	LVTTL-I	Transmitter Disable, Turns off transmitter laser output	3 <sup>rd</sup>	3
4	SDA	LVTTL-I/O	2 Wire Serial Interface Data Line	3 <sup>rd</sup>	
5	SCL	LVTTL-I/O	2 Wire Serial Interface Data Line	3 <sup>rd</sup>	
6	MOD_ABS		Module Absent, connected to VeeT or VeeR in the module	3 <sup>rd</sup>	2
7	RS0	LVTTL-I	Rate Select 0 (not functional for 10GE type)	3 <sup>rd</sup>	
8	RX_LOS	LVTTL-O	Receiver Loss of Signal Indication	3 <sup>rd</sup>	2
9	RS1	LVTTL-I	Rate Select 1 (not functional for 10GE type)	3 <sup>rd</sup>	
10	VeeR		Module Receiver Ground	1 <sup>st</sup>	1
11	VeeR		Module Receiver Ground	1 <sup>st</sup>	1
12	RD-	CML-O	Receiver Inverted Data Output	3 <sup>rd</sup>	
13	RD+	CML-O	Receiver Non-Inverted Data Output	3 <sup>rd</sup>	
14	VeeR		Module Receiver Ground	1 <sup>st</sup>	1
15	VccR		Module Receiver 3.3V Supply	2 <sup>nd</sup>	
16	VccT		Module Transmitter 3.3V Supply	2 <sup>nd</sup>	
17	VeeT		Module Transmitter Ground	1 <sup>st</sup>	1
18	TD+	CML-I	Transmitter Non-Inverted Data Input	3 <sup>rd</sup>	
19	TD-	CML-I	Transmitter Inverted Data Input	3 <sup>rd</sup>	
20	VeeT		Module Transmitter Ground	1 <sup>st</sup>	1

Note

- 1: Module ground pins are isolated from the module case and chassis ground within the module.
- 2: Shall be pulled up with 4.7k to 10k ohm to a voltage between 3.15V and 3.45V on the host board.
- 3: Shall be pulled up with 4.7k to 10k ohm to VccT in the module.

## 5. Absolute Maximum Ratings and Recommended Operating Conditions

Table 5.1 Absolute Maximum Ratings

Parameter	Symbol	Min	Max	Unit	Note
Storage Temperature	Tst	-40	85	degC	
Relative Humidity (non-condensation)	RH	-	85	%	
Supply Voltage	VccR/VccT	-0.5	3.6	V	
Voltage on LVTTTL Input	Vilvttl	-0.5	VCC3+0.5	V	
LVTTTL Output Current	Iolvttl	-	15	mA	
Voltage on Open Collector Output	Voco	0	6	V	
Receiver Input Optical Power(Average)	Mip	-	5	dBm	

Table 5.2 Recommended Operating Conditions and Supply Requirements

Parameter	Symbol	Min	Max	Unit	Note
Operating Case Temperature	Topc	0	70	degC	
Relative Humidity(non-condensing)	Rhop	-	85	%	
Power Supply Voltage	VccR/VccT	3.135	3.465	V	
Total Power Consumption	Pd	-	1.6	W	1

Note:

1: The inrush current meets SFF-8431 level-II operation.

## 6. Electrical Interface

### 6.1. High Speed Electrical Interface

#### SFI Application Reference model

Figure 6.1.1. shows the high speed electrical interface (SFI) compliance points.

SFI electrical interface is specified for each compliance point in the SFP MSA specification.

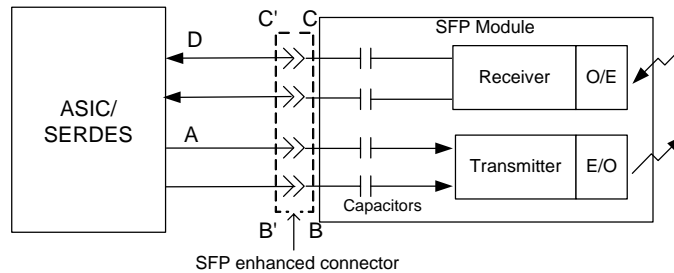

**Figure 6.1.1 SFI Application Reference Model**

#### SFI Module Transmitter Input Electrical Interface Specification at B' and Calibrated B''

**Table 6.1.1 SFI Transmitter Input Electrical Specification at B'**

Parameter B'	Symbol	Condition	Min	Typ.	Max.	Unit
Single Ended Output Voltage Tolerance		Referenced to VeeT	-0.3		4.0	V
AC common Input S-parameter		Note 1	15			mV
Differential Input S-parameter (note 1)	SDD11	0.01-4.1GHz			Note 2	dB
		4.1-11.1GHz			Note 3	dB
Reflected Differential to Common Mode Conversion	SCD11	0.01-11.1GHz			-10	dB

Note 1. Measured at B'' with Host Compliance Board and Module Compliance Board pair.

2. Maximum Reflection Coefficient given by equation  $SDD11(dB) = -12 + 2 * \sqrt{f}$ , with f in GHz.

3. Maximum Reflection Coefficient given by equation  $SDD11(dB) = -6.3 + 13 \log_{10}(f/5.5)$ , with f in GHz

**Table 6.1.2 SFI Transmitter Input Electrical Specification at B''**

Parameter B''	Symbol	Condition	Min	Typ.	Max.	Unit
Crosstalk Source Rise/Fall time (20% to 80%)	Tr, Tf	Note 1, 2		34		ps
Crosstalk Source Amplitude (p-p differential)		Note 1, 2		1000		mV
AC Common Mode Voltage		Note 3			15	mV(RMS)
Total Jitter	TJ				0.28	UIpp
Data Dependant Jitter	DDJ			0.10		UIpp
Pulse Width Shrinkage Jitter	DDPWS			0.055		UIpp
Uncorrelated Jitter	UJ	Note 4		0.023		UIrms
Eye Mask Figure 6.1.2	X1		0.12			UI
	X2		0.33			UI
	Y1		95			mV
	Y2		350			mV

- Note 1. Measured at C'' with Host Compliance Board and Module Compliance Board pair.
2. Since the minimum module output transition time is faster than the crosstalk transition time the amplitude of crosstalk source is increased to achieve the same slew rate.
3. The tester is not expected to generate this common mode voltage however its output must not exceed this value.
4. It is not possible to have the worst UJ and DDJ simultaneously and meet the TJ specifications if the UJ is all Gaussian.

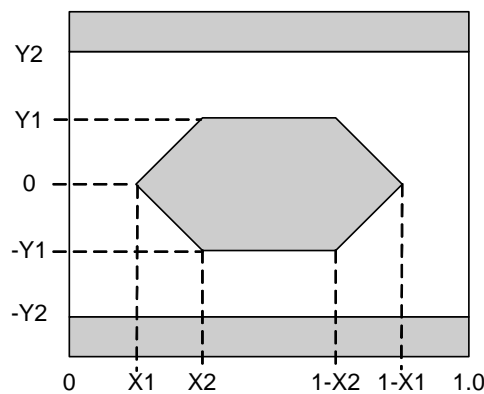

**Figure 6.1.2 Transmitter Input Eye Mask**

**SFI Module Receiver Output Electrical Interface Specification at C'**

**Table 6.1.3 SFI Receiver Output Electrical Specification at C'**

Parameter – C'	Symbol	Conditions	Min	Typ	Max	Units
Crosstalk source rise/fall time (20% to 80%)	Tr, Tf	Note 1		34		ps
Crosstalk Source Amplitude Differential (p-p)		Note 2		700		mV
Termination Mismatch at 1 MHz	$\Delta Z_M$				5	%
Single Ended Output Voltage Tolerance			-0.3		4.0	V
Output AC Common Mode Voltage					7.5	mV (RMS)
Differential Output S-parameter (Note 3)	SDD22	0.01-4.1GHz			Note 2	dB
		4.1-11.1GHz			Note 3	dB
Common Mode Output Reflection Coefficient (Note 5)	SCC22	0.01-2.5GHz			Note 4	dB
		2.5-11.1GHz			-3	dB

Note 1 : Measured at B" with the Host Compliance Board and Module Compliance Board pair.

2 : Reflection Coefficient given by equation  $SDD22(dB) < -12 + 2 \times \text{SQRT}(f)$ , with f in GHz.

3 : Reflection Coefficient given by equation  $SDD22(dB) < -6.3 + 13 \times \log_{10}(f/5.5)$ , with f in GHz.

4 : Reflection coefficient given by equation  $SCC22(dB) < -7 + 1.6 \times f$ , with f in GHz.

**Table 6.1.4 SFP+ Linear Output Jitter and Eye Mask Specification at C'**

Parameter – C'	Symbol	Condition	RN				
			m1	b1	m2	b2	RN <sub>max</sub>
Relative Noise with pre-cursor stressor	RN		-0.0153	0.0475	-0.0092	0.0457	0.0475
Relative Noise with split-symmetrical stressor			-0.017	0.0475	-0.01	0.0455	0.0475
Relative Noise with post-cursor stressor			-0.0153	0.0475	-0.0092	0.0457	0.0475
Parameter – C'	Symbol	Condition		Min		Max	Units
Difference Waveform Distortion Penalty	dWDP	Note 1				1.5	dB
Differential Voltage Modulation Amplitude	VMA			180		600	mV
Differential peak to peak voltage	Vpk-pk					600	mA

Note 1 : Defined with reference receiver with 14 T/2 spaced FFE taps and 5 T spaced DFE taps.

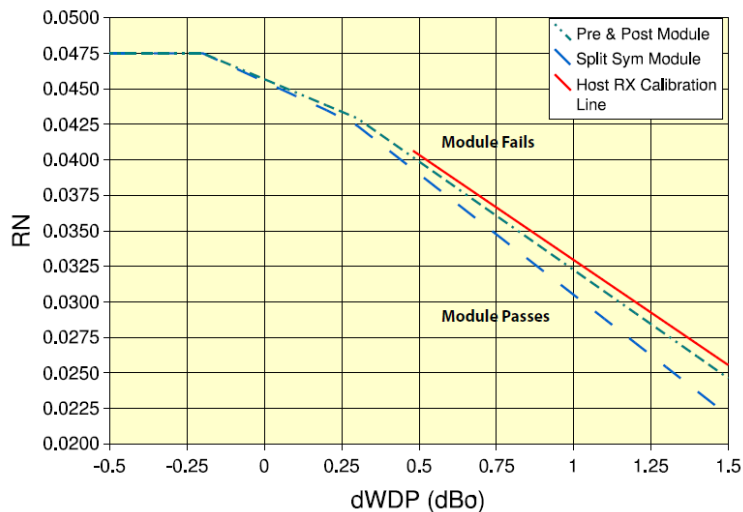

**Figure 6.1.3 RN and dWDP compliance regions**

## 6.2. Low speed Electrical Interface

SPP5100ZR-GL low speed interface is based on 2-wire interface. Management memory map is based on SFF-8472.

### 2-wire Electrical Specifications

Parameter	Symbol	Min	Max	Unit
Host 2-wire Vcc	Vcc_host	3.14	3.46	V
SCL and SDA	V <sub>OL</sub>	0.0	0.40	V
	V <sub>OH</sub>	Vcc_host-0.5	Vcc_host+0.3	V
SCL and SDA	V <sub>IL</sub>	-0.3	VccT*0.3	V
	V <sub>IH</sub>	VccT*0.7	VccT+0.5	V
Input current on the SCL and SDA contacts		-10	10	uA
Capacitance on SCL and SDA I/O contact			14	pF

### 2-wire Timing Specifications

Parameter	Symbol	Min	Max	Unit
Clock Frequency	f <sub>SCL</sub>	0	400	kHz
Clock Pulse Width Low	t <sub>LOW</sub>	1.3		us
Clock Pulse Width High	t <sub>HIGH</sub>	0.6		us
Time bus free before new transmission can start	t <sub>BUF</sub>	20		us
START Hold Time	t <sub>HD, STA</sub>	0.6		us
START Set-up Time	t <sub>SU, STA</sub>	0.6		us
Data In Hold Time	t <sub>HD, DAT</sub>	0		us
Data In Set-up Time	t <sub>SU, DAT</sub>	0.1		us
Input Rise Time (100kHz)	t <sub>r, 100</sub>		1000	ns
Input Rise Time (400kHz)	t <sub>r, 400</sub>		300	ns
Input Fall Time (100kHz)	t <sub>f, 100</sub>		300	ns
Input Fall Time (400kHz)	t <sub>f, 400</sub>		300	ns
STOP Set-up Time	t <sub>SU, STO</sub>	0.6		us
Serial Interface Clock Holdoff “Clock Stretching”	t <sub>clock_hold</sub>		500	us

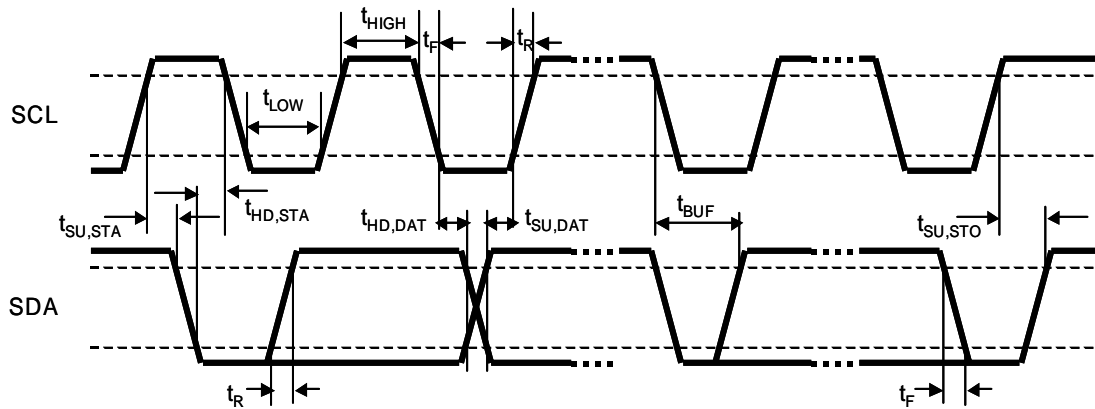

Figure 6.2.1 SFP+ Timing Diagram

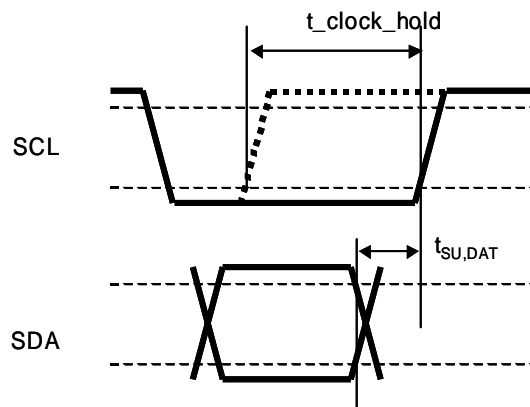

Figure 6.2.2 Detail of Clock Stretching

## 7. Optical Interface

Optical Interfaces of SPP5100ZR-GL are defined as follows.

### 7.1. Optical Transmitter

**Table 7.1.1 Optical Transmitter Specifications**

Parameter	Symbol	Min	Typ	Max	Unit
Signaling Speed (WAN PHY)		-	9.95328		Gb/s
(LAN PHY)			10.3125		
Signaling speed variation from nominal (max) for 10GE-LAN		-100		+100	ppm
Signaling speed variation from nominal (max) for 10GE-WAN		-20		+20	ppm
Center wavelength (Note 1)		1530		1565	nm
Spectral Width	$\Delta\lambda$	-		1	nm
Side Mode Suppression Ratio	SMSR	30			dB
Average launched power	Pave	0		+4.0	dBm
Average launch power of Tx OFF	Pave_off			-30	dBm
Extinction ratio (Note 2)	ER	8.2			dB
Eye mask (X1,X2,X3,Y1,Y2,Y3)		(0.25, 0.40, 0.45, 0.25, 0.28, 0.40) (Note 1)			

Note 1 : Refer to Figure 7.1.

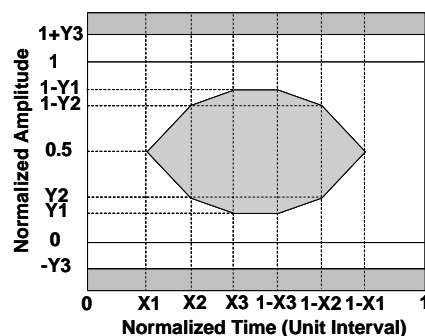

**Figure.7.1 Transmission eye mask definition**

## 7.2. Optical Receiver

**Table 7.2.1 Optical Receiver Specifications**

Parameter	Symbol	Min	Typ	Max	Unit
Wavelength (Note 1)		1260		1565	nm
Receiver Reflectance				-27	dB
Receiver Damage Threshold				+5	dBm
<b>NO FEC APPLICATION</b>					
Receiver Sensitivity @BER=1E-12 with PRBS31 and 10GE frame				-24	dBm
Chromatic Dispersion (CD) Penalty @1600ps/nm (Note 2)				3.0	dB
Receiver Overload		-7			dBm

Note 1 : Receiver Sensitivity specified over 1528-1565 nm only, with 3dB degradation permitted from 1260-1528nm.

Note 2 : A max 3 dB of power penalty on every TX-RX optical SFP+ pair shall be guaranteed.

## 7.3. Jitter Specification

### **10GE LAN**

10GE LAN shall comply with the appropriate 10Gb/s Ethernet jitter requirements. In Ethernet the jitter requirements are rolled into the eye mask so that in practice all that is required is compliance with the appropriate 10Gb/s Ethernet eye mask

### **10GE WAN**

10GE WAN shall comply with the SONET/SDH jitter requirement according to ITU G.8251 and ITU G.783, Telcordia GR-253 issue 4, and ANSI T1.105.03. Jitter generation methodology is defined in chapter 5.4; jitter transfer and tolerance are for further study.

## 8. Electrical and Optical I/O Signal Relationship

Table.8.1 TX\_DIS vs. Optical Output Power

TX_DIS	Optical Output Power
Low ( $V_{IL} = -0.3$ to $0.8V$ )	Enabled
High ( $V_{IH} = 2.0$ to $VCC3+0.3V$ )	Disabled ( $<-30dBm$ )

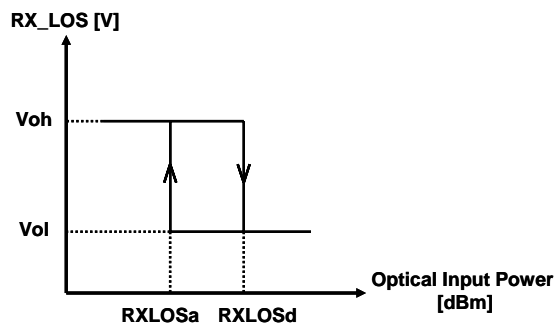

Figure.8.1 Optical Input Power vs. RX\_LOS

## 9. User Interface

### 9.1. SFP Mechanical Interface

SFP Mechanical Interface is specified in the SFF-8432. Also, bail latch system is adequate for the particular specification.

### 9.2. Management Interface

#### SFP 2-Wire Serial Interface Protocol

SFP 2-wire serial interface is specified in the SFF-8472.

The SFP 2-wire serial interface is used for serial ID, digital diagnostics, and certain control functions. The 2-wire serial interface is mandatory for all SFP modules.

The 2-wire serial interface address of the SFP module is A0h and A2h. In order to access to a specific module on the 2-wire serial bus, the SFP has a MOD\_ABS (module absent pin). This pin, which is pulled down in the module, must be held low to notify a module installation and to allow communication over 2-wire serial interface.

#### SFP Management Interface

SFP Managed interface is specified in the SFF-8472.

The Figure 9.2. shows the structure of the memory map. The normal 256 Byte address space is divided into lower and upper blocks of 128 Bytes. The lower block of 128 Byte is always directly

available and is used for the diagnostics and control functions that must be accessed repeatedly. Multiple blocks of memories are available in the upper 128 Bytes of the address space. These are individually addressed through a table select Byte which the user enters into a location in the lower address space. The upper address space tables are used for less frequently accessed functions and control space for future standards definition.

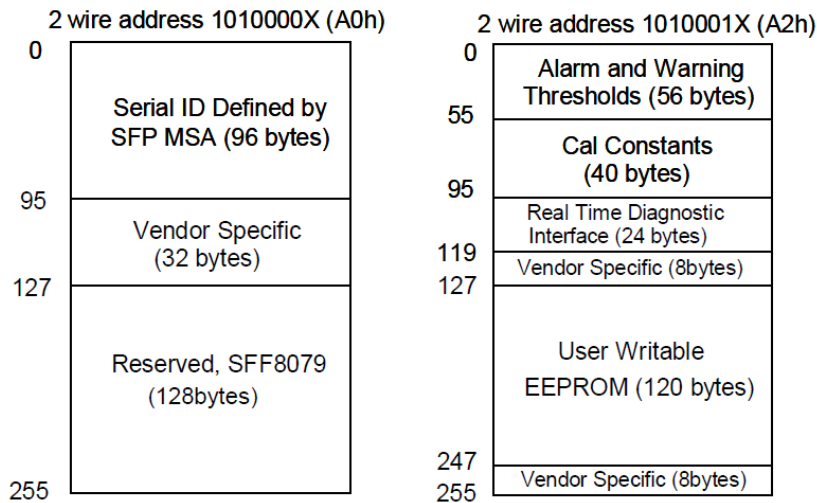

Figure 9.1 2-wire Serial Interface Memory Map

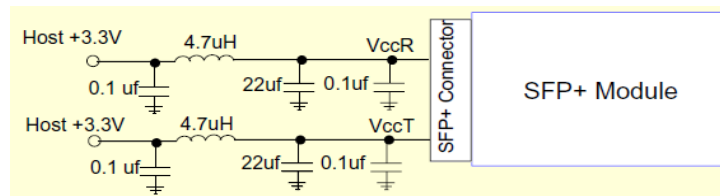

Figure 9.2 Supply Filter

### 9.3. Serial ID Memory Map (Data Field – Address A0h)

Address	Size (Bytes)	Name	Hex	ASC	Description	Address	Size (Bytes)	Name	Hex	ASC	Description			
0	1	Identifier	03		SFP module	64	2	Options	05		Cooled Transceiver			
1	1	Ext.Identifier	04		Serial ID module				1A	Linear Receiver Output				
2	1	Connector	07		LC Connector	65					TxDisable, TxFault, LOS implemented			
3	8	Transceiver	00		Unallocated									
4			00											
5			00				66	1	BR,max	00				
6			00				67	1	BR,min	00				
7			00				68	16	Vendor SN	xx				
8			00				69			xx				
9			00				70			xx				
10			00				71			xx				
11	1	Encoding	06		64B66B	72	xx							
12	1	BR, Nominal	67		10.3Gbps	73	xx							
13	1	Rate Identifier	00		unspecified	74	xx							
14	1	Length(9um, km)	50		80km	75	xx							
15	1	Length(9um)	FF		> 25.5km	76	xx							
16	1	Length(50um)	00		not support MMF	77	xx							
17	1	Length(62.5um)	00		not support MMF	78	xx							
18	1	Length(Copper)	00		not support copper	79	20							
19	1	Length(OM3)	00		not support MMF	80	20							
20	16	Vendor name	53	S		81	20							
21			75	u			82			20				
22			6D	m			83			20				
23			69	i			84	xx				Year code		
24			74	t			85	xx						
25			6F	o			86	xx				Month code		
26			6D	m			87	xx						
27			6F	o			88	xx				Day code		
28			45	E			89	xx						
29			6C	l			90	xx				LOT code		
30			65	e			91	xx						
31			63	c			92	1	Diagnostis Monitoring Type	68			Internal cal , Average Power	
32			74	t			93	1	Enhanced Options	F0			Alarm/Warning flags, Soft TxDisable, Soft TxFault, Soft RxLOS implemented	
33			72	r			94	1	SFF-8472 Compliance	04			Rev.10.4	
34			69	i			95	1	CC_EXT	xx			Check Code *3	
35			63	c			96-127	32	Vendor Specific	xx				
36	1	Channel Spacing	00		128-255	125	Reserved	00						
37	3	Vendor OUI	00											
38			00											
39			5F											
40	16	Vendor PN	53	S										
41			50	P										
42			50	P										
43			35	S										
44			31	1										
45			30	0										
46			30	0										
47			5A	Z										
48			52	R										
49			2D	-										
50			47	G										
51			4C	L										
52			20											
53			20											
54			20											
55			20											
56	4	Vendor rev	41 to 5A	A to Z	*1									
57			20											
58			20											
59			20											
60	2	Wavelength	06		1550nm									
61			0E											
62	1		00											
63	1	CC_BASE	xx		Check Code *2									

\*1 : Revision level for part number provided by vendor (ASCII). Variable  
 \*2 : Checksum of Add.0 to 62  
 \*3 : Checksum of Add.64 to 94

#### 9.4. Alarm/Warming threshold

A2h address	Meaning	Unit	SPP5100ZR-GL
0-1	Temperature High Alarm	deg	75
2-3	Temperature Low Alarm	deg	-5
4-5	Temperature High Warning	deg	70
6-7	Temperature Low Warning	deg	0
8-9	Voltage High Alarm	V	3.63
10-11	Voltage Low Alarm	V	2.97
12-13	Voltage High Warning	V	3.465
14-15	Voltage Low Warning	V	3.135
16-17	Tx Bias High Alarm	mA	TBD
18-19	Tx Bias Low Alarm	mA	
20-21	Tx Bias High Warning	mA	
22-23	Tx Bias Low Warning	mA	
24-25	Tx Power High Alarm	dBm	7.0
26-27	Tx Power Low Alarm	dBm	-4.0
28-29	Tx Power High Warning	dBm	4.0
30-31	Tx Power Low Warning	dBm	0.0
32-33	Rx Power High Alarm	dBm	-3.0
34-35	Rx Power Low Alarm	dBm	-31.0
36-37	Rx Power High Warning	dBm	-7.0
38-39	Rx Power Low Warning	dBm	-27.0

Note. Alarm /Warming flag is linked to TxFault by default setting.

#### 9.5. Digital Diagnostic Monitor Accuracy

The following characteristics are defined over recommended operating conditions.

Parameter	Accuracy	Unit
Internally measured transceiver temperature	+/- 3	deg.C
Internally measured transceiver supply voltage	+/- 3	%
Measured Tx bias current	+/- 10	%
Measured Tx output power	+/- 2	dB
Measured Rx received average optical power	+/- 3	dB

## 10. RoHS COMPLIANCY

Compliance versus requirements contained inside the following reference document is guaranteed: "Directive 2002/95/EC of 27 January 2003 on the restriction of the use of certain hazardous substances in electrical and electronic equipment" from official journal of European Union (European Parliament and of the Council). This product is Compliant at RoHS-6/6 level and contains no leaded solders.

## 11. Qualification Testing

SPP5100ZR-GL 10Gb/s transceiver is qualified to Sumitomo Electric Industries internal design and manufacturing standards. Telecordia GR-468-CORE reliability test standards, using methods per MIL-STD-883 for mechanical integrity, endurance, moisture, flammability and ESD thresholds, are followed.

## 12. Laser Safety Information

SPP5100ZR-GL transceiver uses a semiconductor laser system that is classified as Class 1 laser products per the Laser Safety requirements of FDA/CDRH, 21 CFR1040.10 and 1040.11. These products have also been tested and certified as Class 1 laser products per IEC 60825-1:2007 and IEC60825-1:2001 International standards.

### **Caution**

---

If this product is used under conditions not recommended in the specification or is used with unauthorized revision, the classification for laser product safety is invalid. Reclassify the product at your responsibility and take appropriate safety measures.

---

## 13. Electromagnetic Compatibility

### **EMI (Emission)**

SPP5100ZR-GL is designed to meet FCC Class B limits for emissions and noise immunity per CENELEC EN50 081 and 082 specifications.

### **RF Immunity**

SPP5100ZR-GL has an immunity to operate when tested in accordance with IEC 61000-4-3 (80- 1000MHz, Test Level 3) and GR-1089.

**Electrostatic Discharge (ESD) Immunity**

SPP5100ZR-GL has an immunity against direct and indirect ESD when tested accordance with IEC 61000-4-2.

**14. Firmware version**

**15. Ordering Information**

**15.1. Part Numbering System**

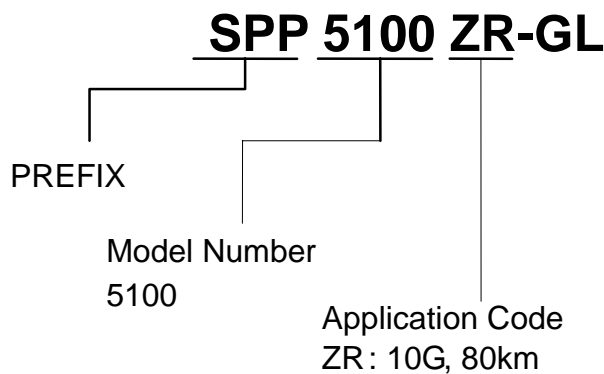

**15.2. Ordering Number Code**

Table 15.1 SPP5100ZR Application Code

Part Number	Temperature Range	Distance	Fiber	E/O	O/E	IEEE
SPP5100ZR-GL	0 to 70 deg.C	80km	SMF	Cooled EA-DFB 1550nm	APD	802.3ae

**16. Label information**

(Top label)



(Case Label)



## 17. Contact Information

### U.S.A.

#### Sumitomo Electric Device Innovations, U.S.A., Inc.

<West Coast (USA Headquarters)>

2355 Zanker Rd. San Jose, CA 95131-1138, USA

Tel: +1-408-232-9500

Fax: +1-408-428-9111

<East Coast>

4021 Stirrup Creek Drive, Suite 200, Durham, NC 27703, USA

Tel: +1-919-361-1600

Fax: +1-919-361-1619

Email: [lw-info@sei-device.com](mailto:lw-info@sei-device.com), [mw-info@sei-device.com](mailto:mw-info@sei-device.com)

<http://www.sei-device.com/>

### Europe

#### Sumitomo Electric Europe Ltd.

220 Centennial Park, Elstree, Herts, WD6 3SL UK

Tel: +44-208-953-8681

Fax: +44-208-207-5950

E-mail: [photonics@sumielectric.com](mailto:photonics@sumielectric.com)

<http://www.sumielectric.com>

### Asia

#### Sumitomo Electric Asia Ltd.

Photonics Department

Room 2624 - 2637, 26F., Sun Hung Kai Center, 30 Harbour Road, Wanchai, Hongkong.

Tel: +852-2576-0080

Fax: +852-2576-6412

### Japan

#### Sumitomo Electric Industries, Ltd.

Device Sales Department

<Tokyo>

3-9-1, Shibaura, Minato-ku, Tokyo 108-8539, Japan

TEL +81-3-6722-3286

FAX +81-3-6722-3284

<Osaka>

4-5-33, Kitahama, Chuo-ku, Osaka 541-0041, Japan

Tel: +81-6-6220-4245

Fax: +81-6-6222-6231

E-mail: [optoele-sales-pro-sml@list.sei.jp](mailto:optoele-sales-pro-sml@list.sei.jp)

<http://www.sei.co.jp/products/index.html>