

Features

- ▶ Digital signal processing
- ▶ On chip supply shunt regulator
- ▶ Low power consumption
- ▶ Differential PIR sensor input
- ▶ Excellent power supply rejection
- ▶ Insensitive to RF interference
- ▶ Inputs for sensitivity, on time and daylight sensor
- ▶ Outputs for relay and LED
- ▶ Instantaneous settling after power up

Applications

- ▶ PIR motion detection
- ▶ Intruder detection
- ▶ Occupancy detection
- ▶ Motion sensor lights

General Description

The E931.97 integrated circuit combines all required functions for a single chip Passive Infra Red (PIR) motion detector. Motion detection is signaled through the push-pull REL output. A digital input OEN enables REL output. A LED output indicates whenever the PIR Signal is above the selected threshold. The E931.97 interfaces directly to up to two conventional PIR sensors via a high impedance differential input. The PIR signal is converted to a 15 bit digital value on chip. The parameters for sensitivity and timing are set by connecting the corresponding inputs to DC voltages. The voltage levels on the inputs are converted to digital values with 7 bit resolution. All signal processing is performed digitally.

Ordering Information

Product ID	Temp. Range	Package
E931.97	-25°C to +85°C	TSSOP14/ SOIC14

Application Circuit For Wired Intruder Detector

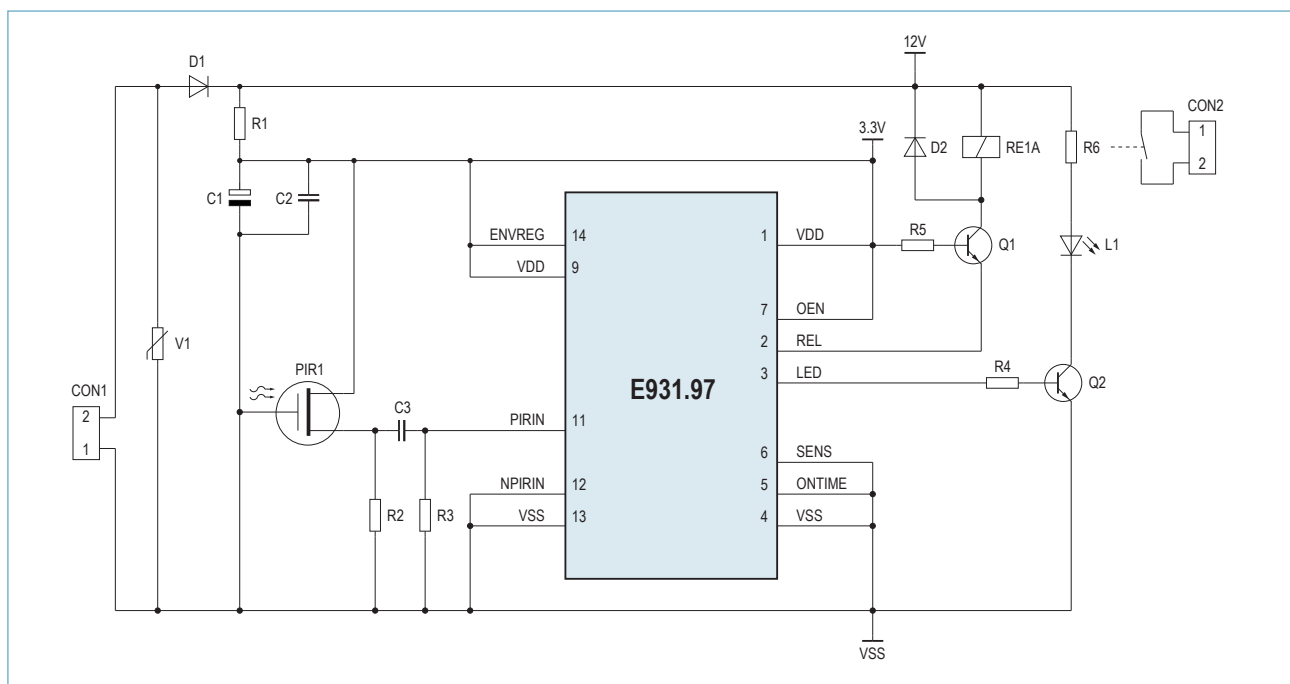

This document contains information on a product under development. ELMOS Semiconductor AG reserves the right to change or discontinue this product without notice.

ELMOS Semiconductor AG – Headquarters
Heinrich-Hertz-Str. 1 | 44227 Dortmund | Germany
Phone +49 (0) 231-75 49-100 | Fax +49 (0) 231-75 49-159
sales@elmos.de | www.elmos.de

Note ELMOS Semiconductor AG (below ELMOS) reserves the right to make changes to the product contained in this publication without notice. ELMOS assumes no responsibility for the use of any circuits described herein, conveys no licence under any patent or other right, and makes no representation that the circuits are free of patent infringement. While the information in this publication has been checked, no responsibility, however, is assumed for inaccuracies. ELMOS does not recommend the use of any of its products in life support applications where the failure or malfunction of the product can reasonably be expected to cause failure of a life-support system or to significantly affect its safety or effectiveness. Products are not authorized for use in such applications.

Copyright © 2010 ELMOS. Reproduction, in part or whole, without the prior written consent of ELMOS, is prohibited.