



# FPI-W MPI-W

## MINIBRIDGE<sup>®</sup> 40/50 AMPERES BRIDGE RECTIFIERS WIRE LEADS FOR PC BOARDS



← INTEGRALLY MOLDED  
HEAT SINKS  
PROVIDE VERY LOW  
THERMAL RESISTANCE



This mark indicates recognition under the component program of Underwriters Laboratories, inc.

### ELECTRICAL CHARACTERISTICS PER LEG (at $T_A = 25^\circ\text{C}$ Unless Otherwise Specified)

### SERIES DESIGNATIONS (See Figure 1)

	FPI40-W	MPI40-W	MPI50-W	UNITS
Average Forward Current, $I_F(\text{Av.})$ TC $55^\circ\text{C}$ See Figure 3	40	40	50	Amps
Max. Peak Surge Current, $I_{FSM}$ (8.3ms) See Figure 2	300	400	400	Amps
Max. Instantaneous Forward Voltage Drop, $V_F = 1.2\text{V}$ @ $I_F = \text{Pulse}$ T est: Pulse Width $< 300 \mu\text{s}$ . Duty cycle $< 2.0\%$	20	35	45	Amps
Max. D.C. Reverse Current @ PRV and $25^\circ\text{C}$ , $I_R$	10	10	10	$\mu\text{A}$
Max. D.C. Reverse Current @ PRV and $100^\circ\text{C}$ , $I_R$	100	100	100	$\mu\text{A}$
Thermal Resistance, Total Bridge $R_{\theta j-c}$	1.2typ.			$^\circ\text{C}/\text{W}$
Storage Temperature Range, $T_{STG}$	-55 to +175			$^\circ\text{C}$

EDI reserves the right to change these specifications at any time without notice.

# FPI-W MPI-W

Figure 1  
PART NUMBER NOMENCLATURE  
PEAK REVERSE VOLTAGE (PRV/LEG)

AVERAGE FORWARD CURRENT RATING (AMPERES)

	50 VOLTS	100 VOLTS	200 VOLTS	400 VOLTS	600 VOLTS	800 VOLTS	1000 VOLTS
40AMPS	FPI4005W	FPI4010W	FPI4020W	FPI4040W	FPI4060W	FPI4080W	FPI40100W
40AMPS	MPI4005W	MPI4010W	MPI4020W	MPI4040W	MPI4060W	MPI4080W	MPI40100W
50AMPS	MPI5005W	MPI5010W	MPI5020W	MPI5040W	MPI5060W	MPI5080W	MPI50100W

Figure 2  
NON-REPETITIVE SURGE CURRENT

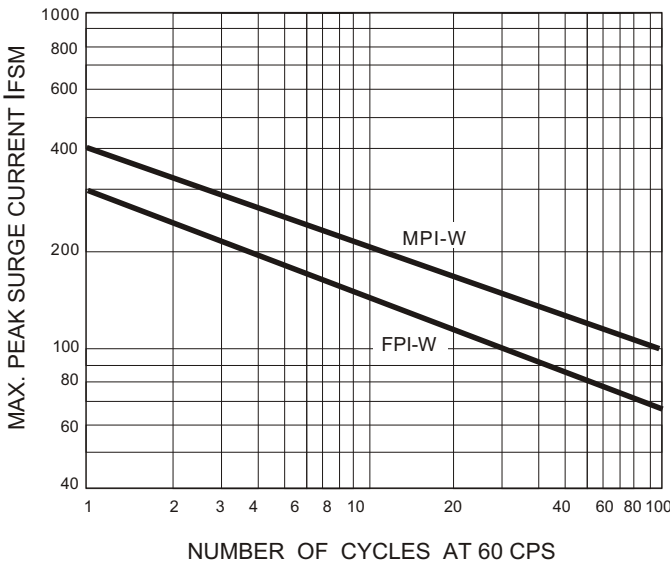
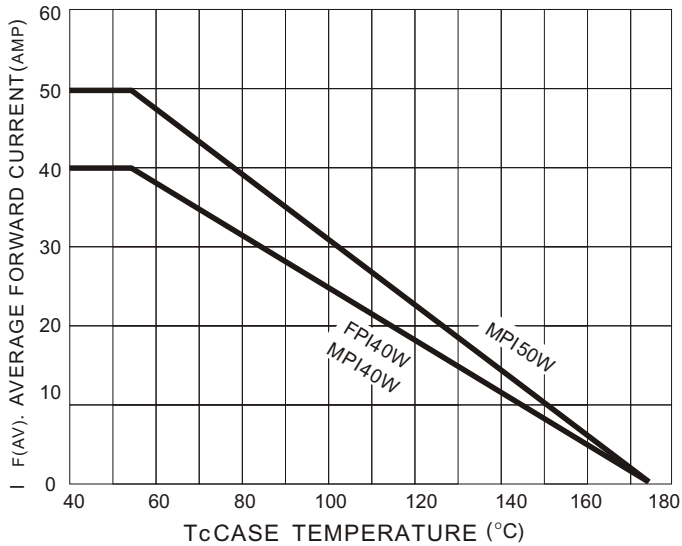

Figure 3  
CURRENT DERATING



NOTE: For large capacitive load derate by up to 20%

## PI SERIES MECHANICAL OUTLINE

Dielectric test voltage 2500 volts rms, max. 50-60Hz

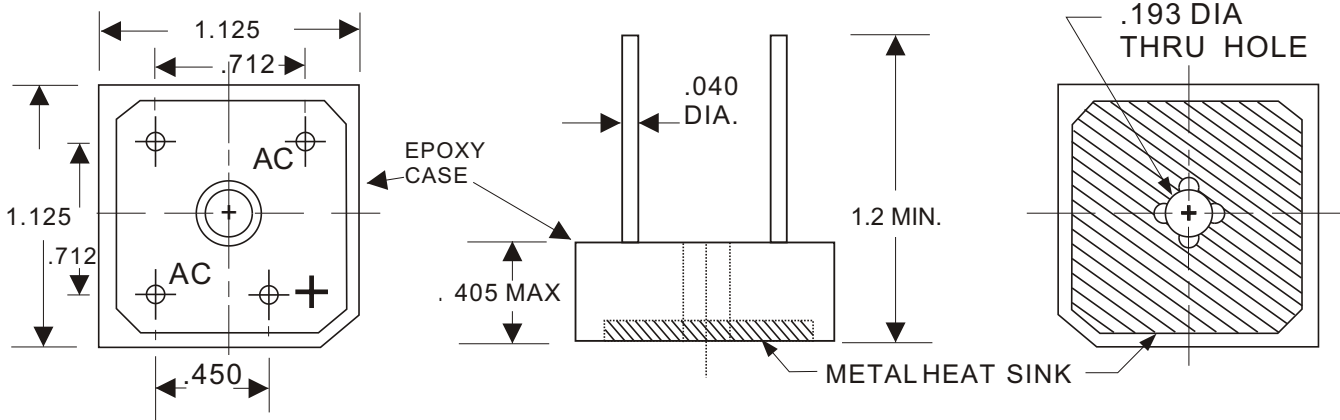

NOTE: A thin film of silicone thermal compound is recommended between the Minibridge® case and mounting surface for improved thermal conduction. Higher dielectric strengths available. Consult factory.

**ELECTRONIC DEVICES, INC.** DESIGNERS AND MANUFACTURERS OF SOLID STATE DEVICES SINCE 1951.  
21 GRAY OAKS AVENUE \* YONKERS, NEW YORK 10710 914-965-4400 \* FAX 914-965-5531 \* 1-800-678-0828  
e-mail: sales@edidiodes.com \* website: http://www.edidiodes.com