

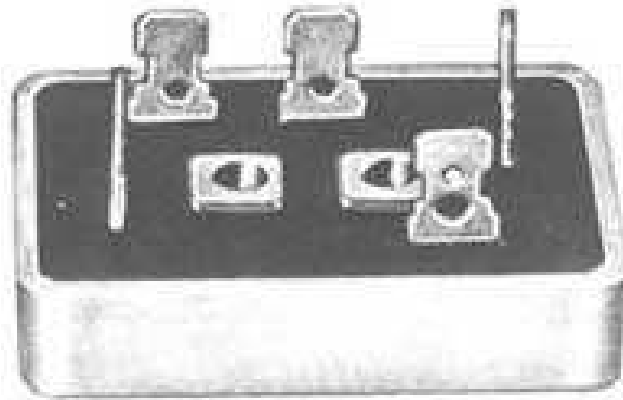

PBTR

FAST RECOVERY MINIBRIDGE[®]
200 NANOSECOND RECOVERY
17 AMPERE THREE-PHASE FULL-WAVE BRIDGES
HEAT SINK AND CHASSIS MOUNTING



RUL This mark indicates recognition under the component program of Underwriters Laboratories, Inc.

PBTR SERIES

PRV/leg	50V	100V	200V	400V	600V	800V	1000V
Type No.	PBTR05	PBTR10	PBTR20	PBTR40	PBTR60	PBTR80	PBTR100

ELECTRICAL CHARACTERISTICS PER LEG (at T_A=25 °C Unless Otherwise Specified)

Max. Forward Voltage Drop, V _F = 1.4 V @ I _F =	2.0	Amp
Max. DC Reverse Current @ PRV and 25°C, I _R	10	μA
Max. DC Reverse Current @ PRV and 100°C, I _R	300	μA
Max. Peak Surge Current, I _{FSM} (8.3ms)	200	Amp
Max. Reverse Recovery Time, T _{rr} (Fig.1)	200	nanosec.
Storage Temperature Range, T _{STG}	-55 to +175	°C
Thermal Resistance (Total Bridge), R _{θj-c}	3.5typ.	°C/W

EDI reserves the right to change these specifications at any time without notice.

Figure 1
CURRENT DERATING

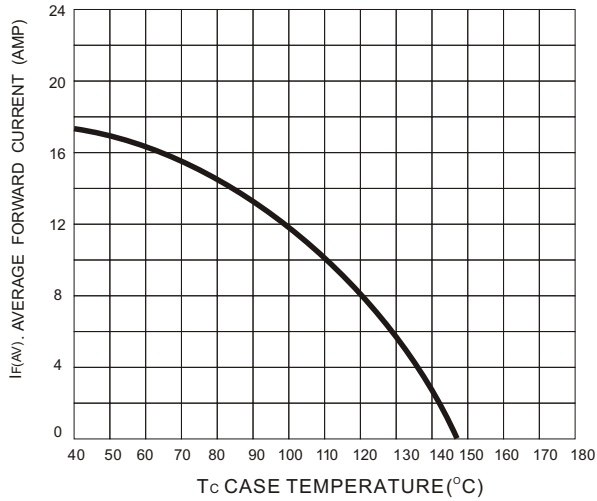

Figure 2
POWER DISSIPATION

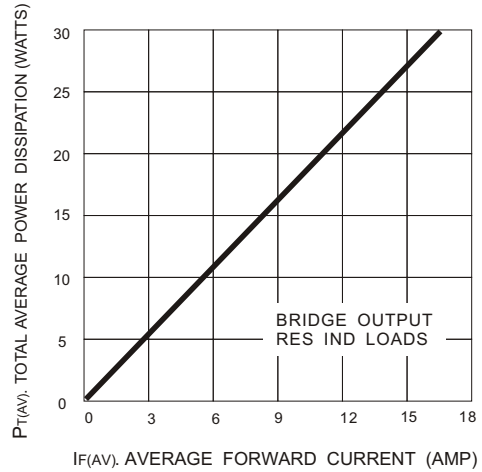

Figure 3
NON-REPETITIVE SURGE CURRENT

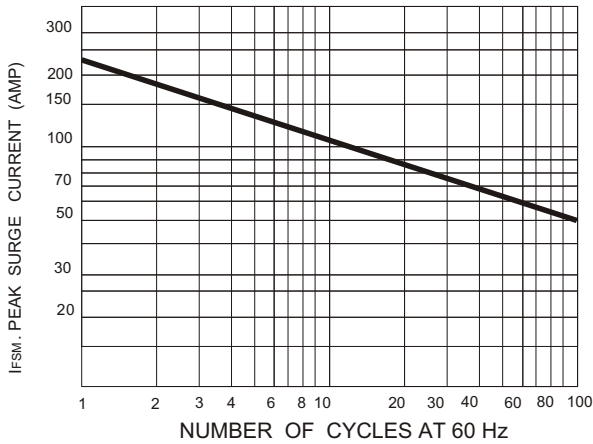
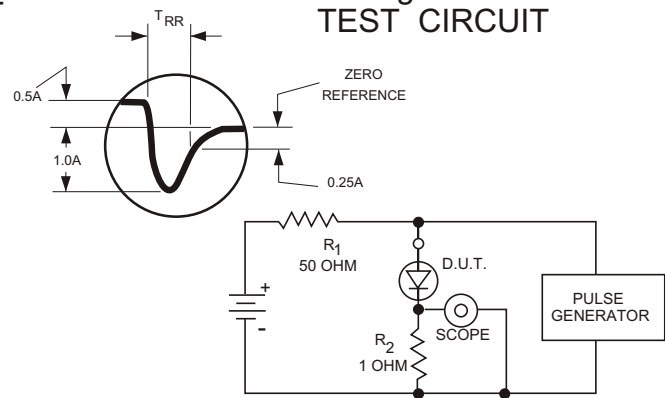

Figure 4
TEST CIRCUIT



R₁, R₂ NON-INDUCTIVE RESISTORS
PULSE GENERATOR - HEWLETT
PACKARD 214A OR EQUIV.
IKC REP. RATE, 10 μSEC. PULSE WIDTH
ADJUST PULSE AMPLITUDE FOR PEAK I_R

PBTR SERIES MECH. OUTLINE

Dielectric test voltage 1500 volts rms, max. 50-60 Hz

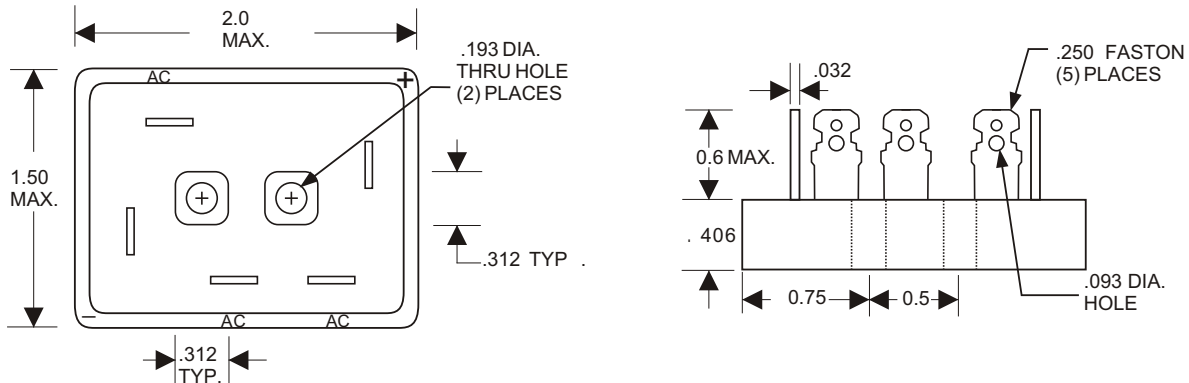

- NOTE: 1. Corrosion resistant terminals designed for .250 female quick connector, wrap around or solder.
2. A thin film of silicone thermal compound is recommended between the Minibrige® case and mounting surface for improved thermal conduction.

ELECTRONIC DEVICES, INC. DESIGNERS AND MANUFACTURERS OF SOLID STATE DEVICES SINCE 1951.

21 GRAY OAKS AVENUE * YONKERS, NEW YORK 10710 914-965-4400 * FAX 914-965-5531 * 1-800-678-0828

e-mail: sales@edidiodes.com * website: http://www.edidiodes.com