

# XThin® LEDs

## CxxxXT290-Sxx00-A

Cree's XThin LEDs are the next generation of solid-state LED emitters that combine highly efficient InGaN materials with Cree's proprietary G•SiC® substrate to deliver superior price/performance for high-intensity LEDs. These LED chips have a geometrically enhanced Epi-down design to maximize light extraction efficiency and require only a single wire bond connection. These vertically structured LED chips are approximately 115 microns in height and require a low forward voltage. Cree's XT™ chips are tested for conformity to optical and electrical specifications and the ability to withstand 1000V ESD. Applications for XThin LEDs include next-generation mobile appliances for use in their LCD backlights and digital camera flash where brightness, sub-miniaturization, and low power consumption are required.

### FEATURES

- XThin LED Performance
  - ♦ 460 & 470 nm
    - XT-12™ – 12.0 mW min.
    - XT-16™ – 16.0 mW min.
    - XT-18™ – 18.0 mW min.
    - XT-21™ – 21.0 mW min.
    - XT-24™ – 24.0 mW min.
  - ♦ 505nm – 8.5 mW min.
  - ♦ 527nm – 7.0 mW min.
- Thin 115 µm Chip
- Low Forward Voltage - 3.2 Typical at 20 mA
- Single Wire Bond Structure
- Class 2 ESD Rating

### APPLICATIONS

- Cellular Phone LCD Backlighting
- Digital Camera Flash for Mobile Appliance
- Mobile Phone Key Pads
  - White LEDs
  - Blue LEDs
  - Green LEDs
- Automotive Dashboard Lighting
- LED Video Displays
- Audio Product Display Lighting
- Traffic Signals

### CxxxXT290-Sxx00-A Chip Diagram

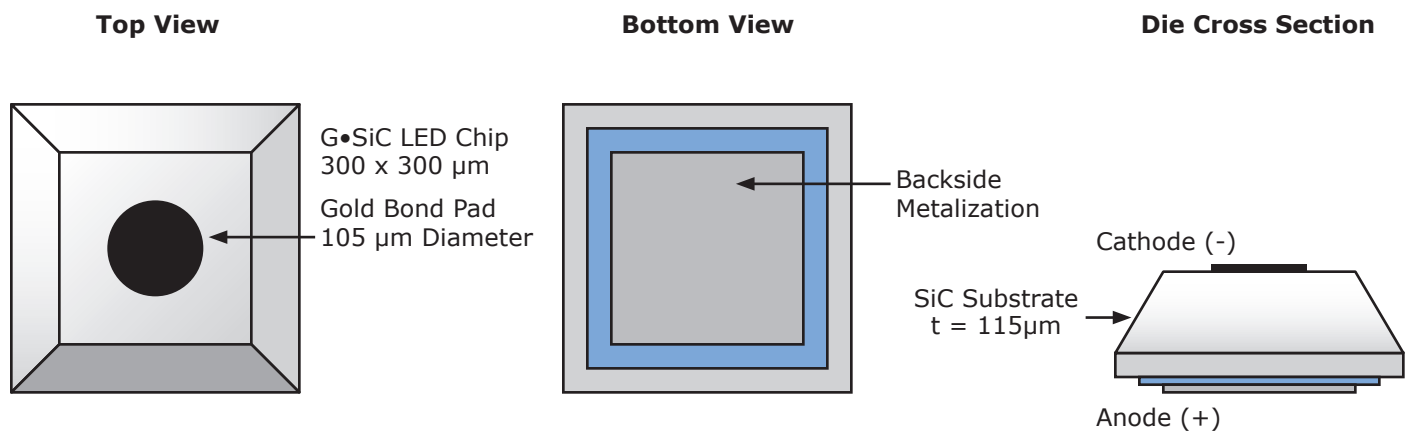

Maximum Ratings at $T_A = 25^\circ\text{C}$ <small>Notes 1&amp;3</small>		CxxxXT290-Sxx00-A
DC Forward Current		30mA
Peak Forward Current (1/10 duty cycle @ 1kHz)		100mA
LED Junction Temperature		125°C
Reverse Voltage		5 V
Operating Temperature Range		-40°C to +100°C
Storage Temperature Range		-40°C to +100°C
Electrostatic Discharge Threshold (HBM) <sup>Note 2</sup>		1000V
Electrostatic Discharge Classification (MIL-STD-883E) <sup>Note 2</sup>		Class 2

Typical Electrical/Optical Characteristics at $T = 25^\circ\text{C}$ , $I_f = 20\text{mA}$ <small>Note 3</small>					
Part Number	Forward Voltage ( $V_f$ , V)			Reverse Current [ $I(V_r=5V)$ , $\mu\text{A}$ ]	Full Width Half Max ( $\lambda_{dr}$ , nm)
	Min.	Typ.	Max.	Max.	Typ.
C460XT290-Sxx00-A	2.7	3.2	3.7	2	21
C470XT290-Sxx00-A	2.7	3.2	3.7	2	22
C505XT290-S0100-A	2.7	3.2	3.7	2	30
C527XT290-S0100-A	2.7	3.2	3.7	2	35

Mechanical Specifications		CxxxXT290-Sxx00-A	
Description	Dimension	Tolerance	
P-N Junction Area ( $\mu\text{m}$ )	250 x 250	$\pm 25$	
Top Area ( $\mu\text{m}$ )	200 x 200	$\pm 25$	
Bottom Area ( $\mu\text{m}$ )	300 x 300	$\pm 25$	
Chip Thickness ( $\mu\text{m}$ )	115	$\pm 15$	
Au Bond Pad Diameter ( $\mu\text{m}$ )	105	-5, +15	
Au Bond Pad Thickness ( $\mu\text{m}$ )	1.2	$\pm 0.5$	
Back Contact Metal Area ( $\mu\text{m}$ )	210 x 210	$\pm 25$	
Back Contact Metal Thickness ( $\mu\text{m}$ ) (Au/Sn) <sup>Note 4</sup>	1.7	$\pm 0.3$	

**Notes:**

- Maximum ratings are package dependent. The above ratings were determined using a T-1 3/4 package (with Hysol OS4000 epoxy) for characterization. Ratings for other packages may differ. The forward currents (DC and Peak) are not limited by the die but by the effect of the LED junction temperature on the package. The junction temperature limit of 125°C is a limit of the T-1 3/4 package; junction temperature should be characterized in a specific package to determine limitations. Assembly processing temperature must not exceed 325°C (< 5 seconds). See Cree Xthin Applications Note for more assembly process information.
- Product resistance to electrostatic discharge (ESD) according to the HBM is measured by simulating ESD using a rapid avalanche energy test (RAET). The RAET procedures are designed to approximate the maximum ESD ratings shown. The RAET procedure is performed on each die. The ESD classification of Class 2 is based on sample testing according to MIL-STD-883E.
- All products conform to the listed minimum and maximum specifications for electrical and optical characteristics when assembled and operated at 20 mA within the maximum ratings shown above. Efficiency decreases at higher currents. Typical values given are within the range of average values expected by manufacturer in large quantities and are provided for information only. All measurements were made using lamps in T-1 3/4 packages (with Hysol OS4000 epoxy). Optical characteristics measured in an integrating sphere using Illuminance E.
- Back contact metal is 80%/20% Au/Sn by weight, with target eutectic melting temperature of approximately 282°C. See XBright® Applications Note for detailed packaging recommendations.
- Caution: To avoid leakage currents and achieve maximum output efficiency, die attach material must not contact the side of the chip. See Cree XBright Applications Note for more information.
- XThin chips are shipped with the junction side down, not requiring a die transfer prior to die attach.
- Specifications are subject to change without notice.

## Standard Bins for CxxxXT290-Sxx00-A

LED chips are sorted to the radiant flux and dominant wavelength bins shown. A sorted die sheet contains die from only one bin. Sorted die kit (CxxxXT290-Sxx00-A) orders may be filled with any or all bins (CxxxXT290-01xx-A) contained in the kit. All radiant flux and dominant wavelength values shown and specified are at If = 20mA.

### XT-24

#### C460XT290-S2400-A

Radiant Flux	24.0 mW	C460XT290-0117-A	C460XT290-0118-A	C460XT290-0119-A	C460XT290-0120-A
		455 nm	457.5 nm	460 nm	462.5 nm
<b>Dominant Wavelength</b>					

### XT-21

#### C460XT290-S2100-A

Radiant Flux	24.0 mW	C460XT290-0117-A	C460XT290-0118-A	C460XT290-0119-A	C460XT290-0120-A	
	21.0 mW	C460XT290-0113-A	C460XT290-0114-A	C460XT290-0115-A	C460XT290-0116-A	
		455 nm	457.5 nm	460 nm	462.5 nm	465 nm
<b>Dominant Wavelength</b>						

### XT-18

#### C460XT290-S1800-A

Radiant Flux	24.0 mW	C460XT290-0117-A	C460XT290-0118-A	C460XT290-0119-A	C460XT290-0120-A	
	21.0 mW	C460XT290-0113-A	C460XT290-0114-A	C460XT290-0115-A	C460XT290-0116-A	
	18.0 mW	C460XT290-0109-A	C460XT290-0110-A	C460XT290-0111-A	C460XT290-0112-A	
		455 nm	457.5 nm	460 nm	462.5 nm	465 nm
<b>Dominant Wavelength</b>						

### XT-16

#### C460XT290-S1600-A

Radiant Flux	24.0 mW	C460XT290-0117-A	C460XT290-0118-A	C460XT290-0119-A	C460XT290-0120-A	
	21.0 mW	C460XT290-0113-A	C460XT290-0114-A	C460XT290-0115-A	C460XT290-0116-A	
	18.0 mW	C460XT290-0109-A	C460XT290-0110-A	C460XT290-0111-A	C460XT290-0112-A	
	16.0 mW	C460XT290-0105-A	C460XT290-0106-A	C460XT290-0107-A	C460XT290-0108-A	
		455 nm	457.5 nm	460 nm	462.5 nm	465 nm
<b>Dominant Wavelength</b>						

**Standard Bins for CxxxXT290-Sxx00-A (continued)**

**XT-12**

**C460XT290-S1200-A**

<b>Radiant Flux</b>	24.0 mW	C460XT290-0117-A	C460XT290-0118-A	C460XT290-0119-A	C460XT290-0120-A	
	21.0 mW	C460XT290-0113-A	C460XT290-0114-A	C460XT290-0115-A	C460XT290-0116-A	
	18.0 mW	C460XT290-0109-A	C460XT290-0110-A	C460XT290-0111-A	C460XT290-0112-A	
	16.0 mW	C460XT290-0105-A	C460XT290-0106-A	C460XT290-0107-A	C460XT290-0108-A	
	12.0 mW	C460XT290-0101-A	C460XT290-0102-A	C460XT290-0103-A	C460XT290-0104-A	
		455 nm	457.5 nm	460 nm	462.5 nm	465 nm
		<b>Dominant Wavelength</b>				

**XT-21**

**C470XT290-S2100-A**

<b>Radiant Flux</b>	21.0 mW	C470XT290-0113-A	C470XT290-0114-A	C470XT290-0115-A	C470XT290-0116-A	
		465 nm	467.5 nm	470 nm	472.5 nm	475 nm
		<b>Dominant Wavelength</b>				

**XT-18**

**C470XT290-S1800-A**

<b>Radiant Flux</b>	21.0 mW	C470XT290-0113-A	C470XT290-0114-A	C470XT290-0115-A	C470XT290-0116-A	
	18.0 mW	C470XT290-0109-A	C470XT290-0110-A	C470XT290-0111-A	C470XT290-0112-A	
		465 nm	467.5 nm	470 nm	472.5 nm	475 nm
		<b>Dominant Wavelength</b>				

**XT-16**

**C470XT290-S1600-A**

<b>Radiant Flux</b>	21.0 mW	C470XT290-0113-A	C470XT290-0114-A	C470XT290-0115-A	C470XT290-0116-A	
	18.0 mW	C470XT290-0109-A	C470XT290-0110-A	C470XT290-0111-A	C470XT290-0112-A	
	16.0 mW	C470XT290-0105-A	C470XT290-0106-A	C470XT290-0107-A	C470XT290-0108-A	
		465 nm	467.5 nm	470 nm	472.5 nm	475 nm
		<b>Dominant Wavelength</b>				

**Standard Bins for CxxxXT290-Sxx00-A (continued)**

**XT-12**

**C470XT290-S1200-A**

<b>Radiant Flux</b>	21.0 mW	C470XT290-0113-A	C470XT290-0114-A	C470XT290-0115-A	C470XT290-0116-A	
	18.0 mW	C470XT290-0109-A	C470XT290-0110-A	C470XT290-0111-A	C470XT290-0112-A	
	16.0 mW	C470XT290-0105-A	C470XT290-0106-A	C470XT290-0107-A	C470XT290-0108-A	
	12.0 mW	C470XT290-0101-A	C470XT290-0102-A	C470XT290-0103-A	C470XT290-0104-A	
		465 nm	467.5 nm	470 nm	472.5 nm	475 nm
		<b>Dominant Wavelength</b>				

**C505XT290-S0100-A**

<b>Radiant Flux</b>	10.5 mW	C505XT290-0103-A	C505XT290-0104-A	
	8.5 mW	C505XT290-0101-A	C505XT290-0102-A	
		500 nm	505 nm	510 nm
		<b>Dominant Wavelength</b>		

**C527XT290-S0100-A**

<b>Radiant Flux</b>	10.0 mW	C527XT290-0110-A	C527XT290-0111-A	C527XT290-0112-A	
	9.0 mW	C527XT290-0107-A	C527XT290-0108-A	C527XT290-0109-A	
	8.0 mW	C527XT290-0104-A	C527XT290-0105-A	C527XT290-0106-A	
	7.0 mW	C527XT290-0101-A	C527XT290-0102-A	C527XT290-0103-A	
		520 nm	525 nm	530 nm	535 nm
		<b>Dominant Wavelength</b>			

## Characteristic Curves

These are representative measurements for the XThin product. Actual curves will vary slightly for the various radiant flux and dominant wavelength bins.

