

SuperBlue™ Generation II LEDs

Preliminary Data Sheet

C430CB290-S2100

Cree's SuperBlue LEDs combine highly efficient GaN with Cree's proprietary G•SiC® substrate to deliver the ultimate price/performance for high-intensity blue LEDs. The C430CB290-S2100 is designed for automotive applications or any application where wavelength stability and chip robustness are critical.

FEATURES

- Low Wavelength Variation
 - 461-465 nm at 20 mA
- High Performance - 1.3 mW
- Superior SiC Substrate Technology
- Excellent Chip-to-Chip Consistency
- High Reliability
- Single Wire Bond Structure
- Class 2 ESD Rating

APPLICATIONS

- Automotive Applications
 - Dashboard Lighting
 - Interior Lighting
 - Toggle Switch Lighting
- Electronic Signs and Displays
- Indicator Lights

C430CB290-S2100 Chip Diagram

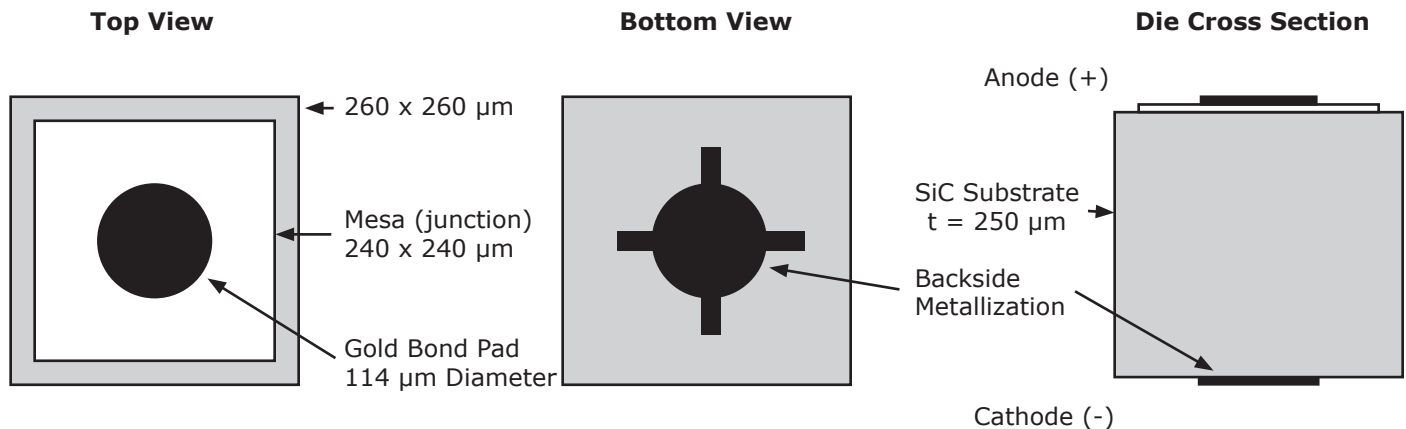

Maximum Ratings at $T_A = 25^\circ\text{C}$ <small>Notes 1&3</small>		C430CB290-S2100
DC Forward Current		30 mA
Peak Forward Current (1/10 duty cycle @ 1kHz)		70 mA
LED Junction Temperature		125°C
Reverse Voltage		5 V
Operating Temperature Range		-40°C to +100°C
Storage Temperature Range		-40°C to +100°C
Electrostatic Discharge Threshold (HBM) <small>Note 2</small>		1000 V
Electrostatic Discharge Classification (MIL-STD-883E) <small>Note 2</small>		Class 2

Typical Electrical/Optical Characteristics at $T_A = 25^\circ\text{C}$, $I_f = 20\text{ mA}$ <small>Note 3</small>										
Part Number	Forward Voltage (V_f , V)		Radiant Flux (P, mW)		Reverse Current [$I(V_r=5V)$, μA]	Peak Wavelength (λ_p , nm)	Dominant Wavelength (λ_d , nm)			Full Width Half Max (λ_D , nm)
	Typ.	Max.	Min.	Typ.	Max.	Typ.	Min.	Typ.	Max.	Typ.
C430CB290-S2100	4.0	4.5	0.85	1.3	10	423	461	463	465	59

Mechanical Specifications		C430CB290-S2100
Description	Dimension	Tolerance
P-N Junction Area (μm^2)	240 x 240	± 35
Top Area (μm^2)	260 x 260	± 35
Bottom Area (μm^2)	260 x 260	± 35
Chip Thickness (μm)	250	± 25
Au Bond Pad Diameter (μm)	114	± 20
Au Bond Pad Thickness (μm)	1.1	± 0.5
Back Contact Metal Diameter (μm)	114	± 20

Notes:

- Maximum ratings are package dependent. The above ratings were determined using a T-1 3/4 package (with Hysol OS4000 epoxy) for characterization. Ratings for other packages may differ. The forward currents (DC and Peak) are not limited by the die but by the effect of the LED junction temperature on the package. The junction temperature limit of 125°C is a limit of the T-1 3/4 package; junction temperature should be characterized in a specific package to determine limitations. Assembly processing temperature must not exceed 325°C (<5 seconds).
- Product resistance to electrostatic discharge (ESD) according to the HBM is measured by simulating ESD using a rapid avalanche energy test (RAET). The RAET procedures are designed to approximate the maximum ESD ratings shown. The ESD classification of Class 2 is based on sample testing according to MIL-STD-883E.
- All products conform to the listed minimum and maximum specifications for electrical and optical characteristics when assembled and operated at 20 mA within the maximum ratings shown above. Efficiency decreases at higher currents. Typical values given are within the range of average values expected by the manufacturer in large quantities and are provided for information only. All measurements were made using lamps in T-1 3/4 packages (with Hysol OS4000 epoxy). Optical characteristics measured in an integrating sphere using Illuminance A.

Characteristic Curves

These are representative measurements for the CB290 LED product. Actual curves will vary slightly for the various radiant flux and dominant wavelength bins.

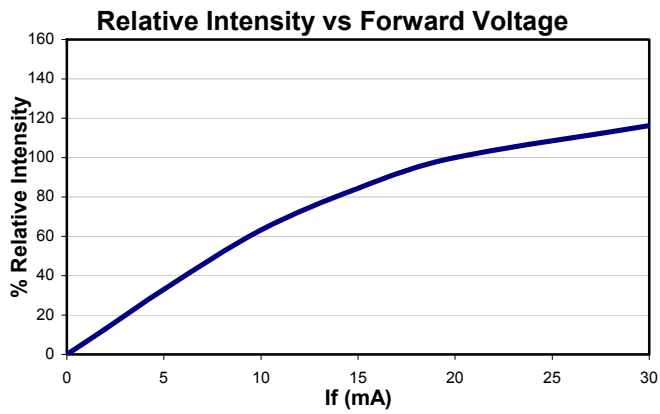
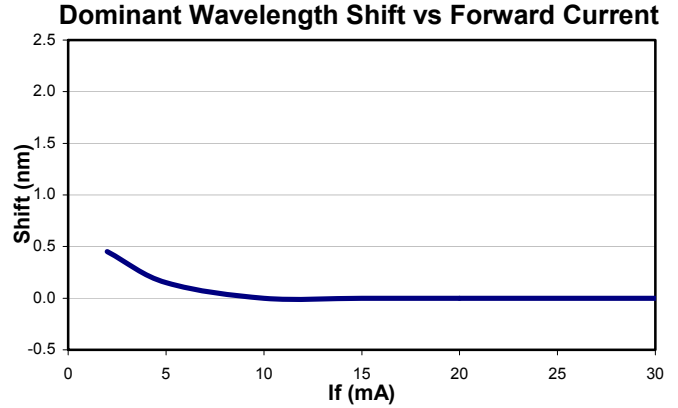
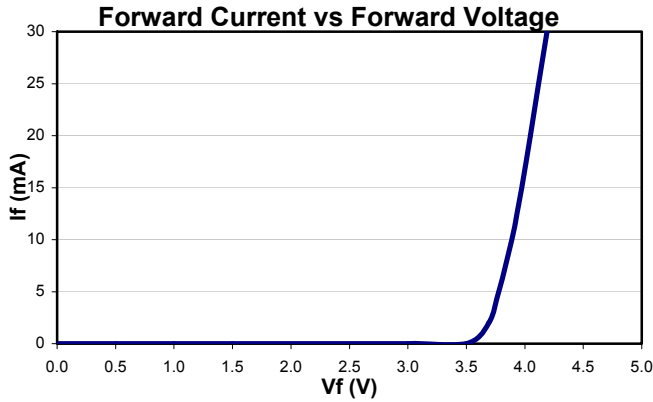

Radiation Pattern

This is a representative radiation pattern for the CB290 LED product. Actual patterns will vary slightly for each chip.

