

TOSHIBA CDMOS Integrated Circuit Silicone Monolithic

TC62D723FNG

16-Output constant current LED driver with the output gain control function and the PWM grayscale function

1.Feature

The TC62D723FNG is LED drivers which have the sink-type constant current output.

The output gain control function of 8-bit and the PWM grayscale function of 16, 14, 12, and 10-bit are built into this IC.

Output current value of 16 channels is set by one external resistance.

In addition, the thermal shutdown function, the output open detection function, and the output short detection function are built in.

This IC is most suitable for lighting the LED module and the display.

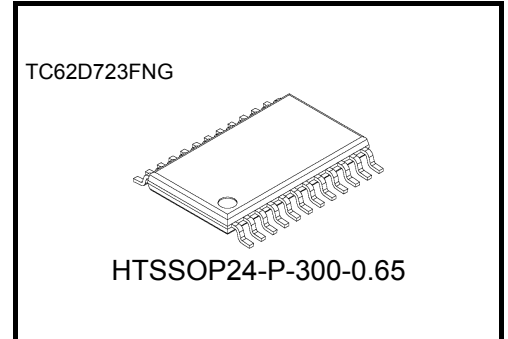

Weight
HTSSOP24-P-300-0.65 : 0.10 g (Typ.)

2.Characteristics

- Supply voltage : $V_{DD} = 3.0$ to 5.5 V
- 16-output built-in
- Output current setup range : $I_{OUT} = 1.5$ to 90 mA
- Constant current output accuracy
(@ $R_{EXT} = 1.2$ k Ω , $V_{OUT} = 1.0$ V, $V_{DD} = 3.3$ V, 5.0 V)
 - : S rank; Between outputs ± 1.5 % (max)
 - : S rank; Between devices: ± 1.5 % (max)
 - : N rank; Between outputs ± 2.5 % (max)
 - : N rank; Between devices: ± 2.5 % (max)
- Output voltage : $V_{OUT} = 17$ V (MAX)
- I/O interface : CMOS interfaces (Input of a schmitt trigger)
- Data transfer frequency : $f_{SCK} = 30$ MHz (MAX)
- PWM frequency : $f_{PWM} = 33$ MHz (MAX)
- Operation temperature range : $T_{opr} = -40$ to 85 °C
- 8-bit (256 steps) output gain control function built-in.
- PWM grayscale function built-in. (PWM resolution is selectable)
 - 16-bit (65536 steps), 14-bit (16384 steps)
 - 12-bit (4096 steps), 10-bit (1024 steps)
 - Selection of the one-shot output PWM mode or the repeat PWM output mode is possible.
- Thermal shutdown function (TSD) built-in.
- Output error detection function built-in.
 - This function has the automatic operation and the command input manual operation.
 - Output open detection function (OOD) and output short detection function (OSD) built-in.
- Power-on-reset function built-in. (When the power supply is turned on, internal data is reset)
- Stand-by function built-in. ($I_{DD} = 1\mu$ A at standby mode)
- Output delay function built-in. (Output switching noise is reduced)
- Package : HTSSOP24-P-300-0.65

For detailed part naming conventions, contact your local Toshiba sales representative or distributor.

3. Block Diagram

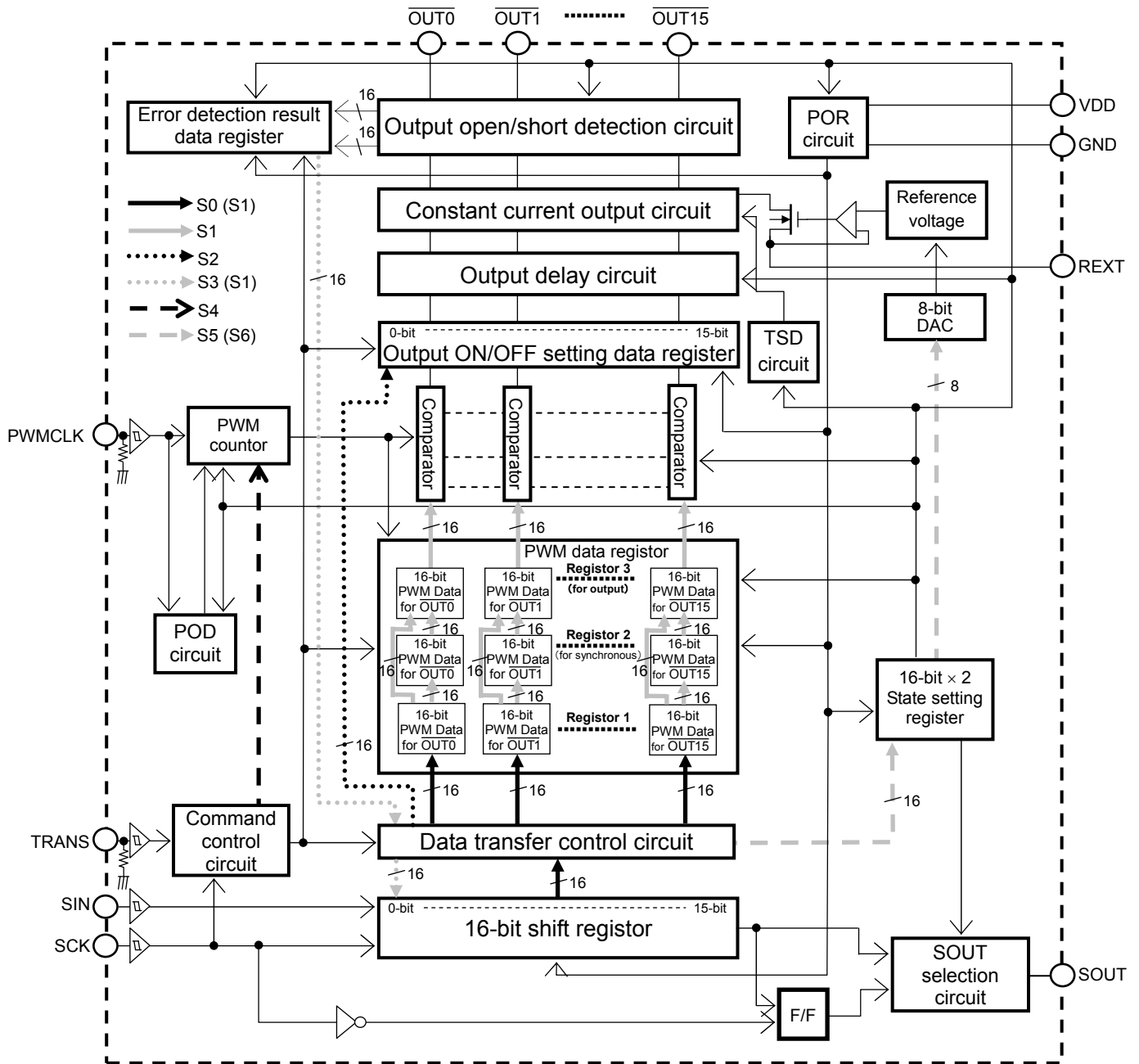

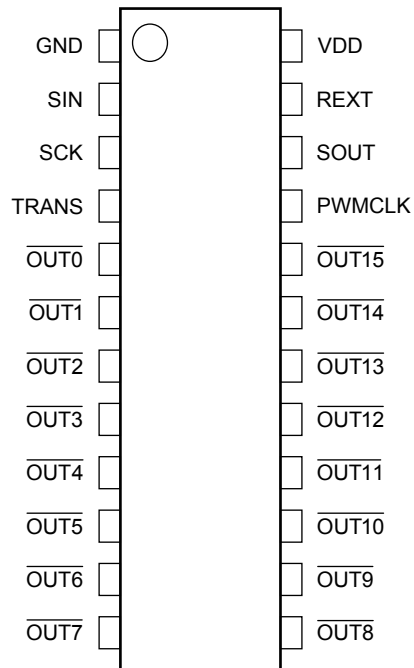
4.Pin Assignment (top view)

5.Pin Description

Pin No.	Pin Name	I/O	Function
1	GND	—	The ground pin.
2	SIN	I	The serial data input pin.
3	SCK	I	The serial data transfer clock input pin.
4	TRANS	I	The data transfer command input pin.
5	$\overline{\text{OUT0}}$	O	The sink type constant current output pin.
6	$\overline{\text{OUT1}}$	O	The sink type constant current output pin.
7	$\overline{\text{OUT2}}$	O	The sink type constant current output pin.
8	$\overline{\text{OUT3}}$	O	The sink type constant current output pin.
9	$\overline{\text{OUT4}}$	O	The sink type constant current output pin.
10	$\overline{\text{OUT5}}$	O	The sink type constant current output pin.
11	$\overline{\text{OUT6}}$	O	The sink type constant current output pin.
12	$\overline{\text{OUT7}}$	O	The sink type constant current output pin.
13	$\overline{\text{OUT8}}$	O	The sink type constant current output pin.
14	$\overline{\text{OUT9}}$	O	The sink type constant current output pin.
15	$\overline{\text{OUT10}}$	O	The sink type constant current output pin.
16	$\overline{\text{OUT11}}$	O	The sink type constant current output pin.
17	$\overline{\text{OUT12}}$	O	The sink type constant current output pin.
18	$\overline{\text{OUT13}}$	O	The sink type constant current output pin.
19	$\overline{\text{OUT14}}$	O	The sink type constant current output pin.
20	$\overline{\text{OUT15}}$	O	The sink type constant current output pin.
21	PWMCLK	I	The reference clock input pin for PWM grayscale control. One cycle of the input clock becomes a minimum pulse width of the PWM output.
22	SOUT	O	The serial data output pin.
23	REXT	—	The constant current value setting resistor connection pin.
24	VDD	I	The power supply input pin.

6. Equivalent circuit of input and output

1. SCK, SIN

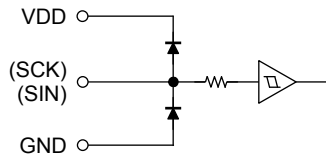

2. PWMCLK, TRANS

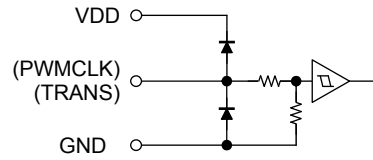

3. SOUT

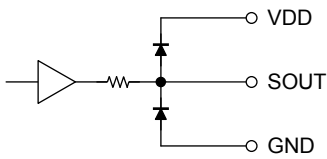

4. $\overline{\text{OUT0}}$ to $\overline{\text{OUT15}}$

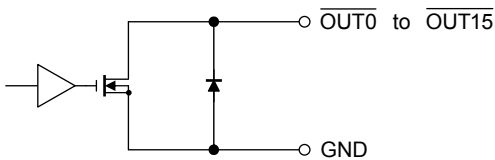

7. Explanation of the function (Basic data input pattern)

Data input is done with the SIN pin and the SCK pin.

Command selection is done with the SCK pin and the TRANS pin.

About the operation of each command

Command	Number of SCK pulses at TRANS="H" Note3	Operation
S0	0,1	The PWM data in the 16-bit shift register is transmitted to the PWM data register 1.
S1	2,3	1. The PWM data in the PWM data register 1 is transmitted to the PWM data register 2 or 3. Note1 2. The automatic output open/short detection result data is transmitted to the 16-bit shift register. Note2 3. PWM output start.
S2	7,8	Input of the output ON/OFF data. (When this function is not used, this input is unnecessary.)
S3	9,10	The manual output open/short detection functions are executed. Note2 The manual output open/short detection result data is transmitted to the 16-bit shift register. Note2
S4	11,12	Reset of the internal PWM counter.
S5	13,14	Input of the state setting data (1).
S6	15,16	Input of the state setting data (2).

Note1: Transmitted register changes by a PWM counter synchronization setting.

Note2: This operation is performed when the output open/short detection function is "Active" setting.

Note3: Other SCK numbers are disregarded.

•S0 command (The PWM data is transmitted to the PWM data register 1.)

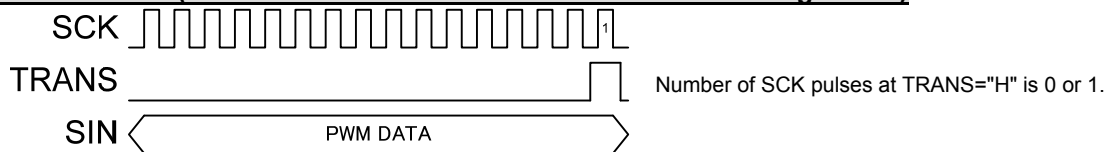

•S1 command (The PWM data is transmitted to the PWM data register 2 or 3.)



•S2 command (Input of the output ON/OFF data.)

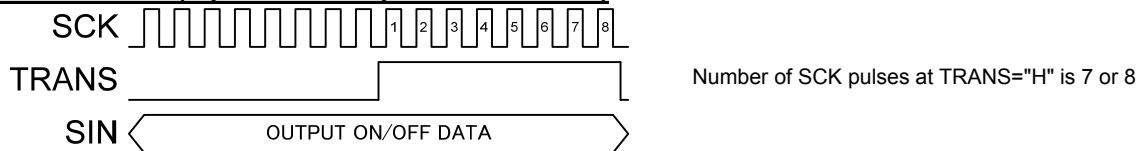

•S3 command (The output open/short detection functions manual operation is executed.)



•S4 command (Reset of the internal PWM counter.)



•S5 command (Input of the state setting data (1).)

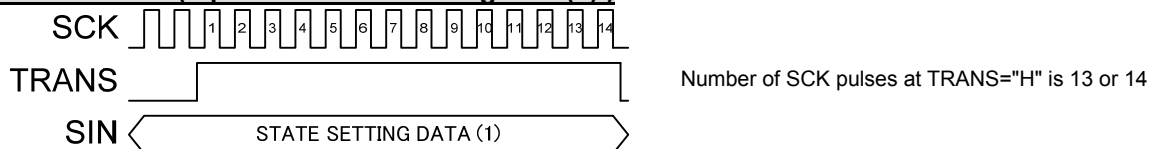

•S6 command (Input of the state setting data (2).)

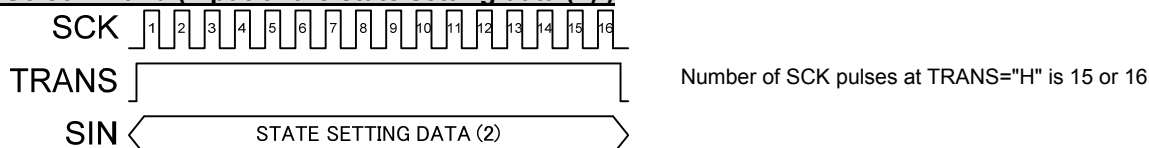

8. About the operation of each command

8-1-1) S0 command (The PWM data is transmitted to the PWM data register 1.)

Operation) In the number of SCK pulses at TRANS="H" is 0 or 1, the following operation is executed.
The PWM data in the 16-bit shift register is transmitted to the PWM data register 1.

It is necessary to repeat this command 16 times to input the PWM data of $\overline{\text{OUT0}}$ to $\overline{\text{OUT15}}$.

The order of the PWM data transfer is the following.

$\overline{\text{OUT15}} \rightarrow \overline{\text{OUT14}} \rightarrow \overline{\text{OUT13}} \rightarrow \overline{\text{OUT12}} \rightarrow \overline{\text{OUT11}} \rightarrow \overline{\text{OUT10}} \rightarrow \overline{\text{OUT9}} \rightarrow \overline{\text{OUT8}}$
 $\rightarrow \overline{\text{OUT7}} \rightarrow \overline{\text{OUT6}} \rightarrow \overline{\text{OUT5}} \rightarrow \overline{\text{OUT4}} \rightarrow \overline{\text{OUT3}} \rightarrow \overline{\text{OUT2}} \rightarrow \overline{\text{OUT1}} \rightarrow \overline{\text{OUT0}}$

Basic input pattern of S0 command)

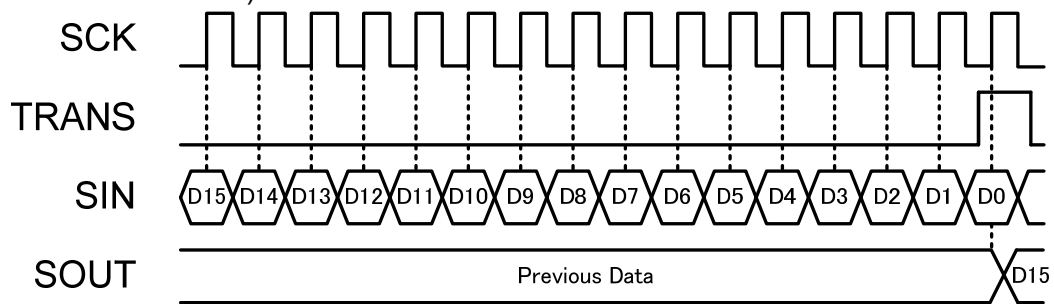

SOUT is operation at the time of S6 command N0=0 conditions.

8-1-2) Input form of the PWM data

PWM resolution is set by the S5 command. Default setting is "16-bit".

1. 16-bit PWM setting

MSB															LSB	PWM setting (reference)	
D15	D14	D13	D12	D11	D10	D9	D8	D7	D6	D5	D4	D3	D2	D1	D0		
0	0	0	0	0	0	0	0	0	0	0	0	0	0	0	0	0	0/65535(Default)
0	0	0	0	0	0	0	0	0	0	0	0	0	0	0	0	1	1/65535
0	0	0	0	0	0	0	0	0	0	0	0	0	0	0	1	0	2/65535
⋮	⋮	⋮	⋮	⋮	⋮	⋮	⋮	⋮	⋮	⋮	⋮	⋮	⋮	⋮	⋮	⋮	⋮
1	1	1	1	1	1	1	1	1	1	1	1	1	1	1	0	1	65533/65535
1	1	1	1	1	1	1	1	1	1	1	1	1	1	1	1	0	65534/65535
1	1	1	1	1	1	1	1	1	1	1	1	1	1	1	1	1	65535/65535

D15 to D0 is serial-data-inputted at MSB first.

2. 14-bit PWM setting

MSB															LSB	PWM setting (reference)	
D15	D14	D13	D12	D11	D10	D9	D8	D7	D6	D5	D4	D3	D2	D1	D0		
Don't care	0	0	0	0	0	0	0	0	0	0	0	0	0	0	0	0	0/16383(Default)
	0	0	0	0	0	0	0	0	0	0	0	0	0	0	1	1	1/16383
	0	0	0	0	0	0	0	0	0	0	0	0	0	0	1	0	2/16383
	⋮	⋮	⋮	⋮	⋮	⋮	⋮	⋮	⋮	⋮	⋮	⋮	⋮	⋮	⋮	⋮	⋮
	1	1	1	1	1	1	1	1	1	1	1	1	1	1	0	1	16381/16383
	1	1	1	1	1	1	1	1	1	1	1	1	1	1	1	0	16382/16383
	1	1	1	1	1	1	1	1	1	1	1	1	1	1	1	1	16383/16383

D15 to D0 is serial-data-inputted at MSB first.

3. 12-bit PWM setting

MSB															LSB	PWM setting (reference)	
D15	D14	D13	D12	D11	D10	D9	D8	D7	D6	D5	D4	D3	D2	D1	D0		
Don't care	0	0	0	0	0	0	0	0	0	0	0	0	0	0	0	0	0/4095(Default)
	0	0	0	0	0	0	0	0	0	0	0	0	0	0	1	1	1/4095
	0	0	0	0	0	0	0	0	0	0	0	0	0	0	1	0	2/4095
	⋮	⋮	⋮	⋮	⋮	⋮	⋮	⋮	⋮	⋮	⋮	⋮	⋮	⋮	⋮	⋮	⋮
	1	1	1	1	1	1	1	1	1	1	1	1	1	1	0	1	4093/4095
	1	1	1	1	1	1	1	1	1	1	1	1	1	1	1	0	4094/4095
	1	1	1	1	1	1	1	1	1	1	1	1	1	1	1	1	4095/4095

D15 to D0 is serial-data-inputted at MSB first.

4. 10-bit PWM setting

MSB															LSB	PWM setting (reference)	
D15	D14	D13	D12	D11	D10	D9	D8	D7	D6	D5	D4	D3	D2	D1	D0		
Don't care	0	0	0	0	0	0	0	0	0	0	0	0	0	0	0	0	0/1023(Default)
	0	0	0	0	0	0	0	0	0	0	0	0	0	0	1	1	1/1023
	0	0	0	0	0	0	0	0	0	0	0	0	0	0	1	0	2/1023
	⋮	⋮	⋮	⋮	⋮	⋮	⋮	⋮	⋮	⋮	⋮	⋮	⋮	⋮	⋮	⋮	⋮
	1	1	1	1	1	1	1	1	1	1	1	1	1	1	0	1	1021/1023
	1	1	1	1	1	1	1	1	1	1	1	1	1	1	1	0	1022/1023
	1	1	1	1	1	1	1	1	1	1	1	1	1	1	1	1	1023/1023

D15 to D0 is serial-data-inputted at MSB first.

8-2-1) S1 command (The PWM data is transmitted to the PWM data register 2 or 3.)

Operation) In the number of SCK pulses at TRANS="H" is 2 or3, the following operation is executed.

1. The PWM data in the PWM data register 1 is transmitted to the PWM data register 2 or 3.
2. The automatic output open/short detection result data is transmitted to the 16-bit shift register. Note1
When internal PWM count is 1 to 21, the output open/short detection automatic operation is done.
3. The PWM output start.
 - In the case of the one-shot PWM output mode Note2
In the input of this command, the PWM output is turned on once.
When restarting by same PWM data, please input this command again.
 - In the case of the repeat PWM output mode Note2
In the input of this command, PWM output is output repeatedly.
In order to stop a PWM output, the input of a reset command is required.

Setting of PWM output mode is set by the S6 command.

Note) About the output operation when this command is input while PWM output.

1. When the PWM counter is the synchronous mode. Note3
After the present PWM output has ended, PWM output is started by new PWM data.
2. When the PWM counter is the asynchronous mode. Note3
The present PWM output is canceled and a PWM output is immediately started by new PWM data.

Setting of PWM output synchronization is set by the S6 command.

Basic input pattern of S1 command)

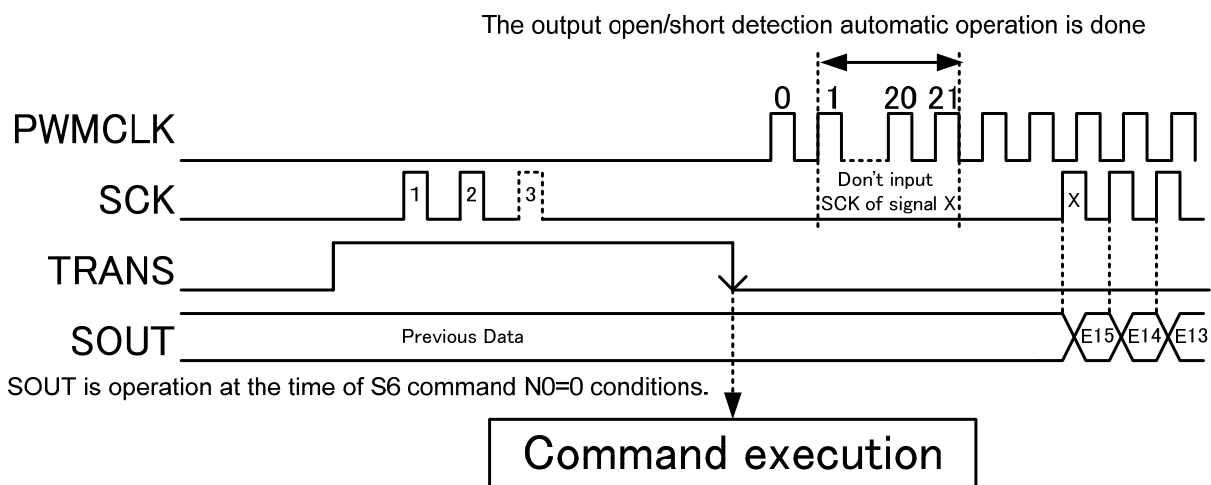

The first SCK (signal X) after this command is used for transmission of the output open/short detection result data. The input from SIN is not received. Note1
When internal PWM count is 1 to 21, the output open/short detection automatic operation is done.
Please do not input the first SCK (signal X) after S1 command during detection. Note1

Note1: This operation is performed when the output open/short detection function is "Active" setting.
The output open/short detection functions are set by S6 command.
Default setting is "Not Active".

Note2: PWM output system is set by the S6 command.
Default setting is "Repeat PWM output mode".

Note3: PWM output synchronization PWM resolution is set by the S6 command.
Default setting is "Synchronous mode".

8-2-2) Output form of the output open/short detection result data

It is transmitted to 16 bit-shift register in the following form.

MSB														LSB	
E15	E14	E13	E12	E11	E10	E9	E8	E7	E6	E5	E4	E3	E2	E1	E0
$\overline{\text{OUT15}}$	$\overline{\text{OUT14}}$	$\overline{\text{OUT13}}$	$\overline{\text{OUT12}}$	$\overline{\text{OUT11}}$	$\overline{\text{OUT10}}$	$\overline{\text{OUT9}}$	$\overline{\text{OUT8}}$	$\overline{\text{OUT7}}$	$\overline{\text{OUT6}}$	$\overline{\text{OUT5}}$	$\overline{\text{OUT4}}$	$\overline{\text{OUT3}}$	$\overline{\text{OUT2}}$	$\overline{\text{OUT1}}$	$\overline{\text{OUT0}}$

Error code (when output open detection function is effective)

The state of output	Error code	Condition of output
$V_{\text{OOD}} \geq V_{\text{DS}}$	0	Open
$V_{\text{OOD}} < V_{\text{DS}}$	1	Normal

Error code (when output short detection function is effective)

The state of output	Error code	Condition of output
$V_{\text{OSD}} \leq V_{\text{DS}}$	0	short-circuit
$V_{\text{OSD}} > V_{\text{DS}}$	1	Normal

Error code (when output open/short detection function is effective)

The state of output	Error code	Condition of output
$V_{\text{OOD}} \geq V_{\text{DS}}$ or $V_{\text{OSD}} \leq V_{\text{DS}}$	0	Open or short-circuit
$V_{\text{OOD}} < V_{\text{DS}}$ or $V_{\text{OSD}} > V_{\text{DS}}$	1	Normal
When both output error detection function is effective, Open and short-circuit are indistinguishable.		

When internal PWM count is 1 to 21, the output open/short detection automatic operation is done.

When the output is off during the output open/short detection execution, the error code becomes "1".

Setting of PWM output mode	Setting of PWM bits number	The PWM step that becomes error code "1" without relations in the state of the output pin.
Normal PWM output mode	16 bit PWM setting	0 to 20 PWM step setting
	14 bit PWM setting	
	12 bit PWM setting	
	10 bit PWM setting	
Division PWM output mode	16 bit PWM setting	0 to 2560 PWM step setting
	14 bit PWM setting	
	12 bit PWM setting	0 to 960 PWM step setting
	10 bit PWM setting	

The above table is unrelated at the time of the output open/short detection manual operation by S3 command.

8-3-1) S2 command (Input of the output ON/OFF data.)

When this function is not used, this input is unnecessary.

Operation) In the number of SCK pulses at TRANS="H" is 7 or 8, the following operation is executed.

Input of the output ON/OFF data.

Even if PWM data is not changed to 0 settings, ON/OFF of the output can be controlled.

Note) About the output operation when this command is input while PWM output.

1. When the PWM counter is the synchronous mode. Note1
The setting of this command is reflected in the next PWM output.
2. When the PWM counter is the asynchronous mode. Note1
The setting of this command is reflected immediately.

The PWM counter synchronization function is set by S6 command.

Basic input pattern of S2 command)

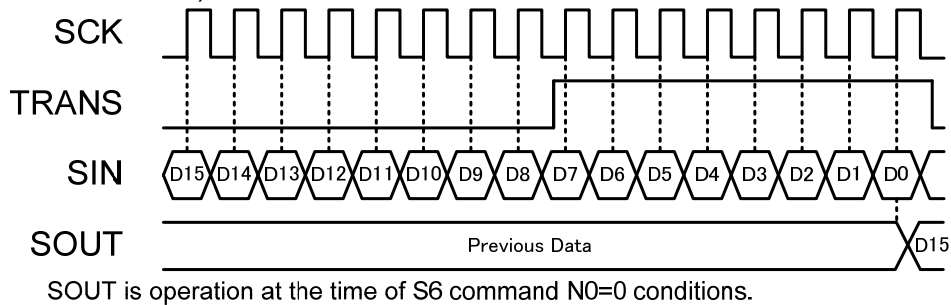

Note1: PWM output synchronization PWM resolution is set by the S6 command.

Default setting is "Synchronous mode".

8-3-2) Input form of the output ON/OFF data

MSB														LSB	
D15	D14	D13	D12	D11	D10	D9	D8	D7	D6	D5	D4	D3	D2	D1	D0
$\overline{\text{OUT15}}$	$\overline{\text{OUT14}}$	$\overline{\text{OUT13}}$	$\overline{\text{OUT12}}$	$\overline{\text{OUT11}}$	$\overline{\text{OUT10}}$	$\overline{\text{OUT9}}$	$\overline{\text{OUT8}}$	$\overline{\text{OUT7}}$	$\overline{\text{OUT6}}$	$\overline{\text{OUT5}}$	$\overline{\text{OUT4}}$	$\overline{\text{OUT3}}$	$\overline{\text{OUT2}}$	$\overline{\text{OUT1}}$	$\overline{\text{OUT0}}$

D15 to D0 is serial-data-inputted at MSB first.

The output ON/OFF data setting

Input Data	Setting
1	Output operates according to PWM data setting. (Default)
0	Output turn off

8-4) S3 command (The manual output open/short detection functions are executed.)

Operation) In the number of SCK pulses at TRANS="H" is 9 or 10, the following operation is executed. Note1
 The manual output open/short detection functions are executed.
 The output is compulsorily turned on during $t_{ON(S3)}$ with about 80 μ A. And detection is done.
 The manual output open/short detection result data is transmitted to the 16-bit shift register.
 $t_{ON(S3)}$ is about 800ns.

Note) Please set TRANS and SCK to "L" during error detection execution time ($t_{ON(S3)}$) .

PWM one shot mode

When PWM output is off , it will be error detection execution period once this command is executed.

If this command is input when PWM output is on, it will be error detection execution period after PWM output finishes.

PWM repeat mode

When repeat mode is selected, please execute this command after inputting S4 command.

It will be error detection execution period once this command is executed.

Basic input pattern of S3 command)

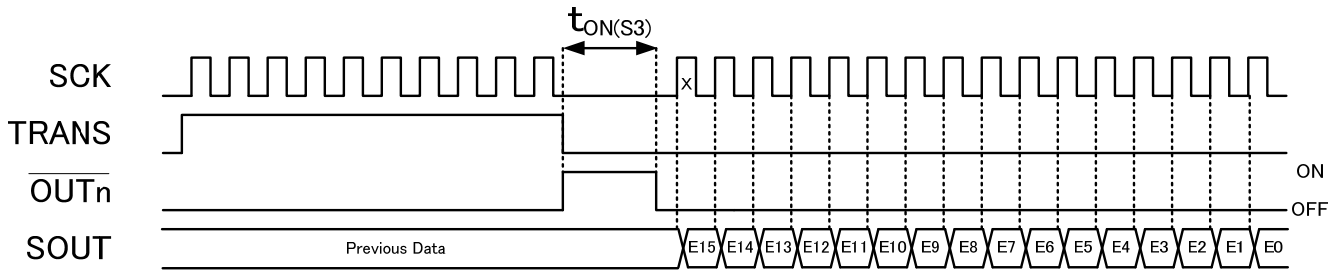

SOUT is operation at the time of S6 command N0=0 conditions.

The first SCK (signal X) after this command is used for transmission of the output open/short detection result data. The input from SIN is not received. Note1

Note1: This operation is performed when the output open/short detection function is "Active" setting.
 The output open/short detection functions are set by S6 command.
 Default setting is "Not Active".

8-5) S4 command (Reset of the internal PWM counter.)

Operation) In the number of SCK pulses at TRANS="H" is 11 or 12, the following operation is executed.
 The internal PWM counter is reset.
 When the internal PWM counter is reset, the output is turned off.

Note) It is necessary to input S1 command to turn on the output again.

Basic input pattern of S4 command)

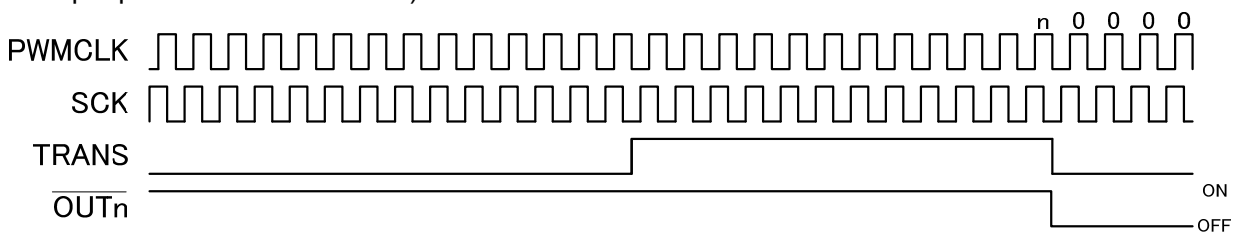

8-6-1) S5 command (Input of the state setting data (1).)

Operation) In the number of SCK pulses at TRANS="H" is 13 or 14, the following operation is executed.
 The state setting data (1) in the 16-bit shift register is transmitted to the state setting register.

Basic input pattern of S5 command)

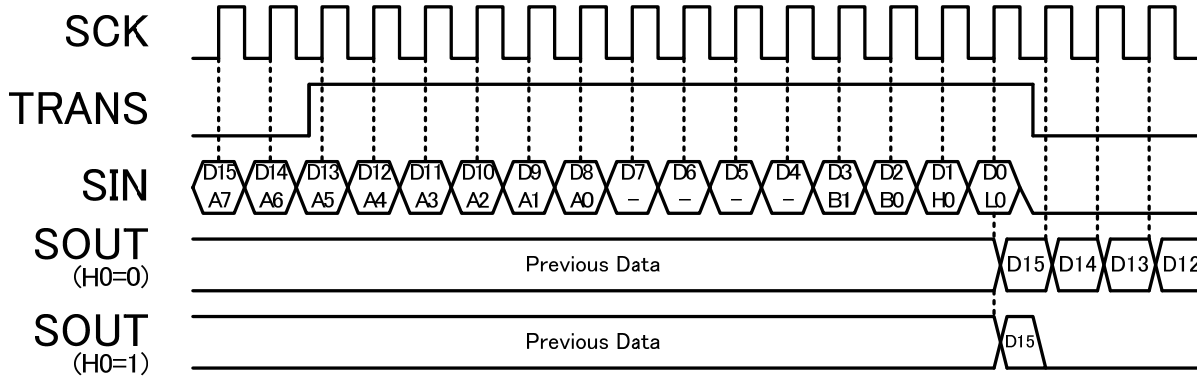

SOUT is operation at the time of S6 command N0=0 conditions.

8-6-2) Input form of the state setting data (1)

MSB														LSB	
D15	D14	D13	D12	D11	D10	D9	D8	D7	D6	D5	D4	D3	D2	D1	D0
A7	A6	A5	A4	A3	A2	A1	A0	-	-	-	-	B1	B0	H0	L0

D15 to D0 is serial-data-inputted at MSB first.
 Please input "L" data to D7 to D4.

The state setting data (1) setting

Setting bit	Outline of command	Input data		(Default)
		0	1	
A7	Setting of output gain control range	High setting mode 47.5% to 202.7%	Low setting mode 8.46% to 43.96%	47.5% to 202.7%
A6 to A0	Setting of output gain control data	Please refer to 14 to 15 page.		100.0%
B1 to B0	Setting of PWM resolution	Please refer to 16 page.		16-bit
H0	Setting of Initialization function	Not Active	Active	Not Active
L0	Setting of standby mode (1) function	Not Active	Active	Not Active

8-6-3) Details of each setting A setting (output gain control data)

1. In the case of the high setting mode (47.5% to 202.7%)

A[6]	A[5]	A[4]	A[3]	A[2]	A[1]	A[0]	Current gain(%)	A[6]	A[5]	A[4]	A[3]	A[2]	A[1]	A[0]	Current gain(%)
1	1	1	1	1	1	1	202.7	0	1	1	1	1	1	1	124.5
1	1	1	1	1	1	0	201.5	0	1	1	1	1	1	0	123.3
1	1	1	1	1	0	1	200.3	0	1	1	1	1	0	1	122.0
1	1	1	1	1	0	0	199.1	0	1	1	1	1	0	0	120.8
1	1	1	1	0	1	1	197.8	0	1	1	1	0	1	1	119.6
1	1	1	1	0	1	0	196.6	0	1	1	1	0	1	0	118.4
1	1	1	1	0	0	1	195.4	0	1	1	1	0	0	1	117.2
1	1	1	1	0	0	0	194.2	0	1	1	1	0	0	0	115.9
1	1	1	0	1	1	1	193.0	0	1	1	0	1	1	1	114.7
1	1	1	0	1	1	0	191.7	0	1	1	0	1	1	0	113.5
1	1	1	0	1	0	1	190.5	0	1	1	0	1	0	1	112.3
1	1	1	0	1	0	0	189.3	0	1	1	0	1	0	0	111.0
1	1	1	0	0	1	1	188.1	0	1	1	0	0	1	1	109.8
1	1	1	0	0	1	0	186.8	0	1	1	0	0	1	0	108.6
1	1	1	0	0	0	1	185.6	0	1	1	0	0	0	1	107.4
1	1	1	0	0	0	0	184.4	0	1	1	0	0	0	0	106.2
1	1	0	1	1	1	1	183.2	0	1	0	1	1	1	1	104.9
1	1	0	1	1	1	0	181.9	0	1	0	1	1	1	0	103.7
1	1	0	1	1	0	1	180.7	0	1	0	1	1	0	1	102.5
1	1	0	1	1	0	0	179.5	0	1	0	1	1	0	0	101.3
1	1	0	1	0	1	1	178.3	0	1	0	1	0	1	1	100.0 (Default)
1	1	0	1	0	1	0	177.1	0	1	0	1	0	1	0	98.8
1	1	0	1	0	0	1	175.8	0	1	0	1	0	0	1	97.6
1	1	0	1	0	0	0	174.6	0	1	0	1	0	0	0	96.4
1	1	0	0	1	1	1	173.4	0	1	0	0	1	1	1	95.2
1	1	0	0	1	1	0	172.2	0	1	0	0	1	1	0	93.9
1	1	0	0	1	0	1	170.9	0	1	0	0	1	0	1	92.7
1	1	0	0	1	0	0	169.7	0	1	0	0	1	0	0	91.5
1	1	0	0	0	1	1	168.5	0	1	0	0	0	1	1	90.3
1	1	0	0	0	1	0	167.3	0	1	0	0	0	1	0	89.0
1	1	0	0	0	0	1	166.1	0	1	0	0	0	0	1	87.8
1	1	0	0	0	0	0	164.8	0	1	0	0	0	0	0	86.6
1	0	1	1	1	1	1	163.6	0	0	1	1	1	1	1	85.4
1	0	1	1	1	1	0	162.4	0	0	1	1	1	1	0	84.2
1	0	1	1	1	0	1	161.2	0	0	1	1	1	0	1	82.9
1	0	1	1	1	0	0	159.9	0	0	1	1	1	0	0	81.7
1	0	1	1	0	1	1	158.7	0	0	1	1	0	1	1	80.5
1	0	1	1	0	1	0	157.5	0	0	1	1	0	1	0	79.3
1	0	1	1	0	0	1	156.3	0	0	1	1	0	0	1	78.0
1	0	1	1	0	0	0	155.1	0	0	1	1	0	0	0	76.8
1	0	1	0	1	1	1	153.8	0	0	1	0	1	1	1	75.6
1	0	1	0	1	1	0	152.6	0	0	1	0	1	1	0	74.4
1	0	1	0	1	0	1	151.4	0	0	1	0	1	0	1	73.2
1	0	1	0	1	0	0	150.2	0	0	1	0	1	0	0	71.9
1	0	1	0	0	1	1	148.9	0	0	1	0	0	1	1	70.7
1	0	1	0	0	1	0	147.7	0	0	1	0	0	1	0	69.5
1	0	1	0	0	0	1	146.5	0	0	1	0	0	0	1	68.3
1	0	1	0	0	0	0	145.3	0	0	1	0	0	0	0	67.0
1	0	0	1	1	1	1	144.1	0	0	0	1	1	1	1	65.8
1	0	0	1	1	1	0	142.8	0	0	0	1	1	1	0	64.6
1	0	0	1	1	0	1	141.6	0	0	0	1	1	0	1	63.4
1	0	0	1	1	0	0	140.4	0	0	0	1	1	0	0	62.1
1	0	0	1	0	1	1	139.2	0	0	0	1	0	1	1	60.9
1	0	0	1	0	1	0	137.9	0	0	0	1	0	1	0	59.7
1	0	0	1	0	0	1	136.7	0	0	0	1	0	0	1	58.5
1	0	0	1	0	0	0	135.5	0	0	0	1	0	0	0	57.3
1	0	0	0	1	1	1	134.3	0	0	0	0	1	1	1	56.0
1	0	0	0	1	1	0	133.1	0	0	0	0	1	1	0	54.8
1	0	0	0	1	0	1	131.8	0	0	0	0	1	0	1	53.6
1	0	0	0	1	0	0	130.6	0	0	0	0	1	0	0	52.4
1	0	0	0	0	1	1	129.4	0	0	0	0	0	1	1	51.1
1	0	0	0	0	0	1	128.2	0	0	0	0	0	1	0	49.9
1	0	0	0	0	0	0	126.9	0	0	0	0	0	0	1	48.7
1	0	0	0	0	0	0	125.7	0	0	0	0	0	0	0	47.5

2. In the case of the low setting mode (8.46% to 43.96%)

A[6]	A[5]	A[4]	A[3]	A[2]	A[1]	A[0]	Current gain(%)	A[6]	A[5]	A[4]	A[3]	A[2]	A[1]	A[0]	Current gain(%)
1	1	1	1	1	1	1	43.96	0	1	1	1	1	1	1	26.07
1	1	1	1	1	1	0	43.68	0	1	1	1	1	1	0	25.79
1	1	1	1	1	0	1	43.40	0	1	1	1	1	0	1	25.51
1	1	1	1	1	0	0	43.12	0	1	1	1	1	0	0	25.23
1	1	1	1	1	0	1	42.84	0	1	1	1	0	1	1	24.95
1	1	1	1	0	1	0	42.56	0	1	1	1	0	1	0	24.67
1	1	1	1	0	0	1	42.28	0	1	1	1	0	0	1	24.39
1	1	1	1	0	0	0	42.00	0	1	1	1	0	0	0	24.11
1	1	1	0	1	1	1	41.72	0	1	1	0	1	1	1	23.83
1	1	1	0	1	1	0	41.44	0	1	1	0	1	1	0	23.55
1	1	1	0	1	0	1	41.16	0	1	1	0	1	0	1	23.27
1	1	1	0	1	0	0	40.89	0	1	1	0	1	0	0	23.00
1	1	1	0	0	1	1	40.61	0	1	1	0	0	1	1	22.72
1	1	1	0	0	1	0	40.33	0	1	1	0	0	1	0	22.44
1	1	1	0	0	0	1	40.05	0	1	1	0	0	0	1	22.16
1	1	1	0	0	0	0	39.77	0	1	1	0	0	0	0	21.88
1	1	0	1	1	1	1	39.49	0	1	0	1	1	1	1	21.60
1	1	0	1	1	1	0	39.21	0	1	0	1	1	1	0	21.32
1	1	0	1	1	0	1	38.93	0	1	0	1	1	0	1	21.04
1	1	0	1	1	0	0	38.65	0	1	0	1	1	0	0	20.76
1	1	0	1	0	1	1	38.37	0	1	0	1	0	1	1	20.48
1	1	0	1	0	1	0	38.09	0	1	0	1	0	1	0	20.20
1	1	0	1	0	0	1	37.81	0	1	0	1	0	0	1	19.92
1	1	0	1	0	0	0	37.53	0	1	0	1	0	0	0	19.64
1	1	0	0	1	1	1	37.25	0	1	0	0	1	1	1	19.36
1	1	0	0	1	1	0	36.97	0	1	0	0	1	1	0	19.08
1	1	0	0	1	0	1	36.69	0	1	0	0	1	0	1	18.80
1	1	0	0	1	0	0	36.41	0	1	0	0	1	0	0	18.52
1	1	0	0	0	1	1	36.13	0	1	0	0	0	1	1	18.24
1	1	0	0	0	1	0	35.85	0	1	0	0	0	1	0	17.96
1	1	0	0	0	0	1	35.57	0	1	0	0	0	0	1	17.68
1	1	0	0	0	0	0	35.29	0	1	0	0	0	0	0	17.40
1	0	1	1	1	1	1	35.02	0	0	1	1	1	1	1	17.13
1	0	1	1	1	1	0	34.74	0	0	1	1	1	1	0	16.85
1	0	1	1	1	0	1	34.46	0	0	1	1	1	0	1	16.57
1	0	1	1	1	0	0	34.18	0	0	1	1	1	0	0	16.29
1	0	1	1	0	1	1	33.90	0	0	1	1	0	1	1	16.01
1	0	1	1	0	1	0	33.62	0	0	1	1	0	1	0	15.73
1	0	1	1	0	0	1	33.34	0	0	1	1	0	0	1	15.45
1	0	1	1	0	0	0	33.06	0	0	1	1	0	0	0	15.17
1	0	1	0	1	1	1	32.78	0	0	1	0	1	1	1	14.89
1	0	1	0	1	1	0	32.50	0	0	1	0	1	1	0	14.61
1	0	1	0	1	0	1	32.22	0	0	1	0	1	0	1	14.33
1	0	1	0	1	0	0	31.94	0	0	1	0	1	0	0	14.05
1	0	1	0	0	1	1	31.66	0	0	1	0	0	1	1	13.77
1	0	1	0	0	1	0	31.38	0	0	1	0	0	1	0	13.49
1	0	1	0	0	0	1	31.10	0	0	1	0	0	0	1	13.21
1	0	1	0	0	0	0	30.82	0	0	1	0	0	0	0	12.93
1	0	0	1	1	1	1	30.54	0	0	0	1	1	1	1	12.65
1	0	0	1	1	1	0	30.26	0	0	0	1	1	1	0	12.37
1	0	0	1	1	0	1	29.98	0	0	0	1	1	0	1	12.09
1	0	0	1	1	0	0	29.70	0	0	0	1	1	0	0	11.81
1	0	0	1	0	1	1	29.42	0	0	0	1	0	1	1	11.53
1	0	0	1	0	1	0	29.15	0	0	0	1	0	1	0	11.26
1	0	0	1	0	0	1	28.87	0	0	0	1	0	0	1	10.98
1	0	0	1	0	0	0	28.59	0	0	0	1	0	0	0	10.70
1	0	0	0	1	1	1	28.31	0	0	0	0	1	1	1	10.42
1	0	0	0	1	1	0	28.03	0	0	0	0	1	1	0	10.14
1	0	0	0	1	0	1	27.75	0	0	0	0	1	0	1	9.86
1	0	0	0	1	0	0	27.47	0	0	0	0	1	0	0	9.58
1	0	0	0	0	1	1	27.19	0	0	0	0	0	1	1	9.30
1	0	0	0	0	1	0	26.91	0	0	0	0	0	1	0	9.02
1	0	0	0	0	0	1	26.63	0	0	0	0	0	0	1	8.74
1	0	0	0	0	0	0	26.35	0	0	0	0	0	0	0	8.46

B setting (Setting of PWM resolution)

B[1]	B[0]	Setting
0	0	16-bit (65536 steps) setting. (Default)
0	1	14-bit (16384 steps) setting.
1	0	12-bit (4096 steps) setting.
1	1	10-bit (1024 steps) setting.

H setting (Setting of Initialization function)

H[0]	Setting
0	The initialization function becomes not active.(Default) It's normal operation mode.
1	The initialization function becomes active. All data in IC is initialized. After data initialization, it becomes normal operation mode.

L setting (Setting of standby mode (1) function)

L[0]	Setting
0	The standby mode (1) function becomes not active. (Default) It's normal operation mode.
1	The standby mode (1) function becomes active. The circuits other than the logic circuit are turned off. And power supply current is reduced. (All the data of the IC are stored. Data input is possible.) When S0 command is inputted at the standby mode, IC returns to normal operation mode. Return time to the normal operation mode is about 30 μ s.

8-7-1) S6 command (Input of the state setting data (2).)

Operation) In the number of SCK pulses at TRANS="H" is 15 or 16, the following operation is executed.
The state setting data (2) in the 16-bit shift register is transmitted to the state setting register.

Basic input pattern of S6 command)

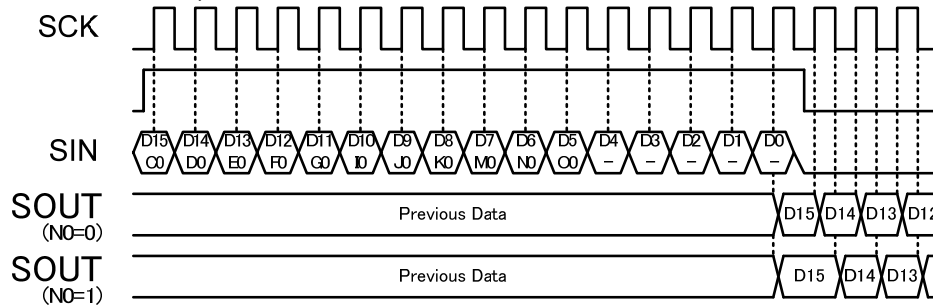

8-7-2) Input form of the state setting data (2)

MSB

LSB

D15	D14	D13	D12	D11	D10	D9	D8	D7	D6	D5	D4	D3	D2	D1	D0
C0	D0	E0	F0	G0	I0	J0	K0	M0	N0	O0	-	-	-	-	-

D15 to D0 is serial-data-inputted at MSB first.

Please input "L" data to D4 to D0.

The state setting data (2) setting

Setting bit	Outline of command	Input data		(Default)
		0	1	
C0	Setting of thermal shutdown function (TSD)	Active	Not Active	Active
D0	Setting of PWMCLK open detection function (POD)	Active	Not Active	Active
E0	Setting of output open detection function (OOD)	Not Active	Active	Not Active
F0	Setting of output short detection function (OSD)	Not Active	Active	Not Active
G0	Setting of PWM output synchronization	Synchronous	Asynchronous	Synchronous
I0	Setting of PWM output system	Normal output	Division output	Normal output
J0	Setting of standby mode (2) function This function becomes active only at the time of the 16-bit PWM setting.	Not Active	Active	Not Active
K0	Setting of output short detection voltage	V _{OSD1}	V _{OSD2}	V _{OSD1}
M0	Setting of output delay function	Active	Not Active	Active
N0	Setting of SCK trigger of SOUT	Up edge trigger mode	Down edge trigger mode	Up edge trigger mode
O0	Setting of PWM output mode	repeat mode	One-shot mode	repeat mode

8-7-3) Details of each setting

C setting (Setting of thermal shutdown function (TSD))

C[0]	Setting
0	Thermal shutdown function becomes active. (Default)
1	Thermal shutdown function becomes not active.

D setting (Setting of PWMCLK open detection function (POD))

D[0]	Setting
0	<p>PWMCLK open detection function becomes active. (Default)</p> <p>When it was the state that a PWMCLK signal isn't input by breaking of wiring, it's the function which prevents PWM output keeping stopping by on state.</p> <p>When PWMCLK is not inputted for about 1 second after it is inputted even once, all output is turned off compulsorily.</p> <p>Output compulsion off is released by the initialization function of S5 command.</p> <p>In addition, the output compulsion off is removed by inputting PWMCLK again.</p>
1	PWMCLK open detection function becomes not active.

E setting (Setting of output open detection function (OOD))

E[0]	Setting
0	Output open detection function becomes not active. (Default)
1	Output open detection function becomes active.

F setting (Setting of output short detection function (OSD))

F[0]	Setting
0	Output short detection function becomes not active. (Default)
1	Output short detection function becomes active.

G setting (Setting of PWM output synchronization)

G[0]	Setting
0	PWM output synchronous mode. (Default)
1	PWM output asynchronous mode.

I setting (Setting of PWM output system)

I[0]	Setting
0	Normal PWM output mode. (Default)
1	Division PWM output mode.

J setting (Setting of standby mode (2))

J[0]	Setting
0	The standby mode (2) function becomes not active. (Default) It's normal operation mode.
1	The standby mode (2) function becomes active. A state changes according to the data in a PWM data register. Condition 1: All data in the PWM data register1 and the PWM data register3 are "L". It becomes standby mode. The circuits other than the logic circuit are turned off. And power supply current is reduced. (All the data of the IC are stored. Data input is possible.) Condition 2: Excluding condition 1. It becomes Pre standby mode. It is the same operation as normal operation mode. Return time from standby mode to Pre standby mode is about 30 μs. This function becomes active only at the time of the 16-bit PWM setting.

K setting (Setting of output short detection voltage)

K[0]	Setting
0	V_{OSD1} setting. (Default)
1	V _{OSD2} setting.

M setting (Setting of output delay function)

M[0]	Setting
0	Output delay function becomes active. (Default)
1	Output delay function becomes not active.

N setting (Setting of SCK trigger of SOUT)

N[0]	Setting
0	It becomes up edge trigger mode. (Default) Data output trigger from SOUT, becomes up edge of SCK
1	It becomes down edge trigger mode. Data output trigger from SOUT, becomes down edge of SCK

O setting (Setting of PWM output mode)

O[0]	Setting
0	It becomes repeat PWM output mode. (Default) In the input of this command, PWM output is output repeatedly. In order to stop a PWM output, the input of a reset command is required.
1	It becomes one-shot PWM output mode. In the input of this command, the PWM output is turned on once. When restarting by same PWM data, please input this command again.

9. Input of PWM setting data

9-1) Normal input mode (S0 command: 16 times)

It commands the PWM data input only.

The PWM data for $\overline{OUT0}$ to $\overline{OUT15}$ are transferred to the PWM data register by repeating the PWM data input to the 16-bit shift register and S0 command input 16 times.

Unless S1 command is input, the PWM data for $\overline{OUT0}$ to $\overline{OUT15}$ is not reflected on output.

Normal input mode) S0 command 16 times

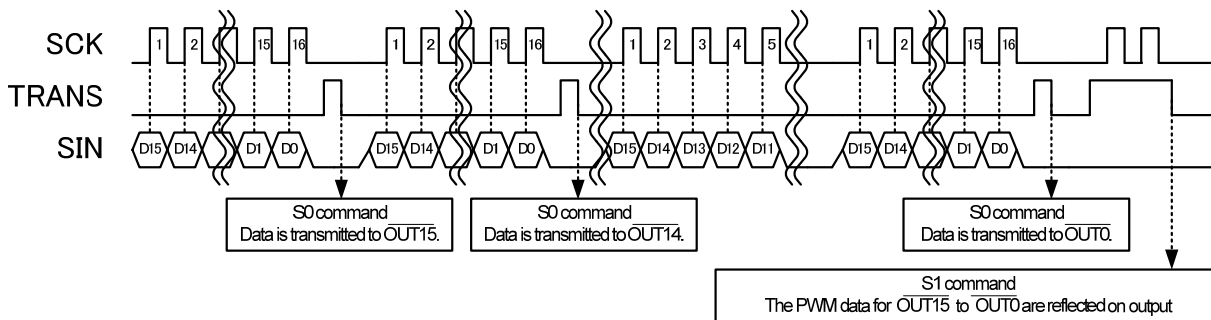

9-2) Speed input mode (S0 command 15 times + S1 command once)

It commands PWM data input and reflecting the PWM data on output at the same time.

The PWM data for $\overline{OUT0}$ to $\overline{OUT15}$ are reflected in the output by inputting S1 command after repeating the PWM data input to the 16-bit shift register and S0 command input 15 times.

Normal input mode should be used to input PWM data only.

Speed input mode) S0 command 15 times + S1 command once

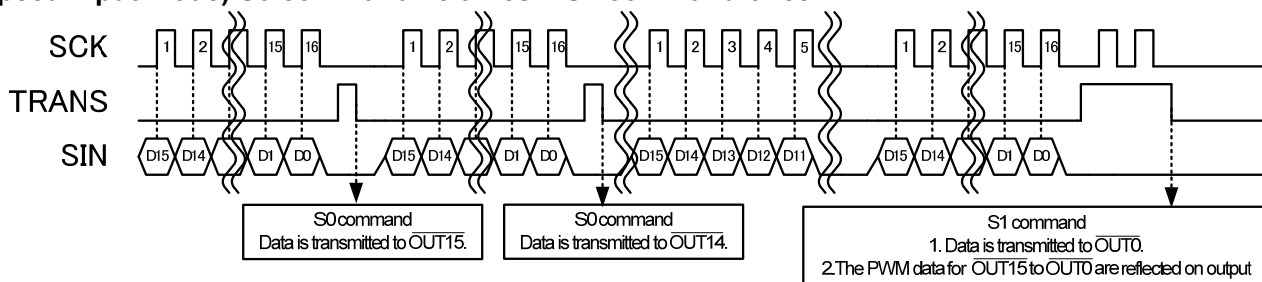

10. About PWM output synchronization

When S1 command is inputted during a PWM output by PWM output asynchronous mode, the present PWM output is canceled and a PWM output is immediately started by new PWM data.

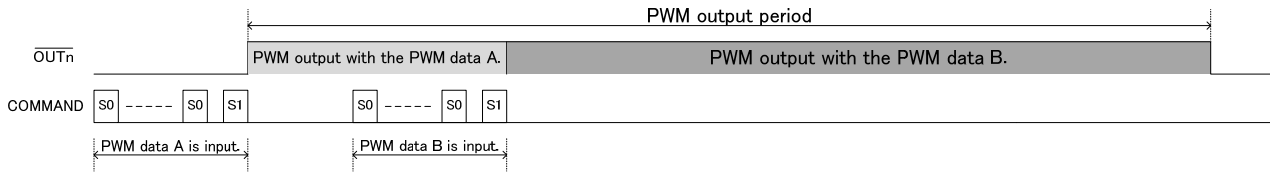

When S1 command is inputted during a PWM output by PWM output synchronous mode, after the present PWM output has ended, a PWM output is started by new PWM data.

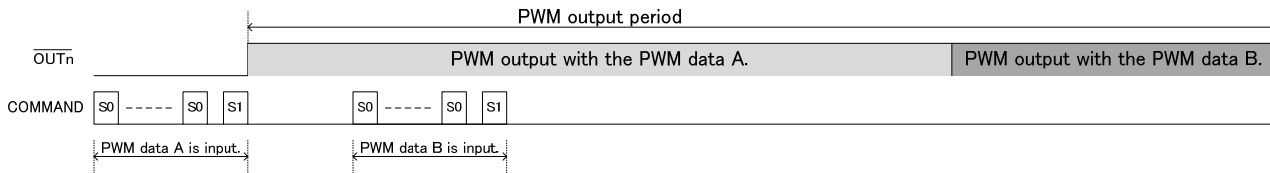

If S1 command is inputted two or more times during a PWM output by PWM output synchronous mode, after the present PWM output has ended, a PWM output will be started by the PWM data inputted at the end.

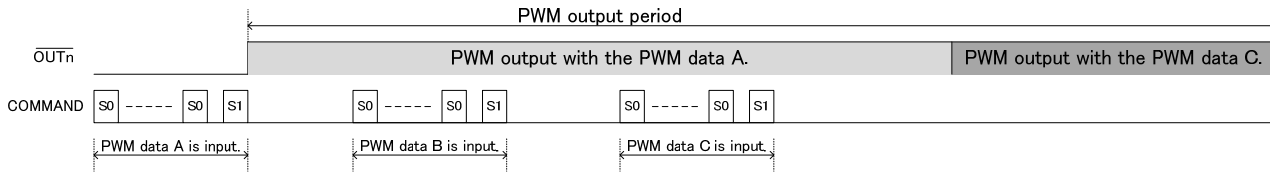

11. About PWM Output system

11-1) Normal PWM output mode.

Output waveform of 16-bit PWM. ($\overline{\text{OUTn}}$ is current waveform)

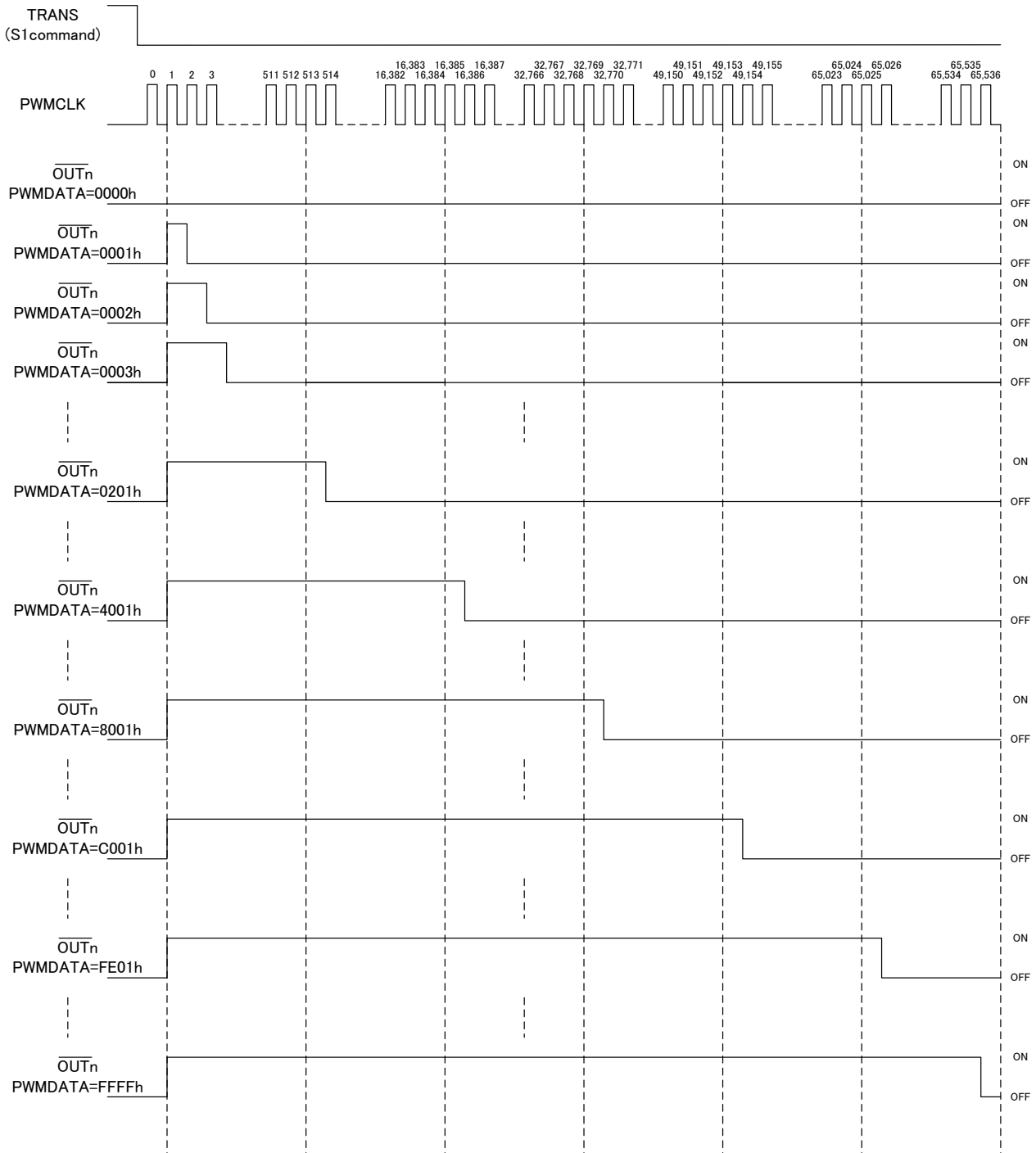

11-2) Division PWM output mode.

PWM output period is divided into 128 pieces.

Because turn on time of output is not biased, it is effective in the flicker prevention on the display.

Output waveform of 16-bit PWM. ($\overline{\text{OUTn}}$ is current waveform)

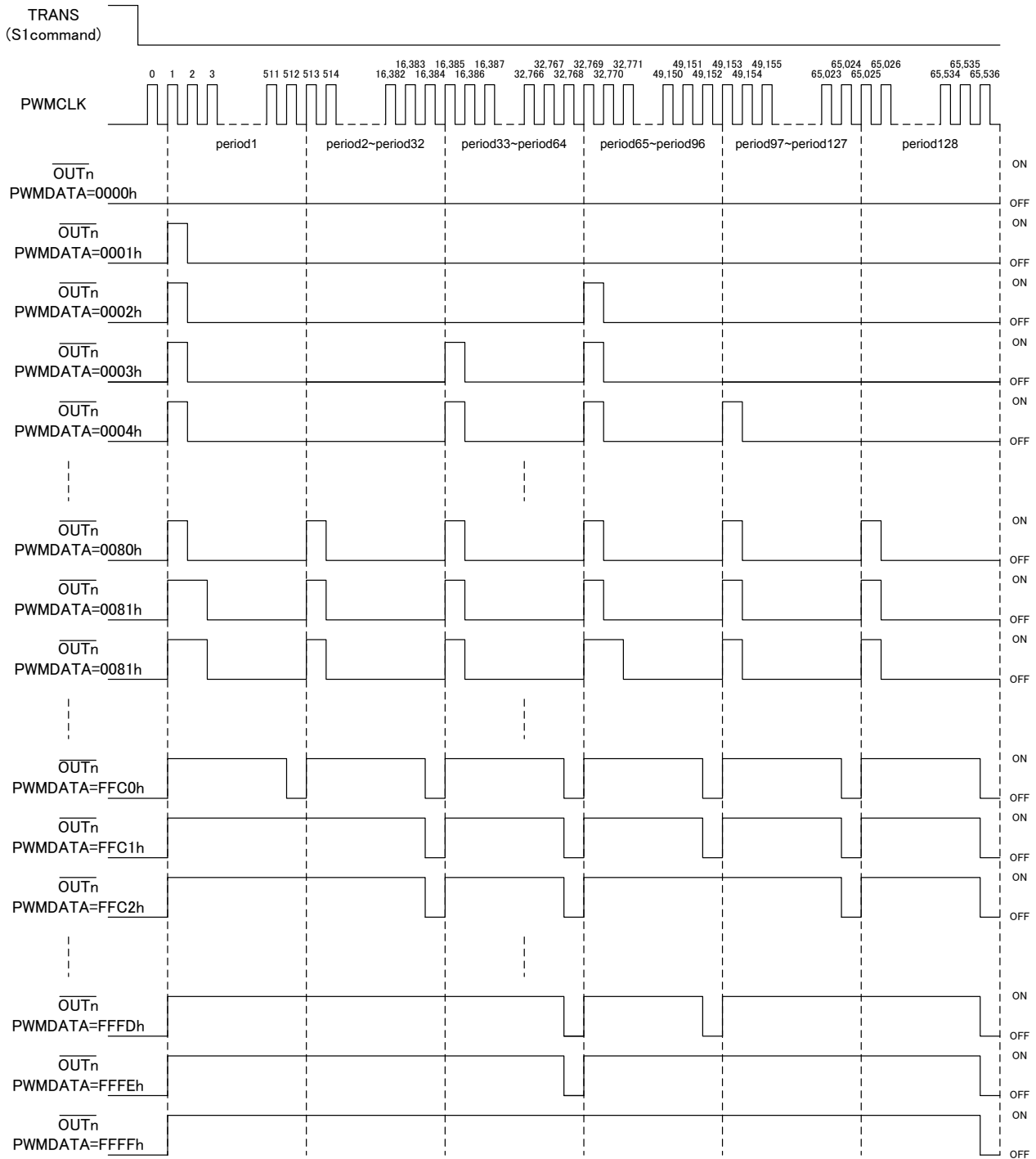

12. About PWM Output mode

12-1) Repeat PWM output mode

In the input of this command, PWM output is output repeatedly.
 In order to stop a PWM output, the input of a reset command is required.

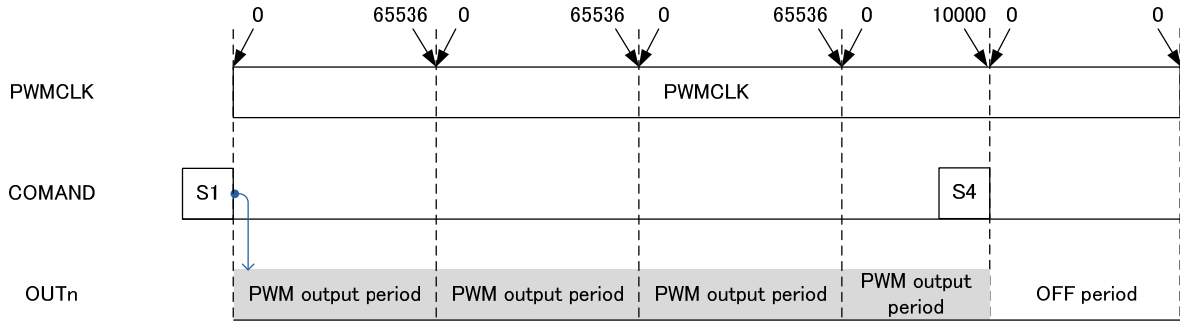

12-2) One-shot PWM output mode

In the input of this command, the PWM output is turned on once.

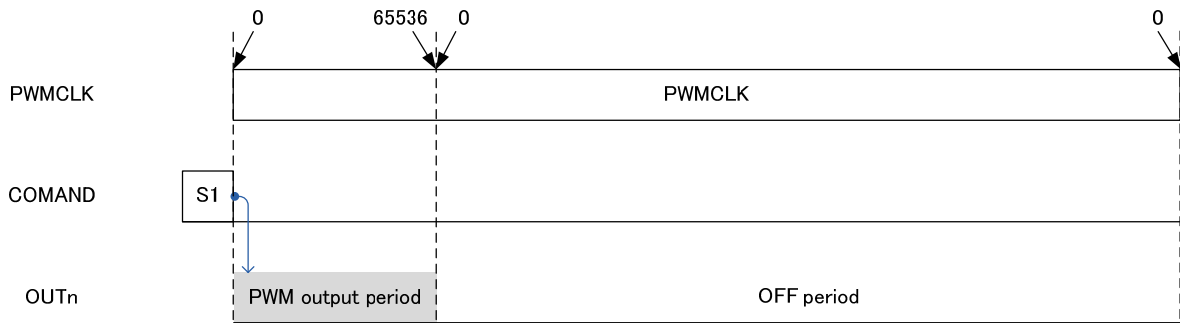

When restarting by same PWM data, please input this command again.

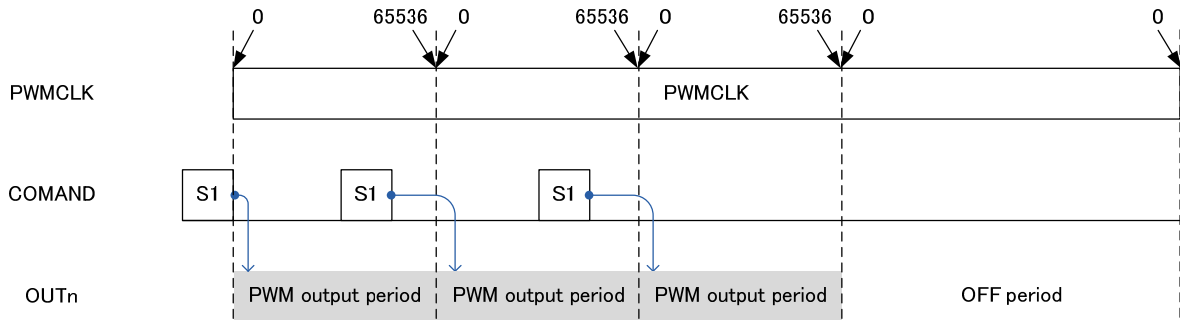

13. Thermal shutdown circuit (TSD)

When the temperature of internal IC exceeds 150°C, all constant current outputs are turned off by this function. The constant current is outputted again when the temperature decreases to the rating.

The thermal shutdown function of this IC aims at stopping the influence (emitting smoke, ignition) on the circumference (LED and substrate) to the minimum, when it is used on the conditions beyond not a function but the absolute maximum rating for preventing destruction of IC and IC results in destruction.

Calculation of heat

Take care not to let the temperature of the internal IC exceed 150°C by referring to the formula below.

$$\text{Consumption power (IC output) [W]} = (\text{LED supply voltage [V]} - \text{Minimum of } V_f \text{ of LED [V]}) \times \text{Output current [A]} \times \text{number of output} \times (\text{ON Duty [\%]} / 100)$$

$$\text{Consumption power (IC supply) [W]} = \text{IC supply voltage [V]} \times \text{IC supply current [A]}$$

$$\text{Total of consumption power [W]} = \text{Consumption power (IC output) [W]} + \text{Consumption power (IC supply) [W]}$$

$$\text{Heat value of internal IC [}^\circ\text{C]} = \text{Thermal Resistance [}^\circ\text{C / W]} \times \text{total of power consumption [W]}$$

$$\text{Temperature of internal IC [}^\circ\text{C]} = \text{Heat value of internal IC [}^\circ\text{C]} + \text{Ambient temperature [}^\circ\text{C]}$$

In case used LED supply voltage is high, and heat value of internal IC is large.

Heat value of internal IC can be reduced by decreasing the voltage with the external resistance shown below.

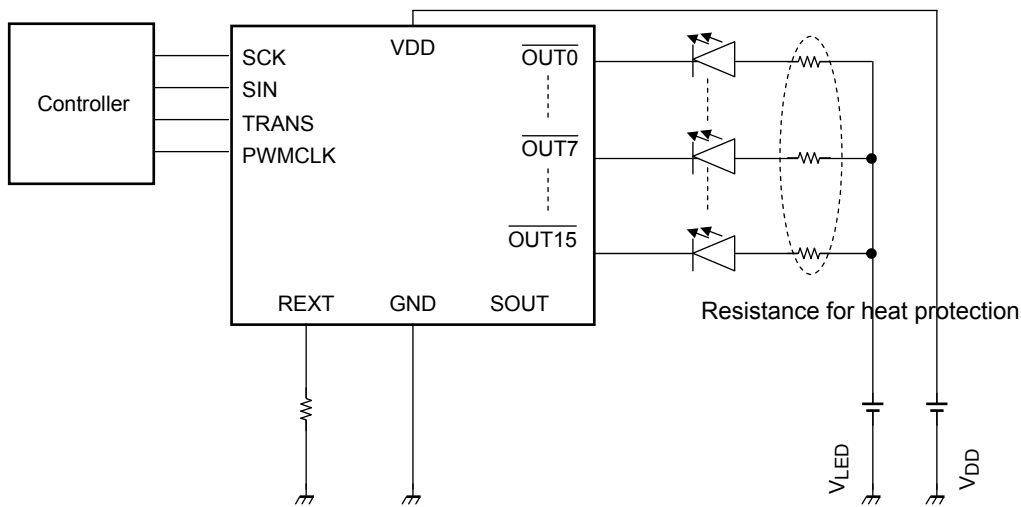

Setting method of resistance for heat protection

Voltage that should decrease by external resistance [V]

$$= \text{LED supply voltage [V]} - \text{maximum of } V_f \text{ of LED [V]} - \text{Output voltage [V]}$$

$$\text{Resistance for heat protection } [\Omega] = \text{Voltage that should decrease by external resistance [V]} / \text{Output current [A]}$$

14. Output delay function

This function is intended to have the effect of reducing switching noise by reducing the di/dt when all outputs are ON or OFF at the same time. There is a switching time lag between outputs.

A switching time lag between outputs is put in order of the following.

- $\overline{\text{OUT0}} \rightarrow \overline{\text{OUT15}} \rightarrow \overline{\text{OUT7}} \rightarrow \overline{\text{OUT8}} \rightarrow \overline{\text{OUT1}} \rightarrow \overline{\text{OUT14}} \rightarrow \overline{\text{OUT6}} \rightarrow \overline{\text{OUT9}} \rightarrow \overline{\text{OUT2}} \rightarrow \overline{\text{OUT13}} \rightarrow \overline{\text{OUT5}} \rightarrow$
 $\overline{\text{OUT10}} \rightarrow \overline{\text{OUT3}} \rightarrow \overline{\text{OUT12}} \rightarrow \overline{\text{OUT4}} \rightarrow \overline{\text{OUT11}}$

15. Power on reset (POR)

It avoids the malfunction by resetting all internal data of IC and setting default in startup.
 POR circuit operates only when V_{DD} rises from 0 V. To restart POR, V_{DD} should be 0.1 V or less.
 As for the voltage of storing the internal data, it is guaranteed after V_{DD} reaches 3.0 V or more once.

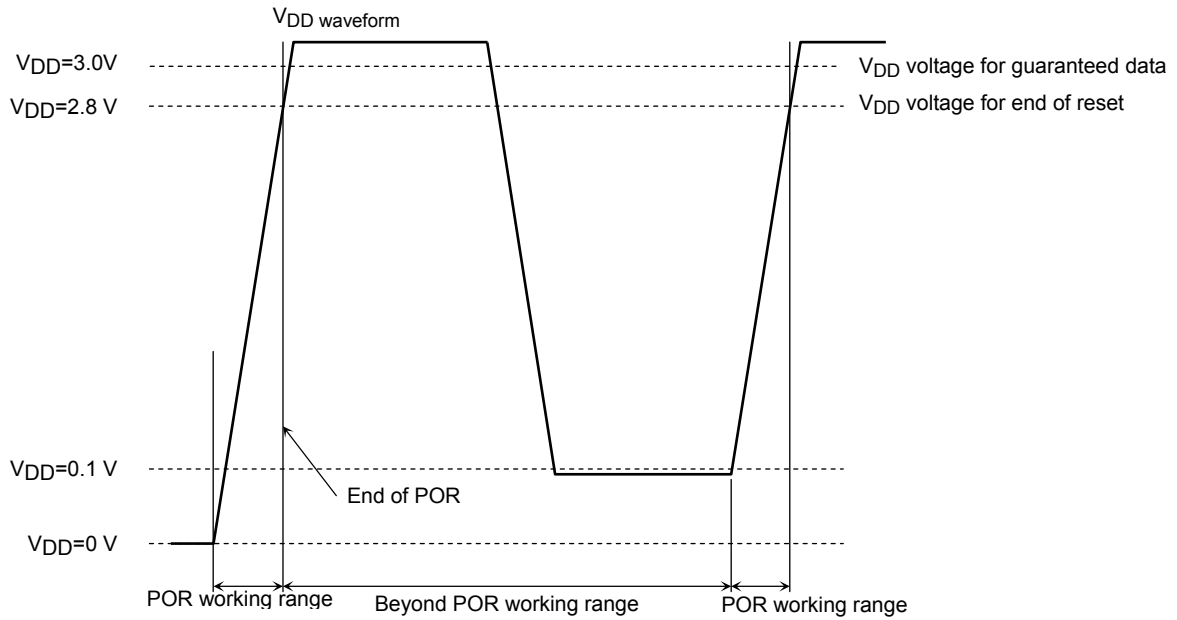

16.Application circuit (Dynamic lighting)

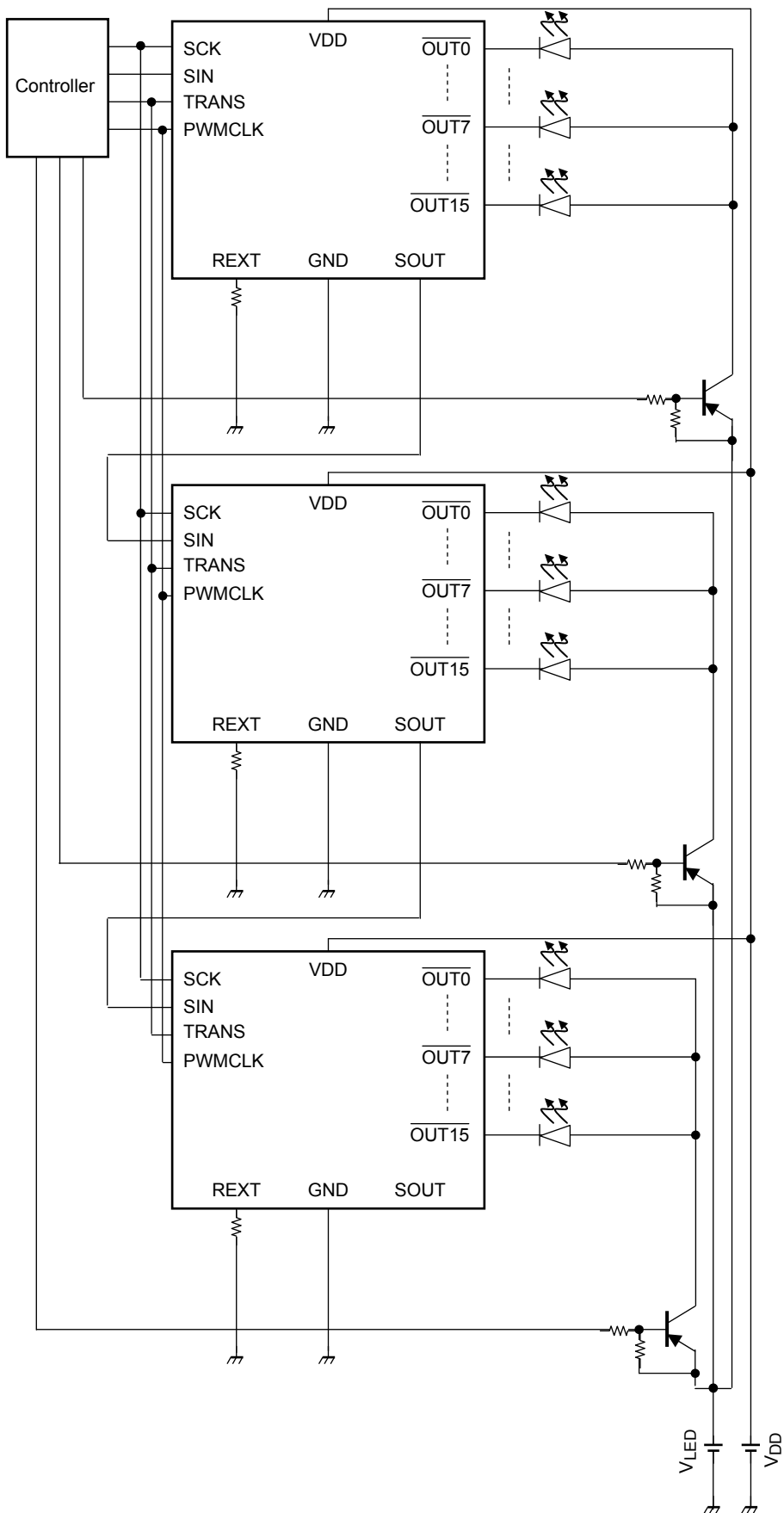

17. Absolute Maximum Ratings (T_a = 25°C)

Characteristics	Symbol	Rating Note1	Unit
S u p p l y v o l t a g e	V _{DD}	-0.3 to 6.0	V
O u t p u t c u r r e n t	I _{OUT}	95	mA
L o g i c i n p u t v o l t a g e	V _{IN}	-0.3 to V _{DD} + 0.3 Note2	V
O u t p u t v o l t a g e	V _{OUT}	-0.3 to 17	V
O p e r a t i n g t e m p e r a t u r e	T _{opr}	-40 to 85	°C
S t o r a g e t e m p e r a t u r e	T _{stg}	-55 to 150	°C
T h e r m a l r e s i s t a n c e	R _{th(j-a)}	45.47 Note3	°C/W
P o w e r d i s s i p a t i o n	P _D	2.74 Note4	W

Note1: Voltage is ground referenced.

Note2: 6V must not be exceeded.

Note3: PCB condition is JEDEC 2s2p

Note4: When ambient temperature is 25°C or more. Every time ambient temperature exceeded 1°C, please decrease 1/R_{th(j-a)}.

18. Operating Condition

18-1) DC Characteristics (Unless otherwise noted, T_a = -40 to 85 °C, V_{DD}=3.0 V to 5.5 V)

Characteristics	Symbol	Test Conditions	Min	Typ.	Max	Unit
S u p p l y v o l t a g e	V _{DD}	—	3.0	—	5.5	V
High level logic input voltage	V _{IH}	Test terminal is SIN, SCK, TRANS, PWMCLK	0.7×V _{DD}	—	V _{DD}	V
Low level logic input voltage	V _{IL}	Test terminal is SIN, SCK, TRANS, PWMCLK	GND	—	0.3×V _{DD}	V
High level SOUT output current	I _{OH}	—	—	—	-1	mA
Low level SOUT output current	I _{OL}	—	—	—	1	mA
Constant current output	I _{OUT}	Test terminal is $\overline{\text{OUTn}}$	1.5	—	90	mA

18-2)AC Characteristics 1 (Unless otherwise noted, T_a = 25 °C, V_{DD} = 5.0 V)

Characteristics	Symbol	Test Conditions		Min	Typ.	Max	Unit
Serial data transfer frequency	f _{SCK}	Up edge trigger mode	Cascade connect	—	—	30	MHz
		Down edge trigger mode		—	—	25	
SCK pulse width	t _{WSCK}	SCK="H" or "L"		15	20	—	ns
PWMCLK pulse width	t _{WPWM}	PWM="H" or "L", R _{EXT} =200 Ω to 12 kΩ		15	20	—	ns
TRANS pulse width	t _{WTRANS}	TRANS="H"		20	—	—	ns
Serial data setup time	t _{SETUP1}	SIN-SCK		1	—	—	ns
	t _{SETUP2}	TRANS-SCK		5	—	—	
	t _{SETUP3}	TRANS-PWMCLK		5	—	—	
Serial data hold time	t _{HOLD1}	SIN-SCK		3	—	—	ns
	t _{HOLD2}	TRANS-SCK		7	—	—	
	t _{HOLD3}	TRANS-PWMCLK		5	—	—	

18-3)AC Characteristics 2 (Unless otherwise noted, T_a = 25 °C, V_{DD} = 3.3 V)

Characteristics	Symbol	Test Conditions		Min	Typ.	Max	Unit
Serial data transfer frequency	f _{SCK}	Up edge trigger mode	Cascade connect	—	—	30	MHz
		Down edge trigger mode		—	—	25	
SCK pulse width	t _{WSCK}	SCK="H" or "L"		15	20	—	ns
PWMCLK pulse width	t _{WPWM}	PWM="H" or "L", R _{EXT} =200 Ω to 12 kΩ		15	20	—	ns
TRANS pulse width	t _{WTRANS}	TRANS="H"		20	—	—	ns
Serial data setup time	t _{SETUP1}	SIN-SCK		1	—	—	ns
	t _{SETUP2}	TRANS-SCK		5	—	—	
	t _{SETUP3}	TRANS-PWMCLK		5	—	—	
Serial data hold time	t _{HOLD1}	SIN-SCK		3	—	—	ns
	t _{HOLD2}	TRANS-SCK		7	—	—	
	t _{HOLD3}	TRANS-PWMCLK		5	—	—	

19. Electrical Characteristics

19-1) Electrical Characteristics 1 (Unless otherwise noted, $T_a = 25\text{ }^\circ\text{C}$, $V_{DD} = 5.0\text{ V}$)

Characteristics	Symbol	Test Circuit	Test Conditions	Min	Typ.	Max	Unit	
High level SOUT output voltage	V_{OH}	1	$T_a = -40\text{ to }+85\text{ }^\circ\text{C}$	$I_{OH} = -1\text{ mA}$	$V_{DD} - 0.3$	—	V_{DD}	V
Low level SOUT output voltage	V_{OL}	1		$I_{OL} = +1\text{ mA}$	GND	—	0.3	V
High level logic input current	I_{IH}	2	$V_{IN} = V_{DD}$ Test terminal is SIN, SCK	—	—	1	μA	
Low level logic input current	I_{IL}	3	$V_{IN} = \text{GND}$ Test terminal is PWMCLK, SIN, SCK, TRANS	—	—	-1	μA	
Power supply current	I_{DD1}	4	Stand-by mode, $V_{OUT} = 17\text{ V}$, SCK="L"	—	—	1.0	μA	
	I_{DD2}	4	$V_{OUT} = 1.0\text{ V}$, $R_{EXT} = 1.2\text{ k}\Omega$, All output off	—	—	7.0	mA	
Constant current error(IC to IC) (S rank)	$\Delta I_{OUT(IC)}$	5	$V_{OUT} = 1.0\text{ V}$, $R_{EXT} = 1.2\text{ k}\Omega$ $\overline{\text{OUT0}}$ to $\overline{\text{OUT15}}$, 1ch output on	—	± 1.0	± 1.5	%	
Constant current error(Ch to Ch) (S rank)	$\Delta I_{OUT(Ch)}$	5	$V_{OUT} = 1.0\text{ V}$, $R_{EXT} = 1.2\text{ k}\Omega$ $\overline{\text{OUT0}}$ to $\overline{\text{OUT15}}$, 1ch output on	—	± 1.0	± 1.5	%	
Constant current error(IC to IC) (N rank)	$\Delta I_{OUT(IC)}$	5	$V_{OUT} = 1.0\text{ V}$, $R_{EXT} = 1.2\text{ k}\Omega$ $\overline{\text{OUT0}}$ to $\overline{\text{OUT15}}$, 1ch output on	—	± 1.0	± 2.5	%	
Constant current error(Ch to Ch) (N rank)	$\Delta I_{OUT(Ch)}$	5	$V_{OUT} = 1.0\text{ V}$, $R_{EXT} = 1.2\text{ k}\Omega$ $\overline{\text{OUT0}}$ to $\overline{\text{OUT15}}$, 1ch output on	—	± 1.0	± 2.5	%	
Output OFF leak current	I_{OK}	5	$V_{OUT} = 17\text{ V}$, $R_{EXT} = 1.2\text{ k}\Omega$, $\overline{\text{OUTn}}$ off	—	—	0.5	μA	
Constant current output power supply voltage regulation	$\%V_{DD}$	5	$V_{DD} = 4.5\text{ to }5.5\text{ V}$, $V_{OUT} = 1.0\text{ V}$, $R_{EXT} = 1.2\text{ k}\Omega$, $\overline{\text{OUT0}}$ to $\overline{\text{OUT15}}$, 1ch output on	—	± 1	± 5	$\%/V$	
Constant current output output voltage regulation	$\%V_{OUT}$	5	$V_{OUT} = 1.0\text{ to }3.0\text{ V}$, $R_{EXT} = 1.2\text{ k}\Omega$, $\overline{\text{OUT0}}$ to $\overline{\text{OUT15}}$, 1ch output on	—	± 0.1	± 0.5	$\%/V$	
Pull-down resistor	R_{DOWN}	2	Test terminal is PWMCLK, TRANS	250	500	750	$\text{k}\Omega$	
O O D voltage	V_{OOD}	6	$R_{EXT} = 200\Omega\text{ to }12\text{ k}\Omega$	0.2	0.3	0.4	V	
O S D voltage	V_{OSD1}	6	$R_{EXT} = 200\Omega\text{ to }12\text{ k}\Omega$	$V_{DD} - 1.3$	$V_{DD} - 1.4$	$V_{DD} - 1.5$	V	
	V_{OSD2}	6	$R_{EXT} = 200\Omega\text{ to }12\text{ k}\Omega$	$0.5 \times V_{DD}$	$0.525 \times V_{DD}$	$0.55 \times V_{DD}$		
TSD start temperature	$T_{TSD(ON)}$	—	Junction temperature	150	—	—	$^\circ\text{C}$	
TSD release temperature	$T_{TSD(OFF)}$	—	Junction temperature	100	—	—	$^\circ\text{C}$	

19-2)Electrical Characteristics 2 (Unless otherwise noted, T_a = 25 °C, V_{DD} = 3.3 V)

Characteristics	Symbol	Test Circuit	Test Conditions	Min	Typ.	Max	Unit
H i g h l e v e l S O U T o u t p u t v o l t a g e	V _{OH}	1	T _a =-40 to +85°C	I _{OH} =-1mA	—	V _{DD} - 0.3	V
L o w l e v e l S O U T o u t p u t v o l t a g e	V _{OL}	1					
High level logic input current	I _{IH}	2	V _{IN} = V _{DD} Test terminal is SIN, SCK	—	—	1	μA
Low level logic input current	I _{IL}	3	V _{IN} = GND Test terminal is PWMCLK, SIN, SCK, TRANS	—	—	-1	μA
Power supply current	I _{DD1}	4	Stand-by mode, V _{OUT} =17V, SCK="L"	—	—	1.0	μA
	I _{DD2}	4	V _{OUT} =1.0V, R _{EXT} =1.2kΩ, All output off	—	—	7.0	mA
Constant current error(IC to IC) (S rank)	ΔI _{OUT(IC)}	5	V _{OUT} =1.0V, R _{EXT} =1.2kΩ OUT0 to OUT15, 1ch output on	—	±1.0	±1.5	%
Constant current error(Ch to Ch) (S rank)	ΔI _{OUT(Ch)}	5	V _{OUT} =1.0V, R _{EXT} =1.2kΩ OUT0 to OUT15, 1ch output on	—	±1.0	±1.5	%
Constant current error(IC to IC) (N rank)	ΔI _{OUT(IC)}	5	V _{OUT} =1.0V, R _{EXT} =1.2kΩ OUT0 to OUT15, 1ch output on	—	±1.0	±2.5	%
Constant current error(Ch to Ch) (N rank)	ΔI _{OUT(Ch)}	5	V _{OUT} =1.0V, R _{EXT} =1.2kΩ OUT0 to OUT15, 1ch output on	—	±1.0	±2.5	%
Output OFF leak current	I _{OK}	5	V _{OUT} =17V, R _{EXT} =1.2kΩ, OUTn off	—	—	0.5	μA
Constant current output power supply voltage regulation	%V _{DD}	5	V _{DD} =3.0 to 3.6V, V _{OUT} =1.0V, R _{EXT} =1.2kΩ, OUT0 to OUT15, 1ch output on	—	±1	±5	%/V
Constant current output output voltage regulation	%V _{OUT}	5	V _{OUT} =1.0 to 3.0V, R _{EXT} =1.2kΩ, OUT0 to OUT15, 1ch output on	—	±0.1	±0.5	%/V
P u l l - d o w n r e s i s t o r	R _{DOWN}	2	Test terminal is PWMCLK, TRANS	250	500	750	kΩ
O O D v o l t a g e	V _{OOD}	6	R _{EXT} =200Ω to 12kΩ	0.2	0.3	0.4	V
O S D v o l t a g e	V _{OSD1}	6	R _{EXT} =200Ω to 12kΩ	V _{DD} - 1.3	V _{DD} - 1.4	V _{DD} - 1.5	V
	V _{OSD2}	6	R _{EXT} =200Ω to 12kΩ	0.5 × V _{DD}	0.525 × V _{DD}	0.55 × V _{DD}	
TSD start temperature	T _{TDS(ON)}	—	Junction temperature	150	—	—	°C
TSD release temperature	T _{TSD(OFF)}	—	Junction temperature	100	—	—	°C

20.Switching Characteristics

20-1)Switching Characteristics 1 (Unless otherwise specified, $T_a = 25\text{ }^\circ\text{C}$, $V_{DD} = 5.0\text{ V}$)

Characteristics		Symbol	Test Circuit	Test Conditions	Min	Typ.	Max	Unit
Propagation delay	SCK↑-SOUT	t_{PD1U}	7	Up edge trigger mode	6	16	30	ns
	SCK↓-SOUT	t_{PD1D}	7	Down edge trigger mode	2	10	14	
	PWMCLK- $\overline{\text{OUT0}}$	t_{PD2}	7	$R_{EXT}=1.2k\Omega$	—	30	40	
Constant current output rise time		t_{or}	7	10 to 90% at voltage waveform of $\overline{\text{OUTn}}$ $R_{EXT}=1.2k\Omega$	—	10	20	ns
Constant current output fall time		t_{of}	7	90 to 10% at voltage waveform of $\overline{\text{OUTn}}$ $R_{EXT}=1.2k\Omega$	—	10	20	ns
Constant current output delay time		$t_{DLY(ON)}$	7	$R_{EXT}=1.2k\Omega$	1	4	9	ns
		$t_{DLY(OFF)}$	7	$R_{EXT}=1.2k\Omega$	1	4	9	ns

20-2)Switching Characteristics 2 (Unless otherwise specified, $V_{DD} = 3.3\text{ V}$, $T_a = 25\text{ }^\circ\text{C}$)

Characteristics		Symbol	Test Circuit	Test Conditions	Min	Typ.	Max	Unit
Propagation delay	SCK↑-SOUT	t_{PD1U}	7	Up edge trigger mode	6	16	30	ns
	SCK↓-SOUT	t_{PD1D}	7	Down edge trigger mode	2	13	18	
	PWMCLK- $\overline{\text{OUT0}}$	t_{PD2}	7	$R_{EXT}=1.2k\Omega$	—	30	40	
Constant current output rise time		t_{or}	7	10 to 90% at voltage waveform of $\overline{\text{OUTn}}$ $R_{EXT}=1.2k\Omega$	—	10	20	ns
Constant current output fall time		t_{of}	7	90 to 10% at voltage waveform of $\overline{\text{OUTn}}$ $R_{EXT}=1.2k\Omega$	—	10	20	ns
Constant current output delay time		$t_{DLY(ON)}$	7	$R_{EXT}=1.2k\Omega$	2	6	12	ns
		$t_{DLY(OFF)}$	7	$R_{EXT}=1.2k\Omega$	2	6	12	ns

21. Test circuit

Test circuit 1 : High level SOUT output voltage / Low level SOUT output voltage

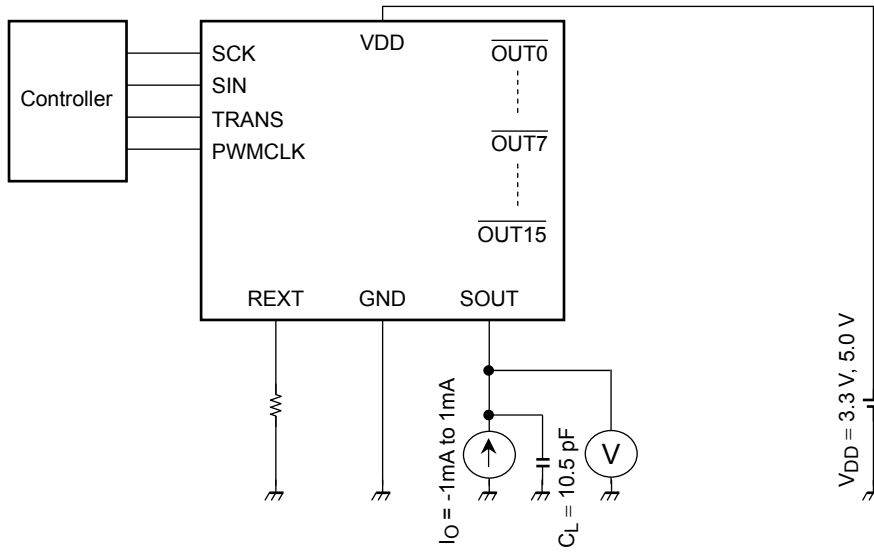

Test circuit 2 : High level logic input current / Pull-down resistance

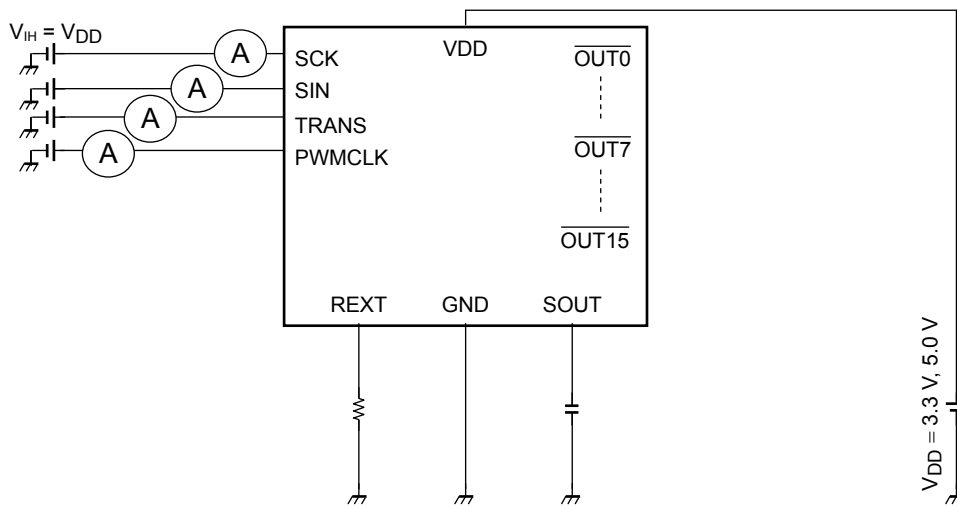

Test circuit 3 : Low level logic input current

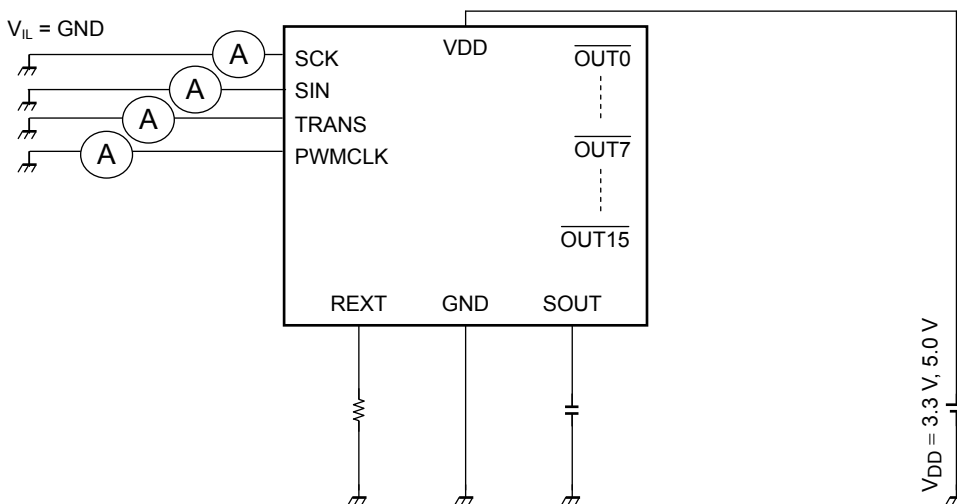

Test circuit 4 : Power supply current

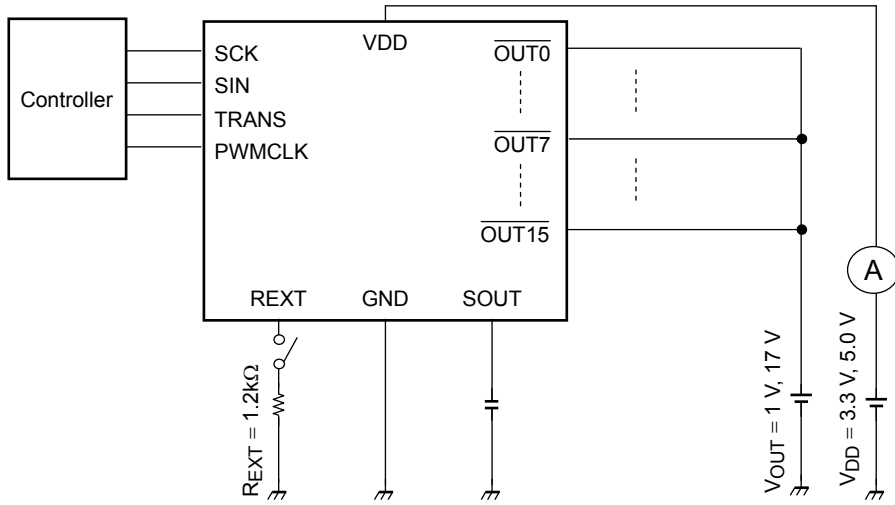

Test circuit 5 : Constant current error / Output OFF leak current
 Constant current output power supply voltage regulation
 Constant current output output voltage regulation

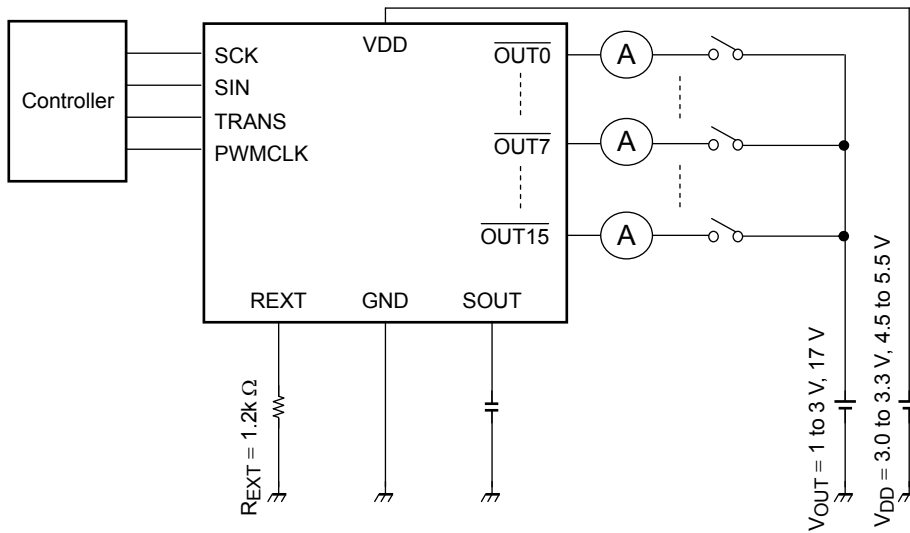

Test Circuit 6 : OOD voltage / OSD voltage

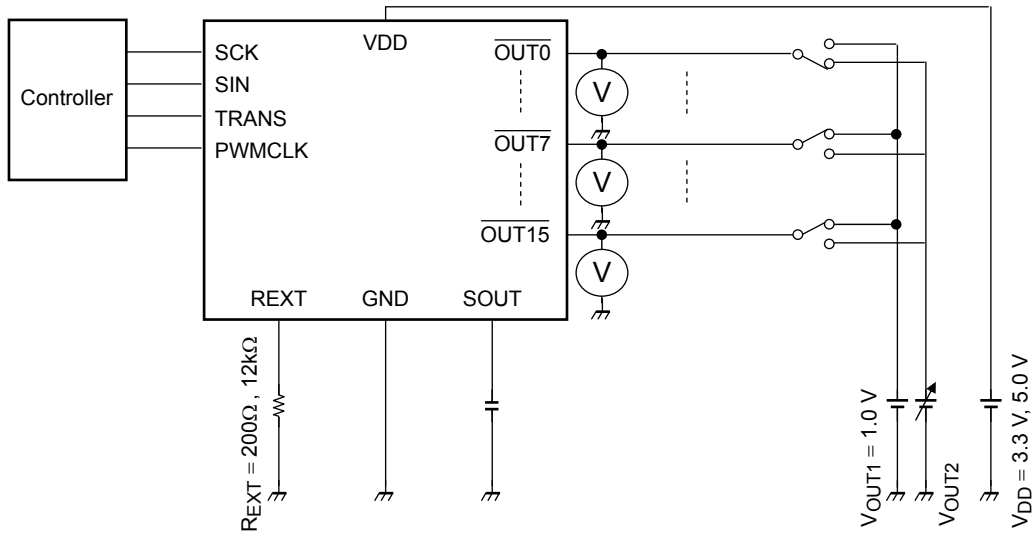

All output is set to turning on. Only one output is connected with the V_{OUT2} power supply, and other outputs are connected with the V_{OUT1} power supply. V_{OUT2} is changed and V_{OOD}/V_{OSD} is checked in the error detection result from each output terminal voltage and SOUT.

Test Circuit 7 : Switching Characteristics

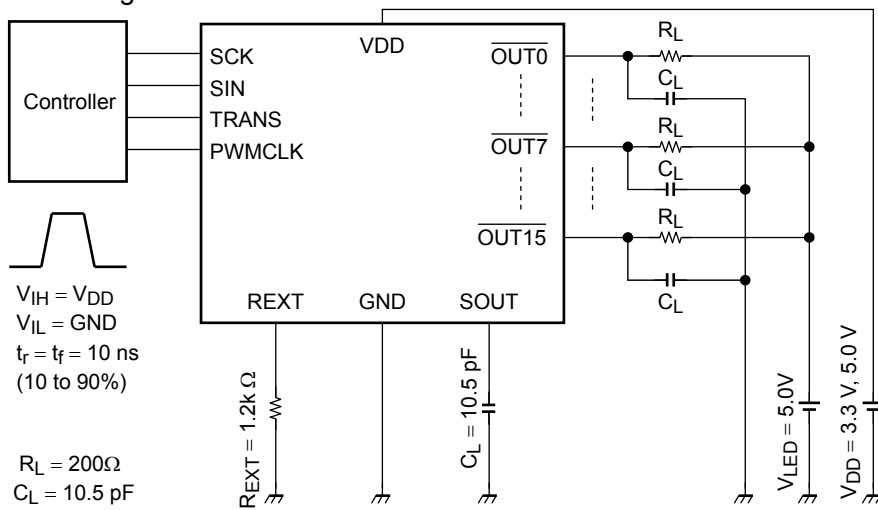

22. Timing waveform

22-1) SCK, TRANS, SIN, SOUT, PWMCLK

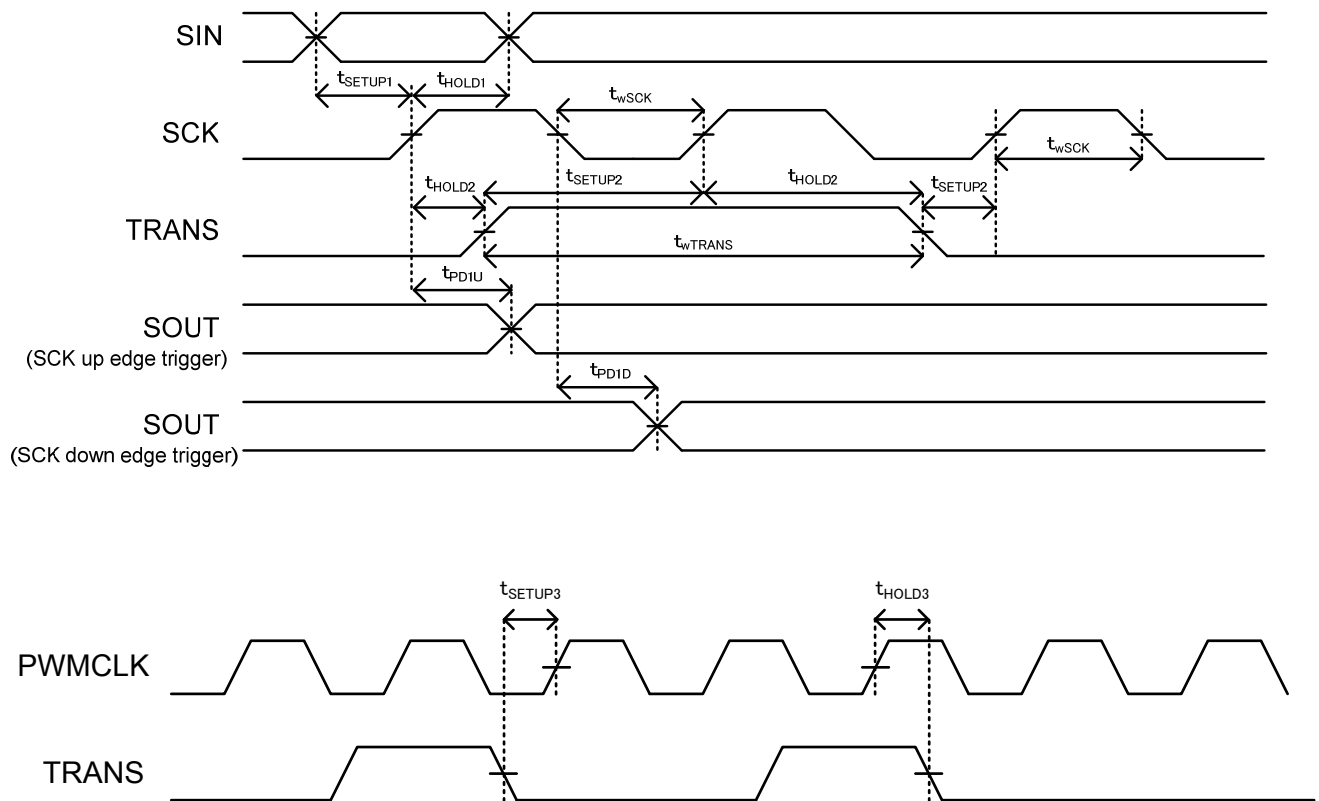

22-2) \overline{OUTn}



22-3) PWMCLK, $\overline{\text{OUT0}}$ to $\overline{\text{OUT15}}$

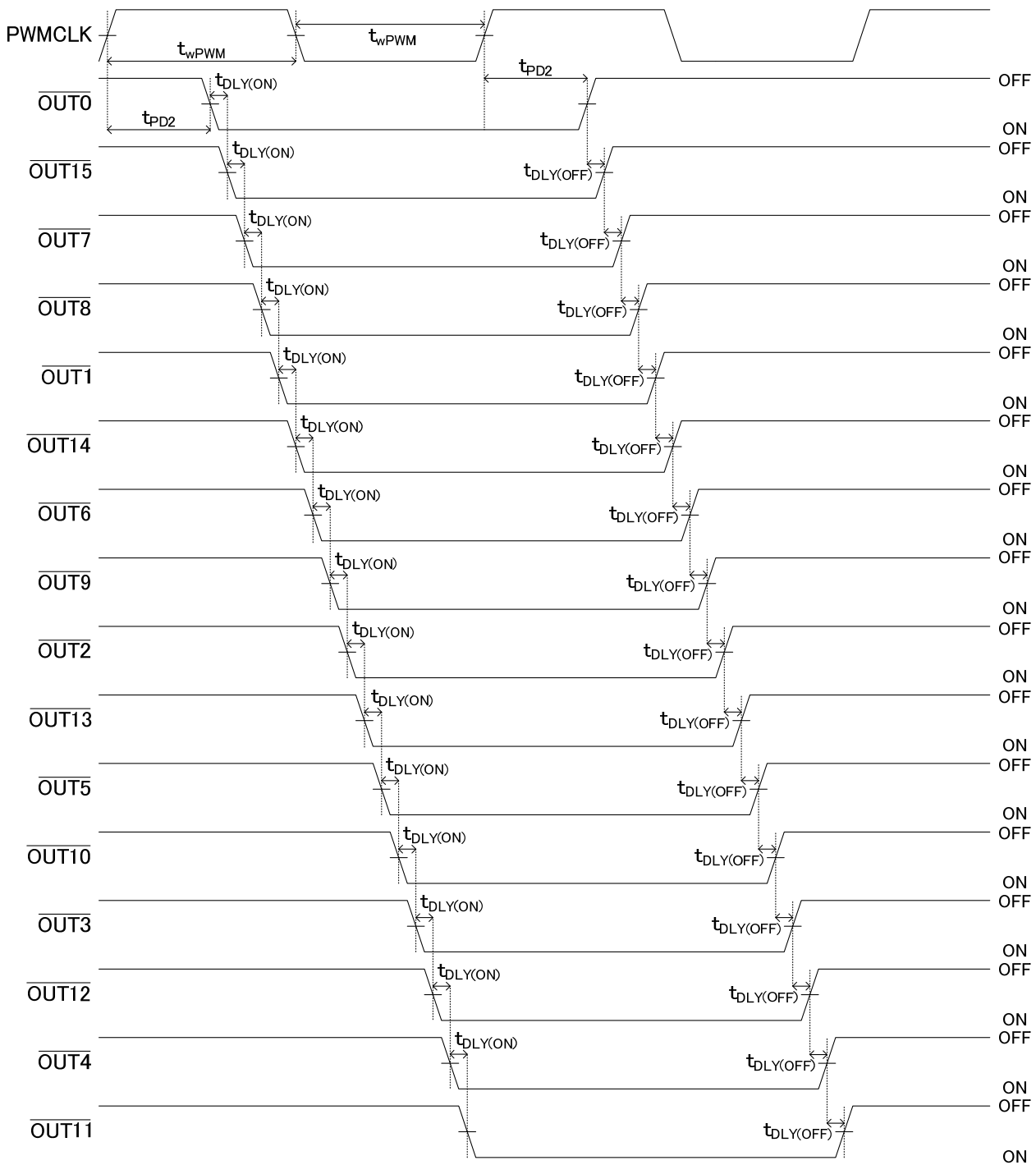

$\overline{\text{OUTn}}$ is a voltage waveform.

23.Reference data

This data is provided for reference only. So, in designing for mass production, take enough care in evaluating IC operation.

Output Current – R_{EXT} (The output gain control data is default.)

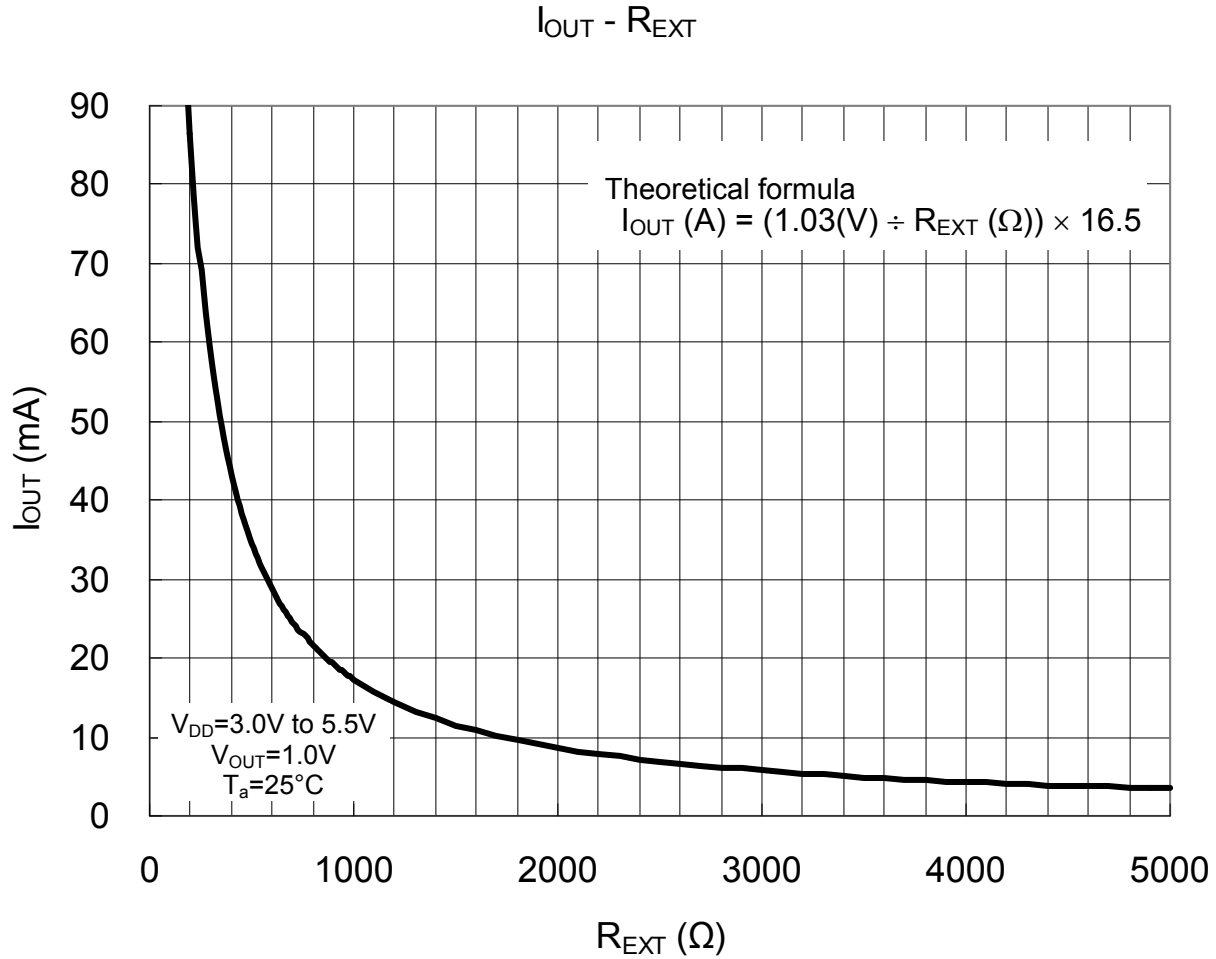

24.Reference data

This data is provided for reference only. So, in designing for mass production, take enough care in evaluating IC operation.

Outputcurrent (I_{OUT}) – Outputvoltage (V_{OUT})

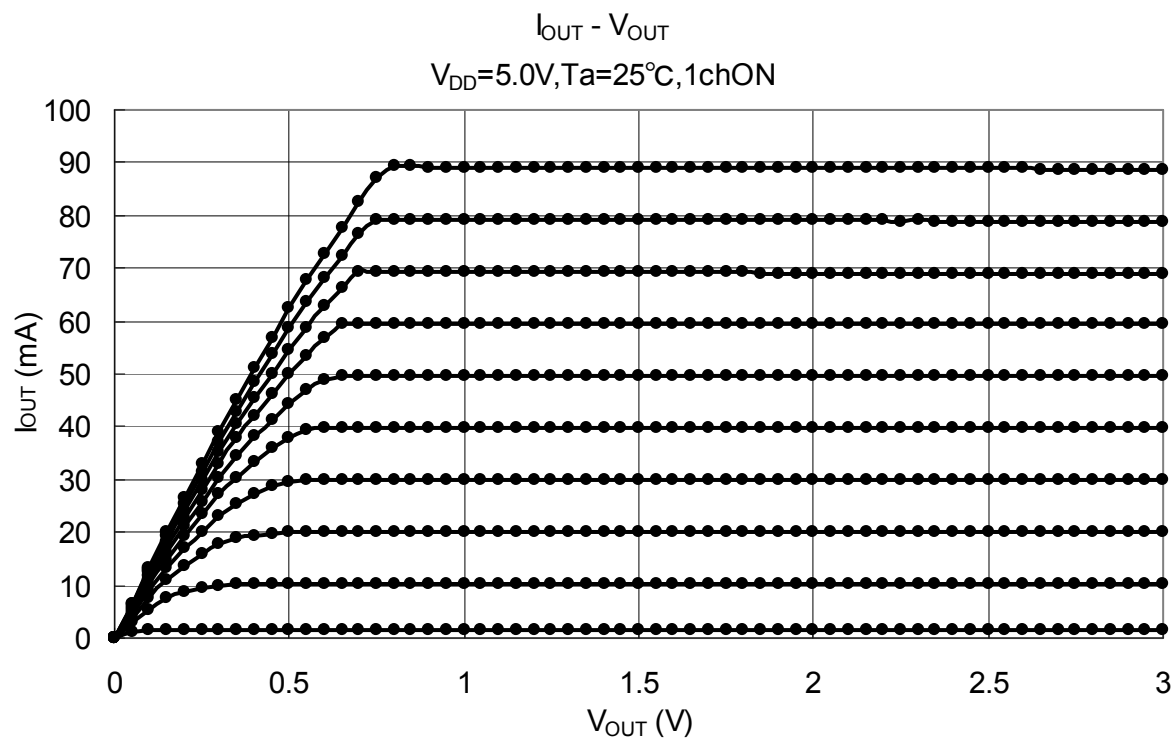
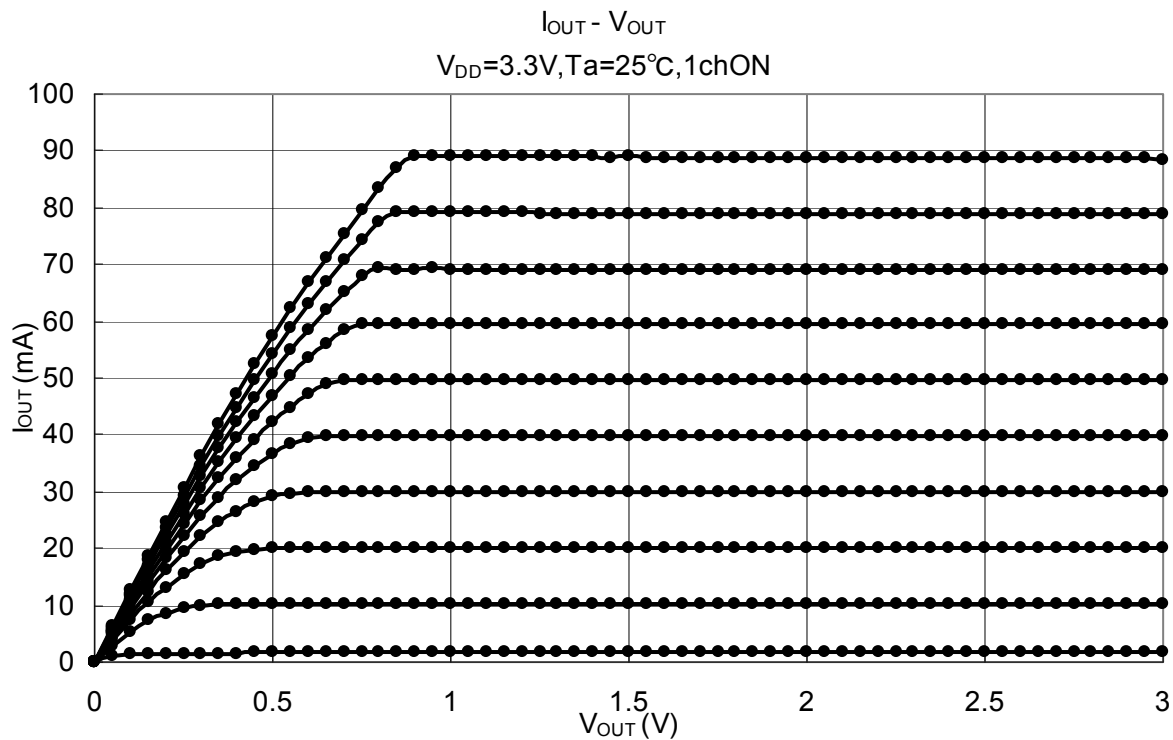

Notes on design of ICs**1. Regarding decoupling capacitor between power supply and GND**

It is recommended that decoupling capacitor between power supply and GND should place as near IC as possible.

2. Regarding resistors for setting of output current

When resistors for setting of output current (R_{EXT}) are used commonly by many ICs, in designing for mass production, take enough care in evaluating IC operation.

3. Regarding PCB layout

There is only one GND terminal on this device when the inductance in the GND line and the resistor are large, the device may malfunction due to the GND noise when output switching by the circuit board pattern and wiring.

Therefore, take care when designing the circuit board pattern layout and the wiring from the controller.

4. Please check the latest technical material at the time of mass production.

Package dimension
HTSSOP24-P-300-0.65

Unit : mm

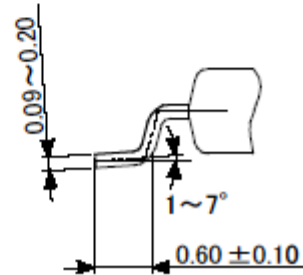
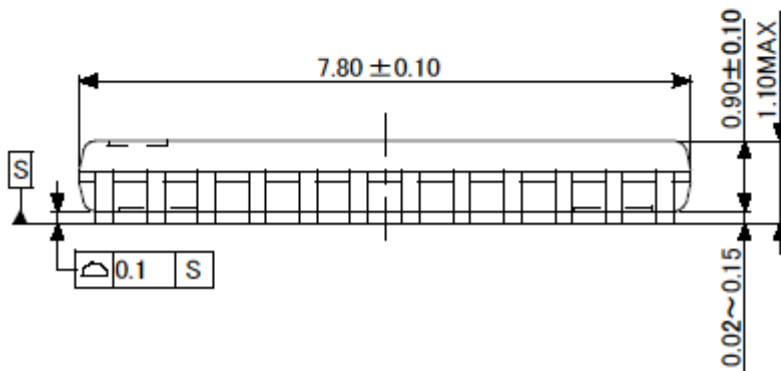
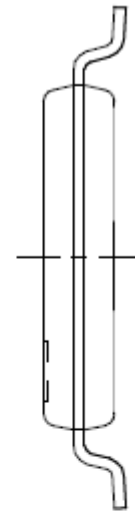
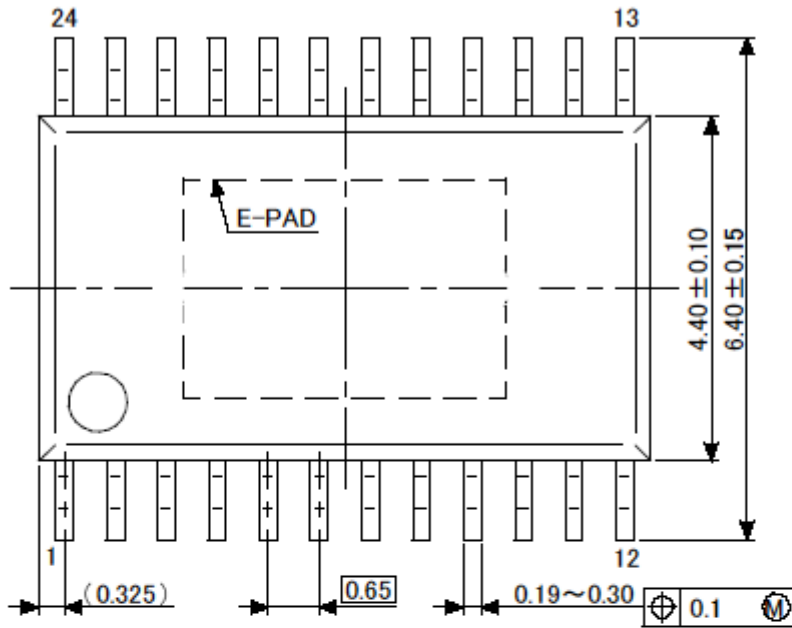

Wight : 0.10 g (Typ.)

Notes on Contents**1. Block Diagrams**

Some of the functional blocks, circuits, or constants in the block diagram may be omitted or simplified for explanatory purposes.

2. Equivalent Circuits

The equivalent circuit diagrams may be simplified or some parts of them may be omitted for explanatory purposes.

3. Timing Charts

Timing charts may be simplified for explanatory purposes.

4. Application Circuits

The application circuits shown in this document are provided for reference purposes only. Thorough evaluation is required, especially at the mass production design stage.

Toshiba does not grant any license to any industrial property rights by providing these examples of application circuits.

5. Test Circuits

Components in the test circuits are used only to obtain and confirm the device characteristics. These components and circuits are not guaranteed to prevent malfunction or failure from occurring in the application equipment.

IC Usage Considerations

Notes on handling of ICs

- [1] The absolute maximum ratings of a semiconductor device are a set of ratings that must not be exceeded, even for a moment. Do not exceed any of these ratings.
Exceeding the rating(s) may cause the device breakdown, damage or deterioration, and may result injury by explosion or combustion.
- [2] Use an appropriate power supply fuse to ensure that a large current does not continuously flow in case of over current and/or IC failure. The IC will fully break down when used under conditions that exceed its absolute maximum ratings, when the wiring is routed improperly or when an abnormal pulse noise occurs from the wiring or load, causing a large current to continuously flow and the breakdown can lead smoke or ignition. To minimize the effects of the flow of a large current in case of breakdown, appropriate settings, such as fuse capacity, fusing time and insertion circuit location, are required.
- [3] If your design includes an inductive load such as a motor coil, incorporate a protection circuit into the design to prevent device malfunction or breakdown caused by the current resulting from the inrush current at power ON or the negative current resulting from the back electromotive force at power OFF. IC breakdown may cause injury, smoke or ignition.
Use a stable power supply with ICs with built-in protection functions. If the power supply is unstable, the protection function may not operate, causing IC breakdown. IC breakdown may cause injury, smoke or ignition.
- [4] Do not insert devices in the wrong orientation or incorrectly.
Make sure that the positive and negative terminals of power supplies are connected properly.
Otherwise, the current or power consumption may exceed the absolute maximum rating, and exceeding the rating(s) may cause the device breakdown, damage or deterioration, and may result injury by explosion or combustion.
In addition, do not use any device that is applied the current with inserting in the wrong orientation or incorrectly even just one time.
- [5] Carefully select external components (such as inputs and negative feedback capacitors) and load components (such as speakers), for example, power amp and regulator.
If there is a large amount of leakage current such as input or negative feedback condenser, the IC output DC voltage will increase. If this output voltage is connected to a speaker with low input withstand voltage, overcurrent or IC failure can cause smoke or ignition. (The over current can cause smoke or ignition from the IC itself.) In particular, please pay attention when using a Bridge Tied Load (BTL) connection type IC that inputs output DC voltage to a speaker directly.

Points to remember on handling of ICs

- (1) Heat Radiation Design
In using an IC with large current flow such as power amp, regulator or driver, please design the device so that heat is appropriately radiated, not to exceed the specified junction temperature (T_J) at any time and condition. These ICs generate heat even during normal use. An inadequate IC heat radiation design can lead to decrease in IC life, deterioration of IC characteristics or IC breakdown. In addition, please design the device taking into consideration the effect of IC heat radiation with peripheral components.
- (2) Back-EMF
When a motor rotates in the reverse direction, stops or slows down abruptly, a current flow back to the motor's power supply due to the effect of back-EMF. If the current sink capability of the power supply is small, the device's motor power supply and output pins might be exposed to conditions beyond absolute maximum ratings. To avoid this problem, take the effect of back-EMF into consideration in system design.
- (3) Thermal Shutdown Circuit
Thermal shutdown circuits do not necessarily protect ICs under all circumstances. If the thermal shutdown circuits operate against the over temperature, clear the heat generation status immediately.
Depending on the method of use and usage conditions, such as exceeding absolute maximum ratings can cause the thermal shutdown circuit to not operate properly or IC breakdown before operation.

RESTRICTIONS ON PRODUCT USE

- Toshiba Corporation, and its subsidiaries and affiliates (collectively "TOSHIBA"), reserve the right to make changes to the information in this document, and related hardware, software and systems (collectively "Product") without notice.
- This document and any information herein may not be reproduced without prior written permission from TOSHIBA. Even with TOSHIBA's written permission, reproduction is permissible only if reproduction is without alteration/omission.
- Though TOSHIBA works continually to improve Product's quality and reliability, Product can malfunction or fail. Customers are responsible for complying with safety standards and for providing adequate designs and safeguards for their hardware, software and systems which minimize risk and avoid situations in which a malfunction or failure of Product could cause loss of human life, bodily injury or damage to property, including data loss or corruption. Before customers use the Product, create designs including the Product, or incorporate the Product into their own applications, customers must also refer to and comply with (a) the latest versions of all relevant TOSHIBA information, including without limitation, this document, the specifications, the data sheets and application notes for Product and the precautions and conditions set forth in the "TOSHIBA Semiconductor Reliability Handbook" and (b) the instructions for the application with which the Product will be used with or for. Customers are solely responsible for all aspects of their own product design or applications, including but not limited to (a) determining the appropriateness of the use of this Product in such design or applications; (b) evaluating and determining the applicability of any information contained in this document, or in charts, diagrams, programs, algorithms, sample application circuits, or any other referenced documents; and (c) validating all operating parameters for such designs and applications. **TOSHIBA ASSUMES NO LIABILITY FOR CUSTOMERS' PRODUCT DESIGN OR APPLICATIONS.**
- Product is intended for use in general electronics applications (e.g., computers, personal equipment, office equipment, measuring equipment, industrial robots and home electronics appliances) or for specific applications as expressly stated in this document. Product is neither intended nor warranted for use in equipment or systems that require extraordinarily high levels of quality and/or reliability and/or a malfunction or failure of which may cause loss of human life, bodily injury, serious property damage or serious public impact ("Unintended Use"). Unintended Use includes, without limitation, equipment used in nuclear facilities, equipment used in the aerospace industry, medical equipment, equipment used for automobiles, trains, ships and other transportation, traffic signaling equipment, equipment used to control combustions or explosions, safety devices, elevators and escalators, devices related to electric power, and equipment used in finance-related fields. Do not use Product for Unintended Use unless specifically permitted in this document.
- Do not disassemble, analyze, reverse-engineer, alter, modify, translate or copy Product, whether in whole or in part.
- Product shall not be used for or incorporated into any products or systems whose manufacture, use, or sale is prohibited under any applicable laws or regulations.
- The information contained herein is presented only as guidance for Product use. No responsibility is assumed by TOSHIBA for any infringement of patents or any other intellectual property rights of third parties that may result from the use of Product. No license to any intellectual property right is granted by this document, whether express or implied, by estoppel or otherwise.
- **ABSENT A WRITTEN SIGNED AGREEMENT, EXCEPT AS PROVIDED IN THE RELEVANT TERMS AND CONDITIONS OF SALE FOR PRODUCT, AND TO THE MAXIMUM EXTENT ALLOWABLE BY LAW, TOSHIBA (1) ASSUMES NO LIABILITY WHATSOEVER, INCLUDING WITHOUT LIMITATION, INDIRECT, CONSEQUENTIAL, SPECIAL, OR INCIDENTAL DAMAGES OR LOSS, INCLUDING WITHOUT LIMITATION, LOSS OF PROFITS, LOSS OF OPPORTUNITIES, BUSINESS INTERRUPTION AND LOSS OF DATA, AND (2) DISCLAIMS ANY AND ALL EXPRESS OR IMPLIED WARRANTIES AND CONDITIONS RELATED TO SALE, USE OF PRODUCT, OR INFORMATION, INCLUDING WARRANTIES OR CONDITIONS OF MERCHANTABILITY, FITNESS FOR A PARTICULAR PURPOSE, ACCURACY OF INFORMATION, OR NONINFRINGEMENT.**
- Do not use or otherwise make available Product or related software or technology for any military purposes, including without limitation, for the design, development, use, stockpiling or manufacturing of nuclear, chemical, or biological weapons or missile technology products (mass destruction weapons). Product and related software and technology may be controlled under the Japanese Foreign Exchange and Foreign Trade Law and the U.S. Export Administration Regulations. Export and re-export of Product or related software or technology are strictly prohibited except in compliance with all applicable export laws and regulations.
- Please contact your TOSHIBA sales representative for details as to environmental matters such as the RoHS compatibility of Product. Please use Product in compliance with all applicable laws and regulations that regulate the inclusion or use of controlled substances, including without limitation, the EU RoHS Directive. TOSHIBA assumes no liability for damages or losses occurring as a result of noncompliance with applicable laws and regulations.