

# TB62777FNG, TB62777FG

## 8-Channel Constant-Current LED Driver of the 3.3-V and 5-V Power Supply Voltage Operation

The TB62777FNG/FG is comprised of constant-current drivers designed for LEDs and LED panel displays.

The regulated current sources are designed to provide a constant current, which is adjustable through one external resistor.

The TB62777FNG/FG incorporates eight channels of shift registers, latches, AND gates and constant-current outputs.

Fabricated using the Bi-CMOS process, the TB62777FNG/FG is capable of high-speed data transfers.

The TB62777FNG/FG is RoHS.

### Features

- Power supply voltages:  $V_{DD} = 3.3\text{ V}/5\text{ V}$
- Output drive capability and output count:  $50\text{ mA} \times 8\text{ channels}$
- Constant-current output range: 5 to 40 mA
- Voltage applied to constant-current output terminals: 0.4 V (min,  $I_{OUT} = 5\text{ to }40\text{ mA}$ )
- Designed for common-anode LEDs
- Thermal shutdown (TSD) (min:  $150^{\circ}\text{C}$ )
- Power on reset (POR)
- Logical input signal voltage level: 3.3-V and 5-V CMOS interfaces (Schmitt trigger input)
- Maximum output voltage: 25V
- Serial data transfer rate: 25 MHz (max) @cascade connection
- Operating temperature range:  $T_{opr} = -40\text{ to }85^{\circ}\text{C}$
- Package: SSOP16-P-225-0.65B/ SSOP16-P-225-1.00A
- Constant-current accuracy

Output Voltage	Current accuracy Between Channels	Current Accuracy Between ICs	Output Current
0.4 V to 4 V	$\pm 3\%$	$\pm 6\%$	15 mA

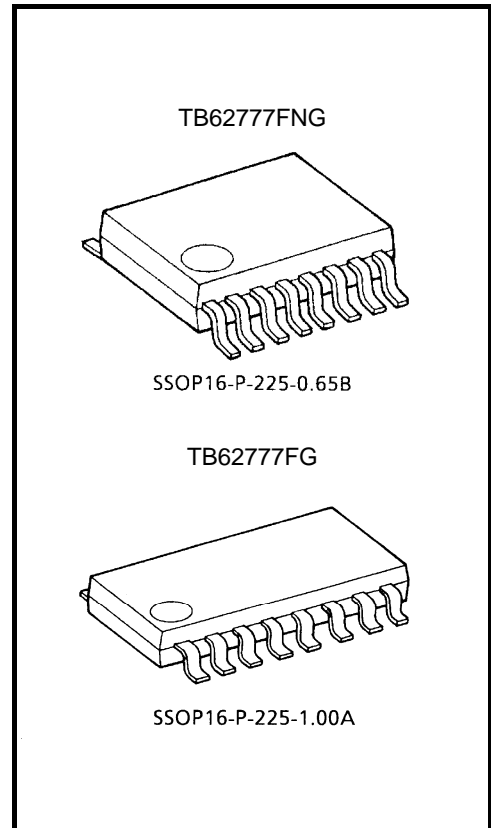

Weight: SSOP16-P-225-0.65B 0.07 g (typ.)  
 SSOP16-P-225-1.00A 0.14 g (typ.)



For part availability and ordering information please call Toll Free: 800.984.5337

Website: [www.marktechopto.com](http://www.marktechopto.com) | Email: [info@marktechopto.com](mailto:info@marktechopto.com)

## Pin Assignment (top view)

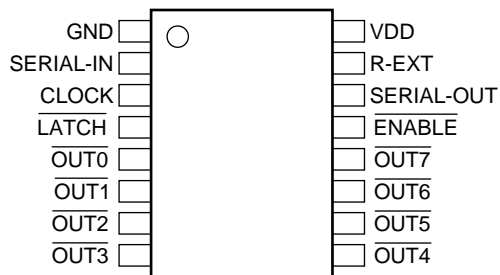

## Block Diagram

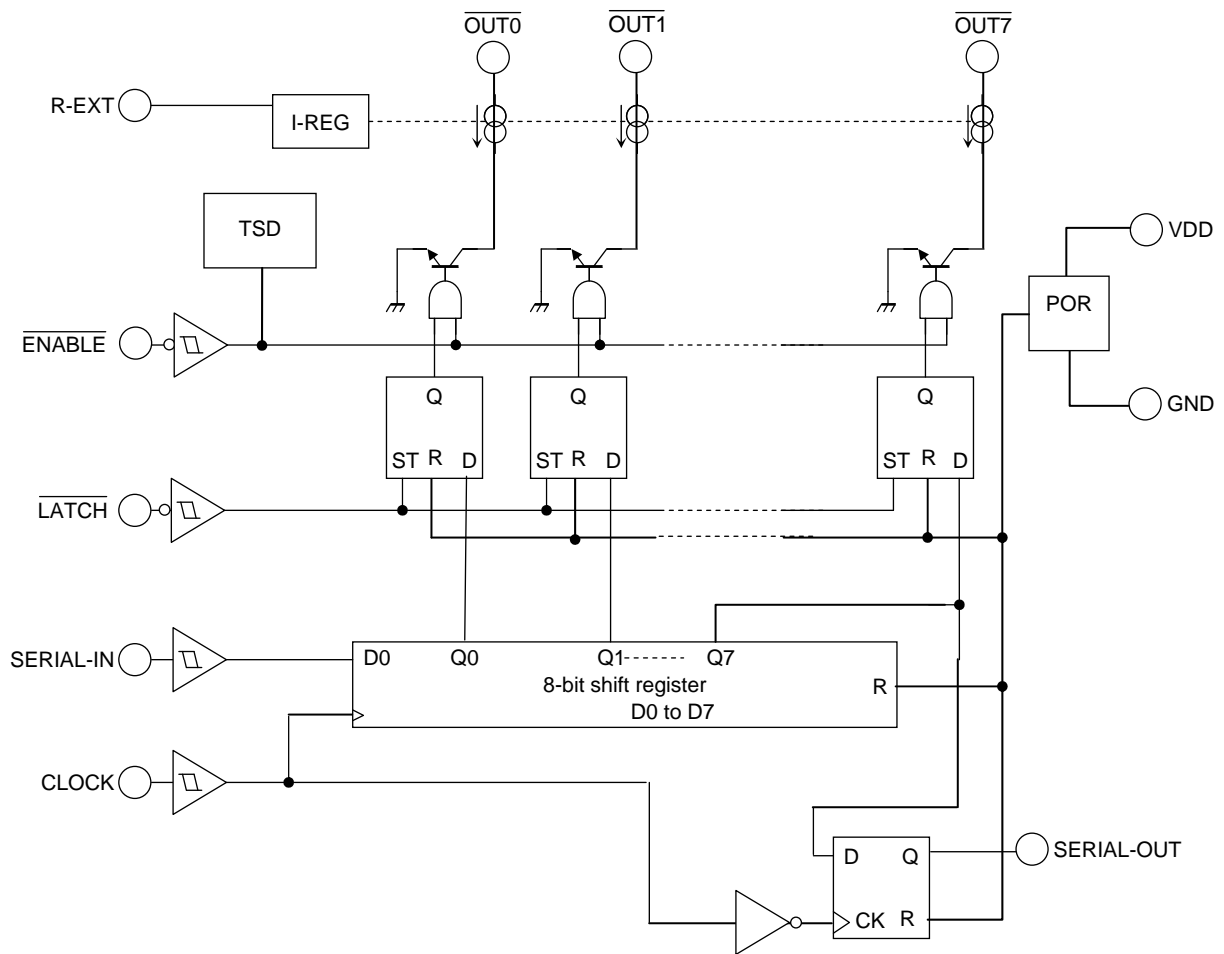

## Truth Table

CLOCK	LATCH	ENABLE	SERIAL-IN	OUT0 ... OUT5 ... OUT7	SERIAL-OUT
↑	H	L	D <sub>n</sub>	D <sub>n</sub> ... D <sub>n-5</sub> ... D <sub>n-7</sub>	No change
↑	L	L	D <sub>n+1</sub>	No Change	No change
↑	H	L	D <sub>n+2</sub>	D <sub>n+2</sub> ... D <sub>n-3</sub> ... D <sub>n-5</sub>	No change
↑	X	H	D <sub>n+3</sub>	OFF	No change
↓	X	H	D <sub>n+3</sub>	OFF	D <sub>n-4</sub>

Note 1:  $\overline{\text{OUT0}}$  to  $\overline{\text{OUT7}}$  = On when D<sub>n</sub> = H;  $\overline{\text{OUT0}}$  to  $\overline{\text{OUT7}}$  = Off when D<sub>n</sub> = L.

**Timing Diagram**

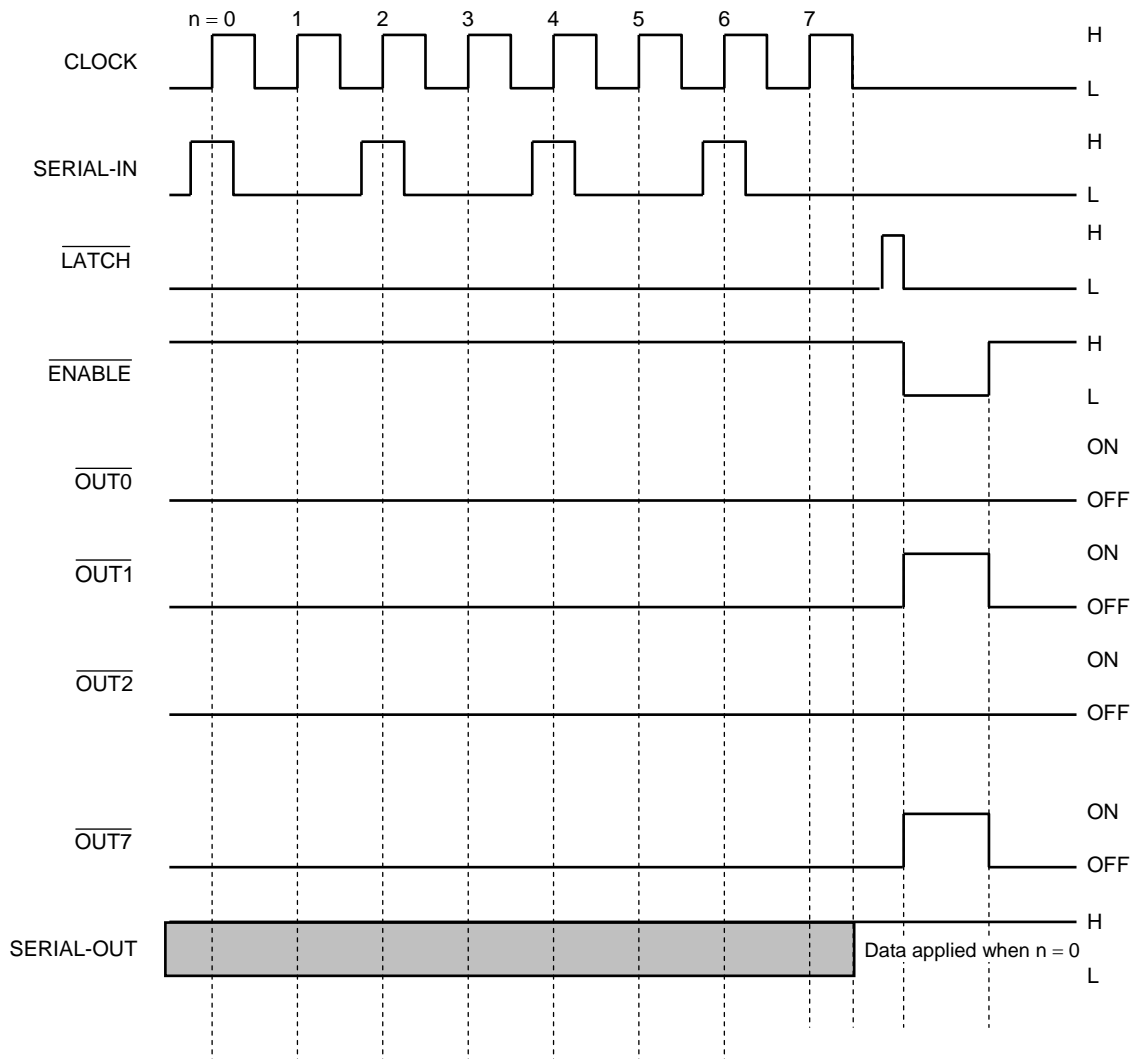

Note 1: Latches are level-sensitive, not edge-triggered.

Note 2: The TB62777FNG can be used at 3.3 V or 5.0 V. However, the  $V_{DD}$  supply voltage must be equal to the input voltage.

Note 3: Serial data is shifted out of SERIAL-OUT on the falling edge of CLOCK.

Marks: The latches hold data while the  $\overline{\text{LATCH}}$  terminal is held Low. When the  $\overline{\text{LATCH}}$  terminal is High, the latches do not hold data and pass it transparently. When the  $\overline{\text{ENABLE}}$  terminal is Low,  $\overline{\text{OUT0}}$  to  $\overline{\text{OUT7}}$  toggle between ON and OFF according to the data. When the  $\overline{\text{ENABLE}}$  terminal is High,  $\overline{\text{OUT0}}$  to  $\overline{\text{OUT7}}$  are forced OFF.

**Terminal Description**

Pin No.	Pin Name	Function
1	GND	GND terminal
2	SERIAL-IN	Serial data input terminal
3	CLOCK	Serial clock input terminal
4	LATCH	Latch input terminal
5	$\overline{\text{OUT0}}$	Constant-current output terminal (Open collector)
6	$\overline{\text{OUT1}}$	Constant-current output terminal (Open collector)
7	$\overline{\text{OUT2}}$	Constant-current output terminal (Open collector)
8	$\overline{\text{OUT3}}$	Constant-current output terminal (Open collector)
9	$\overline{\text{OUT4}}$	Constant-current output terminal (Open collector)
10	$\overline{\text{OUT5}}$	Constant-current output terminal (Open collector)
11	$\overline{\text{OUT6}}$	Constant-current output terminal (Open collector)
12	$\overline{\text{OUT7}}$	Constant-current output terminal (Open collector)
13	$\overline{\text{ENABLE}}$	Output enable input terminal All outputs ( $\overline{\text{OUT0}}$ to $\overline{\text{OUT7}}$ ) are disabled when the $\overline{\text{ENABLE}}$ terminal is driven High, and enabled when it is driven Low.
14	SERIAL-OUT	Serial data output terminal. Serial data is clocked out on the falling edge of CLOCK.
15	R-EXT	An external resistor is connected between this terminal and ground. $\overline{\text{OUT0}}$ to $\overline{\text{OUT7}}$ are adjusted to the same current value.
16	V <sub>DD</sub>	Power supply terminal

**Equivalent Circuits for Inputs and Outputs**

**CLOCK, SERIAL-IN,  $\overline{\text{ENABLE}}$ , LATCH Terminals**

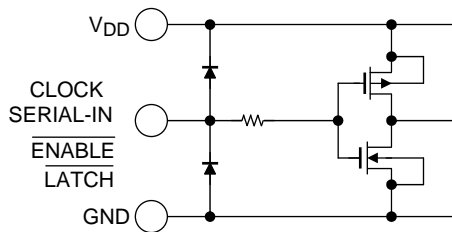

**SERIAL-OUT Terminal**

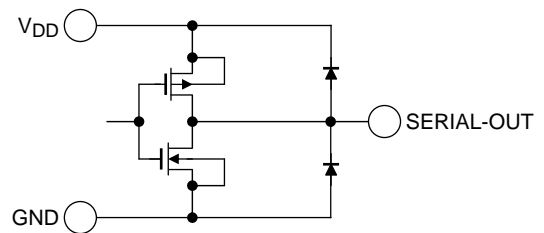

**$\overline{\text{OUT0}}$  to  $\overline{\text{OUT7}}$  Constant-current Output Terminals**

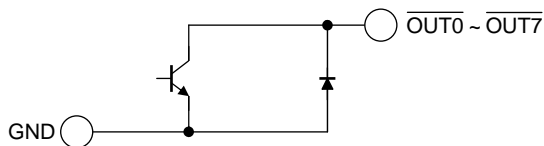

## Absolute Maximum Ratings (Ta = 25°C)

Characteristics	Symbol	Rating	Unit
Supply voltage	V <sub>DD</sub>	6.0	V
Input voltage	V <sub>IN</sub>	-0.3 to V <sub>DD</sub> + 0.3 (Note 1)	V
Output current	I <sub>OUT</sub>	55	mA/ch
Output voltage	V <sub>OUT</sub>	-0.3 to 25	V
Power dissipation	P <sub>d</sub>	1.19(FG TYPE) / 1.02(FNG TYPE) (Notes 2 and 3)	W
Thermal resistance	R <sub>th(j-a)</sub>	105(FG TYPE) / 122(FNG TYPE) (Note 2)	°C/W
Operating temperature range	T <sub>opr</sub>	-40 to 85	°C
Storage temperature range	T <sub>stg</sub>	-55 to 150	°C
Maximum junction temperature	T <sub>j</sub>	150	°C

Note 1: However, do not exceed 6.0 V.

Note 2: When mounted on a PCB (76.2 × 114.3 × 1.6 mm; Cu = 30%; 35-μm-thick; SEMI-compliant)

Note 3: Power dissipation is reduced by 1/R<sub>th(j-a)</sub> for each °C above 25°C ambient.

## Operating Ranges (unless otherwise specified, Ta = -40°C to 85°C)

Characteristics	Symbol	Test Condition	Min	Typ.	Max	Unit
Supply voltage	V <sub>DD</sub>	—	3	—	5.5	V
Output voltage	V <sub>OUT</sub>	$\overline{\text{OUT0}}$ to $\overline{\text{OUT7}}$	0.4	—	4	V
Output current	I <sub>OUT</sub>	$\overline{\text{OUT0}}$ to $\overline{\text{OUT7}}$	5	—	40	mA/ch
	I <sub>OH</sub>	SERIAL-OUT	—	—	-5	mA
	I <sub>OL</sub>	SERIAL-OUT	—	—	5	
Input voltage	V <sub>IH</sub>	SERIAL-IN/CLOCK/ LATCH / ENABLE	0.7 × V <sub>DD</sub>	—	V <sub>DD</sub>	V
	V <sub>IL</sub>		GND	—	0.3 × V <sub>DD</sub>	
Clock frequency	f <sub>CLK</sub>	Cascade connection	—	—	25	MHz
$\overline{\text{LATCH}}$ pulse width	t <sub>wLAT</sub>	(Note 2)	20	—	—	ns
CLOCK pulse width	t <sub>wCLK</sub>	(Note 2)	20	—	—	
$\overline{\text{ENABLE}}$ pulse width	t <sub>wENA</sub>	I <sub>OUT</sub> ≥ 20 mA (Note 2)	2	—	—	μs
		5 mA ≤ I <sub>OUT</sub> ≤ 20 mA (Note 2)	3	—	—	
Setup time	t <sub>SETUP1</sub>	(Note 2)	5	—	—	ns
	t <sub>SETUP2</sub>		5	—	—	
Hold time	t <sub>HOLD1</sub>		5	—	—	
	t <sub>HOLD2</sub>		5	—	—	
Maximum clock rise time	t <sub>r</sub>	Single operation (Notes 1 and 2)	—	—	5	μs
Maximum clock fall time	t <sub>f</sub>		—	—	5	

Note 1: For cascade operation, the CLOCK waveform might become ambiguous, causing the t<sub>r</sub> and t<sub>f</sub> values to be large. Then it may not be possible to meet the timing requirement for data transfer. Please consider the timing carefully.

Note 2: Please see the timing waveform on page 9.

## Electrical Characteristics (Unless otherwise specified, $T_a = 25^\circ\text{C}$ , $V_{DD} = 4.5$ to $5.5$ V)

Characteristics	Symbol	Test Circuit	Test Condition	Min	Typ.	Max	Unit
Output current	$I_{OUT1}$	5	$V_{OUT} = 0.4$ V, R-EXT = 1.2 k $\Omega$ $V_{DD} = 5$ V,	—	15	—	mA
Output current error between ICs	$\Delta I_{OUT1}$	5	$V_{OUT} = 0.4$ V, R-EXT = 1.2 k $\Omega$ All channels ON $V_{DD} = 5$ V,	—	$\pm 3$	$\pm 6$	%
Output current error between channels	$\Delta I_{OUT2}$	5	$V_{OUT} = 0.4$ V, R-EXT = 1.2 k $\Omega$ All channels ON $V_{DD} = 5$ V	—	$\pm 1$	$\pm 3$	%
Output leakage current	$I_{OZ}$	5	$V_{OUT} = 25$ V	—	—	1	$\mu\text{A}$
Input voltage	$V_{IH}$	—	SERIAL-IN/CLOCK/LATCH / ENABLE	$0.7 \times V_{DD}$	—	$V_{DD}$	V
	$V_{IL}$	—	SERIAL-IN/CLOCK/LATCH / ENABLE	GND	—	$0.3 \times V_{DD}$	
Input current	$I_{IH}$	2	$V_{IN} = V_{DD}$ CLOCK/SERIAL-IN /LATCH / ENABLE	—	—	1	$\mu\text{A}$
	$I_{IL}$	3	$V_{IN} = \text{GND}$ CLOCK/SERIAL-IN/LATCH / ENABLE	—	—	-1	
SERIAL-OUT output voltage	$V_{OL}$	1	$I_{OL} = 5.0$ mA, $V_{DD} = 5$ V	—	—	0.3	V
	$V_{OH}$	1	$I_{OH} = -5.0$ mA, $V_{DD} = 5$ V	4.7	—	—	
Changes in constant output current dependent on $V_{DD}$	%/ $V_{DD}$	5	$V_{DD} = 3$ V to $5.5$ V	—	1	2	%
Supply current	$I_{DD}(\text{OFF}) 1$	4	R-EXT = OPEN, $V_{OUT} = 25.0$ V	—	—	1	mA
	$I_{DD}(\text{OFF}) 2$	4	R-EXT = 1.2 k $\Omega$ , $V_{OUT} = 25.0$ V, All channels OFF	—	—	5	
	$I_{DD}(\text{ON})$	4	R-EXT = 1.2 k $\Omega$ , $V_{OUT} = 0.4$ V, All channels ON	—	—	9	

## Switching Characteristics (Unless otherwise specified, $T_a = 25^\circ\text{C}$ , $V_{DD} = 4.5$ to $5.5$ V)

Characteristics	Symbol	Test Circuit	Test Condition (Note 1)	Min	Typ.	Max	Unit
Propagation delay time	$t_{pLH1}$	6	CLK- $\overline{\text{OUT}}_n$ , LATCH = "H", ENABLE = "L"	—	20	300	ns
	$t_{pLH2}$	6	LATCH - $\overline{\text{OUT}}_n$ , ENABLE = "L"	—	20	300	
	$t_{pLH3}$	6	ENABLE - $\overline{\text{OUT}}_n$ , LATCH = "H"	—	20	300	
	$t_{pLH}$	6	CLK-SERIAL OUT	2	10	14	
	$t_{pHL1}$	6	CLK- $\overline{\text{OUT}}_n$ , LATCH = "H", ENABLE = "L"	—	30	340	
	$t_{pHL2}$	6	LATCH - $\overline{\text{OUT}}_n$ , ENABLE = "L"	—	70	340	
	$t_{pHL3}$	6	ENABLE - $\overline{\text{OUT}}_n$ , LATCH = "H"	—	70	340	
	$t_{pHL}$	6	CLK-SERIAL OUT	2	10	14	
Output rise time	$t_{or}$	6	10% to 90% points of $\overline{\text{OUT}}_0$ to $\overline{\text{OUT}}_7$ voltage waveforms	—	20	150	
Output fall time	$t_{of}$	6	90% to 10% points of $\overline{\text{OUT}}_0$ to $\overline{\text{OUT}}_7$ voltage waveforms	—	125.	300	

Note 1:  $T_{opr} = 25^\circ\text{C}$ ,  $V_{DD} = V_{IH} = 5$  V,  $V_{IL} = 0$  V,  $R_{EXT} = 1.2$  k $\Omega$ ,  $I_{OUT} = 15$  mA,  $V_L = 5.0$  V,  
 $C_L = 10.5$  pF (see test circuit 6.)

## Electrical Characteristics (Unless otherwise specified, Ta = 25°C, V<sub>DD</sub> = 3 to 3.6 V)

Characteristics	Symbol	Test Circuit	Test Condition	Min	Typ.	Max	Unit
Output current	I <sub>OUT1</sub>	5	V <sub>OUT</sub> = 0.4 V, R-EXT = 1.2 kΩ V <sub>DD</sub> = 3.3 V	—	15	—	mA
Output current error between ICs	ΔI <sub>OUT1</sub>	5	V <sub>OUT</sub> = 0.4 V, R-EXT = 1.2 kΩ All channels ON V <sub>DD</sub> = 3.3 V	—	±3	±6	%
Output current error between channels	ΔI <sub>OUT2</sub>	5	V <sub>OUT</sub> = 0.4 V, R-EXT = 1.2 kΩ All channels ON V <sub>DD</sub> = 3.3 V	—	±1	±3	%
Output leakage current	I <sub>OZ</sub>	5	V <sub>OUT</sub> = 25 V	—	—	1	μA
Input voltage	V <sub>IH</sub>	—	SERIAL-IN/CLOCK/LATCH / ENABLE	0.7 × V <sub>DD</sub>	—	V <sub>DD</sub>	V
	V <sub>IL</sub>	—	SERIAL-IN/CLOCK/LATCH / ENABLE	GND	—	0.3 × V <sub>DD</sub>	
Input current	I <sub>IH</sub>	2	V <sub>IN</sub> = V <sub>DD</sub> CLOCK/SERIAL-IN/LATCH / ENABLE	—	—	1	μA
	I <sub>IL</sub>	3	V <sub>IN</sub> = GND CLOCK/SERIAL-IN/LATCH / ENABLE	—	—	-1	
SERIAL-OUT output voltage	V <sub>OL</sub>	1	I <sub>OL</sub> = 5.0 mA, V <sub>DD</sub> = 3.3 V	—	—	0.3	V
	V <sub>OH</sub>	1	I <sub>OH</sub> = -5.0 mA, V <sub>DD</sub> = 3.3 V	3.0	—	—	
Changes in constant output current dependent on V <sub>DD</sub>	%/V <sub>DD</sub>	5	V <sub>DD</sub> = 3 V to 5.5 V	—	1	2	%
Supply current	I <sub>DD</sub> (OFF) 1	4	R-EXT = OPEN, V <sub>OUT</sub> = 25.0 V	—	—	1	mA
	I <sub>DD</sub> (OFF) 2	4	R-EXT = 1.2 kΩ, V <sub>OUT</sub> = 25.0 V, All channels OFF	—	—	5	
	I <sub>DD</sub> (ON)	4	R-EXT = 1.2 kΩ, V <sub>OUT</sub> = 0.4 V, All channels ON	—	—	9	

## Switching Characteristics (Unless otherwise specified, Ta = 25°C, V<sub>DD</sub> = 3 to 3.6 V)

Characteristics	Symbol	Test Circuit	Test Condition (Note 1)	Min	Typ.	Max	Unit
Propagation delay time	t <sub>pLH1</sub>	6	CLK-OUT <sub>n</sub> , LATCH = "H", ENABLE = "L"	—	—	300	ns
	t <sub>pLH2</sub>	6	LATCH - OUT <sub>n</sub> , ENABLE = "L"	—	—	300	
	t <sub>pLH3</sub>	6	ENABLE - OUT <sub>n</sub> , LATCH = "H"	—	—	300	
	t <sub>pLH</sub>	6	CLK-SERIAL OUT	2	—	14	
	t <sub>pHL1</sub>	6	CLK-OUT <sub>n</sub> , LATCH = "H", ENABLE = "L"	—	—	340	
	t <sub>pHL2</sub>	6	LATCH - OUT <sub>n</sub> , ENABLE = "L"	—	—	340	
	t <sub>pHL3</sub>	6	ENABLE - OUT <sub>n</sub> , LATCH = "H"	—	—	340	
	t <sub>pHL</sub>	6	CLK-SERIAL OUT	2	—	14	
Output rise time	t <sub>or</sub>	6	10% to 90% points of OUT <sub>0</sub> to OUT <sub>7</sub> voltage waveforms	—	—	150	
Output fall time	t <sub>of</sub>	6	90% to 10% points of OUT <sub>0</sub> to OUT <sub>7</sub> voltage waveforms	—	—	300	

Note 1: T<sub>opr</sub> = 25°C, V<sub>DD</sub> = V<sub>IH</sub> = 3.3 V, V<sub>IL</sub> = 0 V, R<sub>EXT</sub> = 1.2 kΩ, I<sub>OUT</sub> = 15 mA, V<sub>L</sub> = 5.0 V,  
C<sub>L</sub> = 10.5 pF (see test circuit 6.)

**Test Circuits**

**Test Circuit 1: SERIAL-OUT output voltage ( $V_{OH}/V_{OL}$ )**

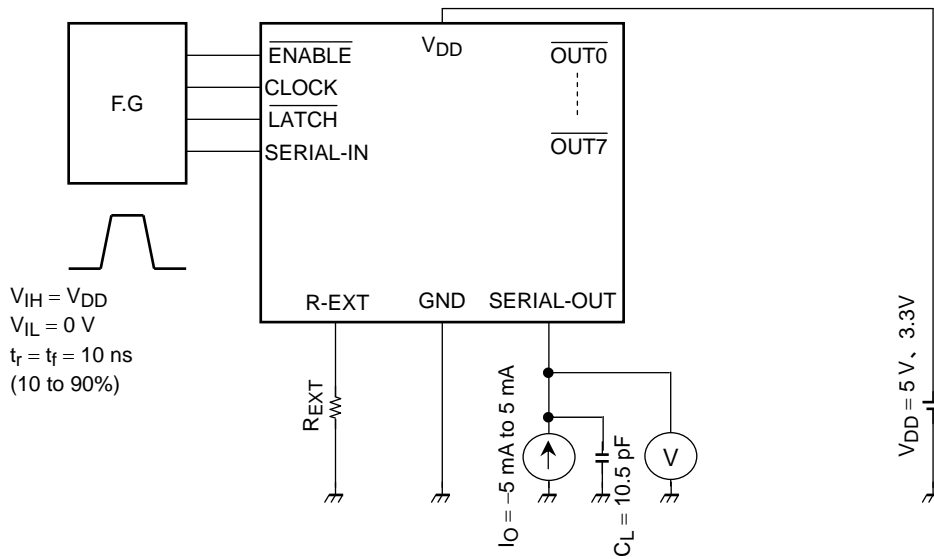

**Test Circuit 2: Input Current ( $I_{IH}$ )**

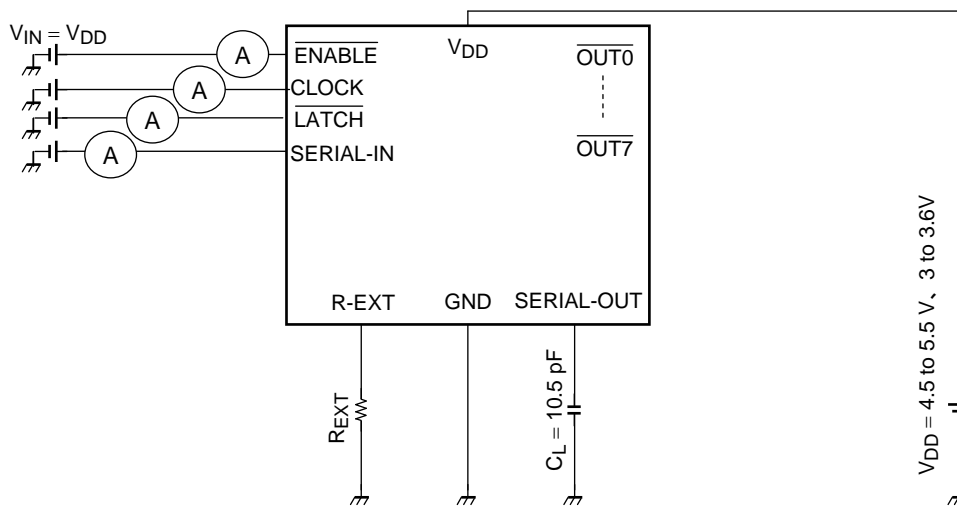

**Test Circuit 3: Input Current ( $I_{IL}$ )**

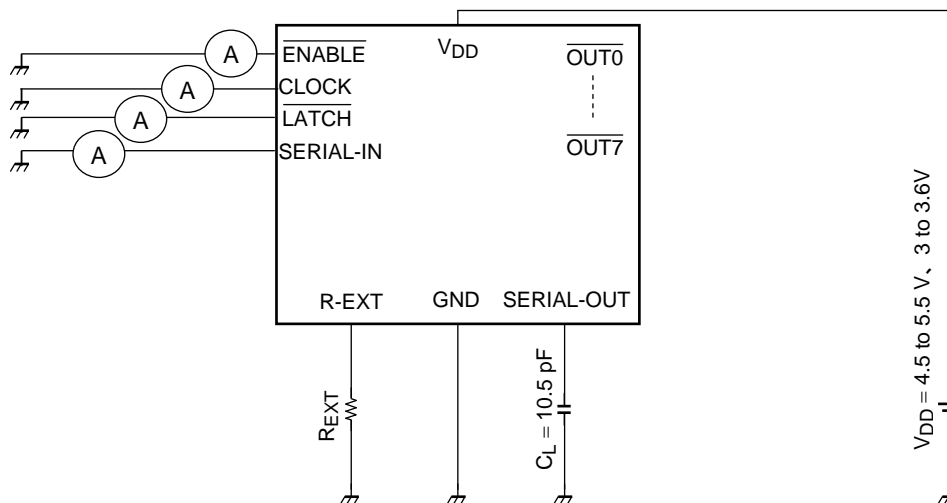

**Test Circuit 4: Supply Current**

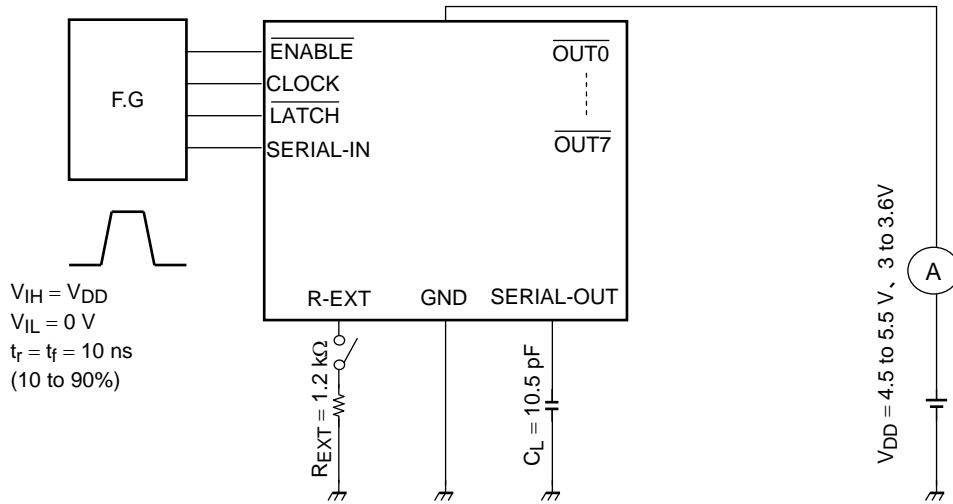

Note: The output terminal is based on the power supply current conditions on page 6 and 7.

**Test Circuit 5: Output Current ( $I_{OUT1}$ ), Output Leakage Current ( $I_{OZ}$ ), Output Current Error Margin ( $\Delta I_{OUT1}/\Delta I_{OUT2}$ ), Current Variation with  $V_{DD}$  ( $\%/V_{DD}$ )**

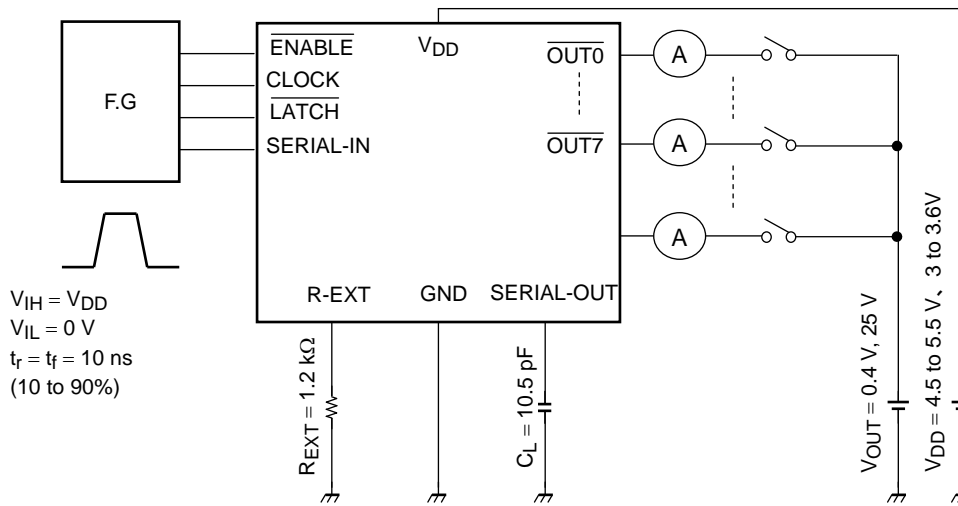

Theoretical output current =  $1.13\text{ V}/R_{EXT} \times 16$

**Test Circuit 6: Switching Characteristics**

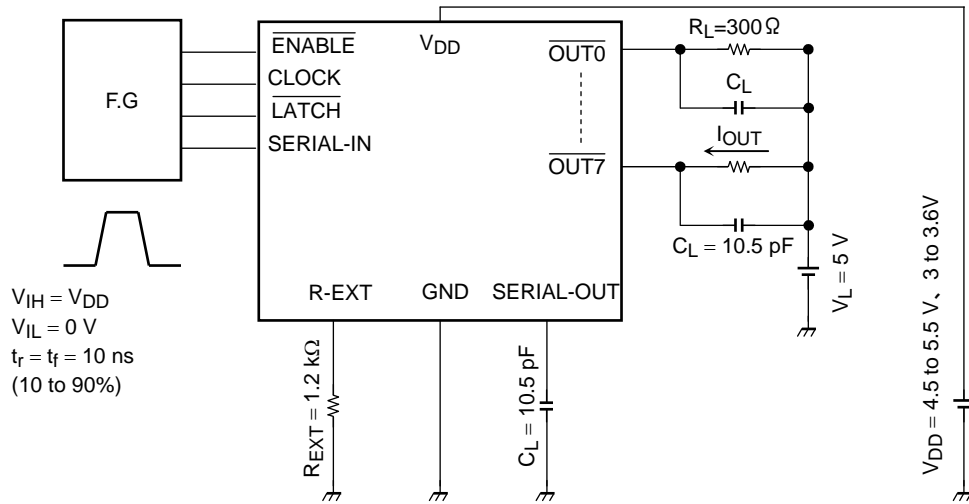

**Timing Waveforms**

**1. CLOCK, SERIAL-IN, SERIAL-OUT**

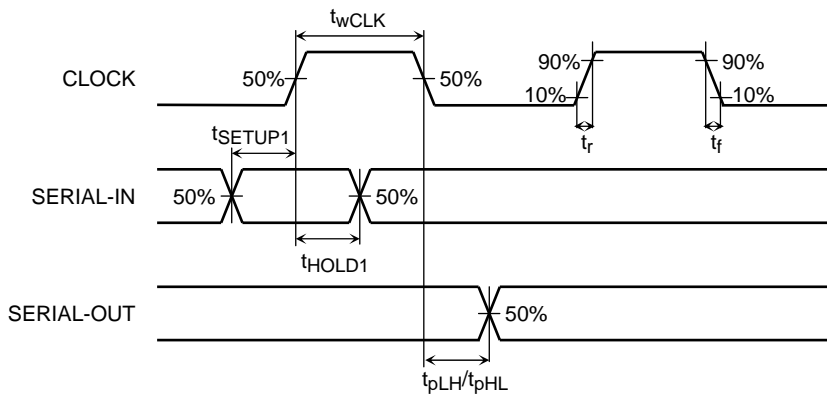

**2. CLOCK, SERIAL-IN, LATCH, ENABLE, OUTn**

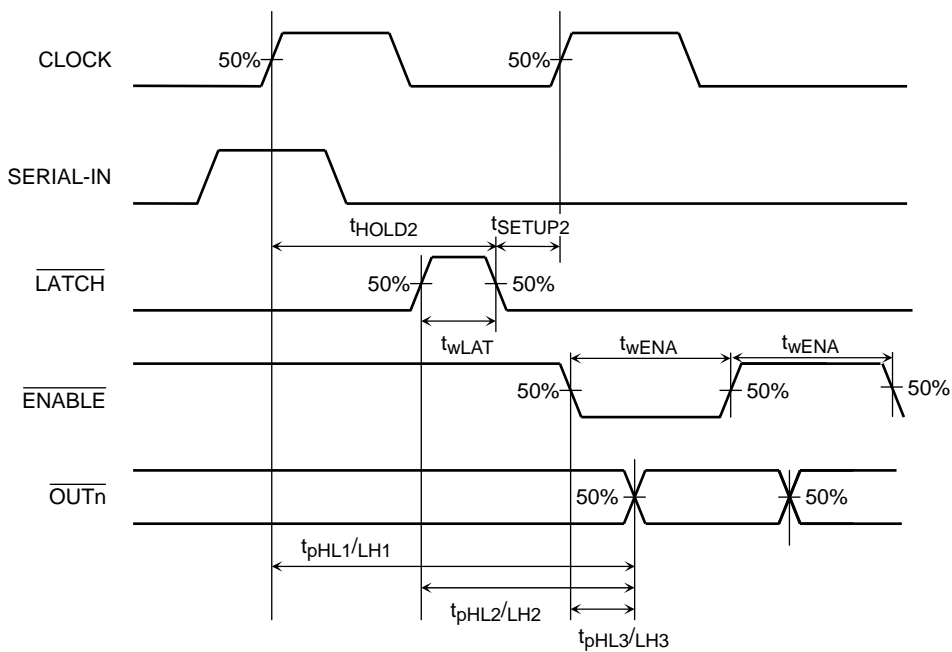

**3. OUTn**

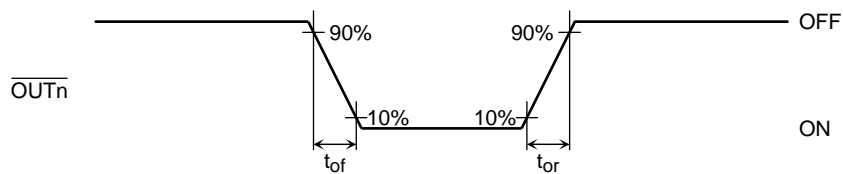

Note: Timing chart waveforms are presented to describe functions and operations and may be simplified. Adequate consideration should be given to timing conditions.

**Output Current vs. Derating (lighting rate) Graph**

PCB Conditions: 76.2 × 114.3 × 1.6 mm, Cu = 30%, 35-μm Thick, SEMI-Compliant  
TB62777FNG

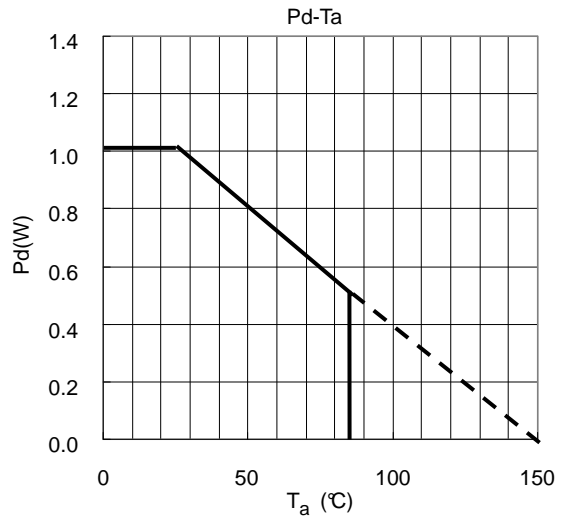
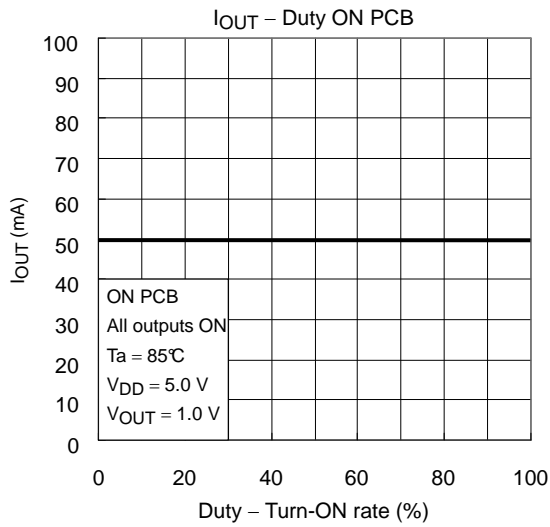

**Output Current vs. External Resistor (typ.)**

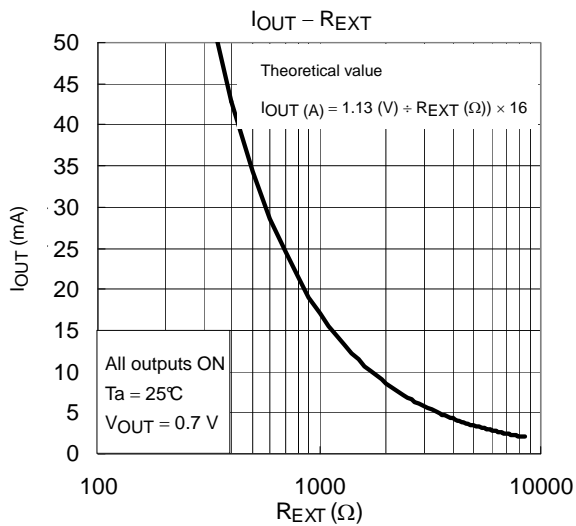

The above graphs are presented merely as a guide and do not constitute any guarantee as to the performance or characteristics of the device. Each product design should be fully evaluated in a real-world environment.

**Application Circuit 1: General Composition for Static Lighting of LEDs**

In the following diagram, it is recommended that the LED supply voltage ( $V_{LED}$ ) be equal to or greater than the sum of  $V_f$  (max) of all LEDs plus 0.7 V.

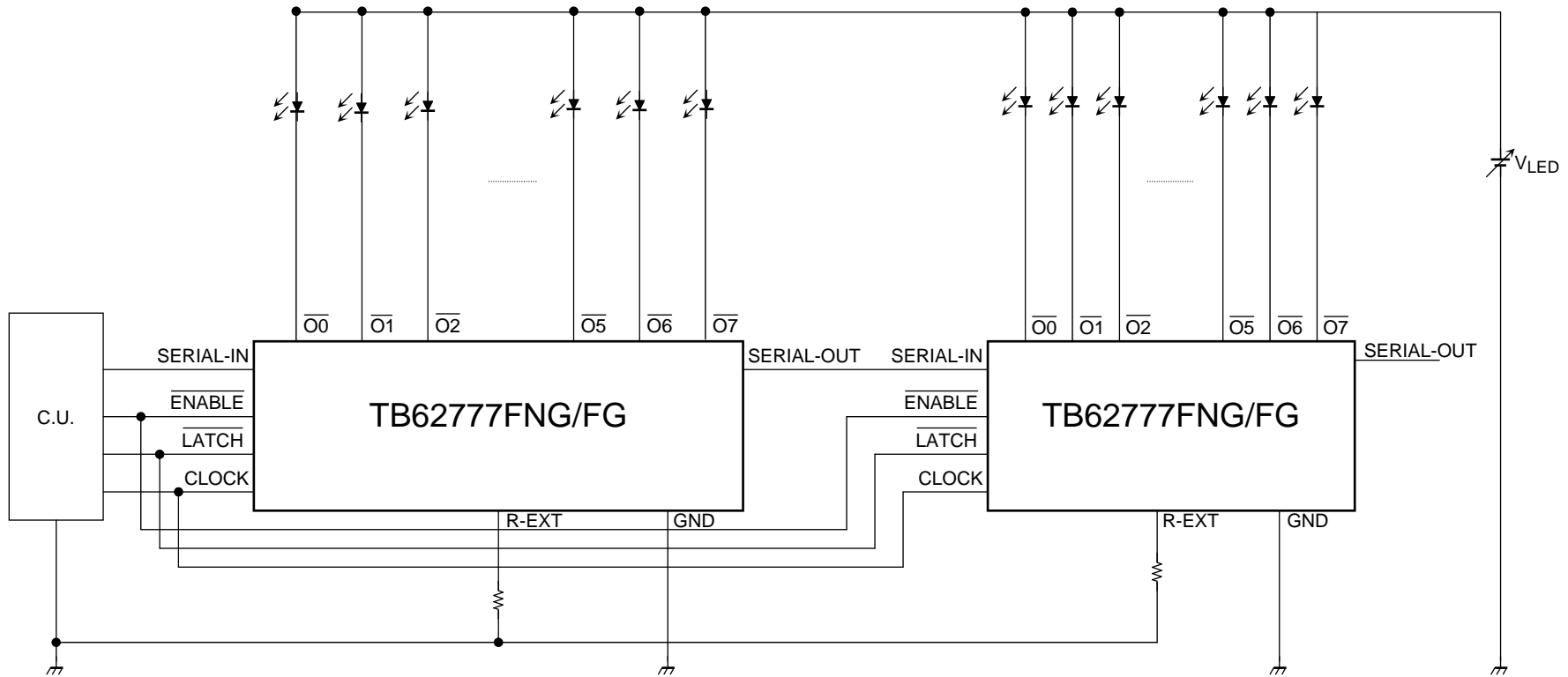

## Application Circuit 2: General Composition for Dynamic Lighting of LEDs

In the following diagram, it is recommended that the LED supply voltage ( $V_{LED}$ ) be equal to or greater than the sum of  $V_f$  (max) of all LEDs plus 0.7 V.

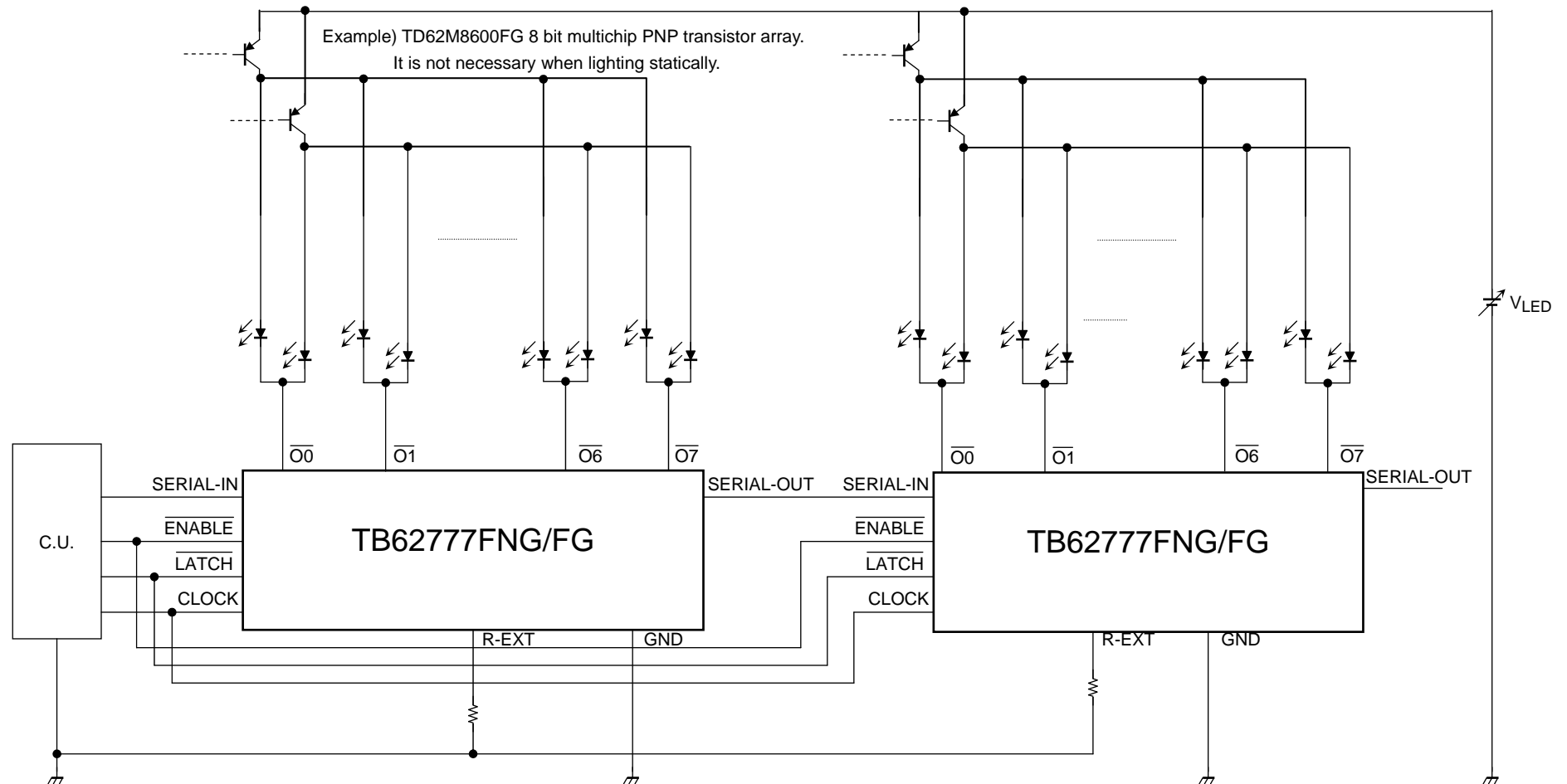

**Package Dimensions**

SSOP16-P-225-0.65B

Unit : mm

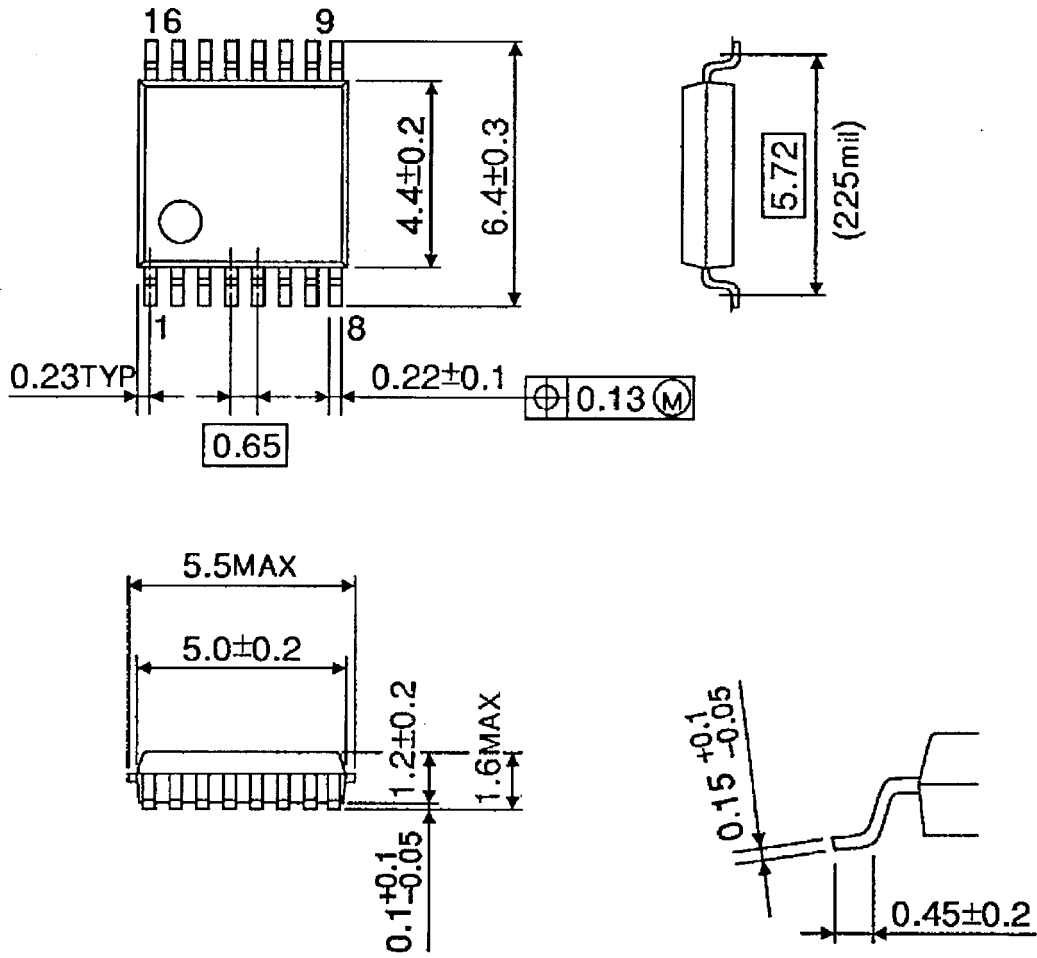

Weight: 0.07 g (typ.)

**Package Dimensions**

SSOP16-P-225-1.00A

Unit : mm

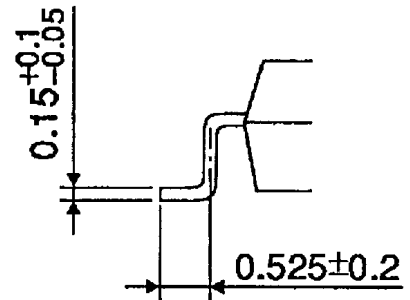
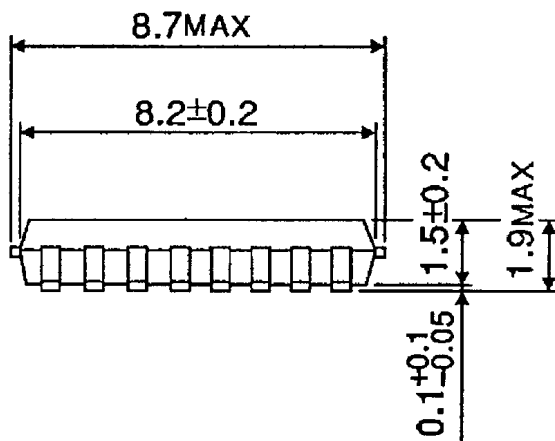
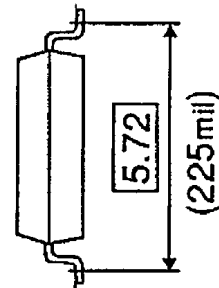
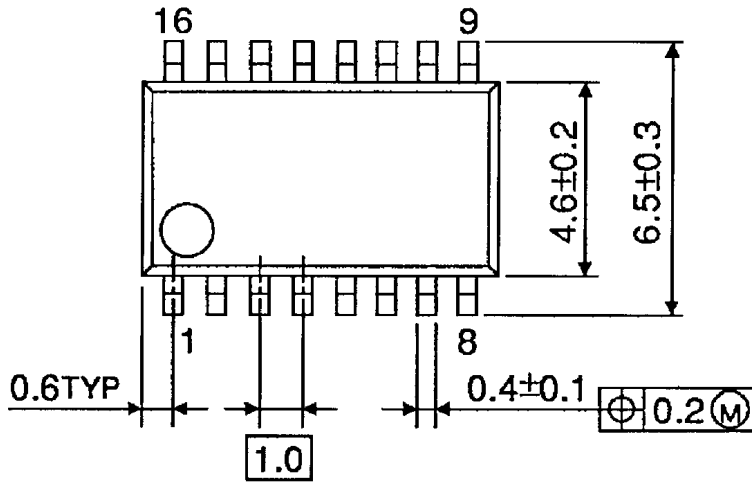

Weight: 0.14 g (typ.)

## Notes on Contents

### 1. Block Diagrams

Some of the functional blocks, circuits, or constants in the block diagram may be omitted or simplified for explanatory purposes.

### 2. Equivalent Circuits

The equivalent circuit diagrams may be simplified or some parts of them may be omitted for explanatory purposes.

### 3. Timing Charts

Timing charts may be simplified for explanatory purposes.

### 4. Application Circuits

The application circuits shown in this document are provided for reference purposes only. Thorough evaluation is required, especially at the mass production design stage.

Toshiba does not grant any license to any industrial property rights by providing these examples of application circuits.

### 5. Test Circuits

Components in the test circuits are used only to obtain and confirm the device characteristics. These components and circuits are not guaranteed to prevent malfunction or failure from occurring in the application equipment.

## IC Usage Considerations

### Notes on handling of ICs

- (1) The absolute maximum ratings of a semiconductor device are a set of ratings that must not be exceeded, even for a moment. Do not exceed any of these ratings.  
Exceeding the rating(s) may cause breakdown, damage or deterioration of the device, and may result in injury by explosion or combustion.
- (2) Use an appropriate power supply fuse to ensure that a large current does not continuously flow in the event of over current and/or IC failure. The IC will fully break down when used under conditions that exceed its absolute maximum ratings, when the wiring is routed improperly or when an abnormal pulse noise occurs from the wiring or load, causing a large current to continuously flow. Such a breakdown can lead to smoke or ignition. To minimize the effects of a large current flow in the event of breakdown, fuse capacity, fusing time, insertion circuit location, and other such suitable settings are required.
- (3) If your design includes an inductive load such as a motor coil, incorporate a protection circuit into the design to prevent device malfunction or breakdown caused by the current resulting from the inrush current at power ON or the negative current resulting from the back electromotive force at power OFF. IC breakdown may cause injury, smoke or ignition.  
For ICs with built-in protection functions, use a stable power supply with. An unstable power supply may cause the protection function to not operate, causing IC breakdown. IC breakdown may cause injury, smoke or ignition.
- (4) Do not insert devices incorrectly or in the wrong orientation. Make sure that the positive and negative terminals of power supplies are connected properly. Otherwise, the current or power consumption may exceed the absolute maximum rating, and exceeding the rating(s) may cause breakdown, damage or deterioration of the device, which may result in injury by explosion or combustion. In addition, do not use any device that has had current applied to it while inserted incorrectly or in the wrong orientation even once.

- (5) Carefully select power amp, regulator, or other external components (such as inputs and negative feedback capacitors) and load components (such as speakers).  
If there is a large amount of leakage current such as input or negative feedback capacitors, the IC output DC voltage will increase. If this output voltage is connected to a speaker with low input withstand voltage, overcurrent or IC failure can cause smoke or ignition. (The over current can cause smoke or ignition from the IC itself.) In particular, please pay attention when using a Bridge Tied Load (BTL) connection type IC that inputs output DC voltage to a speaker directly.

**Points to remember on handling of ICs**

- (1) Heat Dissipation Design  
In using an IC with large current flow such as a power amp, regulator or driver, please design the device so that heat is appropriately dissipated, not to exceed the specified junction temperature ( $T_j$ ) at any time or under any condition. These ICs generate heat even during normal use. An inadequate IC heat dissipation design can lead to decrease in IC life, deterioration of IC characteristics or IC breakdown. In addition, please design the device taking into consideration the effect of IC heat dissipation on peripheral components..
- (2) Back-EMF  
When a motor rotates in the reverse direction, stops, or slows down abruptly, a current flow back to the motor's power supply due to the effect of back-EMF. If the current sink capability of the power supply is small, the device's motor power supply and output pins might be exposed to conditions beyond maximum ratings. To avoid this problem, take the effect of back-EMF into consideration in your system design.

About solderability, following conditions were confirmed

- Solderability

- (1) Use of Sn-37Pb solder Bath

- solder bath temperature = 230°C
    - dipping time = 5 seconds
    - the number of times = once
    - use of R-type flux

- (2) Use of Sn-3.0Ag-0.5Cu solder Bath

- solder bath temperature = 245°C
    - dipping time = 5 seconds
    - the number of times = once
    - use of R-type flux

## RESTRICTIONS ON PRODUCT USE

- Toshiba Corporation, and its subsidiaries and affiliates (collectively "TOSHIBA"), reserve the right to make changes to the information in this document, and related hardware, software and systems (collectively "Product") without notice.
- This document and any information herein may not be reproduced without prior written permission from TOSHIBA. Even with TOSHIBA's written permission, reproduction is permissible only if reproduction is without alteration/omission.
- Though TOSHIBA works continually to improve Product's quality and reliability, Product can malfunction or fail. Customers are responsible for complying with safety standards and for providing adequate designs and safeguards for their hardware, software and systems which minimize risk and avoid situations in which a malfunction or failure of Product could cause loss of human life, bodily injury or damage to property, including data loss or corruption. Before customers use the Product, create designs including the Product, or incorporate the Product into their own applications, customers must also refer to and comply with (a) the latest versions of all relevant TOSHIBA information, including without limitation, this document, the specifications, the data sheets and application notes for Product and the precautions and conditions set forth in the "TOSHIBA Semiconductor Reliability Handbook" and (b) the instructions for the application with which the Product will be used with or for. Customers are solely responsible for all aspects of their own product design or applications, including but not limited to (a) determining the appropriateness of the use of this Product in such design or applications; (b) evaluating and determining the applicability of any information contained in this document, or in charts, diagrams, programs, algorithms, sample application circuits, or any other referenced documents; and (c) validating all operating parameters for such designs and applications. **TOSHIBA ASSUMES NO LIABILITY FOR CUSTOMERS' PRODUCT DESIGN OR APPLICATIONS.**
- Product is intended for use in general electronics applications (e.g., computers, personal equipment, office equipment, measuring equipment, industrial robots and home electronics appliances) or for specific applications as expressly stated in this document. Product is neither intended nor warranted for use in equipment or systems that require extraordinarily high levels of quality and/or reliability and/or a malfunction or failure of which may cause loss of human life, bodily injury, serious property damage or serious public impact ("Unintended Use"). Unintended Use includes, without limitation, equipment used in nuclear facilities, equipment used in the aerospace industry, medical equipment, equipment used for automobiles, trains, ships and other transportation, traffic signaling equipment, equipment used to control combustions or explosions, safety devices, elevators and escalators, devices related to electric power, and equipment used in finance-related fields. Do not use Product for Unintended Use unless specifically permitted in this document.
- Do not disassemble, analyze, reverse-engineer, alter, modify, translate or copy Product, whether in whole or in part.
- Product shall not be used for or incorporated into any products or systems whose manufacture, use, or sale is prohibited under any applicable laws or regulations.
- The information contained herein is presented only as guidance for Product use. No responsibility is assumed by TOSHIBA for any infringement of patents or any other intellectual property rights of third parties that may result from the use of Product. No license to any intellectual property right is granted by this document, whether express or implied, by estoppel or otherwise.
- **ABSENT A WRITTEN SIGNED AGREEMENT, EXCEPT AS PROVIDED IN THE RELEVANT TERMS AND CONDITIONS OF SALE FOR PRODUCT, AND TO THE MAXIMUM EXTENT ALLOWABLE BY LAW, TOSHIBA (1) ASSUMES NO LIABILITY WHATSOEVER, INCLUDING WITHOUT LIMITATION, INDIRECT, CONSEQUENTIAL, SPECIAL, OR INCIDENTAL DAMAGES OR LOSS, INCLUDING WITHOUT LIMITATION, LOSS OF PROFITS, LOSS OF OPPORTUNITIES, BUSINESS INTERRUPTION AND LOSS OF DATA, AND (2) DISCLAIMS ANY AND ALL EXPRESS OR IMPLIED WARRANTIES AND CONDITIONS RELATED TO SALE, USE OF PRODUCT, OR INFORMATION, INCLUDING WARRANTIES OR CONDITIONS OF MERCHANTABILITY, FITNESS FOR A PARTICULAR PURPOSE, ACCURACY OF INFORMATION, OR NONINFRINGEMENT.**
- Do not use or otherwise make available Product or related software or technology for any military purposes, including without limitation, for the design, development, use, stockpiling or manufacturing of nuclear, chemical, or biological weapons or missile technology products (mass destruction weapons). Product and related software and technology may be controlled under the Japanese Foreign Exchange and Foreign Trade Law and the U.S. Export Administration Regulations. Export and re-export of Product or related software or technology are strictly prohibited except in compliance with all applicable export laws and regulations.
- Please contact your TOSHIBA sales representative for details as to environmental matters such as the RoHS compatibility of Product. Please use Product in compliance with all applicable laws and regulations that regulate the inclusion or use of controlled substances, including without limitation, the EU RoHS Directive. TOSHIBA assumes no liability for damages or losses occurring as a result of noncompliance with applicable laws and regulations.