

Cree® P4 LED CP41B-WES/WGS Data Sheet

This revolutionary package design allows the lighting designer to reduce the number of LEDs required and provide a more uniform and unique illuminated appearance than with other LED solutions.

This is possible through the efficient optical-package design and high-current capabilities. The low-profile package can be easily coupled with reflectors or lenses to efficiently distribute light and provide the desired lit appearance. This product family employs green and blue LED materials, which allows designers to match the color of many lighting applications such as vehicle signal lamps and amusement lighting.



FEATURES

- Size (mm): 7.6 x 7.6
- Color Temperatures (K):
 - » Cool White: Min. (4600) / Typical (9000)
- Luminous Flux (lm)
 - » CP41B-WES (3850-11000)
 - » CP41B-WGS (3850-11000)
- Viewing Angle:
 - » CP41B-WES: 60 degrees
 - » CP41B-WGS: 90 degrees
- Lead-Free
- RoHS-Compliant

APPLICATIONS

- Channel Letter
- Amusement



Absolute Maximum Ratings ($T_A = 25^\circ\text{C}$)

Items	Symbol	Absolute Maximum Rating	Unit
		CP41B-WES/WGS	
Forward Current	I_F	35	mA
Peak Forward Current ^{Note}	I_{FP}	100	mA
Reverse Voltage	V_R	5	V
Power Dissipation	P_D	154	mW
Operation Temperature	T_{opr}	-40 ~ +95	$^\circ\text{C}$
Storage Temperature	T_{stg}	-40 ~ +100	$^\circ\text{C}$
Lead Soldering Temperature	T_{sol}	Max. 260 $^\circ\text{C}$ for 3 sec. max. (3 mm from the base of the epoxy bulb)	

Note: Pulse width ≤ 0.1 msec, duty $\leq 1/10$.

Typical Electrical & Optical Characteristics ($T_A = 25^\circ\text{C}$)

Characteristics		Symbol	Condition	Unit	Minimum	Typical	Maximum
Forward Voltage	CP41B-WES/WGS	V_F	$I_F = 30$ mA	V		3.6	4.4
Reverse Current	CP41B-WES/WGS	I_R	$V_R = 5$ V	μA			100
Luminous Flux	CP41B-WES/WGS	Φ_v	$I_F = 30$ mA	mlm	3850	7000	
Luminous Intensity	CP41B-WES	I_v	$I_F = 30$ mA	mcd		5200	
	CP41B-WGS	I_v	$I_F = 30$ mA	mcd		3000	
Chromaticity Coordinates	CP41B-WES/WGS	x	$I_F = 30$ mA			0.2895	
	CP41B-WES/WGS	y	$I_F = 30$ mA			0.2905	
50% Power Angle	CP41B-WES	$2\theta_{1/2}$	$I_F = 30$ mA	deg		60	
	CP41B-WGS	$2\theta_{1/2}$	$I_F = 30$ mA	deg		90	



Flux Bin Limit ($I_F = 30 \text{ mA}$)

Cool White (CP41B-WES/WGS)

Bin Code	Min.(mlm)	Max.(mlm)
K0	3850	4400
L0	4400	5500
M0	5500	6600
N0	6600	8730
P0	8730	11000

Tolerance of measurement of luminous flux is $\pm 15\%$.

VF Bin Limit ($I_F = 30 \text{ mA}$)

Cool White (CP41B-WES/WGS)

Bin Code	Min.(V)	Max.(V)
27	2.8	3.0
28	3.0	3.2
29	3.2	3.4
2a	3.4	3.6
2b	3.6	3.8
2c	3.8	4.0
2d	4.0	4.2
2e	4.2	4.4

Tolerance of measurement of VF is $\pm 0.05 \text{ V}$.

Color Bin Limit ($I_F = 30 \text{ mA}$)

Bin Code	Sub-bin	x	y
W1	Wa	0.2545	0.2480
		0.2633	0.2410
		0.2545	0.2245
		0.2450	0.2290
	Wb	0.2633	0.2410
		0.2720	0.2340
		0.2640	0.2200
		0.2545	0.2245
	Wc	0.2545	0.2480
		0.2640	0.2670
		0.2720	0.2575
		0.2633	0.2410
	Wd	0.2633	0.2410
		0.2720	0.2575
		0.2800	0.2480
		0.2720	0.2340
W2	We	0.2640	0.2670
		0.2735	0.2860
		0.2808	0.2740
		0.2720	0.2575
	Wf	0.2720	0.2575
		0.2808	0.2740
		0.2880	0.2620
		0.2800	0.2480
	Wg	0.2735	0.2860
		0.2830	0.3050
		0.2895	0.2905
		0.2808	0.2740
	Wh	0.2808	0.2740
		0.2895	0.2905
		0.2960	0.2760
		0.2880	0.2620

Bin Code	Sub-bin	x	y
W3	Wj	0.2830	0.3050
		0.2950	0.3210
		0.2998	0.3028
		0.2895	0.2905
	Wk	0.2895	0.2905
		0.2998	0.3028
		0.3045	0.2865
		0.2960	0.2760
	Wm	0.2950	0.3210
		0.3070	0.3370
		0.3100	0.3150
		0.2998	0.3028
	Wn	0.2998	0.3028
		0.3100	0.3150
		0.3130	0.2970
		0.3045	0.2865
W4	Wp	0.3070	0.3370
		0.3185	0.3485
		0.3200	0.3270
		0.3100	0.3150
	Wq	0.3100	0.3150
		0.3200	0.3270
		0.3215	0.3075
		0.3130	0.2970
	Wr	0.3185	0.3485
		0.3300	0.3600
		0.3300	0.3390
		0.3200	0.3270
	Ws	0.3200	0.3270
		0.3300	0.3390
		0.3300	0.3180
		0.3215	0.3075

Bin Code	Sub-bin	x	y
W5	Wt	0.3300	0.3600
		0.3455	0.3725
		0.3443	0.3535
		0.3300	0.3390
	Wu	0.3300	0.3390
		0.3443	0.3535
		0.3430	0.3345
		0.3300	0.3180
	Wv	0.3455	0.3725
		0.3610	0.3850
		0.3585	0.3680
		0.3443	0.3535
	Ww	0.3443	0.3535
		0.3585	0.3680
		0.3560	0.3510
		0.3430	0.3345

Tolerance of measurement of the color coordinates is ± 0.01 .

CIE Chromaticity Diagram

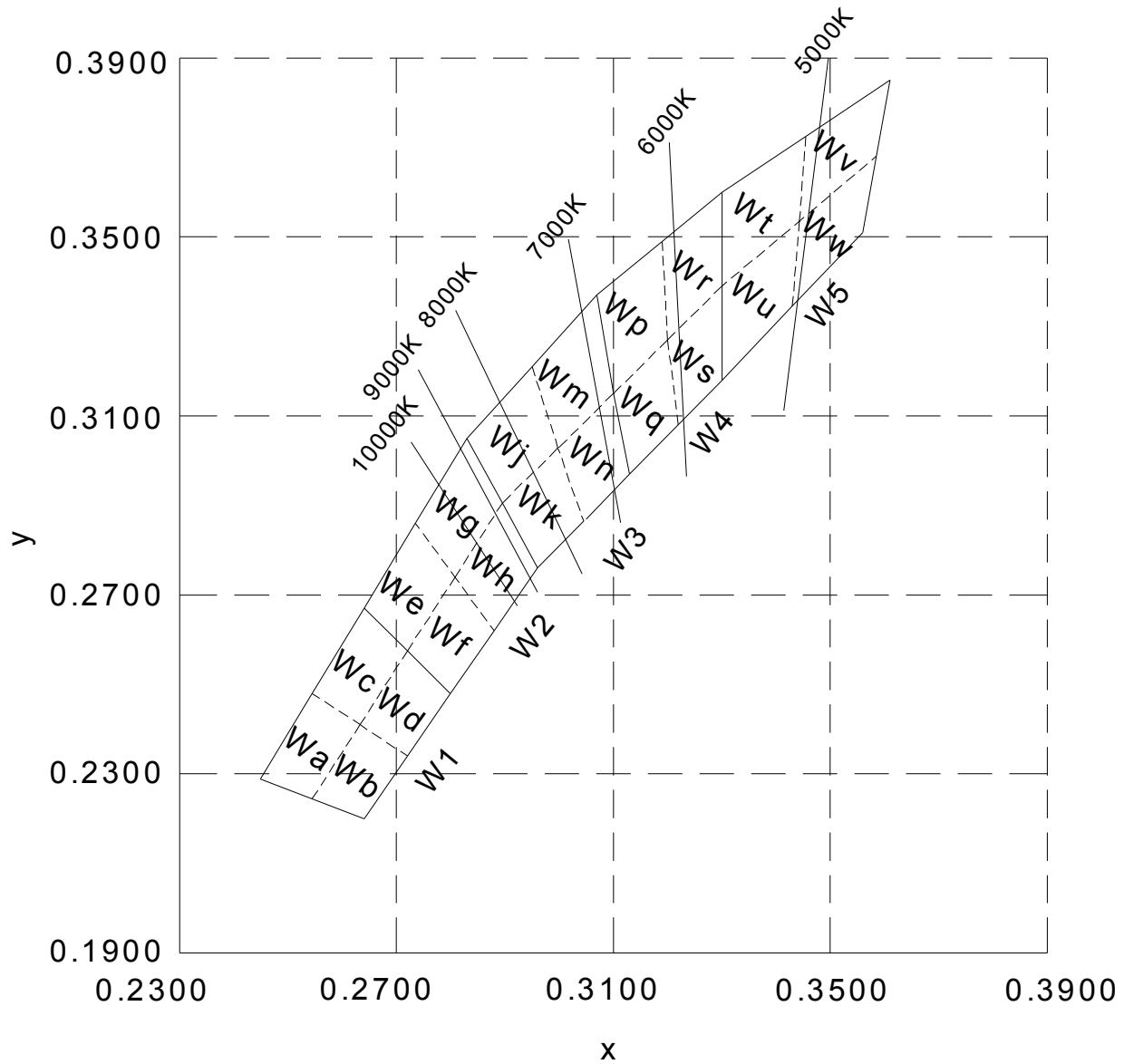



Order Code Table*

60 degrees

Color	Kit Number	Viewing Angle	Luminous Flux (lm)		Color Bin Code
			Min.	Max.	
Cool White	CP41B-WES-CK0P0154	60	3850	11000	W1,W2,W3,W4,W5
Cool White	CP41B-WES-CL0P0134	60	4400	11000	W1,W2,W3
Cool White	CP41B-WES-CM0P0134	60	5500	11000	W1,W2,W3
Cool White	CP41B-WES-CM0P0234	60	5500	11000	W2,W3
Cool White	CP41B-WES-CM0P0244	60	5500	11000	W2,W3,W4
Cool White	CP41B-WES-CN0P0134	60	6600	11000	W1,W2,W3

90 degrees

Color	Kit Number	Viewing Angle	Luminous Flux (lm)		Color Bin Code
			Min.	Max.	
Cool White	CP41B-WGS-CK0P0154	90	3850	11000	W1,W2,W3,W4,W5
Cool White	CP41B-WGS-CL0P0134	90	4400	11000	W1,W2,W3
Cool White	CP41B-WGS-CM0P0134	90	5500	11000	W1,W2,W3
Cool White	CP41B-WGS-CM0P0234	90	5500	11000	W2,W3
Cool White	CP41B-WGS-CM0P0244	90	5500	11000	W2,W3,W4
Cool White	CP41B-WGS-CN0P0134	90	6600	11000	W1,W2,W3

Notes:

- The above kit numbers represent order codes that include multiple flux-bin and color-bin codes. Only one flux-bin code and one color-bin code will be shipped on each tube. And single flux-bin code and single color-bin codes will not be orderable.
- Please refer to the "Cree LED Lamp Reliability Test Standards" document for reliability test conditions.
- Please refer to the "Cree LED Lamp Soldering & Handling" document for information about how to use this LED product safely.

Graphs

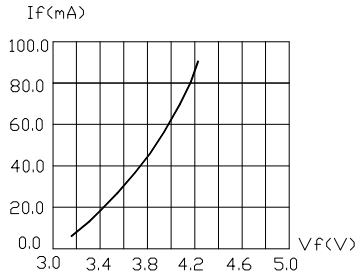

FIG.1 FORWARD CURRENT VS. FORWARD VOLTAGE

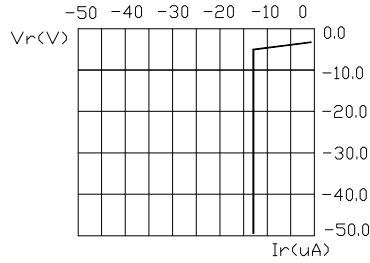

FIG.2 REVERSE CURRENT VS. REVERSE VOLTAGE

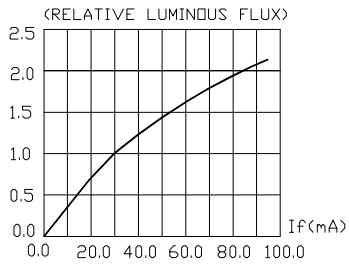

FIG.3 RELATIVE LUMINOUS FLUX VS. FORWARD CURRENT

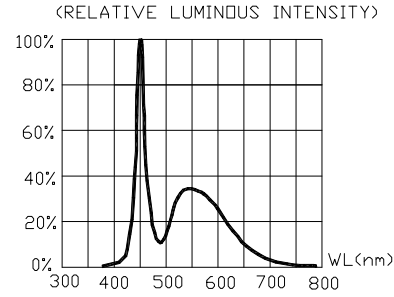

FIG.4 RELATIVE LUMINOUS INTENSITY VS. WAVELENGTH.

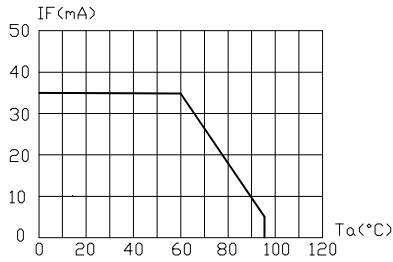

FIG.5 MAXIMUM FORWARD CURRENT VS. AMBIENT TEMPERATURE ($T_{jmax}=120^{\circ}C$)

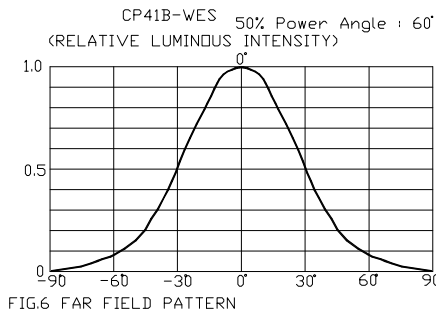

FIG.6 FAR FIELD PATTERN

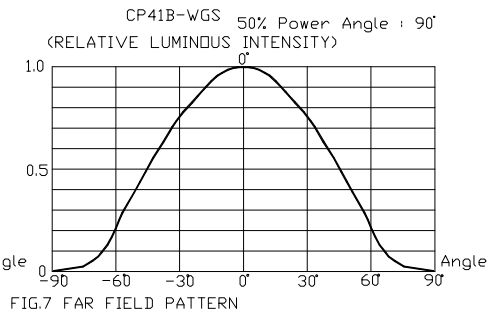

FIG.7 FAR FIELD PATTERN

The above data are collected from statistical figures that do not necessarily correspond to the actual parameters of each single LED. Hence, these data will be changed without further notice.

Mechanical Dimensions

All dimensions are in mm. Tolerance is ± 0.25 mm unless otherwise noted.

An epoxy meniscus may extend about 1.5 mm down the leads.

Burr around bottom of epoxy may be 0.5 mm max.

CP41B-WES:

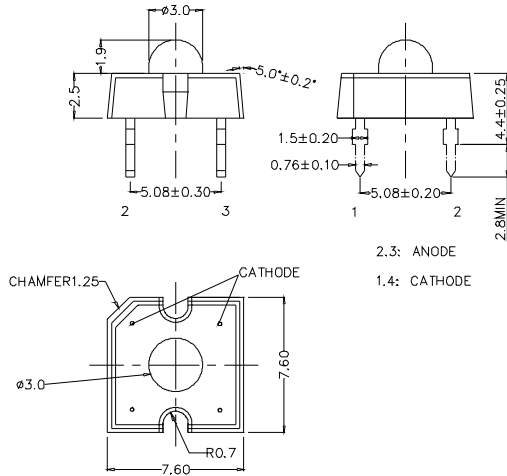

CP41B-WGS:

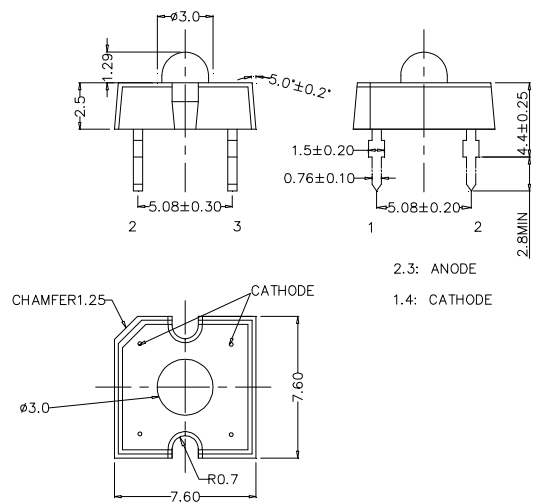

Notes

RoHS Compliance

The levels of environmentally sensitive, persistent biologically toxic (PBT), persistent organic pollutants (POP), or otherwise restricted materials in this product are below the maximum concentration values (also referred to as the threshold limits) permitted for such substances, or are used in an exempted application, in accordance with EU Directive 2002/95/EC on the restriction of the use of certain hazardous substances in electrical and electronic equipment (RoHS), as amended through April 21, 2006.

Vision Advisory Claim

Users should be cautioned not to stare at the light of this LED product. The bright light can damage the eye.



Kit Number System

Cree LED lamps are tested and sorted into performance bins. A bin is specified by ranges of color, forward voltage, and brightness. Sorted LEDs are packaged for shipping in various convenient options. Please refer to the "Cree LED Lamp Packaging Standard" document for more information about shipping and packaging options.

Cree LEDs are sold by order codes in combinations of bins called kits. Order codes are configured in the following manner:

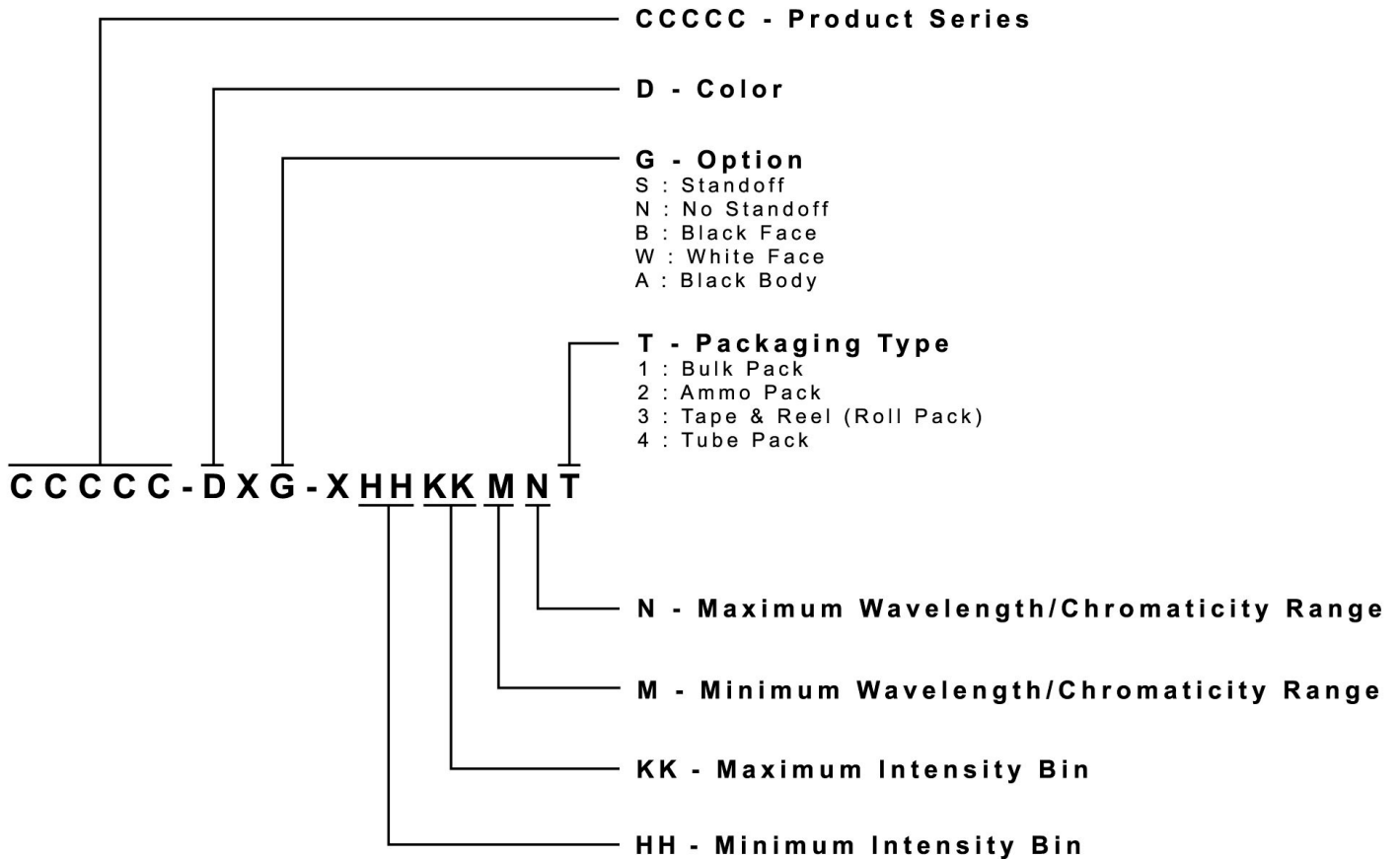

Package

Features:

- The LEDs are packed in cardboard boxes after packaging in normal or anti-electrostatic bags.
- Cardboard boxes will be used to protect the LEDs from mechanical shock during transportation.
- The boxes are not water-resistant, and they must be kept away from water and moisture.
- The Tube Pack type of packaging.
- Max 60 pcs per tube.

