

### OVERVIEW

The 8707E/F are dual-PLL clock generator ICs, using a 27MHz master clock, that generate independent audio clock, video clock, and signal processor clock outputs needed in DVD player/recorder applications. Each PLL loop filter and crystal oscillator circuit are built-in and require no external components, resulting in high-precision clocks. The lineup includes devices that support both 44.1/48kHz audio sampling frequencies (fs), switchable using a control pin. The sampling frequency can be switched during operation without generating any output spike noise.

### FEATURES

- Supply voltage: 3.0 to 3.6V
- Low current consumption: 35mA typ.  
( $V_{DD}=3.3V$ , all outputs with no load)
- 27MHz master clock  
(internal PLL reference clock)
- Generated clocks
- PLL loop filter built-in
- Crystal oscillator circuit built-in
- Sampling frequency fs: 44.1/48kHz
- 16-pin VSOP package (Pb free)

	SM8707E	SM8707F
Video system output	27.0000MHz	27.0000MHz
Audio system output	512fs	768fs
Signal processor system output	33.8688MHz	16.9344MHz
	33.8688MHz	33.8688MHz

- Low jitter output (1-sigma output load capacitance typical values)

	SM8707E	SM8707F
Video system output	20ps	20ps
Audio and Signal processor system output	55ps	40ps

### APPLICATIONS

- DVD players/recorders
- DVD car navigation system

### ORDERING INFORMATION

Device	Package
SM8707EV	16pin VSOP
SM8707FV	

### PACKAGE DIMENSIONS

(Unit : mm)

Weight: 0.07g

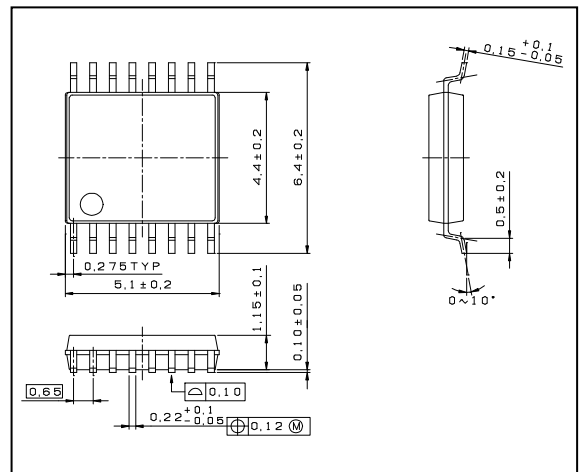

**PINOUT**

(Top view)

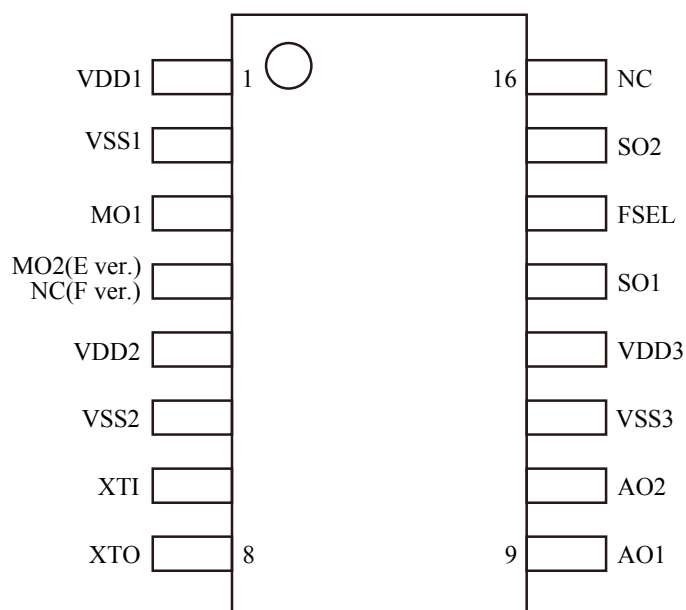
**PIN DESCRIPTION**

No.	Name	I/O	Description
1	VDD1	-	Supply for digital block
2	VSS1	-	Ground for digital block
3	MO1	O	Video system output
4	MO2(E ver.)	O	Video system output
	NC(F ver.)	-	Non connection output (leave pin open circuit)
5	VDD2	-	Supply for analog block
6	VSS2	-	Ground for analog block
7	XTI	I	Crystal oscillator connection or external clock input
8	XTO	O	Crystal oscillator connection
9	AO1	O	Audio system output
10	AO2	O	Audio system output
11	VSS3	-	Ground for digital block
12	VDD3	-	Supply for digital block
13	SO1	O	Signal processor system output
14	FSEL	I	Sampling frequency select
15	SO2	O	Signal processor system output
16	NC	-	Non connection (leave pin open circuit or connect to VDD)

BLOCK DIAGRAM

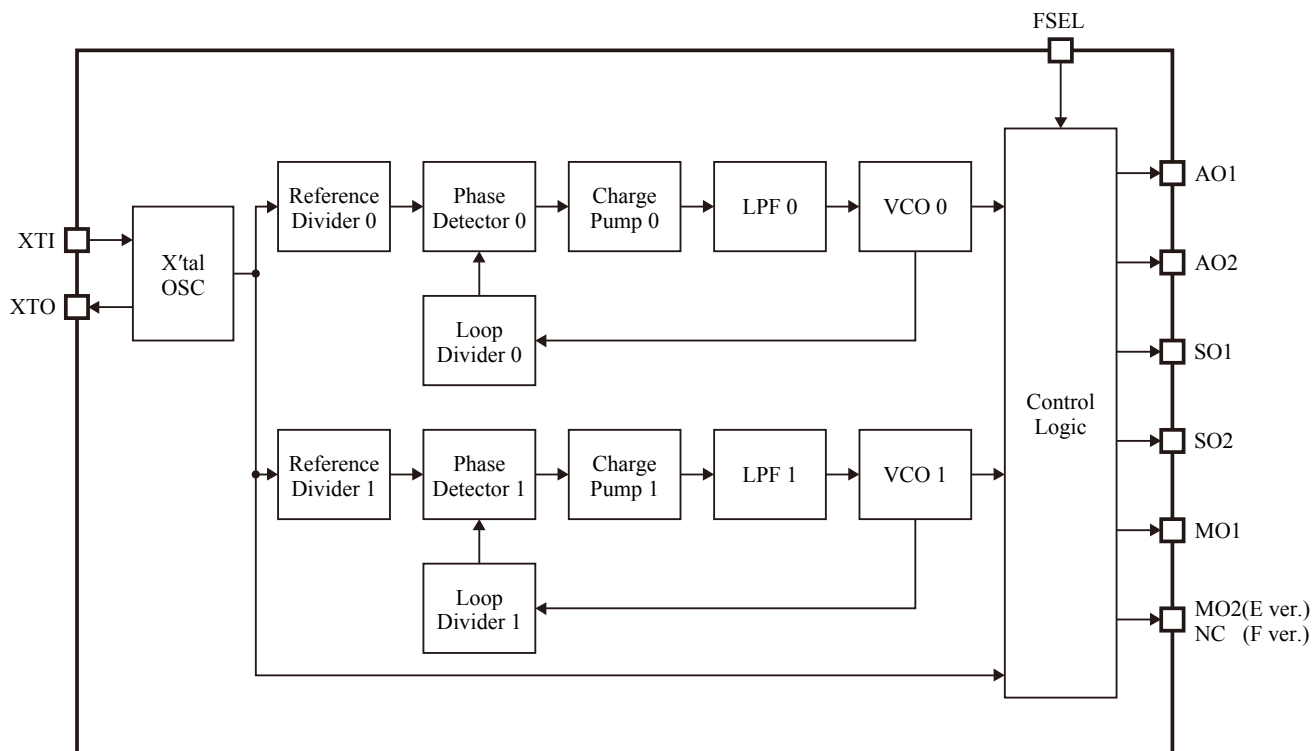

## SM8707E/F

Note: Unless otherwise noted, VDD applies to VDD1, VDD2, and VDD3. Similarly, VSS applies to VSS1, VSS2, and VSS3.

### SPECIFICATIONS

#### Absolute Maximum Ratings

Parameter	Symbol	Rating	Unit
Supply voltage range	$V_{DD1}, V_{DD2}, V_{DD3}$	-0.3 to +6.5	V
Supply voltage deviation	$V_{DD1}-V_{DD2}, V_{DD1}-V_{DD3},$ $V_{DD2}-V_{DD3}$	$\pm 0.1$	V
Input voltage range	$V_{IN}$	-0.3 to $V_{DD}+0.3$	V
Output voltage range	$V_{OUT}$	-0.3 to $V_{DD}+0.3$	V
Power dissipation	$P_D$	165	mW
Storage temperature range	$T_{STG}$	-55 to +125	°C

#### Recommended Operating Conditions

$V_{SS}=V_{SS1}=V_{SS2}=V_{SS3}=0V$  unless otherwise noted.

##### SM8707E

Parameter	Symbol	Condition	Rating			Unit
			MIN	TYP	MAX	
Supply voltage ranges	$V_{DD1}, V_{DD2}, V_{DD3}$	(Note 1,2,3)	+3.0	-	+3.6	V
Output load capacitance 1	$C_{L1}$	MO1 output	-	-	40	pF
Output load capacitance 2	$C_{L2}$	MO2 output	-	-	25	pF
Output load capacitance 3	$C_{L3}$	SO1,SO2,AO1,AO2 outputs	-	-	15	pF
Master clock frequency	$f_{XTAL}$	When using crystal oscillator	-	27.0000	-	MHz
Operating temperature range	$T_{OPR}$		-10	-	+75	°C

##### SM8707F

Parameter	Symbol	Condition	Rating			Unit
			MIN	TYP	MAX	
Supply voltage ranges	$V_{DD1}, V_{DD2}, V_{DD3}$	(Note 1,2,3)	+3.0	-	+3.6	V
Output load capacitance 1	$C_{L1}$	MO1,SO1,SO2 outputs	-	-	25	pF
Output load capacitance 2	$C_{L2}$	AO1,AO2 outputs	-	-	15	pF
Master clock frequency	$f_{XTAL}$	When using crystal oscillator	-	27.0000	-	MHz
Operating temperature range	$T_{OPR}$		-40	-	+85	°C

Note 1. The supply voltage is defined relative to  $V_{SS}=0V$ .

Note 2. The supply voltages applied on VDD1, VDD2 and VDD3 should be derived from a common supply source.

Note 3. If the supply voltages on VDD1, VDD2 and VDD3 are from different sources, they should be applied simultaneously. The SM8707 may be damaged if the supply voltage timing is different.

## DC Electrical Characteristics

### ■ SM8707E

$f_{XTAL}=27.0000\text{MHz}$ ,  $V_{DD}=3.3\text{V} \pm 0.3\text{V}$ ,  $V_{SS}=0\text{V}$ ,  $T_a=-10$  to  $+75^\circ\text{C}$  unless otherwise noted.

### ■ SM8707F

$f_{XTAL}=27.0000\text{MHz}$ ,  $V_{DD}=3.3\text{V} \pm 0.3\text{V}$ ,  $V_{SS}=0\text{V}$ ,  $T_a=-40$  to  $+85^\circ\text{C}$  unless otherwise noted.

Parameter	Symbol	Pins	Condition	Rating			Unit
				MIN	TYP	MAX	
Current consumption	$I_{DD}$	VDD	$V_{DD}=3.3\text{V}$ , $T_a=25^\circ\text{C}$ , $f_s=48\text{kHz}$ , Crystal oscillator connected, no load on all outputs	-	35	45	mA
Input voltage	$V_{IH}$	FSEL,XTI	$V_{DD}=3.3\text{V}$	$0.8V_{DD}$	-	-	V
	$V_{IL}$			-	-	$0.2V_{DD}$	
Input current	$I_{IH1}$	FSEL *1	$V_{IN}=V_{DD}$	-	-	1	$\mu\text{A}$
	$I_{IL1}$		$V_{IN}=0\text{V}$	-100	-	-	
	$I_{IH2}$	XTI	$V_{IN}=V_{DD}$	-	-	40	
	$I_{IL2}$		$V_{IN}=0\text{V}$	-40	-	-	
Output voltage	$V_{OH}$	All outputs	$I_{OH}=-2\text{mA}$	$V_{DD}-0.4$	-	-	V
	$V_{OL}$	excluding XTO	$I_{OL}=2\text{mA}$	-	-	0.4	

\*1. FSEL pin has Schmitt-trigger input and built-in pull-up resistor.

## AC Electrical Characteristics

## SM8707E

$f_{XTAL}=27.0000\text{MHz}$ ,  $V_{DD}=3.3\text{V}\pm 0.3\text{V}$ ,  $V_{SS}=0\text{V}$ ,  $T_a=-10$  to  $+75^\circ\text{C}$  unless otherwise noted.

Parameter	Symbol	Pins	Condition	Rating			Unit
				MIN	TYP	MAX	
External input clock frequency <sup>*1</sup>	$f_{XTI}$	XTI	Applies to external clock input use only	-	27.0000	-	MHz
Output clock rise time <sup>*2</sup>	$t_r$	MO1	$C_L=40\text{pF}$ , transition between $V_{OL}=0.2V_{DD}$ and $V_{OH}=0.8V_{DD}$	-	2.0	-	ns
		MO2	$C_L=25\text{pF}$ , transition between $V_{OL}=0.2V_{DD}$ and $V_{OH}=0.8V_{DD}$	-	2.0	-	
		SO1,SO2, AO1,AO2	$C_L=15\text{pF}$ , transition between $V_{OL}=0.2V_{DD}$ and $V_{OH}=0.8V_{DD}$	-	2.0	-	
Output clock fall time <sup>*2</sup>	$t_f$	MO1	$C_L=40\text{pF}$ , transition between $V_{OH}=0.8V_{DD}$ and $V_{OL}=0.2V_{DD}$	-	2.0	-	ns
		MO2	$C_L=25\text{pF}$ , transition between $V_{OH}=0.8V_{DD}$ and $V_{OL}=0.2V_{DD}$	-	2.0	-	
		SO1,SO2, AO1,AO2	$C_L=15\text{pF}$ , transition between $V_{OH}=0.8V_{DD}$ and $V_{OL}=0.2V_{DD}$	-	2.0	-	
Output clock jitter <sup>*3</sup>	$t_{\text{jitter}}$ (1-sigma)	MO1	$T_a=25^\circ\text{C}$ , $C_L=40\text{pF}$ , $V_O=0.5V_{DD}$	-	20	-	ps
		MO2	$T_a=25^\circ\text{C}$ , $C_L=25\text{pF}$ , $V_O=0.5V_{DD}$	-	20	-	
		SO1,SO2, AO1,AO2	$T_a=25^\circ\text{C}$ , $C_L=15\text{pF}$ , $V_O=0.5V_{DD}$	-	55	-	
Output clock duty cycle <sup>*2</sup>	Dt	MO1	$T_a=25^\circ\text{C}$ , $C_L=40\text{pF}$ , $V_O=0.5V_{DD}$	45	50	55	%
		MO2	$T_a=25^\circ\text{C}$ , $C_L=25\text{pF}$ , $V_O=0.5V_{DD}$	45	50	55	
		SO1,SO2, AO1,AO2	$T_a=25^\circ\text{C}$ , $C_L=15\text{pF}$ , $V_O=0.5V_{DD}$	45	50	55	
Settling time <sup>*2</sup>	$t_s$	AO1,AO2		-	-	1	$\mu\text{s}$
Power-up time <sup>*2*4</sup>	$t_p$	All outputs excluding XTO		-	1	5	ms

\*1. When using an external clock input, the XTI duty should be 50% with 3.3V clock signal amplitude level. The input signal voltage should not exceed the absolute maximum rating, otherwise damage may occur.

\*2. The numeric values are measured values obtained using the circuit in Figure 1 and the NPC standard evaluation board.

\*3. The numeric values are measured values obtained using the circuit in Figure 2 and the NPC standard evaluation board.

\*4. This is the time, after the supply is turned ON from the OFF state, until the output clock reaches  $\pm 0.1\%$  of the specified frequency.

## SM8707F

$f_{XTAL}=27.0000\text{MHz}$ ,  $V_{DD}=3.3\text{V}\pm 0.3\text{V}$ ,  $V_{SS}=0\text{V}$ ,  $T_a=-40$  to  $+85^\circ\text{C}$  unless otherwise noted.

Parameter	Symbol	Pins	Condition	Rating			Unit
				MIN	TYP	MAX	
External input clock frequency <sup>*1</sup>	$f_{XTI}$	XTI	Applies to external clock input use only	-	27.0000	-	MHz
Output clock rise time <sup>*2</sup>	$t_r$	MO1,SO1, SO2	$C_L=25\text{pF}$ , transition between $V_{OL}=0.2V_{DD}$ and $V_{OH}=0.8V_{DD}$	-	2.0	-	ns
		AO1,AO2	$C_L=15\text{pF}$ , transition between $V_{OL}=0.2V_{DD}$ and $V_{OH}=0.8V_{DD}$	-	2.0	-	
Output clock fall time <sup>*2</sup>	$t_f$	MO1,SO1, SO2	$C_L=25\text{pF}$ , transition between $V_{OH}=0.8V_{DD}$ and $V_{OL}=0.2V_{DD}$	-	2.0	-	ns
		AO1,AO2	$C_L=15\text{pF}$ , transition between $V_{OH}=0.8V_{DD}$ and $V_{OL}=0.2V_{DD}$	-	2.0	-	
Output clock jitter <sup>*3</sup>	$t_{\text{jitter}}$ (1-sigma)	MO1	$T_a=25^\circ\text{C}$ , $C_L=25\text{pF}$ , $V_O=0.5V_{DD}$	-	20	-	ps
		SO1,SO2		-	40	-	
		AO1,AO2	$T_a=25^\circ\text{C}$ , $C_L=15\text{pF}$ , $V_O=0.5V_{DD}$	-	40	-	
Output clock duty cycle <sup>*2</sup>	Dt	MO1,SO1, SO2	$T_a=25^\circ\text{C}$ , $C_L=25\text{pF}$ , $V_O=0.5V_{DD}$	45	50	55	%
		AO1,AO2	$T_a=25^\circ\text{C}$ , $C_L=15\text{pF}$ , $V_O=0.5V_{DD}$	45	50	55	
Settling time <sup>*2</sup>	$t_s$	All outputs excluding XTO		-	-	1	$\mu\text{s}$
Power-up time <sup>*2*4</sup>	$t_p$	All outputs excluding XTO		-	1	5	ms

\*1. When using an external clock input, the XTI duty should be 50% with 3.3V clock signal amplitude level. The input signal voltage should not exceed the absolute maximum rating, otherwise damage may occur.

\*2. The numeric values are measured values obtained using the circuit in Figure 1 and the NPC standard evaluation board.

\*3. The numeric values are measured values obtained using the circuit in Figure 2 and the NPC standard evaluation board.

\*4. This is the time, after the supply is turned ON from the OFF state, until the output clock reaches  $\pm 0.1\%$  of the specified frequency.

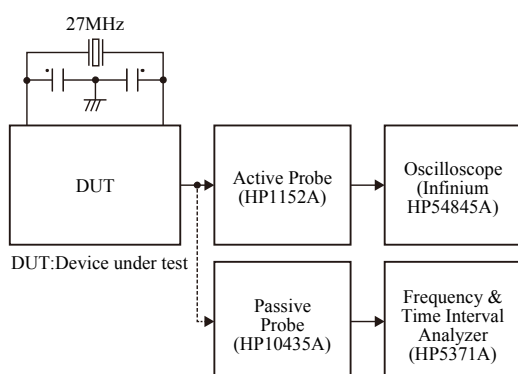

Figure 1. Measurement circuit 1

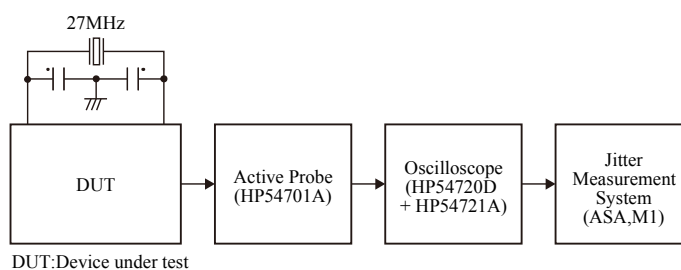

Figure 2. Measurement circuit 2

## FUNCTIONAL DESCRIPTION

### 27MHz Master Clock

The SM8707E/F 27MHz master clock circuit is configured, as shown in Figure 3 with the crystal oscillator element connected between XTI(Pin 7) and XTO(Pin 8).

Alternatively, the 27MHz master clock can be supplied from an external master clock input on XTI, as shown in Figure 4.

If an external input clock on XTI is used, it is recommended that the frequency be 27.0000MHz, with 50% duty, and 3.3V voltage amplitude level.

Furthermore, when using an external clock input, the input signal voltage should not exceed the absolute maximum rating, otherwise damage may occur.

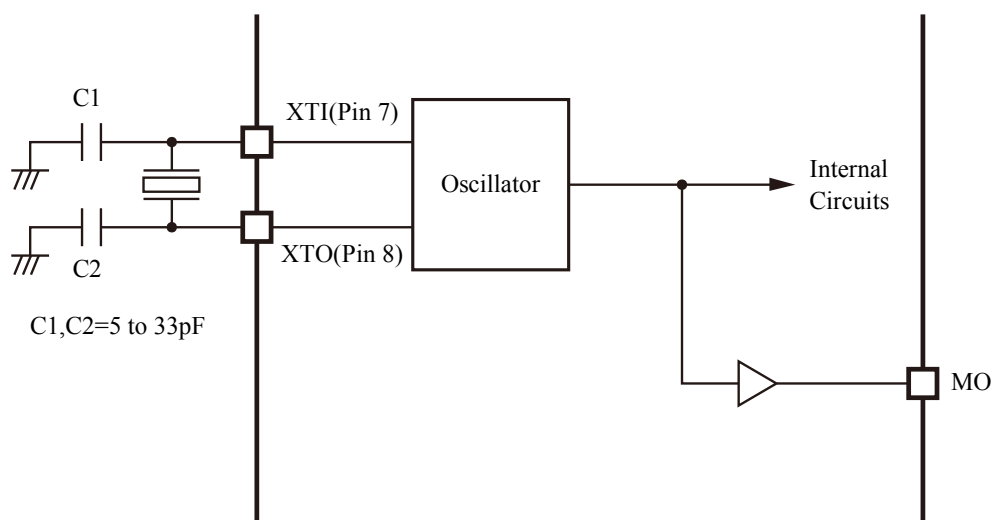

Figure 3. Crystal oscillator connection

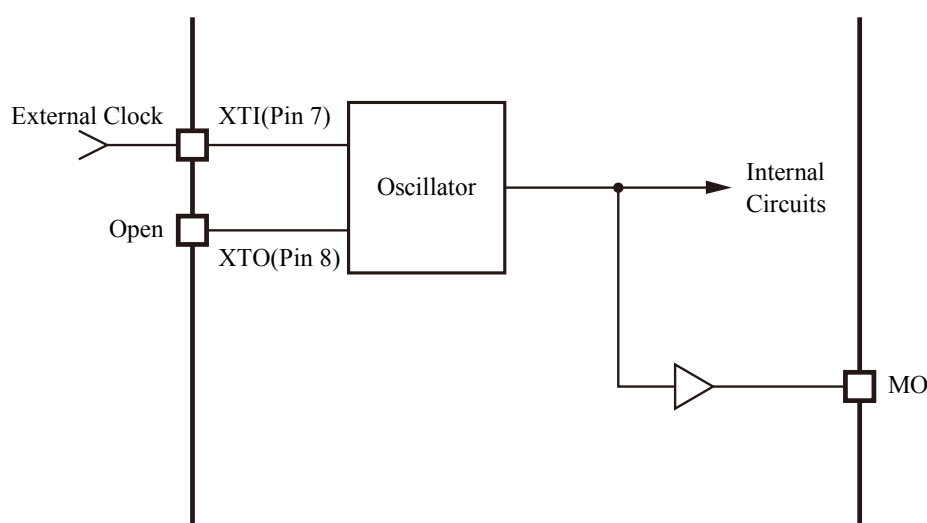

Figure 4. External clock input

## Sampling Frequency and Output Clock Frequency

### SM8707E

The SM8707E sampling frequency  $f_s$  can be switched between 44.1kHz when FSEL(Pin 14) is LOW, and 48kHz when FSEL is HIGH. The audio outputs(AO1 and AO2) are equivalent to 512 $f_s$ , where  $f_s$  is determined by the setting on FSEL. In addition, the signal processor outputs(SO1 and SO2) are 33.8688MHz clocks derived from the master clock. And the video outputs(MO1 and MO2) are 27MHz clocks, identical to the master clock.

The SM8707E supported clock frequencies are shown in Table 1.

FSEL (Pin 14)	Sampling frequency $f_s$ [kHz]	Output clock frequency [MHz]					
		AO1 (Pin 9)	AO2 (Pin 10)	SO1 (Pin 13)	SO2 (Pin15)	MO1 (Pin 3)	MO2 (Pin 4)
HIGH	48	24.5760 (512 $f_s$ )	24.5760 (512 $f_s$ )	33.8688	33.8688	27.0000	27.0000
LOW	44.1	22.5792 (512 $f_s$ )	22.5792 (512 $f_s$ )	33.8688	33.8688	27.0000	27.0000

Table 1. Sampling frequency and output clock frequency (27.0000MHz master clock frequency)

### SM8707F

The SM8707F sampling frequency  $f_s$  can be switched between 44.1kHz when FSEL(Pin 14) is HIGH, and 48kHz when FSEL is LOW. The audio outputs(AO1 and AO2) are equivalent to 768 $f_s$ , where  $f_s$  is determined by the setting on FSEL. In addition, the signal processor outputs(SO1 and SO2) are 16.9344MHz and 33.8688MHz clocks, respectively, derived from the master clock. The video output (MO1) is a 27MHz clock, identical to the master clock.

The SM8707F supported clock frequencies are shown in Table 2.

FSEL (Pin 14)	Sampling frequency $f_s$ [kHz]	Output clock frequency [MHz]				
		AO1 (Pin 9)	AO2 (Pin 10)	SO1 (Pin 13)	SO2 (Pin15)	MO1 (Pin 3)
HIGH	44.1	33.8688 (768 $f_s$ )	33.8688 (768 $f_s$ )	16.9344	33.8688	27.0000
LOW	48	36.8640 (768 $f_s$ )	36.8640 (768 $f_s$ )	16.9344	33.8688	27.0000

Table 2. Sampling frequency and output clock frequency (27.0000MHz master clock frequency)

### Spike Noise Prevention Function

SM8707E/F have a spike noise prevention circuit that prevents any spike noise generation in the audio output clocks when the sampling frequency is switched using FSEL.

The state of the AOx output before and after FSEL is switched is shown in Figure 5.

When FSEL is switched, either from LOW to HIGH or HIGH to LOW, the spike noise prevention circuit stops the AOx clock output by a maximum of 1μs, and then the output clock changes to reflect the current FSEL setting.

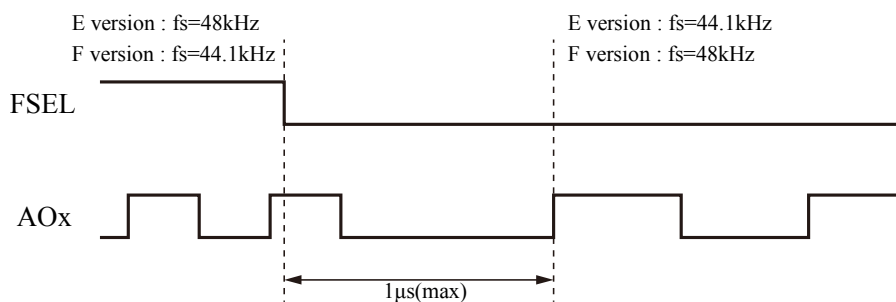

Figure 5. Spike noise prevention circuit timing at sampling frequency switching

### Sampling Frequency Switching Settling Time

The clock output response when the sampling frequency is switched using FSEL is shown in Figure 6. SM8707E/F have a spike noise prevention circuit which stops the output AOx clocks for a fixed interval, which means the settling time is a maximum 1μs when the sampling frequency is switched.

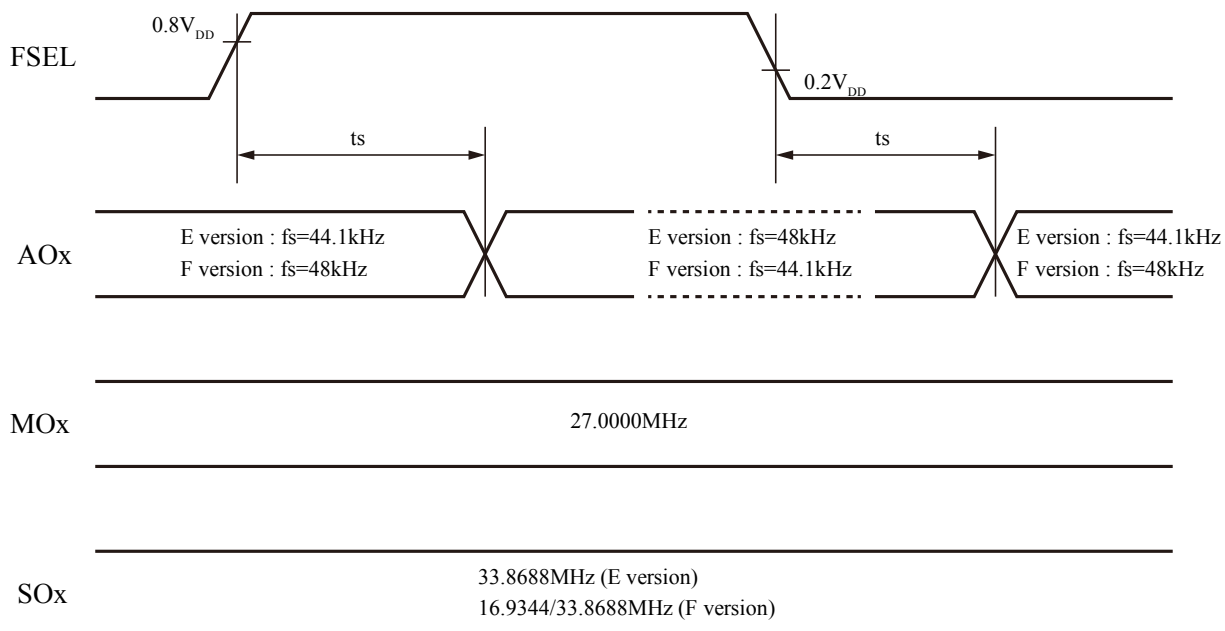

Figure 6. Output signal switching timing

## SM8707E/F OUTPUT FREQUENCY LISTING

Version	FSEL polarity (Pin 14)	Sampling frequency fs [kHz]	Output clock frequency [MHz]					
			Pin 3	Pin 4	Pin 9	Pin 10	Pin 13	Pin 15
SM8707E	H	48.0	27.0000	27.0000	24.5760 (512fs)	24.5760 (512fs)	33.8688	33.8688
	L	44.1	27.0000	27.0000	22.5792 (512fs)	22.5792 (512fs)	33.8688	33.8688
	Output load capacitance [pF]		40	25	15	15	15	15
	Pin name		MO1	MO2	AO1	AO2	SO1	SO2
SM8707F	H	44.1	27.0000	-	33.8688 (768fs)	33.8688 (768fs)	16.9344	33.8688
	L	48.0	27.0000		36.8640 (768fs)	36.8640 (768fs)	16.9344	33.8688
	Output load capacitance [pF]		25	-	15	15	25	25
	Pin name		MO1	NC	AO1	AO2	SO1	SO2

Please pay your attention to the following points at time of using the products shown in this document.

1. The products shown in this document (hereinafter "Products") are designed and manufactured to the generally accepted standards of reliability as expected for use in general electronic and electrical equipment, such as personal equipment, machine tools and measurement equipment. The Products are not designed and manufactured to be used in any other special equipment requiring extremely high level of reliability and safety, such as aerospace equipment, nuclear power control equipment, medical equipment, transportation equipment, disaster prevention equipment, security equipment. The Products are not designed and manufactured to be used for the apparatus that exerts harmful influence on the human lives due to the defects, failure or malfunction of the Products. If you wish to use the Products in that apparatus, please contact our sales section in advance.  
In the event that the Products are used in such apparatus without our prior approval, we assume no responsibility whatsoever for any damages resulting from the use of that apparatus.
2. NPC reserves the right to change the specifications of the Products in order to improve the characteristics or reliability thereof.
3. The information described in this document is presented only as a guide for using the Products. No responsibility is assumed by us for any infringements of patents or other rights of the third parties which may result from its use. No license is granted by implication or otherwise under any patents or other rights of the third parties. Then, we assume no responsibility whatsoever for any damages resulting from that infringements.
4. The constant of each circuit shown in this document is described as an example, and it is not guaranteed about its value of the mass production products.
5. In the case of that the Products in this document falls under the foreign exchange and foreign trade control law or other applicable laws and regulations, approval of the export to be based on those laws and regulations are necessary. Customers are requested appropriately take steps to obtain required permissions or approvals from appropriate government agencies.



SEIKO NPC CORPORATION

1-9-9, Hatchobori, Chuo-ku,  
Tokyo 104-0032, Japan  
Telephone: +81-3-5541-6501  
Facsimile: +81-3-5541-6510  
<http://www.npc.co.jp/>  
Email:sales@npc.co.jp

ND12003-E-00 2012.1