

OVERVIEW

The SM8142B is a transformer-less electroluminescent (EL) driver IC, capable of driving sheets up to 30cm² in size. It employs a high-efficiency driver output circuit configuration to control power dissipation. It is available in ultra-small 8-pin SON (Small Outline Non-leaded) packages*, making possible the construction of small, thin, low-power driver units.

* : SM8142BD

FEATURES

- Dedicated EL driver
- Noise-less smooth drive waveform
- High-efficiency output circuit
- Stand-by function
- Stable temperature characteristics
- Ultra-small package
- 1.6 to 5.5V supply voltage
- 0.3mA typ. ($V_{DD}=3.0V$) current consumption (excluding coil current)
- 200V_{p-p} maximum EL driver voltage
- 31 to 1000Hz EL driver frequency range
- 220μH minimum coil inductance

ORDERING INFORMATION

Device	Package
SM8142BD	8 pin SON
SM8142BV	8 pin VSOP

PACKAGE DIMENSIONS (Unit : mm)

▪ 8-pin SON

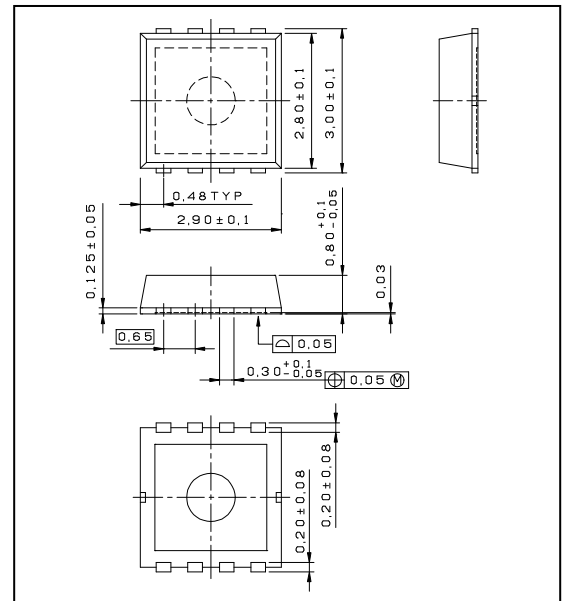

▪ 8-pin VSOP

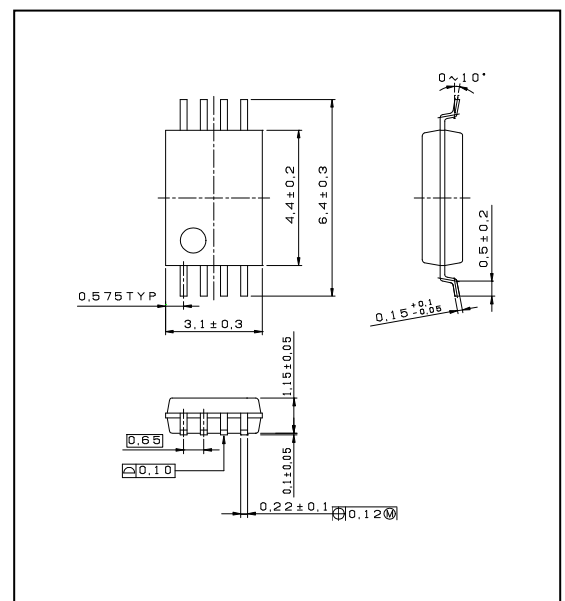

PINOUT (Top view)

▪ 8-pin SON

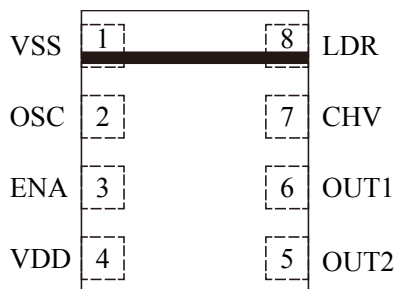

▪ 8-pin VSOP

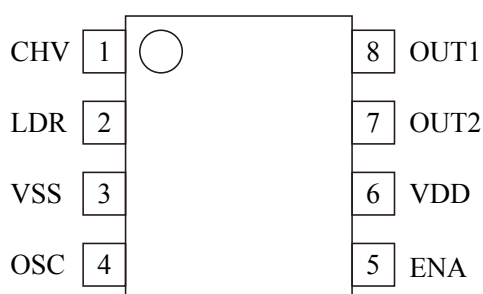

BLOCK DIAGRAM

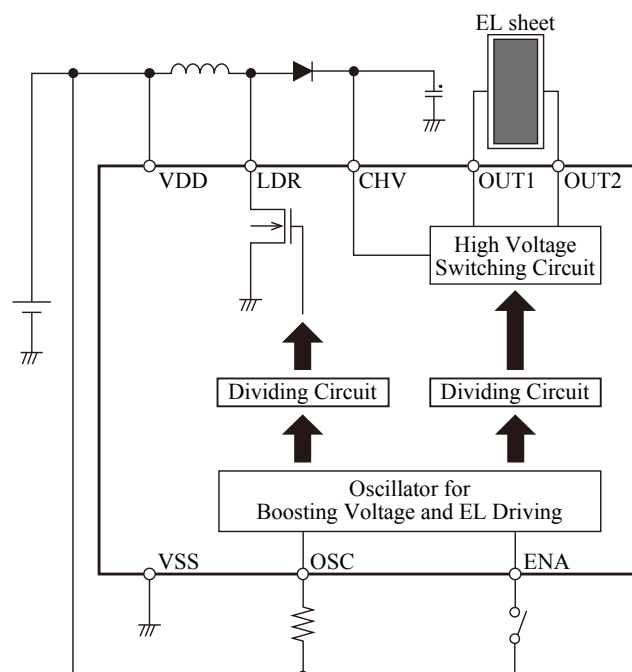

PIN DESCRIPTION

Pin number		Name	I/O	Function
VSOP-8	SON-8			
1	7	CHV	I	High-voltage DC input
2	8	LDR	O	Booster coil driver output
3	1	VSS	-	Ground
4	2	OSC	I	Coil and EL driver oscillator (oscillator frequency determined by external resistor)
5	3	ENA ^{*1}	I	Enable input (High : enable, Low : disable)
6	4	VDD	-	Supply
7	5	OUT2	O	Output 2
8	6	OUT1	O	Output 1

*1. Built-in pull-down resistor

SPECIFICATIONS

Absolute Maximum Ratings

Parameter	Symbol	Condition	Rating	Unit
Supply voltage range	V_{DD}		-0.3 to 7.0	V
Input voltage range	V_{IN}	All input pins	$V_{SS}-0.3$ to $V_{DD}+0.3$	V
Output voltage(CHV)	V_{CHV}	CHV pin	0.5 to 120	V
Output voltage(LDR)	V_{LDR}	LDR pin	0.5 to 120	V
Output voltage(OUT1/2)	$V_{OUT1/2}$	OUT1,OUT2 pin	0.5 to 120	V
Power dissipation	P_D	$T_a \leq 85^\circ\text{C}$	100	mW
Storage temperature range	T_{STG}		-55 to +125	$^\circ\text{C}$

Note. The device may be damaged or deteriorated if any of the above parameter ratings is exceeded.

Recommended Operating Conditions

Parameter	Symbol	Condition	Rating			Unit	
			MIN	TYP	MAX		
Supply voltage range	V_{DD2}		1.6	3.0	5.5	V	
Operating temperature	T_{OPR}		-40	-	85	$^\circ\text{C}$	
Operating current	I_{DD2}	Including coil current, $V_{DD}=3.0\text{V}$	-	-	60^{*1}	mA	
		Including coil current, $V_{DD}=5.0\text{V}$	-	-	36^{*1}		
Current limit resistance	R_{CHV}	$V_{DD} \leq 4.0\text{V}$	0	-	-	k Ω	
		$V_{DD} > 4.0\text{V}$	20	-	-		
	R_{OUT}	$V_{DD} \leq 4.0\text{V}$	EL Size $\leq 30\text{cm}^2$	0	-	-	k Ω
			EL Size $> 30\text{cm}^2$	1.0	-	-	
$V_{DD} > 4.0\text{V}$	EL Size $\leq 30\text{cm}^2$	0	-	1.0			
	EL Size $> 30\text{cm}^2$	1.0^{*2}	-	1.0^{*2}			
Coil inductance	L_{LDR}	$f_{LDR}=64\text{kHz}$	-	470	-	μH	

*1. When it is designed, these ratings should not be exceeded, including device variations.

*2. These values should be fixed at 1.0k Ω .

DC Characteristics

$V_{DD}=3.0V$, $T_a=25^{\circ}C$ unless otherwise noted.

Parameter	Pin	Symbol	Condition	Rating			Unit
				MIN	TYP	MAX	
Supply voltage	VDD	V_{DD}		1.6	3.0	5.5	V
Output voltage	CHV	V_{CHV}		0.5	-	100	V
	OUT1/2	V_{OUTH}		-	-	100	V
	OUT1/2	V_{OUTL}		-	-	0.5	V
Output resistance	LDR	R_{LDR}	$I_{LDR}=50mA$	-	8.0	12.0	Ω
Oscillator frequency	OSC	f_{OSC1}	$R_{OSC}=180k\Omega$	205	256	307	kHz
Oscillator frequency range		f_{OSC2}		32	-	1024	kHz
Output frequency ^{*1}	OUT1/2	f_{OUT1}	$R_{OSC}=180k\Omega$	200	250	300	Hz
Output frequency range		f_{OUT2}		31	-	1000	Hz
Inductance driver frequency ^{*1}	LDR	f_{LDR1}	$R_{OSC}=180k\Omega$	51	64	77	kHz
Inductance driver frequency range		f_{LDR2}		8	-	256	kHz
HIGH-level input voltage	ENA	V_{ENAH}	ENA="H" $V_{DD}=1.6$ to $5.5V$	$V_{DD}-0.5$	-	$V_{DD}+0.3$	V
LOW-level input voltage		V_{ENAL}	ENA="L" $V_{DD}=1.6$ to $5.5V$	$V_{SS}-0.3$	-	$V_{SS}+0.5$	V
Input current	ENA	I_{ENAH}	$V_{ENAH}=V_{DD}=3.0V$	2.0	4.0	6.0	μA
Rise time ^{*2}	ENA	t_{ENA}	$V_{ENAL} \rightarrow V_{ENAH}$	-	-	100	ms
Operating current	VDD	I_{DD1}	Excluding coil current	-	-	0.5	mA
Stand-by current	VDD	I_{STB}	ENA="L"	-	-	1.0	μA

*1. Output frequency=(1/256)×Inductance driver frequency

*2. Rise time

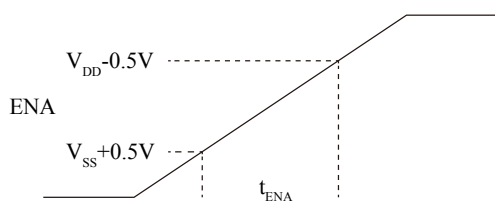

TYPICAL APPLICATIONS

- (1) EL sheet size : 20 to 30cm²
 Current consumption : 20mA

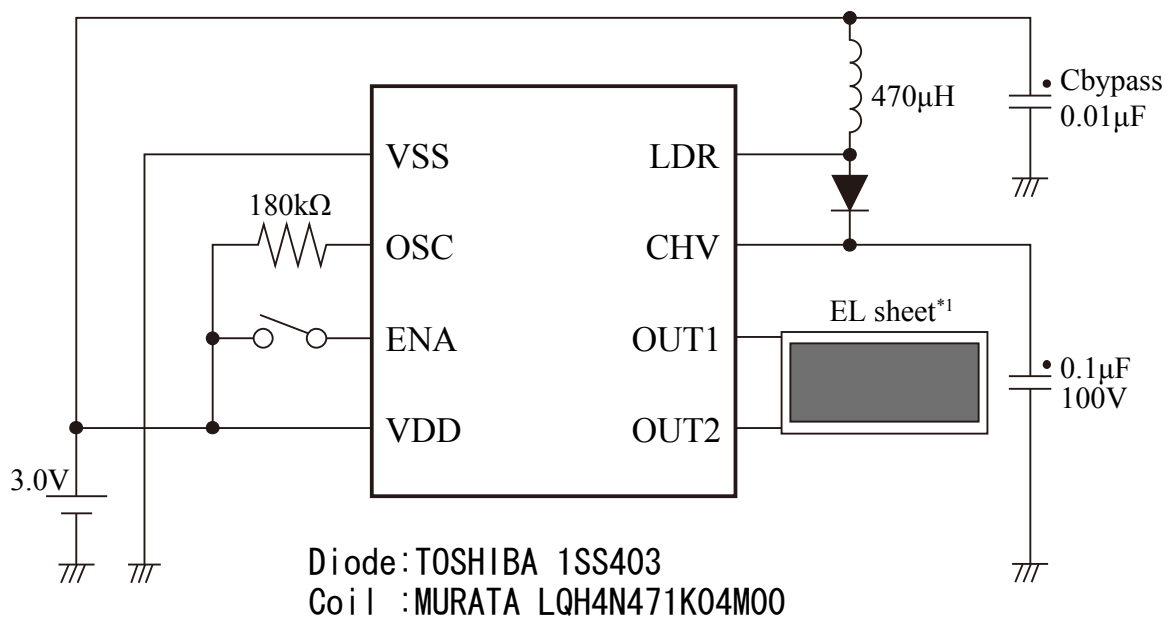

- (2) EL sheet size : 30 to 50cm² *2
 Current consumption : 40mA

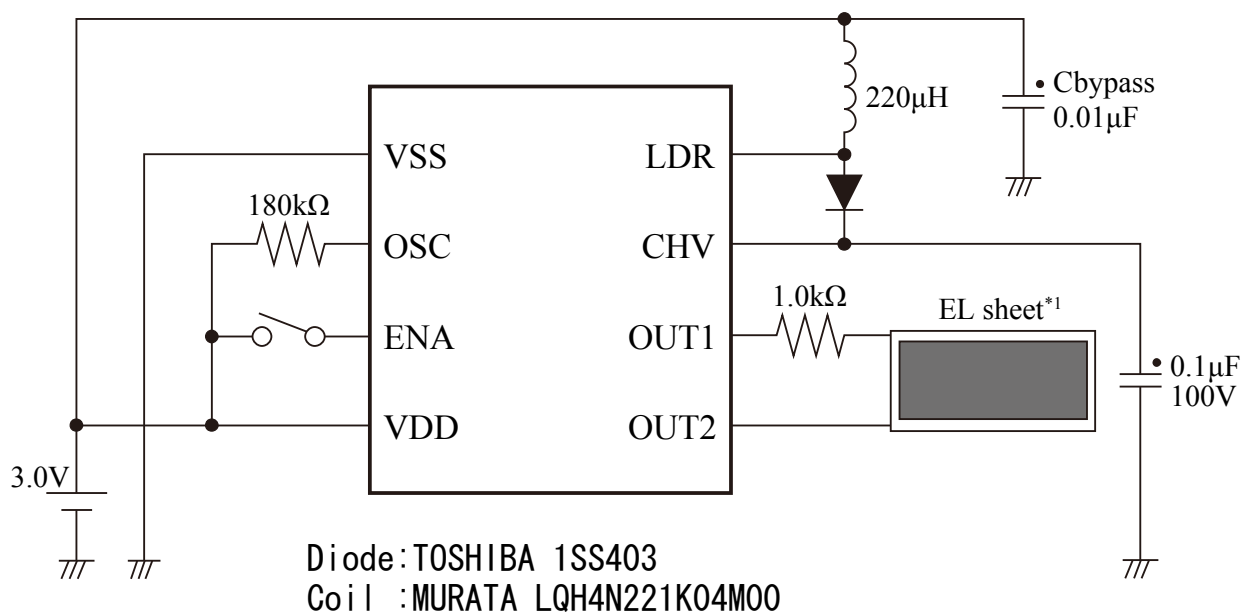

(3) EL sheet size : 10 to 15cm²
 Current consumption : 20mA

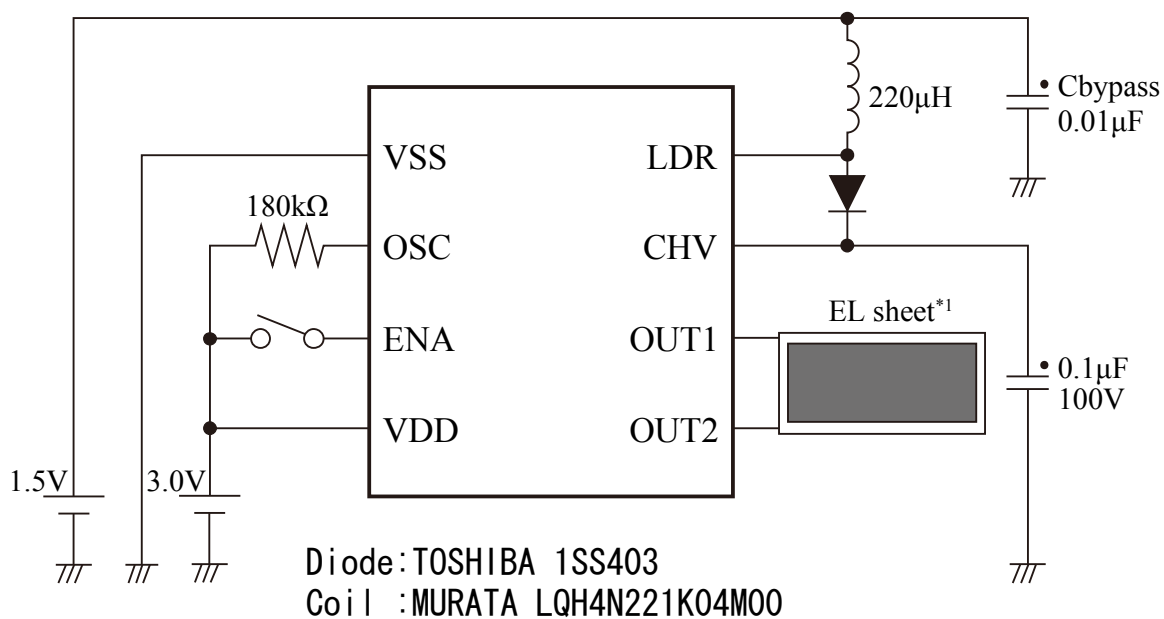

(4) EL sheet size : 10 to 20cm²
 Current consumption : 26mA

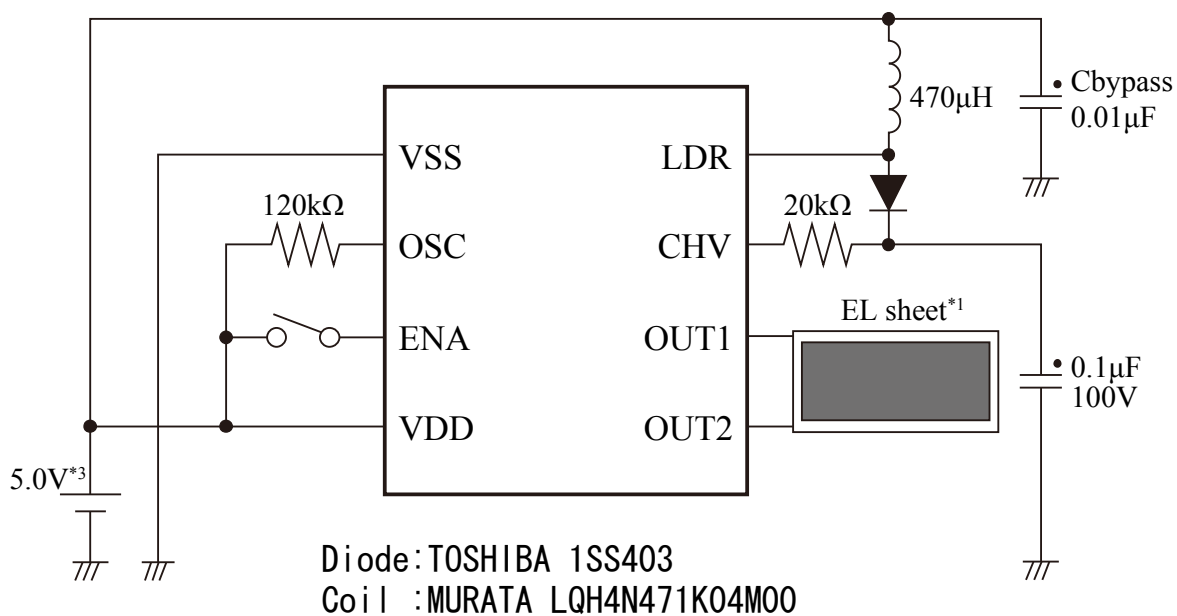

(5) EL sheet size : 30 to 50 cm²*2
 Current consumption : 34mA

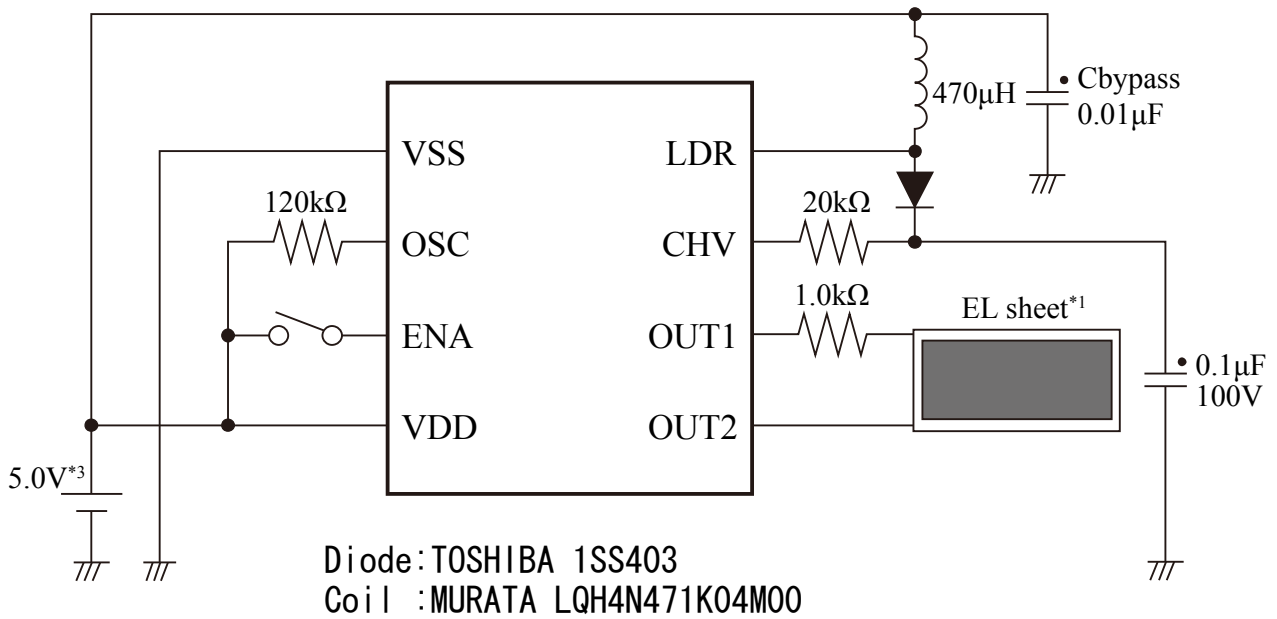

- *1. Do not operate the IC with the EL sheet NOT connected (no load to OUT1/OUT2) since the IC will be damaged.
- *2. If the EL sheet size is exceeded 30cm², connect a 1.0kΩ resistor between the EL sheet and the OUT1 pin.
- *3. When the supply voltage is exceeded 4.0V, connect a 20kΩ resistor to CHV for current limit, and the OUT1 pin resistor is set 1.0kΩ (EL sheet size>30cm²) or 1.0kΩ or less (EL sheet size≤30cm²).

Please pay your attention to the following points at time of using the products shown in this document.

1. The products shown in this document (hereinafter "Products") are designed and manufactured to the generally accepted standards of reliability as expected for use in general electronic and electrical equipment, such as personal equipment, machine tools and measurement equipment. The Products are not designed and manufactured to be used in any other special equipment requiring extremely high level of reliability and safety, such as aerospace equipment, nuclear power control equipment, medical equipment, transportation equipment, disaster prevention equipment, security equipment. The Products are not designed and manufactured to be used for the apparatus that exerts harmful influence on the human lives due to the defects, failure or malfunction of the Products. If you wish to use the Products in that apparatus, please contact our sales section in advance.
In the event that the Products are used in such apparatus without our prior approval, we assume no responsibility whatsoever for any damages resulting from the use of that apparatus.
2. NPC reserves the right to change the specifications of the Products in order to improve the characteristics or reliability thereof.
3. The information described in this document is presented only as a guide for using the Products. No responsibility is assumed by us for any infringements of patents or other rights of the third parties which may result from its use. No license is granted by implication or otherwise under any patents or other rights of the third parties. Then, we assume no responsibility whatsoever for any damages resulting from that infringements.
4. The constant of each circuit shown in this document is described as an example, and it is not guaranteed about its value of the mass production products.
5. In the case of that the Products in this document falls under the foreign exchange and foreign trade control law or other applicable laws and regulations, approval of the export to be based on those laws and regulations are necessary. Customers are requested appropriately take steps to obtain required permissions or approvals from appropriate government agencies.



SEIKO NPC CORPORATION

1-9-9, Hatchobori, Chuo-ku,
Tokyo 104-0032, Japan
Telephone: +81-3-5541-6501
Facsimile: +81-3-5541-6510
<http://www.npc.co.jp/>
Email:sales@npc.co.jp

ND11013-E-00 2011.10