

BLOCK DIAGRAM

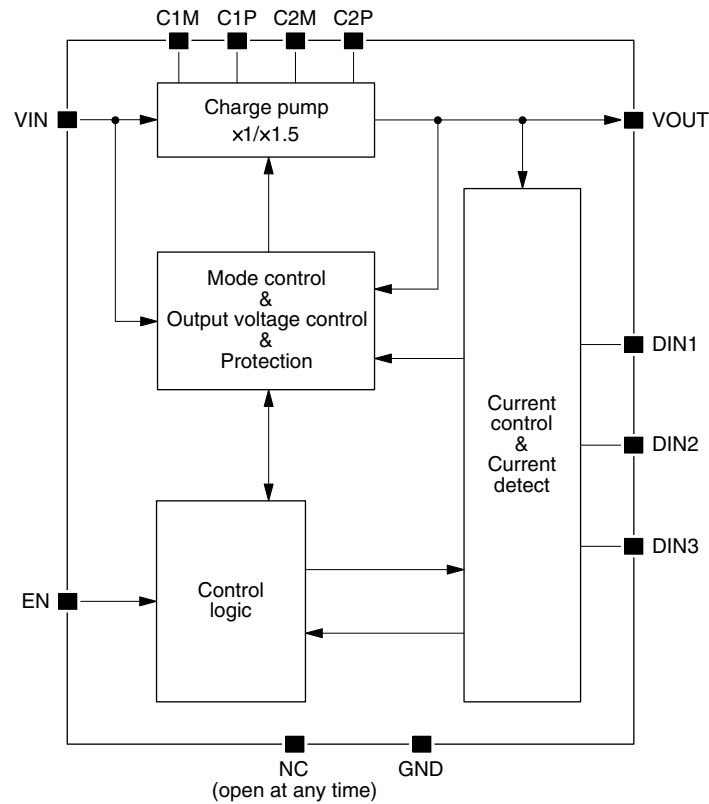

PIN DESCRIPTION

Number	Name	I/O	Description
1	C1M	-	Charge pump boost capacitor connection 1M
2	C2M	-	Charge pump boost capacitor connection 2M
3	C2P	-	Charge pump boost capacitor connection 2P
4	C1P	-	Charge pump boost capacitor connection 1P
5	VOUT	O	LED drive voltage output
6	EN	I	Enable/LED drive current setting (High active)
7	DIN3	O	LED drive current control output 3 (connect to ground when not used)
8	DIN2	O	LED drive current control output 2 (connect to ground when not used)
9	DIN1	O	LED drive current control output 1 (connect to ground when not used)
10	NC	-	No connection
11	PGND	-	Ground
12	VIN	-	Supply voltage input

SPECIFICATIONS

Absolute Maximum Ratings

GND = 0V

Parameter	Symbol	Rating	Unit
VIN voltage range	V_{IN}	-0.3 to 6.0	V
Input voltage range	V_{EN}	-0.3 to $V_{IN} + 0.3$	V
Output voltage range	$V_{DIN1 \text{ to } 3}$	-0.3 to $V_{IN} + 0.3$	V
	V_{OUT}	6.0	V
VOUT output current	I_{OUT}	500	mA
Power dissipation	P_D	800 ($T_a = 25^\circ\text{C}$)*1	mW
Junction temperature	T_{JMAX}	+125	$^\circ\text{C}$
Storage ambient temperature range	T_{stg}	-55 to +125	$^\circ\text{C}$

*1. When mounted on a 4-layer board.

Note. The device may suffer breakdown if any one of these parameter ratings is exceeded.

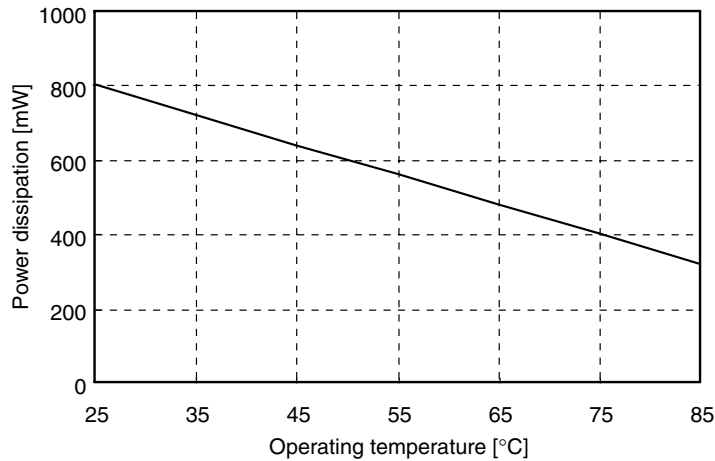

Package power dissipation when mounted on 4-layer board

Recommended Operating Conditions

GND = 0V

Parameter	Pin	Symbol	Conditions	Rating			Unit
				min	typ	max	
Supply voltage range	VIN	V_{IN0}	$I_{OUT} = 0\text{mA}$	2.7	3.6	4.6	V
		V_{IN}	$I_{OUT} = 60\text{mA}$	3.3	3.6	4.6	V
Input voltage range	EN	V_{ES}	Logic-level inputs	0	—	V_{IN}	V
Ambient temperature range	—	T_a		-40	—	+85	$^\circ\text{C}$

Electrical Characteristics

$V_{IN} = 3.6V$, $GND = 0V$, $T_a = 25^\circ C$ unless otherwise noted.

Parameter	Pin	Symbol	Condition	Rating			Unit
				min	typ	max	
Standby current	VIN	I_{STB}	Standby mode	–	0.01	1.00	μA
Quiescent current 1	VIN	I_{DD1}	$\times 1.0$ mode, $I_{OUT} = 0mA$	–	0.3	1.0	mA
Quiescent current 2		I_{DD2}	$\times 1.5$ mode, $I_{OUT} = 0mA$	–	1.0	2.0	mA
Output voltage	VOUT	V_{OUT}	$\times 1.5$ mode, $V_{IN} = 3.6V$, $I_{OUT} = 0mA$	4.5	5.0	5.5	V
			$\times 1.5$ mode, $V_{IN} = 3.0V$, $I_{OUT} = 60mA$	–	3.5	–	V
Maximum output current	VOUT	I_{OUT}	$\times 1.5$ mode	60	–	–	mA
Operating frequency	C1M	f_{OSC}	$\times 1.5$ mode switching frequency	800	1000	1200	kHz
Internal power-ON reset time ^{*1}	EN	T_{POR}	Rest time from when power is applied	–	0.05	1.00	ms
Power-ON rise time	EN, VIN	T_{PR}	EN = VIN, time from 0.3V to 2.7V	–	–	50	μs
Soft start time	DIN1 to 3	T_{SS}	EN startup \rightarrow I_{LED} rising edge	–	2.00	3.00	ms
LED drive pin leakage current	DIN1 to 3	$I_{Leak1\ to\ 3}$	Standby mode, DIN pin = 5.0V	–	0.01	1.00	μA
LED drive current	DIN1 to 3	$I_{LED1\ to\ 3}$	$\times 1.0$ mode (3-channel average value)	18.0	20.0	22.0	mA
LED drive current accuracy	DIN1 to 3	ΔI_{LED}	$\times 1.0$ mode, relative accuracy between channels at I_{LED} maximum settings	–5.0	–	+5.0	%
LED drive pin voltage	DIN1 to 3	$V_{DIN1\ to\ 3}$	$\times 1.0$ mode, $I_{LED} = 20mA$	–	120	–	mV
$\times 1.0 \leftrightarrow \times 1.5$ mode switching threshold voltage	VIN	$V_{TH1.0\ to\ 1.5}$	VF (LED) = 3.3V, $I_{LED} = 20mA$	–	3.46	–	V
EN hold time ^{*1*2}	EN	T_{CEH}	Time from when EN = LOW until shutdown	0.50	1.00	1.50	ms
EN HIGH-level input time ^{*1}	EN	T_{ENH}	EN input pulse HIGH-level minimum pulsewidth	4.0	–	–	μs
EN LOW-level input time ^{*1*2}	EN	T_{ENL}	EN input pulse LOW-level pulsewidth range	4.0	–	500	μs
Logic input voltage	EN	V_{IH}	HIGH-level input voltage range	1.4	–	–	V
		V_{IL}	LOW-level input voltage range	–	–	0.3	V
Logic input current	EN	I_{IH}	Pull-down pin, EN pin = 3.6V	–	5.0	10.0	μA
		I_{IL}	EN pin = 0V	–1.0	–	–	μA

*1. Design guaranteed value

*2.

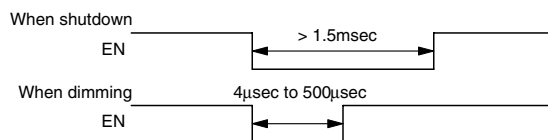

FUNCTIONAL DESCRIPTION

LED Drive Current Setting

The SM8136A LED drive current can be set using the EN pin. The EN input is used to enable/disable circuit operation. It also is used by a built-in counter that counts the number of input pulses in order to set the LED current value. The built-in counter is a 4-bit counter for 16-step adjustment (DATA = 1 to 16). On the 16th pulse (DATA = 16), the LED current drive circuit shuts down and LED current is zero. On the 17th pulse (DATA = 1), the current returns to the maximum value. As the initial pulse (DATA = 1) sets the current to the maximum value, the device can also be used in applications that do not support pulsed input.

Table 1. EN input pulse count and LED current setting values

DATA	1	2	3	4	5	6	7	8	9	10	11	12	13	14	15	16
EN pulse count	1	2	3	4	5	6	7	8	9	10	11	12	13	14	15	16
I_{LED} [mA]	20.00	18.7	17.3	16.0	14.7	13.3	12.0	10.7	9.3	8.0	6.7	5.3	4.0	2.7	1.3	0

EN Input Signal and LED Current Setting (Initialization)

On the first rising edge of EN, the internal startup signal goes HIGH and LED current will start to flow after the soft start time has elapsed. As the LED current setting is adjusted by counting the number of input pulses on EN, the EN input voltage must be switched HIGH → LOW → HIGH repeatedly to set the current to a lower value. After the desired value is achieved, the EN input voltage is held HIGH to maintain the LED current setting. If the EN input goes LOW, the LED current does not flow. The EN data input circuit operates even though the LED current does not flow during the soft start interval, but as long as the current value is set during the soft start interval the LED drive circuits will start to drive the LEDs with that constant current setting. However, note that the setting is valid only after the power-ON reset when the VIN supply is applied. Accordingly, allow 1ms or more after connecting the VIN supply before setting the current value using the EN input.

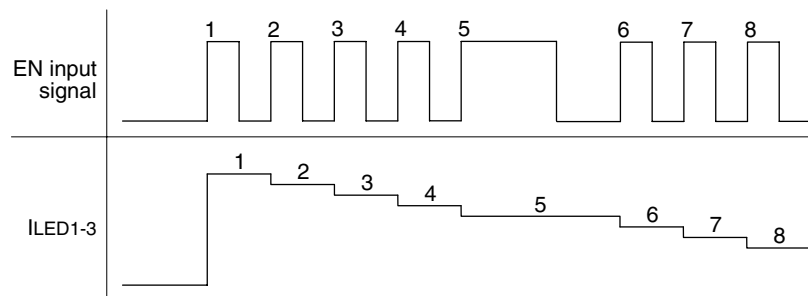

EN input signal and LED current setting

- LED current setting is determined by the number of EN input signal rising edges. Furthermore, no LED current flows until the soft start time has elapsed.

V_{OUT} Output Circuit Mode Switching

The SM8136A output mode switches between 3 operating modes in response to the operating conditions. The modes are: standby mode, $\times 1.0$ mode (VIN through mode), and $\times 1.5$ mode (1.5-times charge pump boost). The V_{OUT} output switches automatically between these modes in response to the drive LED characteristics and the overall power consumption. Switching from $\times 1.0$ mode to $\times 1.5$ mode is controlled automatically by an internal circuit. The operating mode cannot be specified by an external control signal.

Startup: Internal Reset Time and Soft Start Time

The SM8136A normal startup procedure (after V_{IN} has been applied previously) is to switch from standby mode to the $\times 1.0/\times 1.5$ operating modes when the EN enable input goes HIGH. The soft start time (described on the following page) begins after switching to the operating mode using EN.

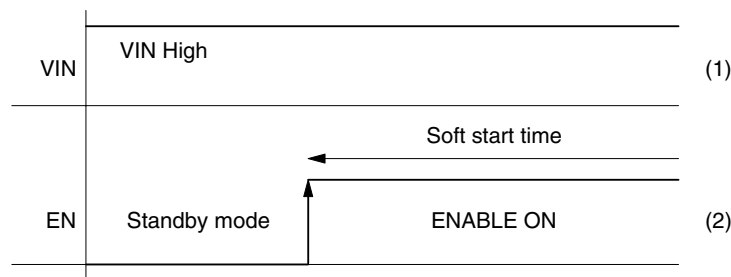

Normal startup

(1) VIN is HIGH, EN is LOW (standby mode)

(2) Switches to an operating mode when EN goes HIGH (soft start time begins)

If the use at EN = VIN when power is applied, the startup commences after the power-ON reset (POR) time (approximately 50 μ s) has elapsed.

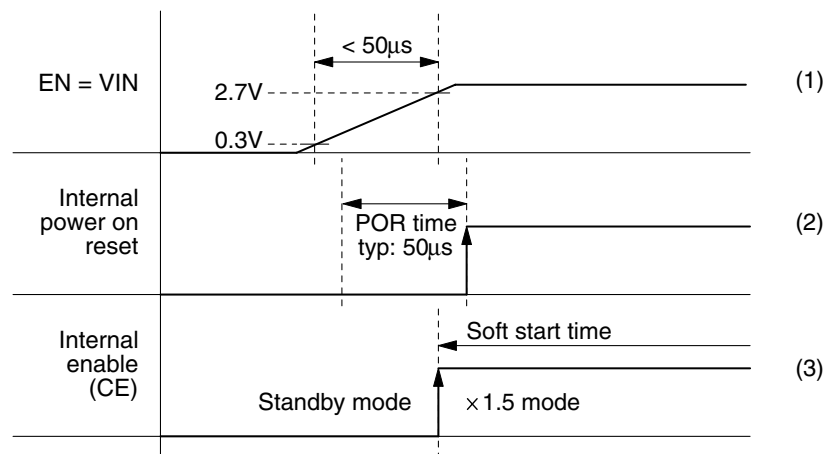

Internal reset operation when power is applied (power-ON reset)

(1) When using at EN = VIN, rising time from 0.3V to 2.7V should set <math>< 50\mu\text{s}</math>.

(2) Power-ON reset (POR) circuit resets internal circuits approximately 50 μ s after the power is applied.

(3) If EN is HIGH when power is applied, the internal circuits start operating when the internal "CE" signal rising edge occurs after the power-ON reset time. If EN is LOW when power is applied, the "CE" rising edge occurs simultaneously with the first rising edge.

Immediately after startup, the device operates in $\times 1.5$ mode for a fixed interval (soft start time: approximately 2ms) to set the current for LEDs connected to the DIN pins.

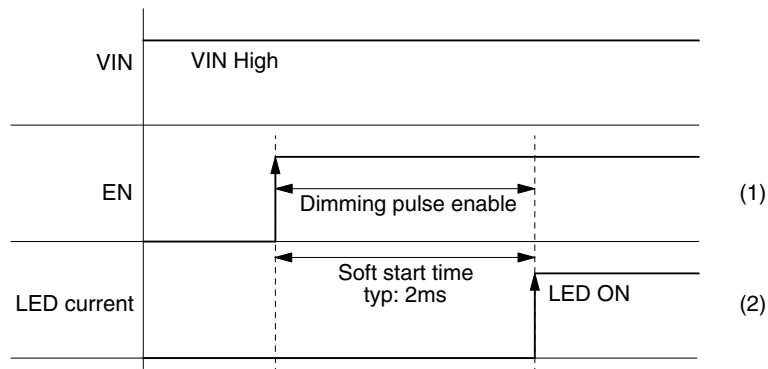

Soft start time and LED current

- (1) If the EN signal is input after power is applied, the soft start time begins on the EN rising edge. The EN input signal for dimming is active during the soft start time.
- (2) The LED drive starts immediately before the end of the LED turn-on delay time.

Switching to Standby Mode

The SM8136A operating mode switches from $\times 1.0/\times 1.5$ mode to standby mode if EN goes LOW and stays LOW for an interval of 1.00ms (typ). This function is used to switch the internal circuits to standby mode automatically when the LEDs turn OFF in order to reduce current consumption.

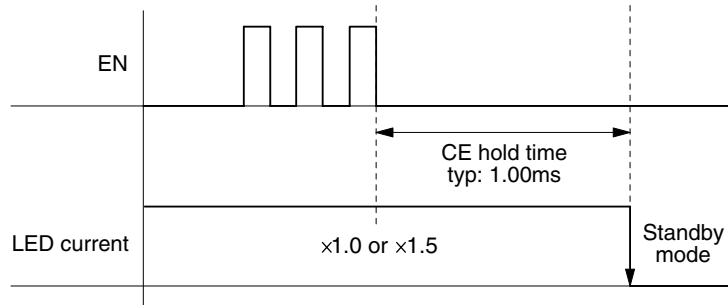

Switching to standby mode, and EN hold time

- When EN is LOW for longer than the CE hold time of 1.00ms (typ), the SM8136A switches to standby mode. In standby mode, the internal circuits are reset, hence the drive current settings must be re-entered to restart the device.

Switching from $\times 1.0$ Mode to $\times 1.5$ Mode

When the LEDs are ON and can be driven at the fixed current value set by the EN pulse input without needing to boost the VIN input voltage, the VOUT output operates in $\times 1.0$ mode. In other words, if sufficient current flows to counter the LED forward-bias voltage drop VF, it means the VOUT voltage may drop below 5.0V. The longer that the driver output operates in the more efficient $\times 1.0$ mode, the lower the total power consumption and the longer the battery life can be extended. Also, by using LEDs with low VF and a lower LED drive current setting, the longer the device can operate automatically in $\times 1.0$ mode.

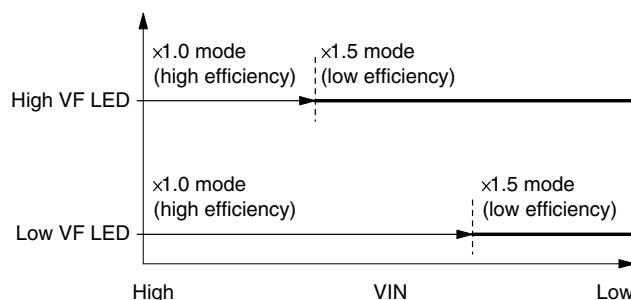

V_{OUT} mode switching interval comparison due to drive LED “VF” variation

If the VIN voltage drops and the LED current drops below the fixed current setting in $\times 1.0$ mode, an undercurrent detection circuit connected to each LED drive circuit activates and automatically switches the VOUT output mode to $\times 1.5$ mode that uses a charge pump to boost the voltage by a factor of 1.5. The LED undercurrent detection circuit switches the output mode when it detects an undercurrent condition on any one of the three channels. Accordingly, there should be as low a variation as possible in drive LED VF values in order to improve overall efficiency.

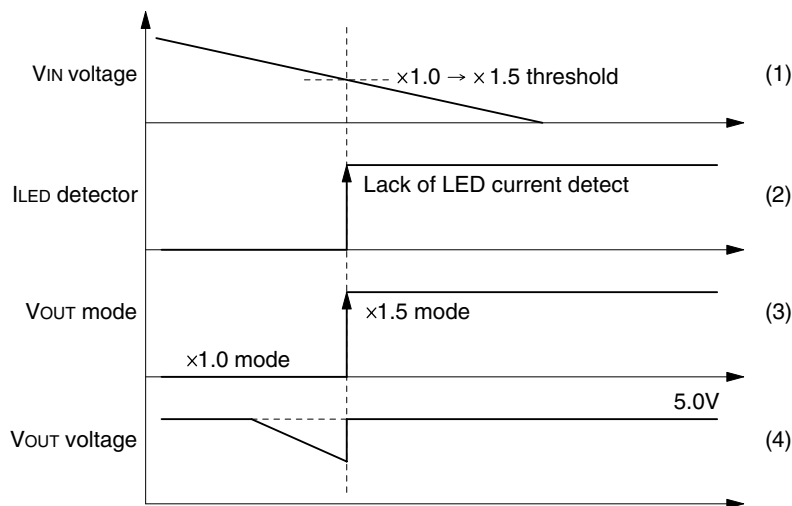

V_{IN} voltage drop and V_{OUT} output voltage

- (1) The VIN voltage drops below the $\times 1.5$ mode threshold value.
- (2) When the voltage drops below the $\times 1.5$ mode threshold, the I_{LED} detection circuit raises an I_{LED} undercurrent signal.
- (3) The VOUT output switches to $\times 1.5$ mode in response to the I_{LED} undercurrent signal.
- (4) The VOUT voltage drops below 5.0V but still supplies sufficient current until reaching the $\times 1.5$ switching threshold.

Note that if the LEDs connected to the DIN pins are switched after startup, the LED connection detection circuit will operate incorrectly and the correct mode switching functions cannot occur.

Switching from $\times 1.5$ Mode to $\times 1.0$ Mode

The LED VF increases immediately after the LED current starts to flow, and then decreases as the LED temperature increases due to the heating effect of the current flow. It can take about 10 seconds or more for the LED temperature to stabilize and for VF to reach equilibrium, and VF may fluctuate more than 200mV. The VF fluctuation is affected by the ambient temperature and LED current setting, and has a large effect on the automatic mode switching voltage tolerances. To counter the effects of VF fluctuation, the SM8136A outputs a mode reset signal once every 1.0 seconds which automatically switches the output mode to $\times 1.0$, and then a determination is made whether to make the $\times 1.0 \rightarrow \times 1.5$ mode switch.

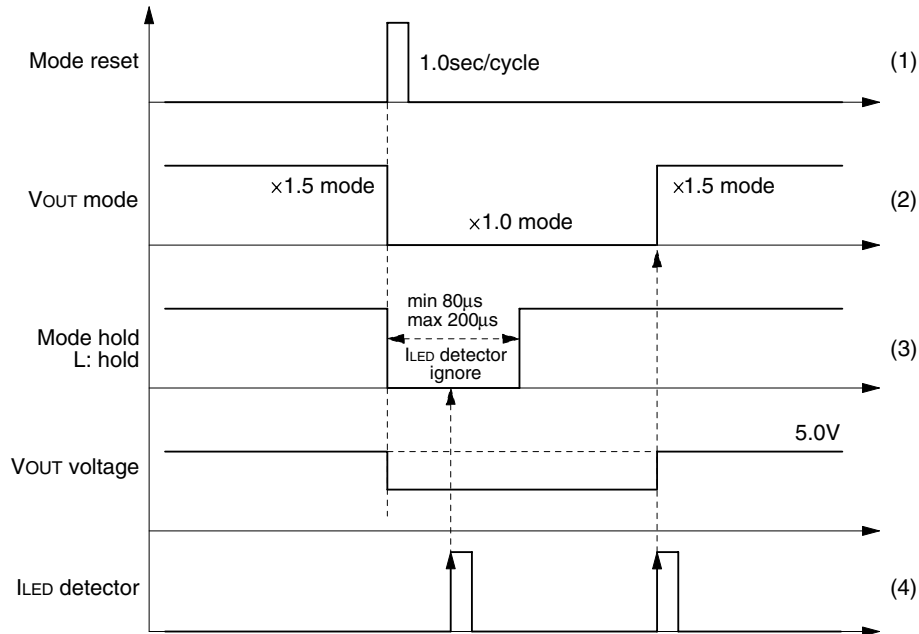

Switching from $\times 1.5$ mode to $\times 1.0$ mode due to mode reset signal

- (1) Mode reset signal is output once every 1.0 seconds.
- (2) Mode switches from $\times 1.5$ to $\times 1.0$ mode on the rising edge of the mode reset signal.
- (3) A 200 μ s (max) mode hold time begins after switching to $\times 1.0$ mode. LED drive current insufficient state is detected but the mode is not switched during this interval.
- (4) LED drive current insufficient signal is ignored during the mode hold time, but normal mode switching operation resumes when the mode hold time elapses.

A mode hold signal of 200 μ s (max) duration is output immediately after switching to $\times 1.0$ mode. The V_{OUT} output is held in $\times 1.0$ mode and any LED drive current insufficient detection signal is ignored during the mode hold signal output. For example, if the V_{IN} voltage drops and the V_{OUT} output voltage in $\times 1.0$ mode cannot provide sufficient current to drive the LEDs, a LED drive current insufficient condition occurs momentarily due to the mode reset. The LED low-current detector circuit outputs a LED drive current insufficient signal immediately after switching modes, but during the mode hold time the device stays in $\times 1.0$ mode and does not switch to $\times 1.5$ mode. Consequently, the V_{OUT} voltage drops and the LED brightness decreases during the 85 μ s (min) to 200 μ s (max) mode hold time. However, a 200 μ s decrease in the brightness is not a problem as it is not perceptible to the human eye.

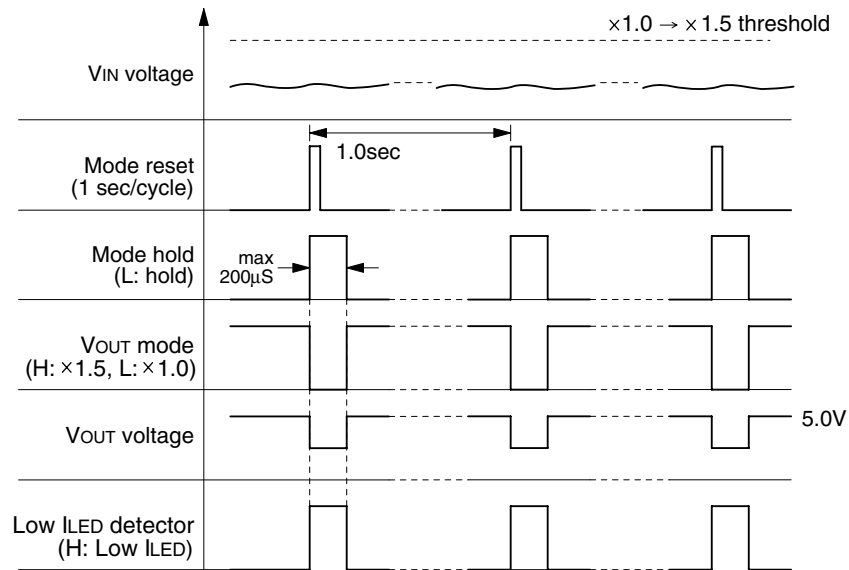

V_{OUT} drop due to mode reset signal

PERIPHERAL PARTS

About the External Capacitors

The best capacitors for use with the SM8136A are multi-layer ceramic capacitors. When selecting a multi-layer ceramic capacitor, only X5R and X7R dielectric types are strongly recommended, since the loss of capacitance in various conditions is less than other types such as Z5U and Y5V. The much loss of capacitance in various conditions may cause the output voltage unstable.

The EIA three digit "TC" code

Lower temperature limit	High temperature limit	Maximum allowable capacitance change from +25°C (0V DC)
X = -55°C	5 = +85°C	F = ± 7.5%
Y = -30°C	6 = +105°C	P = ± 10%
Z = +10°C	7 = +125°C	R = ± 15%
	8 = +150°C	S = ± 22%
		T = +22%/-33%
		U = +22%/-56%
		V = +22%/-82%

For example : X5R

Recommended parts list

Manufacture	Part number	Capacitance [μ F]	Dimensions [mm]		
			W	L	T
TDK	C1608JB1C105K	1.0	1.6	0.8	0.8
MURATA	GRM188B11A105KA61	1.0	1.6	0.8	0.8

About the Input Capacitor "C4"

The parts layout of PCB may merely cause the “ V_{OUT} ” output voltage unstable. In this case, increasing the “C4” input capacitance value or adding another capacitor on the VIN input line is effective to solve the unstable output voltage.

TYPICAL APPLICATION CIRCUITS

LED × 3

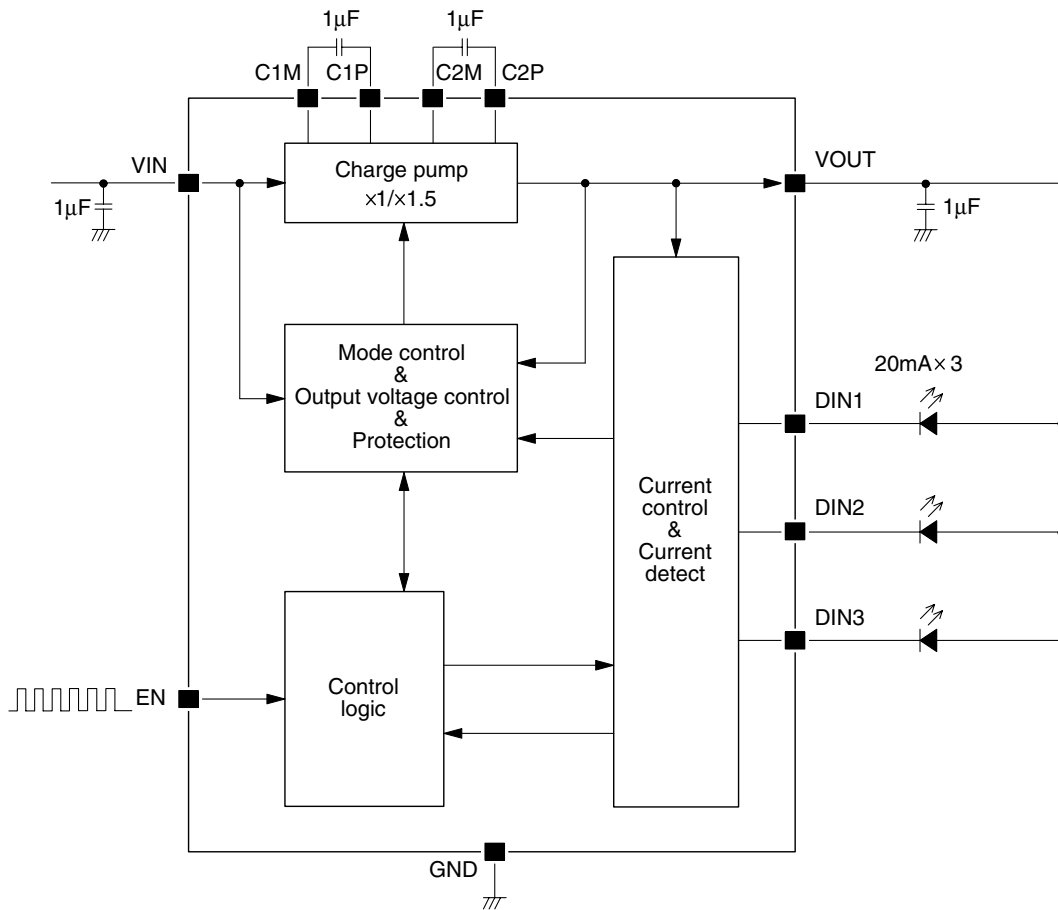

Note. If the driving LED is less than 3 pcs, unused DIN pins should be connect to GND.

The HIGH-level and LOW-level pulsewidths for the pulse input on EN must be 4.0µs or longer (see "Electrical Characteristics").

FOOTPRINT PATTERN

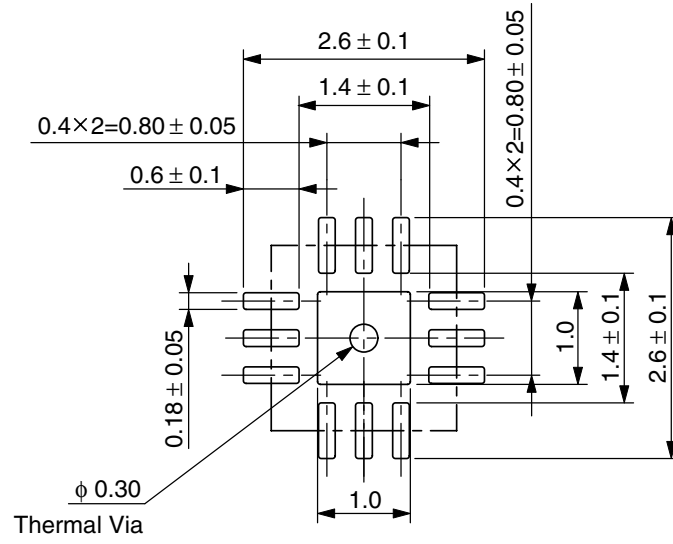

Please pay your attention to the following points at time of using the products shown in this document.

The products shown in this document (hereinafter "Products") are not intended to be used for the apparatus that exerts harmful influence on human lives due to the defects, failure or malfunction of the Products. Customers are requested to obtain prior written agreement for such use from SEIKO NPC CORPORATION (hereinafter "NPC"). Customers shall be solely responsible for, and indemnify and hold NPC free and harmless from, any and all claims, damages, losses, expenses or lawsuits, due to such use without such agreement. NPC reserves the right to change the specifications of the Products in order to improve the characteristic or reliability thereof. NPC makes no claim or warranty that the contents described in this document dose not infringe any intellectual property right or other similar right owned by third parties. Therefore, NPC shall not be responsible for such problems, even if the use is in accordance with the descriptions provided in this document. Any descriptions including applications, circuits, and the parameters of the Products in this document are for reference to use the Products, and shall not be guaranteed free from defect, inapplicability to the design for the mass-production products without further testing or modification. Customers are requested not to export or re-export, directly or indirectly, the Products to any country or any entity not in compliance with or in violation of the national export administration laws, treaties, orders and regulations. Customers are requested appropriately take steps to obtain required permissions or approvals from appropriate government agencies.

The logo for NPC (Seiko NPC Corporation) consists of the letters 'NPC' in a bold, black, sans-serif font. The 'N' and 'P' are connected at the top, and the 'C' is positioned to the right of the 'P'.

SEIKO NPC CORPORATION

1-9-9, Hatchobori, Chuo-ku,
Tokyo 104-0032, Japan
Telephone: +81-3-5541-6501
Facsimile: +81-3-5541-6510
<http://www.npc.co.jp/>
Email: sales@npc.co.jp

NC0717AE 2008.12