

OVERVIEW

The SM5024 series are fundamental crystal oscillator module ICs. They feature an oscillator circuit with built-in capacitors with excellent frequency response and an output buffer with high output drive capability. They are available in miniature 6-pin packages, making them ideal as DIP-type crystal oscillators.

FEATURES

- Operating supply voltage range
 - 3V operation: 2.7 to 3.6V
 - 5V operation: 4.5 to 5.5V
- Up to 30MHz operating frequency range (fundamental oscillation)
- -40 to 85°C operating temperature range
- Oscillator capacitors C_G , C_D built-in
- Feedback resistor R_f built-in
- f_O , $f_O/2$, $f_O/4$, $f_O/8$ output frequency, determined by internal connection
- Output drive capability
 - 8mA ($V_{DD} = 2.7V$)
 - 16mA ($V_{DD} = 4.5V$)
- Output three-state function built-in
High impedance outputs in standby mode
- CMOS output duty level (1/2VDD)
- Molybdenum-gate CMOS process
- Package: SOT23-6 (SM5024×××H)

PACKAGE DIMENSIONS

(Unit: mm)

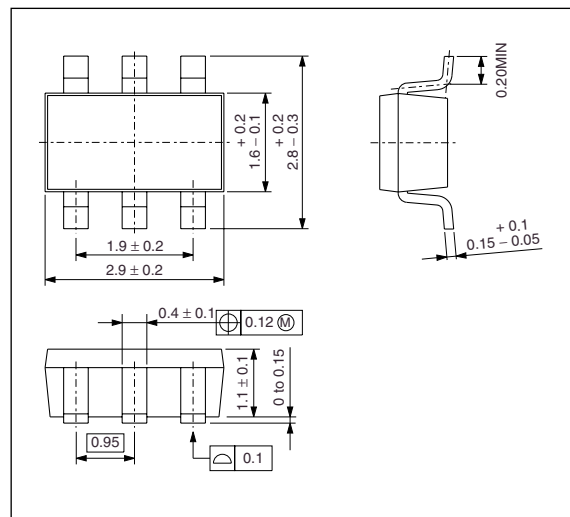

APPLICATIONS

- DIP-type crystal oscillator modules

SERIES CONFIGURATION

Version	Operating Supply voltage range [V]	Recommended operating frequency range ¹ [MHz]	Built-in capacitance [pF]		Output duty level	Output frequency	INHN input level	Standby mode	
			C_G	C_D				Oscillator stop function	Output state
SM5024AL1H	2.7 to 5.5	4 to 30	8	10	CMOS	f_O	TTL	Yes	Hi-Z
SM5024AL2H						$f_O/2$			
SM5024AL3H						$f_O/4$			
SM5024AL4H						$f_O/8$			

1. The recommended operating frequency is a yardstick value derived from the crystal used for NPC characteristics authentication. However, the oscillator frequency band is not guaranteed. Specifically, the characteristics can vary greatly due to crystal characteristics and mounting conditions, so the oscillation characteristics of components must be carefully evaluated.

ORDERING INFORMATION

Device	Package
SM5024×××H	SOT23-6

PINOUT

(Top view)

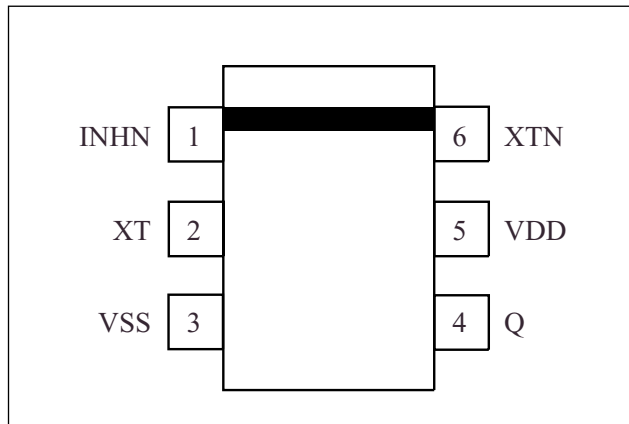

PIN DESCRIPTION

Name	I/O	Description	
INHN	I	Output state control input. High impedance when LOW. Pull-up resistor built-in.	
XT	I	Amplifier input	Crystal connection pins. Crystal is connected between XT and XTN.
XTN	O	Amplifier output	
VSS	-	Ground	
Q	O	Output. Output frequency (f_O , $f_O/2$, $f_O/4$, $f_O/8$) determined by internal connection	
VDD	-	Supply voltage	

BLOCK DIAGRAM

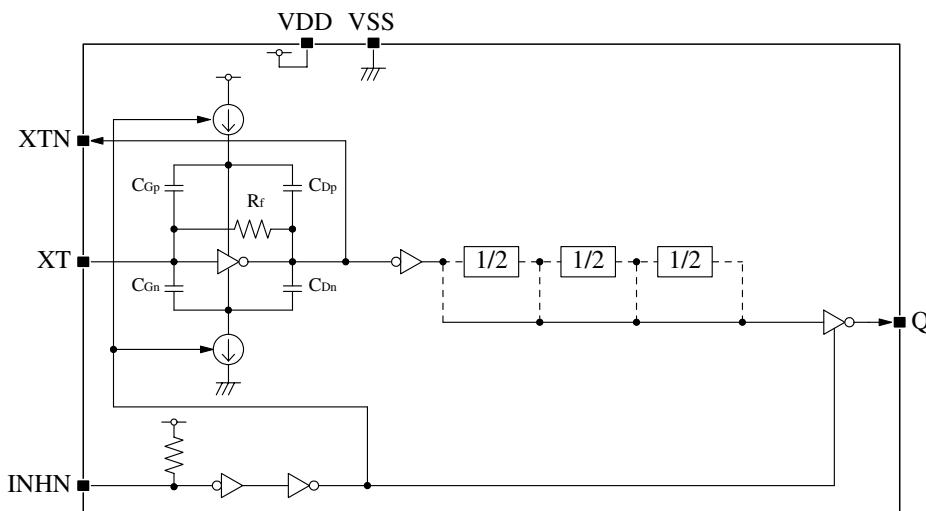

INHN = LOW active

Notes. The SM5024 series reduce crystal current by limiting driving current of oscillating-stage inverter and inhibiting oscillating amplitude. Depending on the characteristics of using crystal or the mounting condition, they may not oscillate normally. Please evaluate the oscillation start-up characteristics adequately with your actual device. When this device is used for buffer application, please pay attention to input amplitude to the XT pin. If it's low input amplitude, the SM5024 series may not operate normally.

FUNCTIONAL DESCRIPTION

Standby Function

When INHN goes LOW, the oscillator stops and the oscillator output on Q becomes high impedance.

INHN	Q	Oscillator
HIGH (or open)	Any f_0 , $f_0/2$, $f_0/4$, or $f_0/8$ output frequency	Normal operation
LOW	High impedance	Stopped

Current consumption and Output waveform with NPC's standard crystal

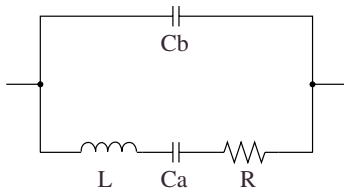

f [MHz]	R [Ω]	L [mH]	Ca [fF]	Cb [pF]
30	5.26	2.82	1.00	2.68

SPECIFICATIONS

Absolute Maximum Ratings

$V_{SS} = 0V$

Parameter	Symbol	Condition	Rating	Unit
Supply voltage range	V_{DD}		-0.5 to +7.0	V
Input voltage range	V_{IN}		-0.5 to $V_{DD} + 0.5$	V
Output voltage range	V_{OUT}		-0.5 to $V_{DD} + 0.5$	V
Operating temperature range	T_{opr}		-40 to +85	°C
Storage temperature range	T_{STG}		-55 to +125	°C
Output current	I_{OUT}		20	mA
Power dissipation	P_D		250	mW

Recommended Operating Conditions

3V operation

$V_{SS} = 0V$, $f \leq 30MHz$, $C_L \leq 15pF$ unless otherwise noted.

Parameter	Symbol	Condition	Rating			Unit
Operating supply voltage	V_{DD}		2.7	-	3.6	V
Input voltage	V_{IN}		V_{SS}	-	V_{DD}	V
Operating temperature	T_{OPR}		-20	-	+80	°C

5V operation

$V_{SS} = 0V$, $f \leq 30MHz$, $C_L \leq 50pF$ unless otherwise noted

Parameter	Symbol	Condition	Rating			Unit
Operating supply voltage	V_{DD}		4.5	-	5.5	V
Input voltage	V_{IN}		V_{SS}	-	V_{DD}	V
Operating temperature	T_{OPR}		-40	-	+85	°C

Electrical Characteristics

3V operation

$V_{SS} = 0V$, recommended operating conditions unless otherwise noted.

Parameter	Symbol	Condition	Rating			Unit	
			min	typ	max		
HIGH-level output voltage	V_{OH}	Q: Measurement cct 1, $V_{DD} = 2.7V$, $I_{OH} = 8mA$	2.1	2.4	–	V	
LOW-level output voltage	V_{OL}	Q: Measurement cct 2, $V_{DD} = 2.7V$, $I_{OL} = 8mA$	–	0.3	0.5	V	
HIGH-level input voltage	V_{IH}	INH N	2.0	–	–	V	
LOW-level input voltage	V_{IL}	INH N	–	–	0.5	V	
Output leakage current	I_Z	Q: Measurement cct 2, INHN = LOW, $V_{DD} = 3.6V$	$V_{OH} = V_{DD}$	–	–	10	μA
			$V_{OL} = V_{SS}$	–	–	10	μA
Current consumption	I_{DD1}	Measurement cct 3, load cct 1, INH N = open, $C_L = 15pF$, $f = 30MHz$	SM5024AL1H	–	4	8	mA
			SM5024AL2H	–	2.5	5	mA
			SM5024AL3H	–	2	4	mA
			SM5024AL4H	–	1.5	3	mA
INH N pull-up resistance	R_{UP}	Measurement cct 4	25	100	250	$k\Omega$	
Feedback resistance	R_f	Measurement cct 5	200	600	1000	$k\Omega$	
Built-in capacitance	C_G	Design value. A monitor pattern on a wafer is tested.	7.44	8	8.56	pF	
	C_D		9.3	10	10.7	pF	

5V operation

$V_{SS} = 0V$, recommended operating conditions unless otherwise noted.

Parameter	Symbol	Condition	Rating			Unit	
			min	typ	max		
HIGH-level output voltage	V_{OH}	Q: Measurement cct 1, $V_{DD} = 4.5V$, $I_{OH} = 16mA$	3.9	4.2	–	V	
LOW-level output voltage	V_{OL}	Q: Measurement cct 2, $V_{DD} = 4.5V$, $I_{OL} = 16mA$	–	0.3	0.5	V	
HIGH-level input voltage	V_{IH}	INH N	2.0	–	–	V	
LOW-level input voltage	V_{IL}	INH N	–	–	0.8	V	
Output leakage current	I_Z	Q: Measurement cct 2, INHN = LOW, $V_{DD} = 5.5V$	$V_{OH} = V_{DD}$	–	–	10	μA
			$V_{OL} = V_{SS}$	–	–	10	μA
Current consumption	I_{DD2}	Measurement cct 3, load cct 1, INH N = open, $C_L = 50pF$, $f = 30MHz$	SM5024AL1H	–	13	26	mA
			SM5024AL2H	–	7	14	mA
			SM5024AL3H	–	4	8	mA
			SM5024AL4H	–	3	6	mA
INH N pull-up resistance	R_{UP}	Measurement cct 4	25	100	250	$k\Omega$	
Feedback resistance	R_f	Measurement cct 5	200	600	1000	$k\Omega$	
Built-in capacitance	C_G	Design value. A monitor pattern on a wafer is tested.	7.44	8	8.56	pF	
	C_D		9.3	10	10.7	pF	

Switching Characteristics

3V operation

$V_{DD} = 2.7$ to $3.6V$, $V_{SS} = 0V$, $T_a = -20$ to $+80^\circ C$ unless otherwise noted.

Parameter	Symbol	Condition	Rating			Unit
			min	typ	max	
Output rise time	t_{r1}	Measurement cct 6, load cct 1, $0.1V_{DD}$ to $0.9V_{DD}$, $C_L = 15pF$	–	5	10	ns
Output fall time	t_{f1}	Measurement cct 6, load cct 1, $0.9V_{DD}$ to $0.1V_{DD}$, $C_L = 15pF$	–	5	10	ns
Output duty cycle ¹	Duty1	Measurement cct 6, load cct 1, $V_{DD} = 3.0V$, $T_a = 25^\circ C$, $C_L = 15pF$, $f \leq 30MHz$	45	–	55	%
Output disable delay time ²	t_{PLZ}	Measurement cct 6, load cct 1, $V_{DD} = 3.0V$, $T_a = 25^\circ C$, $C_L = 15pF$	–	–	100	ns
Output enable delay time ²	t_{PZL}		–	–	100	ns

1. The duty cycle characteristic is checked the sample chips of each production lot.
2. Oscillator stop function is built-in. When INHN goes LOW, normal output stops. When INHN goes HIGH, normal output is not resumed until after the oscillator start-up time has elapsed.

5V operation

$V_{DD} = 4.5$ to $5.5V$, $V_{SS} = 0V$, $T_a = -40$ to $+85^\circ C$ unless otherwise noted.

Parameter	Symbol	Condition	Rating			Unit	
			min	typ	max		
Output rise time	t_{r1}	Measurement cct 6, load cct 1, $0.1V_{DD}$ to $0.9V_{DD}$	$C_L = 15pF$	–	2.5	5	ns
	t_{r2}		$C_L = 50pF$	–	5	10	
Output fall time	t_{f1}	Measurement cct 6, load cct 1, $0.9V_{DD}$ to $0.1V_{DD}$	$C_L = 15pF$	–	2.5	5	ns
	t_{f2}		$C_L = 50pF$	–	5	10	
Output duty cycle ¹	Duty2	Measurement cct 6, load cct 1, $V_{DD} = 5.0V$, $T_a = 25^\circ C$, $C_L = 50pF$, $f \leq 30MHz$	45	–	55	%	
Output disable delay time ²	t_{PLZ}	Measurement cct 6, load cct 1, $V_{DD} = 5.0V$, $T_a = 25^\circ C$, $C_L = 15pF$	–	–	100	ns	
Output enable delay time ²	t_{PZL}		–	–	100	ns	

1. The duty cycle characteristic is checked the sample chips of each production lot.
2. Oscillator stop function is built-in. When INHN goes LOW, normal output stops. When INHN goes HIGH, normal output is not resumed until after the oscillator start-up time has elapsed.

MEASUREMENT CIRCUITS

Measurement cct 1

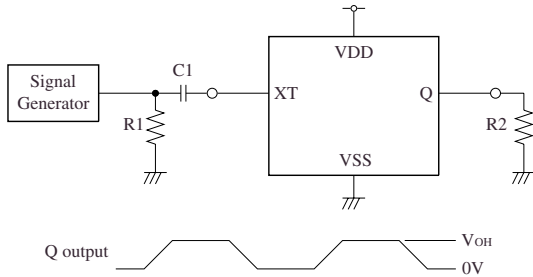

2.0Vp-p, 10MHz sine wave input signal (3V operation)
 3.5Vp-p, 10MHz sine wave input signal (5V operation)
 C1: 0.001μF
 R1: 50Ω
 R2: 263Ω (3V operation)
 244Ω (5V operation)

Measurement cct 2

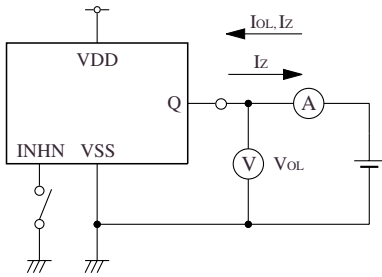

Measurement cct 3

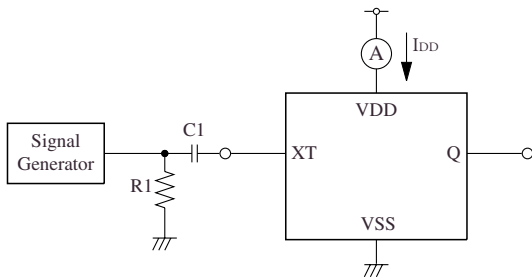

2.0Vp-p, 30MHz sine wave input signal (3V operation)
 3.5Vp-p, 30MHz sine wave input signal (5V operation)
 C1: 0.001μF
 R1: 50Ω

Measurement cct 4

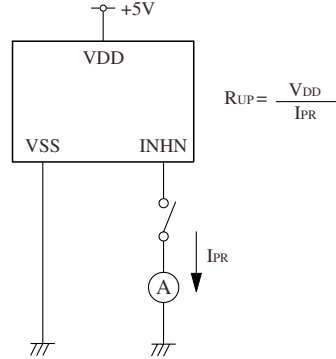

Measurement cct 5

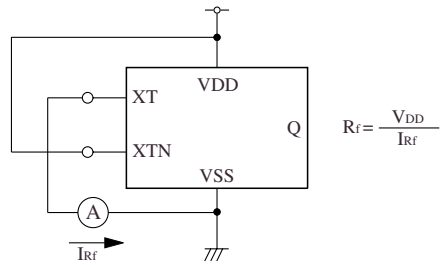

Measurement cct 6

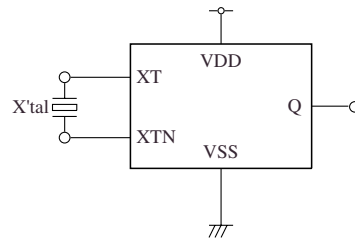

Measurement cct 7

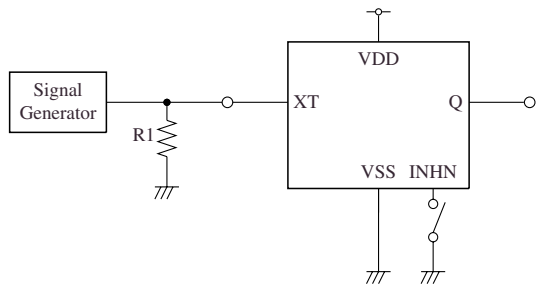

R1: 50Ω

Load cct 1

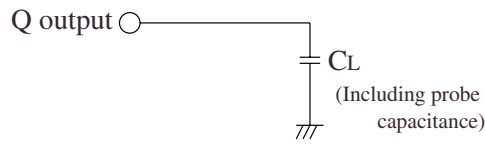

$C_L = 15\text{pF}: t_{r1}, t_{f1}, \text{Duty1}, I_{DD1}$
 $C_L = 50\text{pF}: t_{r2}, t_{f2}, \text{Duty2}, I_{DD2}$

Switching Time Measurement Waveform

Output duty level, t_r , t_f

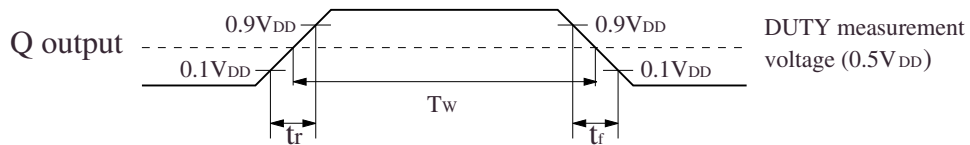

Output duty cycle

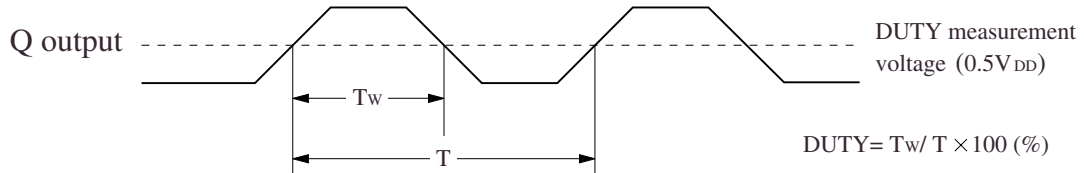

Output Enable/Disable Delay

When the device is in standby, the oscillator stops. When standby is released, the oscillator starts and stable oscillator output occurs after a short delay.

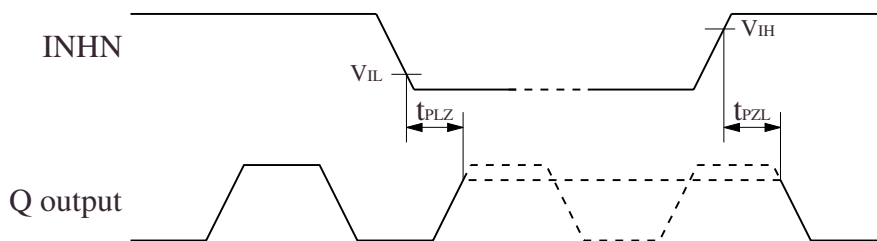

INHN input waveform $t_r = t_f \leq 10\text{ns}$

Please pay your attention to the following points at time of using the products shown in this document.

The products shown in this document (hereinafter "Products") are not intended to be used for the apparatus that exerts harmful influence on human lives due to the defects, failure or malfunction of the Products. Customers are requested to obtain prior written agreement for such use from SEIKO NPC CORPORATION (hereinafter "NPC"). Customers shall be solely responsible for, and indemnify and hold NPC free and harmless from, any and all claims, damages, losses, expenses or lawsuits, due to such use without such agreement. NPC reserves the right to change the specifications of the Products in order to improve the characteristic or reliability thereof. NPC makes no claim or warranty that the contents described in this document dose not infringe any intellectual property right or other similar right owned by third parties. Therefore, NPC shall not be responsible for such problems, even if the use is in accordance with the descriptions provided in this document. Any descriptions including applications, circuits, and the parameters of the Products in this document are for reference to use the Products, and shall not be guaranteed free from defect, inapplicability to the design for the mass-production products without further testing or modification. Customers are requested not to export or re-export, directly or indirectly, the Products to any country or any entity not in compliance with or in violation of the national export administration laws, treaties, orders and regulations. Customers are requested appropriately take steps to obtain required permissions or approvals from appropriate government agencies.

The logo for NPC (Seiko NPC Corporation) consists of the letters 'NPC' in a bold, black, sans-serif font. The 'N' and 'P' are connected at the top, and the 'C' is positioned to the right of the 'P'.

SEIKO NPC CORPORATION

1-9-9, Hatchobori, Chuo-ku,
Tokyo 104-0032, Japan
Telephone: +81-3-5541-6501
Facsimile: +81-3-5541-6510
<http://www.npc.co.jp/>
Email: sales@npc.co.jp

NC0303DE 2008.10