

OVERVIEW

The CF5760 series are analog clock ICs that derive their timing from a 32.768 kHz oscillator element. They feature a reset function (optional seconds control function) which can be used to maintain accurate time. Various alarm functions and motor outputs are available to match a wide range of clock specifications.

FEATURES

- 1.2 to 2.0V operating supply voltage
- 1.2μA (typ) / 1.5V current consumption
- 32.768 kHz oscillator circuit
- Oscillator capacitance C_G and C_D built-in
- Alarm output function
- Reset function (optional seconds control function)
- Input chattering elimination function (AI/R)
- Chip form (CF5760××)

PAD LAYOUT

(Unit: mm)

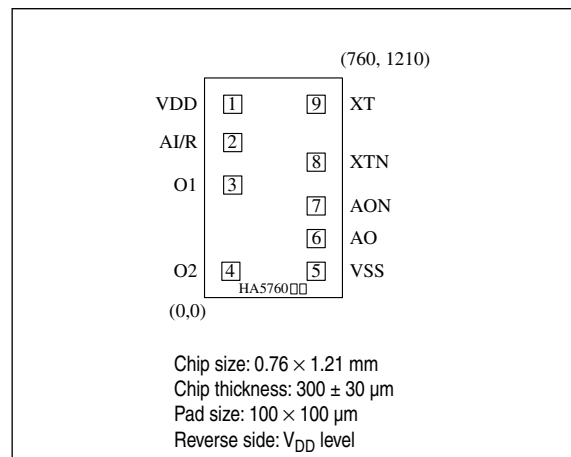

SERIES CONFIGURATION

		CF5760AA		CF5760BA		CF5760CC		CF5760DA		CF5760EA		CF5760FC		CF5760GB		CF5760HA		CF5760JA	
Built-in capacitance ¹	C_G [pF]	3		3		3		3		3		3		27		3		3	
	C_D [pF]	25		25		33		25		25		33		26		25		25	
Alarm input/reset input level		HIGH/LOW		HIGH/LOW		LOW/HIGH		LOW/HIGH		-/LOW		LOW/HIGH		LOW/HIGH		LOW/HIGH		LOW/HIGH	
Motor output	Active level	LOW		LOW		HIGH		LOW		-		-		HIGH		HIGH		-	
	Needle period t_{CY} [s]	1		1		1		1		1		0.0625		1		1		0.0625	
	Pulsewidth t_{PW} [ms]	23.4		23.4		31.25		27.3		1000		62.5		31.25		46.875		62.5	
Alarm output	Pins	AO	AON	AO	AON	AO	AON	AO	AON	AO	AON	AO	AON	AO	AON	AO	AON	AO	AON
	Active level	HIGH	LOW	HIGH	F (32kHz)	HIGH	LOW	HIGH	F (32kHz)	-	-	HIGH	LOW	HIGH	LOW	HIGH	LOW	HIGH	F (32kHz)
	Frequency f_{PW} [kHz]	4	4	DC	-	2	2	DC	-	-	-	2	2	2	2	2	2	DC	-
	Modulation f_{CY} [Hz]	8	8	-	-	8 + 1	8 + 1	-	-	-	-	8 + 1	8 + 1	8 + 1	8 + 1	8 + 1	8 + 1	-	-
	I_{OH} min [μA]	900	900	900	10	900	900	900	10	-	-	900	900	900	900	900	900	900	10
	I_{OL} min [μA]	900	900	10	10	900	900	10	10	-	-	900	900	10	10	900	900	10	10

1. Built-in capacitance includes the parasitic capacitance.

ORDERING INFORMATION

Device	Package
CF5760××	Chip form

BLOCK DIAGRAM

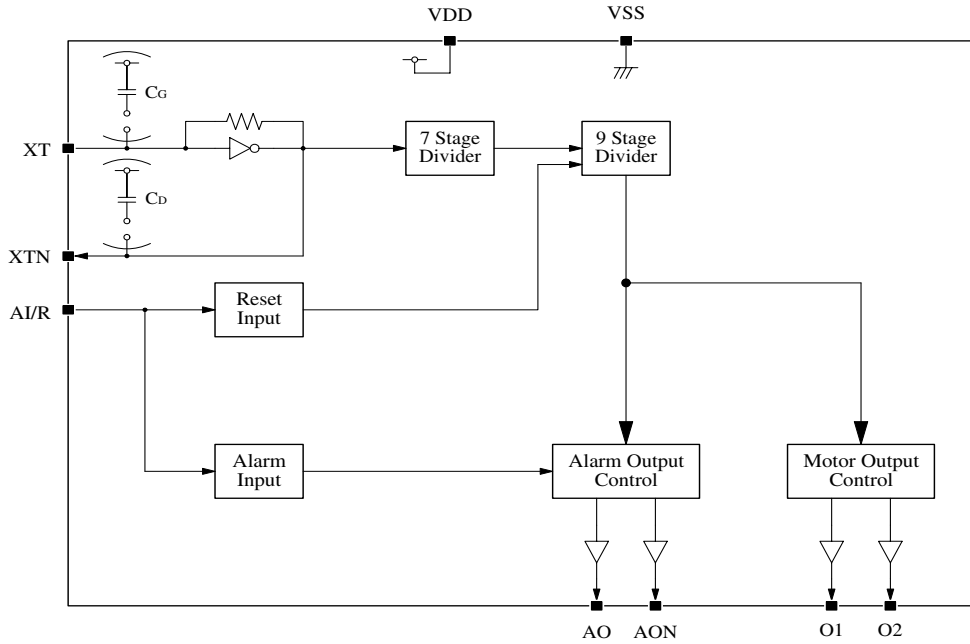

PAD DESCRIPTION/DIMENSIONS

No.	Name	Description	Dimensions [μm]	
			X	Y
1	VDD	Supply	155	1065
2	AI/R	Alarm input and reset input	155	854
3	O1	Motor output 1	155	620
4	O2	Motor output 2	145	145
5	VSS	Ground	615	145
6	AO	Alarm output 1	615	325
7	AON	Alarm output 2	615	505
8	XTN	Oscillator output	615	746
9	XT	Oscillator input	615	1065

SPECIFICATIONS

Absolute Maximum Ratings

Parameter	Symbol	Condition	Rating	Unit
Supply voltage range	$V_{DD} - V_{SS}$		-0.3 to 5.0	V
Input voltage range	V_{IN}		$V_{SS} \leq V_{IN} \leq V_{DD}$	V
Operating temperature range	T_{opr}		-30 to 80	°C
Storage temperature range	T_{stg}		-65 to 150	°C

Electrical Characteristics

$T_a = 25^\circ\text{C}$, $V_{DD} = 1.5\text{V}$, $V_{SS} = 0\text{V}$, $C_G = 23\text{pF}$, $C_D = 25\text{pF}$, X'tal ($f_0 = 32.768\text{kHz}$, $C_1 = 50\text{k}\Omega$ max) unless otherwise noted

Parameter	Symbol	Condition	Rating			Unit
			min	typ	max	
Operating voltage	V_{DD}		1.2	-	2.0	V
Current consumption	I_{DD}	O1 = O2 = open	-	1.2	4.0	μA
Oscillator start-up time	t_{STA}	$V_{DD} = 1.2\text{V}$	-	-	5.0	s
Motor output current	I_{MOT}	$V_{DD} = 1.2\text{V}$, $R_L = 200\Omega^1$	4.0	-	-	mA
AI/R HIGH-level input current	I_{IH}	$V_{DD} = 1.5\text{V}$	2	4	8	μA
AI/R LOW-level input current	I_{IL}	$V_{DD} = 1.5\text{V}$	2	4	8	μA
Oscillator frequency stability	$\Delta f/f$	$V_{DD} = 1.2$ to 2.0V	-	0.5	1.0	ppm/0.1V
Alarm LOW-level output current ² (AO, AON)	I_{OL1}	$V_{DD} = 1.5\text{V}$, $V_{OL} = 0.75\text{V}$	900	2000	-	μA
	I_{OL2}	$V_{DD} = 1.5\text{V}$, $V_{OL} = 0.75\text{V}$	10	30	-	μA
Alarm HIGH-level output current ² (AO, AON)	I_{OH1}	$V_{DD} = 1.5\text{V}$, $V_{OH} = 0.75\text{V}$	900	2000	-	μA
	I_{OH2}	$V_{DD} = 1.5\text{V}$, $V_{OH} = 0.75\text{V}$	10	30	-	μA
F output voltage ³	V_F	$V_{DD} = 1.2\text{V}$, $C_L = 50\text{pF}$	0.4	-	-	V
Internal capacitance ⁴	C_G		Refer to the SERIES LINEUP			pF
	C_D					pF

1. R_L is the load resistance connected between O1 and O2.

2. CF5760AA/ CC/ FC/ HA: If the outputs (AO or AON) are short circuit, the output current is $I_{AO} \geq 900 \mu\text{A}$.

3. The F output voltage rating, V_F , when a load capacitance, C_L , is connected between pin F and VSS, is the difference voltage between the center voltage, $0.5V_{DD}$, and the peak voltage.

4. C_G is the capacitance between VDD and XT. C_D is the capacitance between VDD and XTN.

FUNCTIONAL DESCRIPTION

Motor Output

Motor output waveform (step motor driver)

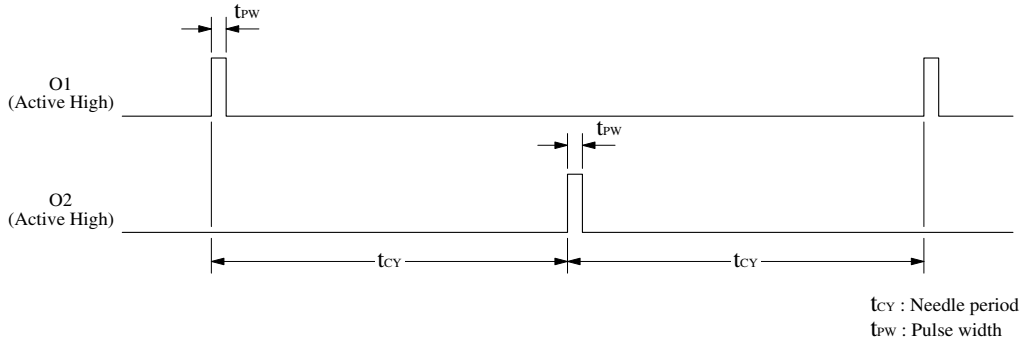

Motor output waveform (sweep motor driver)

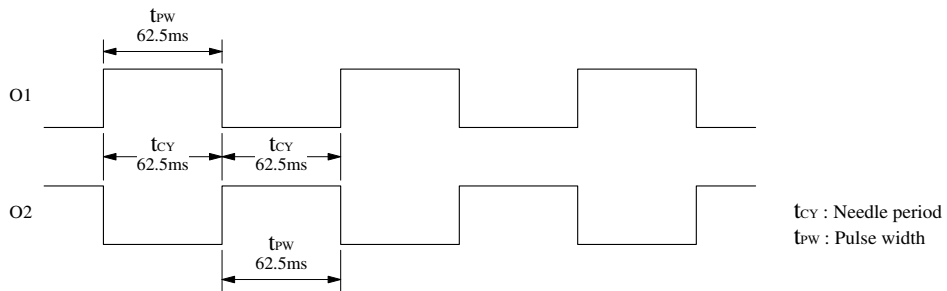

Input Chattering Elimination Function (AI/R)

A bounce delay is provided on the AI/R input to eliminate erroneous operation caused by input bounce (chattering).

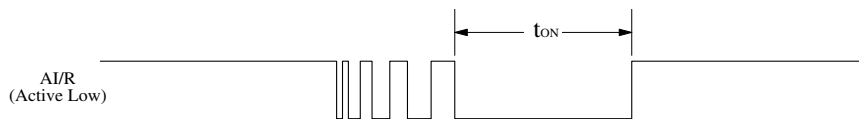

$t_{ON} < 62.5\text{ms}$: input is ignored.
 $62.5 \leq t_{ON} \leq 125\text{ms}$: indeterminate
 $t_{ON} > 125\text{ms}$: input is accepted.

Input Control Functions

When AI/R is open circuit, a 256Hz signal is output.

When AI/R is HIGH or LOW, it selects the alarm (HIGH)/reset (LOW) function or reset (HIGH)/alarm (LOW) function depending on the version.

Reset Function (optional seconds control function)

When AI/R goes active level for a reset, the motor output stops. When the reset is released, the first motor output pulse occurs on the output pin opposite to that which had the last output pulse immediately before the reset.

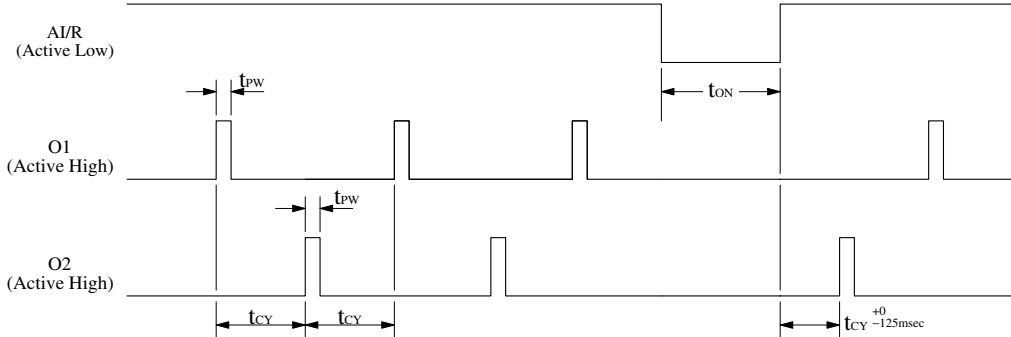

Alarm Output

Alarm output waveform

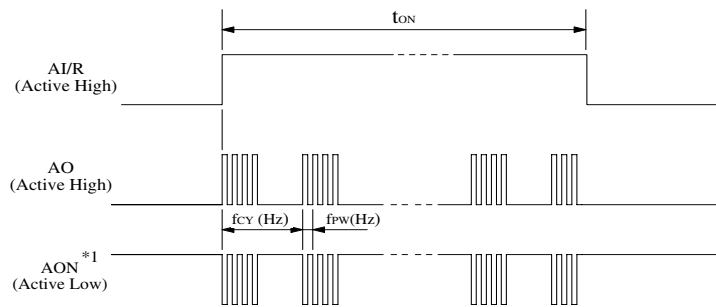

*1: Opposite phase to AO.

f_{PW} = alarm fundamental frequency

f_{CY} = alarm modulation frequency

F Output Function

The AON pin may be replaced by the F pin which is used to output a 32kHz signal (unaffected by the reset function).

TYPICAL APPLICATION CIRCUITS

Alarm (HIGH)/Reset (LOW), Piezoelectric alarm

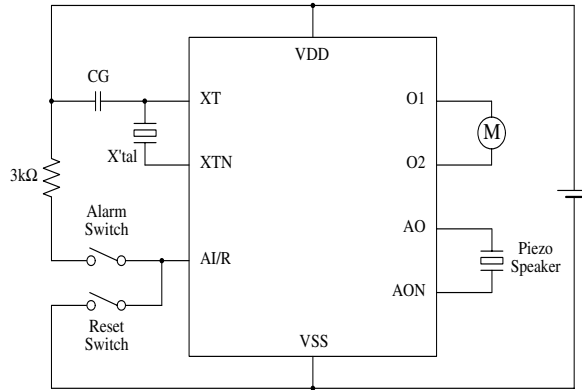

Reset (HIGH)/Alarm (LOW), DC Output, F Output

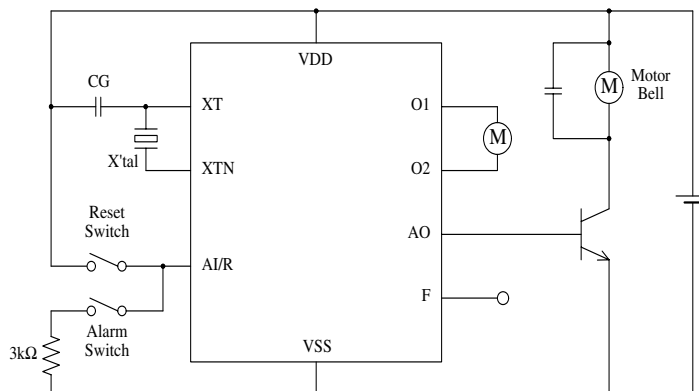

Please pay your attention to the following points at time of using the products shown in this document.

The products shown in this document (hereinafter "Products") are not intended to be used for the apparatus that exerts harmful influence on human lives due to the defects, failure or malfunction of the Products. Customers are requested to obtain prior written agreement for such use from SEIKO NPC CORPORATION (hereinafter "NPC"). Customers shall be solely responsible for, and indemnify and hold NPC free and harmless from, any and all claims, damages, losses, expenses or lawsuits, due to such use without such agreement. NPC reserves the right to change the specifications of the Products in order to improve the characteristic or reliability thereof. NPC makes no claim or warranty that the contents described in this document do not infringe any intellectual property right or other similar right owned by third parties. Therefore, NPC shall not be responsible for such problems, even if the use is in accordance with the descriptions provided in this document. Any descriptions including applications, circuits, and the parameters of the Products in this document are for reference to use the Products, and shall not be guaranteed free from defect, inapplicability to the design for the mass-production products without further testing or modification. Customers are requested not to export or re-export, directly or indirectly, the Products to any country or any entity not in compliance with or in violation of the national export administration laws, treaties, orders and regulations. Customers are requested appropriately take steps to obtain required permissions or approvals from appropriate government agencies.

The logo for NPC (Seiko NPC Corporation) consists of the letters 'NPC' in a bold, black, sans-serif font. The 'N' and 'P' are connected at the top, and the 'C' is positioned to the right of the 'P'.

SEIKO NPC CORPORATION

1-9-9, Hatchobori, Chuo-ku,
Tokyo 104-0032, Japan
Telephone: +81-3-5541-6501
Facsimile: +81-3-5541-6510
<http://www.npc.co.jp/>
Email: sales@npc.co.jp

NC9812DE 2006.04