

OVERVIEW

The 5086 series are differential LV-PECL output oscillator ICs that operate with 300MHz to 700MHz SAW resonators. The series includes devices with $f_o/4$ frequency output (mask option), making them ideal for low-frequency SAW oscillators as low as 75MHz. They are specialized for SAW oscillators, realizing smaller chip size compared to existing products. They feature low jitter, miniature LV-PECL output oscillator optimal to use in high-speed serial interface applications.

FEATURES

- 2.375 to 3.6V operating supply voltage range
- Recommended oscillation frequency range: 300MHz to 700MHz (varies with version)
- Output frequency range: 75MHz to 700MHz
 f_o , $f_o/2$, $f_o/4$ output frequency, determined by internal connection
- Output rise time/ Output fall time: 400ps (max)
- Low jitter (RMS jitter, 12kHz to 20MHz): 0.3ps (5086A2, $f_o = 312.5\text{MHz}$, $f_{OUT} = 156.25\text{MHz}$, $V_{CC} = 3.3\text{V}$, typ)
- -40 to +85°C operating temperature range
- Differential LV-PECL output
- 50Ω output load (terminated to $V_{CC} - 2\text{V}$)
- Standby function
 - Outputs are high impedance when OE is LOW. (oscillator stops)
- Power-saving pull-up resistor built-in (pin OE)
- BiCMOS process
- Chip form (CF5086××)

SERIES CONFIGURATION

Version	Recommended crystal unit/ resonator	Recommended oscillation frequency range ^{*1} [MHz]	Built-in capacitance ^{*2}		Output frequency
			C _{XIN}	C _{XOUT}	
5086A1	SAW	300 to 500	6	8	f_o
5086A2					$f_o/2$
5086A3					$f_o/4$
5086B1		500 to 700	5	5	f_o
5086B2					$f_o/2$
5086B3					$f_o/4$

*1. The recommended oscillation frequency is a yardstick value derived from the resonator used for NPC characteristics authentication. However, the oscillator frequency band is not guaranteed. Specifically, the characteristics can vary greatly due to resonator characteristics and mounting conditions, so the oscillation characteristics of components must be carefully evaluated.

*2. The oscillator internal capacitance values includes parasitic capacitance.

ORDERING INFORMATION

Device	Package	Version name
CF5086××-1	Chip form	<p style="text-align: center;">CF5086□□ - 1</p> <p>Form CF: Chip (Die) form</p> <p>Chip thickness: 300μm</p> <p>Frequency divider function</p> <p>Oscillation frequency range</p>

PAD LAYOUT

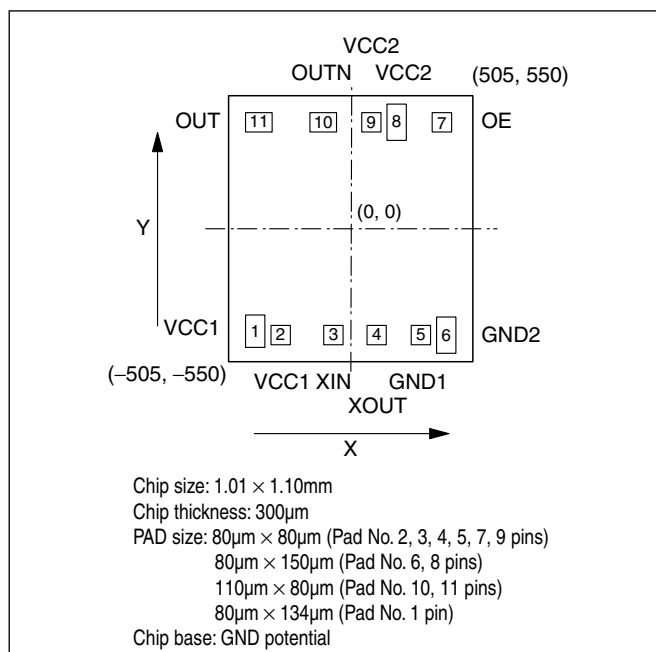
(Unit: μm)

PIN DESCRIPTION and PAD DIMENSIONS

Pad No.	Name	I/O ^{*1}	Function	Pad dimensions [μm]	
				X	Y
1	VCC1 ^{*2}	–	(+) supply pin (for oscillation circuit)	–395	–424
2	VCC1 ^{*2}	–		–290	–440
3	XIN	I	Oscillator input pin	–72	–440
4	XOUT	O	Oscillator output pin	107	–440
5	GND1 ^{*3}	–	(–) ground pin (for oscillation circuit)	290	–440
6	GND2 ^{*3}	–	(–) ground pin (for all circuits excluding oscillation circuit)	395	–440
7	OE	I	Output enable pin. Outputs are high impedance when LOW (oscillator stopped). Power-saving pull-up resistor built-in.	377	440
8	VCC2 ^{*2}	–	(+) output buffer supply pin (for all circuits excluding oscillation circuit)	190	440
9	VCC2 ^{*2}	–		85	440
10	OUTN	O	Complementary output pin. Disable: High impedance	–114	440
11	OUT	O	Output pin. Disable: High impedance	–380	440

*1. I: input, O: output

*2. Connect both of pins by wire-bonding for good characteristics.

*3. GND1 and GND2 pins should be connected by wire-bonding since they are disconnected.

BLOCK DIAGRAM

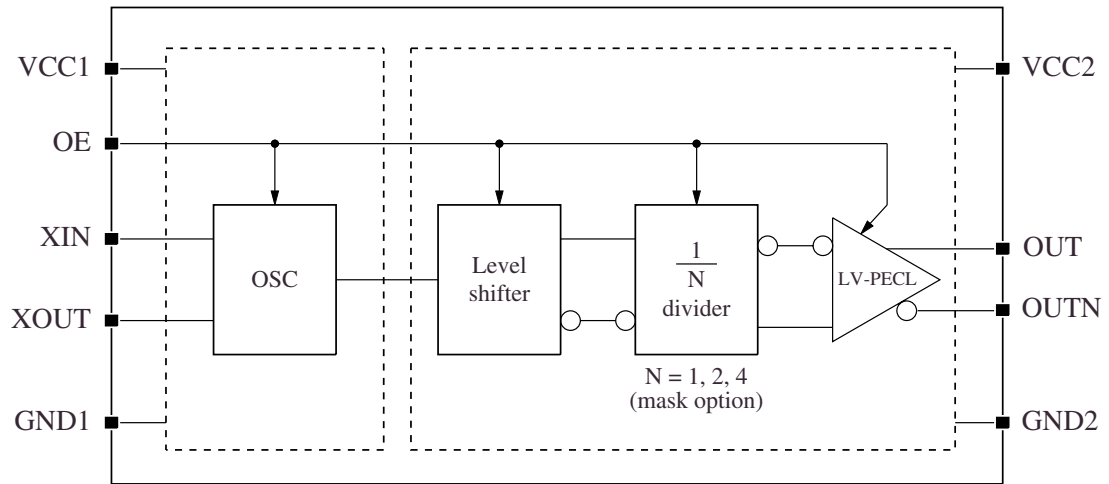

SPECIFICATIONS

Absolute Maximum Ratings

GND = 0V unless otherwise noted.

Parameter	Symbol	Conditions	Rating	Unit
Supply voltage range ^{*1}	V_{CC}	VCC1, VCC2 pins	-0.3 to +5.0	V
Input voltage range ^{*1 *2}	V_{IN}	XIN, OE pins	-0.3 to $V_{CC} + 0.3$	V
Output voltage range ^{*1 *2}	V_{OUT}	XOUT, OUT/OUTN pins	-0.3 to $V_{CC} + 0.3$	V
Junction temperature ^{*3}	T_J		+125	°C
Storage temperature range ^{*4}	T_{STG}	Chip form	-55 to +125	°C

*1. This parameter rating is the values that must never exceed even for a moment. This product may suffer breakdown if this parameter rating is exceeded. Operation and characteristics are guaranteed only when the product is operated at recommended operating conditions.

*2. V_{CC} is a V_{CC} value of recommended operating conditions.

*3. The device may be deteriorated the characteristics or reliability if this parameter rating is exceeded.

*4. When stored in nitrogen or vacuum atmosphere applied to IC itself only (excluding packaging materials).

Recommended Operating Conditions

GND = 0V unless otherwise noted.

Parameter	Symbol	Conditions	Rating			Unit
			Min	Typ	Max	
Operating supply voltage	V_{CC}	Between VCC1 and GND pins, Between VCC2 and GND pins	2.375	-	3.6	V
Operating supply voltage difference	ΔV_{CC}	Voltage difference between VCC1 and VCC2 pins	-0.1	-	+0.1	V
Input voltage	V_{IN}	XIN, OE pins	0	-	V_{CC}	V
Operating temperature	T_a		-40	-	+85	°C
Output load	R_L	Terminated to $V_{CC} - 2V$	49.5	50	50.5	Ω
Output frequency ^{*1}	f_{OUT}		75	-	700	MHz

*1. Output frequency varies by version. Refer to "SERIES CONFIGURATION".

Note. Since it may influence the reliability if it is used out of range of recommended operating conditions, this product should be used within this range.

Electrical Characteristics

3.3V operation

$V_{CC} = 3.0$ to $3.6V$, $GND = 0V$, $T_a = -40$ to $+85^{\circ}C$ unless otherwise noted.

Parameter	Symbol	Conditions	Rating			Unit	
			Min	Typ	Max		
Current consumption	I_{CC}	Measurement cct. 1, OE = open	–	74	97	mA	
Standby current	I_{STB}	Measurement cct. 1, OE = LOW	–	–	30	μA	
HIGH-level output voltage	V_{OH}	Measurement cct. 2, $V_{CC} = 3.3V$, OE = open, OUT/OUTN pins	$T_a = 0$ to $+85^{\circ}C$	2.275	2.350	2.420	V
			$T_a = -40^{\circ}C$ to $0^{\circ}C$	2.215	2.295	2.420	V
LOW-level output voltage	V_{OL}		$T_a = 0$ to $+85^{\circ}C$	1.490	1.600	1.680	V
			$T_a = -40^{\circ}C$ to $0^{\circ}C$	1.470	1.605	1.745	V
Output leakage current	I_Z	Measurement cct. 3, SW1 = HIGH or LOW, OE = LOW, OUT/OUTN pins	–	–	10	μA	
HIGH-level input voltage	V_{IH}	Measurement cct. 1, OE pin	$0.7V_{CC}$	–	–	V	
LOW-level input voltage	V_{IL}	Measurement cct. 1, OE pin	–	–	$0.3V_{CC}$	V	
HIGH-level input current	I_{IH}	Measurement cct. 1, $V_{IN} = 0.7V_{CC}$, OE pin	–10	–	–70	μA	
LOW-level input current	I_{IL}	Measurement cct. 1, $V_{IN} = 0V$, OE pin	–1	–	–15	μA	

2.5V operation

$V_{CC} = 2.375$ to $2.625V$, $GND = 0V$, $T_a = -40$ to $+85^{\circ}C$ unless otherwise noted.

Parameter	Symbol	Conditions	Rating			Unit	
			Min	Typ	Max		
Current consumption	I_{CC}	Measurement cct. 1, OE = open	–	72	94	mA	
Standby current	I_{STB}	Measurement cct. 1, OE = LOW	–	–	30	μA	
HIGH-level output voltage	V_{OH}	Measurement cct. 2, $V_{CC} = 2.5V$, OE = open, OUT/OUTN pins	$T_a = 0$ to $+85^{\circ}C$	1.475	1.550	1.760	V
			$T_a = -40^{\circ}C$ to $0^{\circ}C$	1.415	1.495	1.620	V
LOW-level output voltage	V_{OL}		$T_a = 0$ to $+85^{\circ}C$	0.690	0.800	1.095	V
			$T_a = -40^{\circ}C$ to $0^{\circ}C$	0.670	0.805	1.195	V
Output leakage current	I_Z	Measurement cct. 3, SW1 = HIGH or LOW, OE = LOW, OUT/OUTN pins	–	–	10	μA	
HIGH-level input voltage	V_{IH}	Measurement cct. 1, OE pin	$0.7V_{CC}$	–	–	V	
LOW-level input voltage	V_{IL}	Measurement cct. 1, OE pin	–	–	$0.3V_{CC}$	V	
HIGH-level input current	I_{IH}	Measurement cct. 1, $V_{IN} = 0.7V_{CC}$, OE pin	–10	–	–70	μA	
LOW-level input current	I_{IL}	Measurement cct. 1, $V_{IN} = 0V$, OE pin	–1	–	–15	μA	

Switching Characteristics

3.3V operation

$V_{CC} = 3.0$ to $3.6V$, $GND = 0V$, $T_a = -40$ to $+85^\circ C$ unless otherwise noted.

Parameter	Symbol	Conditions	Rating			Unit	
			Min	Typ	Max		
Output duty cycle 1	Duty1	Measurement cct. 4, measured at output crossing point, $T_a = +25^\circ C$, $V_{CC} = 3.3V$	45	–	55	%	
Output duty cycle 2	Duty2	Measurement cct. 4, measured at 50% output swing, $T_a = +25^\circ C$, $V_{CC} = 3.3V$	5086×2, 5086×3	45	–	55	%
			5086×1	40	–	60	%
Output swing	V_{OPP}	Measurement cct. 4, Peak to peak of single output waveform	0.4	–	–	V	
Output rise time	t_r	Measurement cct. 4, 20 to 80% output swing	–	250	400	ps	
Output fall time	t_f	Measurement cct. 4, 80 to 20% output swing	–	250	400	ps	
Output disable time	t_{OD}	Measurement cct. 5, $T_a = +25^\circ C$ (refer to "Timing chart" on page 7 for more information.)	–	–	200	ns	

Note. The ratings are measured by using the NPC standard resonator and jig. They may vary due to resonator characteristics, so they must be carefully evaluated.

Recommended resonator characteristics: A version: $R1 \leq 20\Omega$, $C0 \leq 3pF$

B version: $R1 \leq 20\Omega$, $C0 \leq 2pF$

2.5V operation

$V_{CC} = 2.375$ to $2.625V$, $GND = 0V$, $T_a = -40$ to $+85^\circ C$ unless otherwise noted.

Parameter	Symbol	Conditions	Rating			Unit	
			Min	Typ	Max		
Output duty cycle 1	Duty1	Measurement cct. 4, measured at output crossing point, $T_a = +25^\circ C$, $V_{CC} = 2.5V$	45	-	55	%	
Output duty cycle 2	Duty2	Measurement cct. 4, measured at 50% output swing, $T_a = +25^\circ C$, $V_{CC} = 2.5V$	5086×2, 5086×3	45	-	55	%
			5086×1	40	-	60	%
Output swing	V_{OPP}	Measurement cct. 4, Peak to peak of single output waveform	0.2	-	-	V	
Output rise time	t_r	Measurement cct. 4, 20 to 80% output swing	-	250	400	ps	
Output fall time	t_f	Measurement cct. 4, 80 to 20% output swing	-	250	400	ps	
Output disable time	t_{OD}	Measurement cct. 5, $T_a = +25^\circ C$ (refer to "Timing chart" below for more information.)	-	-	200	ns	

Note. The ratings are measured by using the NPC standard resonator and jig. They may vary due to resonator characteristics, so they must be carefully evaluated.

Recommended resonator characteristics: A version: $R1 \leq 20\Omega$, $C0 \leq 3pF$
 B version: $R1 \leq 20\Omega$, $C0 \leq 2pF$

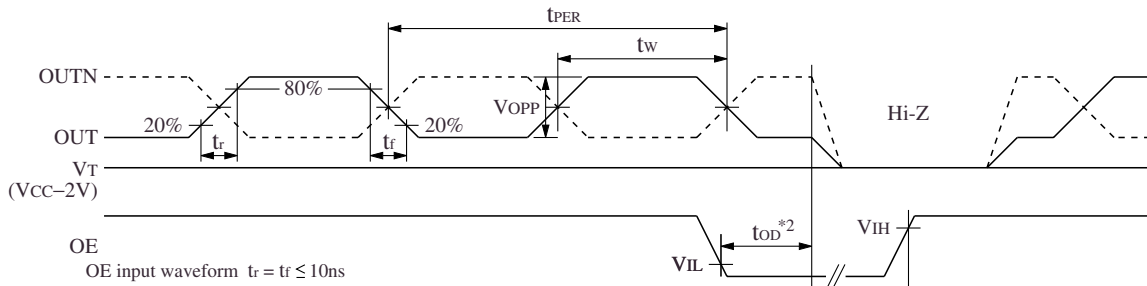

$DUTY1 = t_w / t_{PER} \times 100$ (%) @ crossing point
 $DUTY2 = t_w / t_{PER} \times 100$ (%) @ 50% waveform

*2. The OUT/OUTN output goes high impedance after the OE is fallen and then the output disable time " t_{OD} " has elapsed. The output signal is pulled down to V_T (terminated voltage) by load resistance.

Timing chart

MEASUREMENT CIRCUITS

- Note: Bypass capacitors specified in each measurement circuit below should be connected between VCC and GND, and V_T and GND. Load resistance specified in each measurement circuit below should be connected to OUT and OUTN pins (excluding measurement circuit 3).

Circuit wiring of bypass capacitors and load resistance should be connected as short as possible. If the circuit wiring is long, the required characteristics may not be realized. Also, if the values of bypass capacitors and load resistance differ from the description in this document or are not connected, the required characteristics may not be realized.

* The capacitor and resistor used in measurement circuits below;
 GRM155F11H103Z (MURATA) 0.01 μ F
 RN732ATTD49R9B25 (KOA) 49.9 Ω

Measurement Circuit 1

Measurement parameter: I_{CC} , I_{STB} , I_{IH} , I_{IL} , V_{IH} , V_{IL}

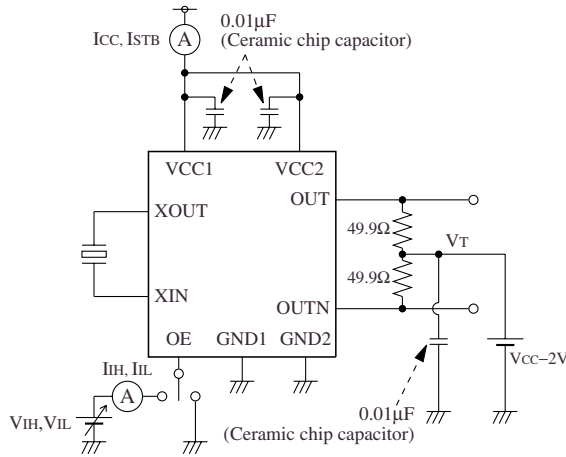

Measurement Circuit 2

Measurement parameter: V_{OH} , V_{OL}

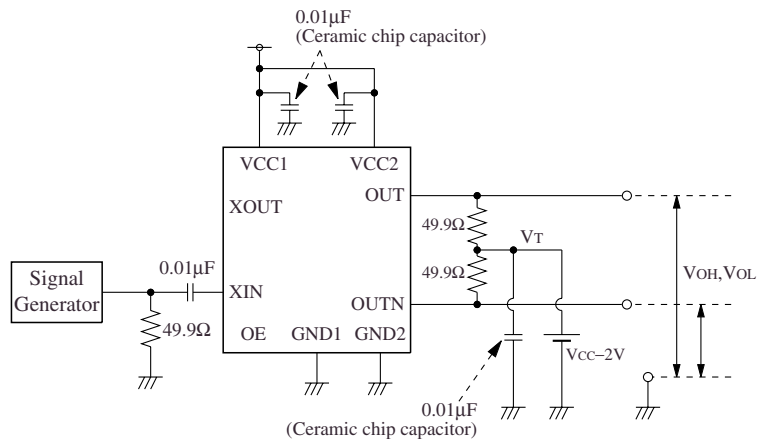

Input signal: 500mVp-p, sin waveform, 10MHz to 40MHz

Measurement Circuit 3

Measurement parameter: I_Z

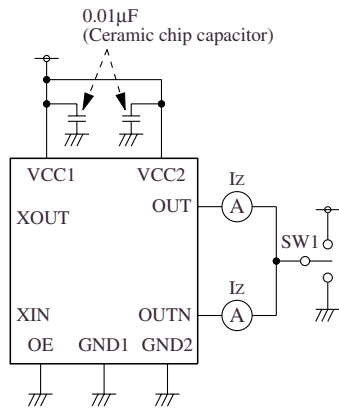

Measurement Circuit 4

Measurement parameter: Duty1, Duty2, V_{OPP} , t_r , t_f

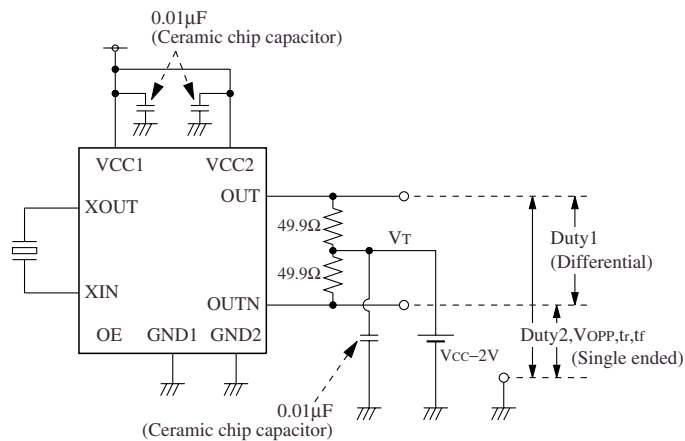

Measurement Circuit 5

Measurement parameter: t_{OD}

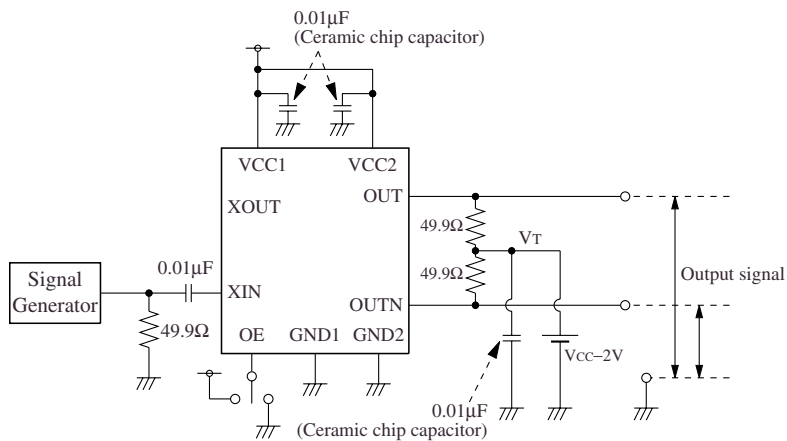

Input signal: 500mVp-p, sin waveform, t_{OD} : OE = V_{CC} to GND

FUNCTIONAL DESCRIPTION

Standby Function

When OE goes LOW, the oscillator stops and the output pins (OUT, OUTN) become high impedance.

OE	OUT, OUTN	Oscillator
HIGH (or open)	Any f_O , $f_O/2$ or $f_O/4$ output frequency	Normal operation
LOW	High impedance	Stopped

Power-saving Pull-up Resistor

The OE pin pull-up resistance changes in response to the input level (HIGH or LOW). When OE is tied LOW (standby state), the pull-up resistance becomes large, reducing the current consumed by the resistance. When OE is open circuit, the pull-up resistance becomes small, decreasing the susceptibility to the effects of external noise.

Oscillation Detector Function

The 5086 series also feature an oscillation detector circuit. This circuit functions to disable the outputs until the oscillator circuit starts and oscillation becomes stable. This alleviates the danger of abnormal oscillator output at oscillator start-up when power is applied or when OE is switched.

TYPICAL PERFORMANCE

The following characteristics measured using the NPC's standard jig and SAW resonator. Note that the characteristics will vary with the resonator used or measurement condition.

■ SAW resonator used for measurement

Parameter	$f_0 = 433\text{MHz}$
C0 [pF]	2.3
R1 [Ω]	25

■ SAW resonator parameters

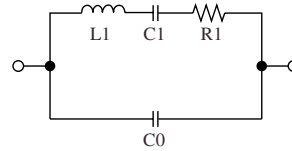

Current Consumption

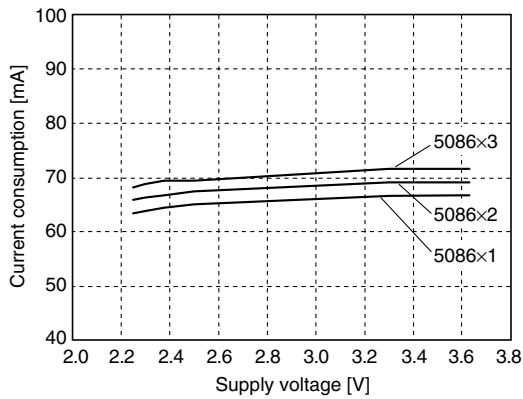

$T_a = 25^\circ\text{C}$

Negative Resistance

Measurement equipment: Agilent 4396B Network Analyzer, Agilent 85046A S-parameter Test Set

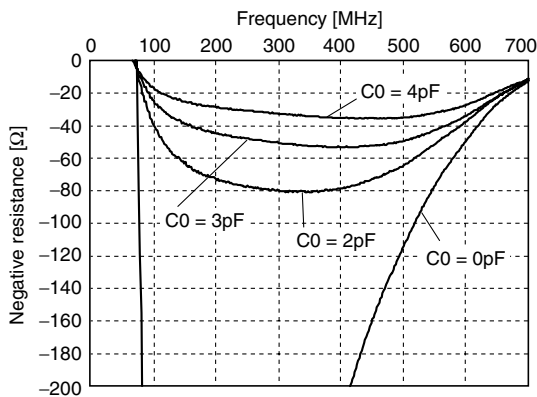

5086Ax, $V_{CC} = 3.3\text{V}$, $T_a = 25^\circ\text{C}$

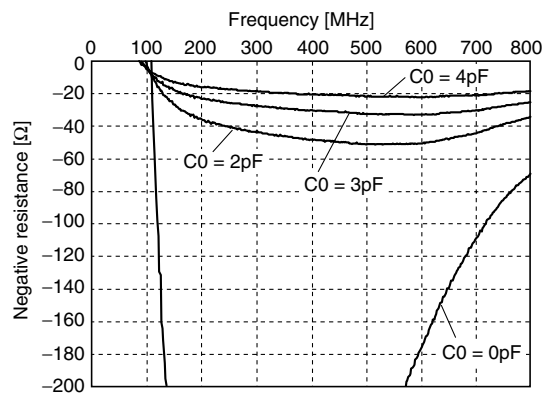

5086Bx, $V_{CC} = 3.3\text{V}$, $T_a = 25^\circ\text{C}$

Characteristics are measured with a capacitance C0, representing the resonator equivalent circuit C0 capacitance, connected between the XIN and XOUT pins. Measurements are performed with Agilent 4396B, 85046A using the NPC test jig. Characteristics may vary with measurement jig and measurement conditions.

Phase Noise

Measurement equipment: Agilent E5052B Signal Source Analyzer

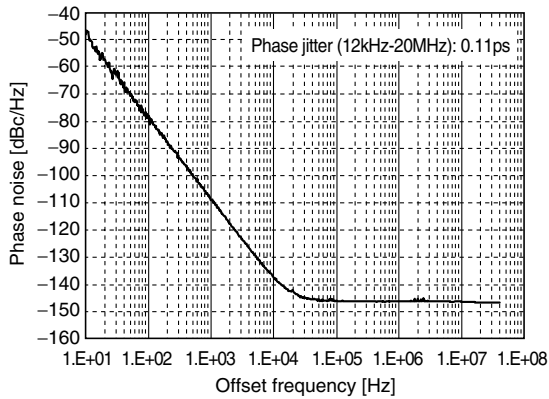

5086A1, $V_{CC} = 3.3V$, $f_O = 433MHz$,
 $f_{OUT} = 433MHz$, $T_a = 25^\circ C$

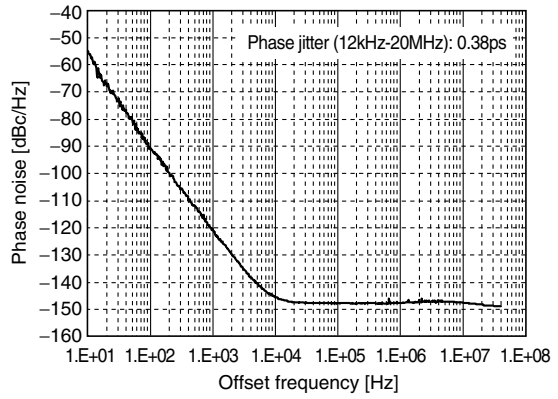

5086A3, $V_{CC} = 3.3V$, $f_O = 433MHz$,
 $f_{OUT} = 108.25MHz$, $T_a = 25^\circ C$

Output Waveform

Measurement equipment: Agilent DSO80604B Oscilloscope



5086A3, $V_{CC} = 3.3V$, $f_O = 433MHz$,
 $f_{OUT} = 108.25MHz$, $T_a = 25^\circ C$

Please pay your attention to the following points at time of using the products shown in this document.

1. The products shown in this document (hereinafter "Products") are designed and manufactured to the generally accepted standards of reliability as expected for use in general electronic and electrical equipment, such as personal equipment, machine tools and measurement equipment. The Products are not designed and manufactured to be used in any other special equipment requiring extremely high level of reliability and safety, such as aerospace equipment, nuclear power control equipment, medical equipment, transportation equipment, disaster prevention equipment, security equipment. The Products are not designed and manufactured to be used for the apparatus that exerts harmful influence on the human lives due to the defects, failure or malfunction of the Products. If you wish to use the Products in that apparatus, please contact our sales section in advance.
In the event that the Products are used in such apparatus without our prior approval, we assume no responsibility whatsoever for any damages resulting from the use of that apparatus.
2. NPC reserves the right to change the specifications of the Products in order to improve the characteristics or reliability thereof.
3. The information described in this document is presented only as a guide for using the Products. No responsibility is assumed by us for any infringements of patents or other rights of the third parties which may result from its use. No license is granted by implication or otherwise under any patents or other rights of the third parties. Then, we assume no responsibility whatsoever for any damages resulting from that infringements.
4. The constant of each circuit shown in this document is described as an example, and it is not guaranteed about its value of the mass-production products.
5. In the case of that the Products in this document falls under the foreign exchange and foreign trade control law or other applicable laws and regulations, approval of the export to be based on those laws and regulations are necessary. Customers are requested appropriately take steps to obtain required permissions or approvals form appropriate government agencies.

The logo for NPC (Seiko NPC Corporation) consists of the letters 'NPC' in a bold, black, sans-serif font. The 'N' and 'P' are connected at the top, and the 'C' is positioned to the right of the 'P'.

SEIKO NPC CORPORATION

1-9-9, Hatchobori, Chuo-ku,
Tokyo 104-0032, Japan
Telephone: +81-3-5541-6501
Facsimile: +81-3-5541-6510
<http://www.npc.co.jp/>
Email: sales@npc.co.jp