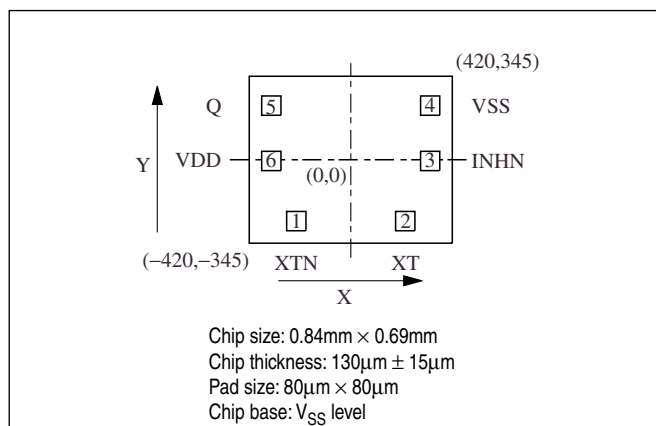

SERIES CONFIGURATION

Version name	Operating supply voltage range [V]	Output frequency f_{OUT} (divider ratio)
5042A1A	2.25 to 3.63	f_{OSC}
5042A2A		$f_{OSC}/2$
5042A3A		$f_{OSC}/4$
5042A4A		$f_{OSC}/8$
5042B1A	1.60 to 2.25	f_{OSC}
5042B2A		$f_{OSC}/2$
5042B3A		$f_{OSC}/4$

PAD LAYOUT

(Unit: μm)

PAD DIMENSIONS PIN DESCRIPTION

Pad No.	Pin	I/O ^{*1}	Name	Description	Pad dimensions [μm]	
					X	Y
1	XTN	O	Amplifier output	Crystal connection pins. Crystal is connected between XT and XTN.	-225.2	-253.5
2	XT	I	Amplifier input		225.2	-253.5
3	INH	I	Output state control input	High impedance when LOW (oscillator stops). Power-saving pull-up resistor built-in.	328.5	-5.0
4	VSS	-	(-) ground	-	328.5	223.8
5	Q	O	Output	Output frequency determined by internal circuit to one of f_{OSC} , $f_{OSC}/2$, $f_{OSC}/4$, $f_{OSC}/8$. ^{*2} High impedance in standby mode	-328.5	223.8
6	VDD	-	(+) supply voltage	-	-328.5	-5.0

*1. I: Input, O: Output

*2. $f_{OSC}/8$: 5042A4A version only

BLOCK DIAGRAM

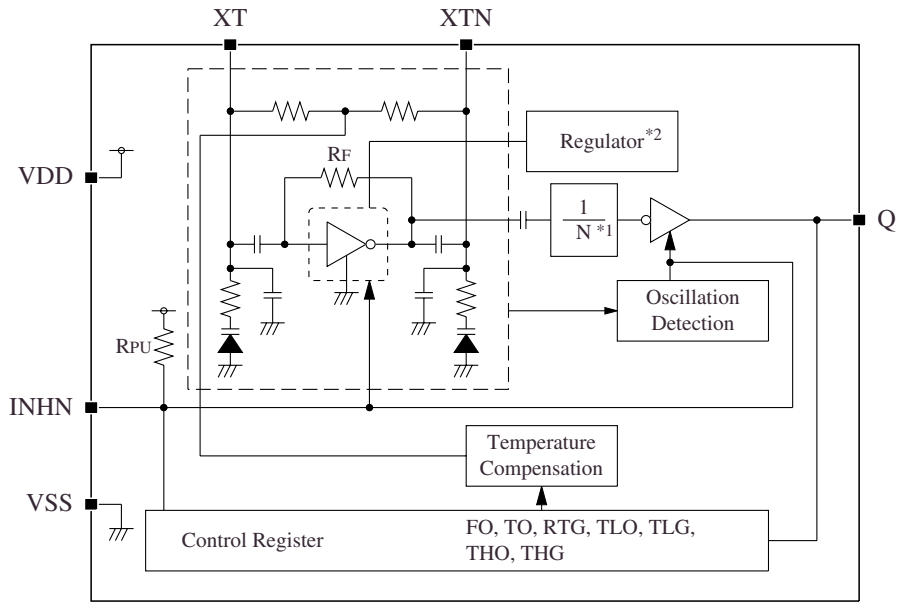

*1. 5042AxA version: N = 1, 2, 4, 8 (mask option)
 5042BxA version: N = 1, 2, 4 (mask option)
 *2. 5042AxA version only

ABSOLUTE MAXIMUM RATINGS

$V_{SS} = 0V$ unless otherwise noted.

Parameter	Symbol	Conditions	Rating	Unit
Supply voltage range ^{*1}	V_{DD}	Between VDD and VSS	-0.3 to +4.0	V
Program read/write input voltage range ^{*1}	V_{PP}	Between INHN and VSS	-0.3 to +16.5	V
Input voltage range ^{*1 *2}	V_{IN}	Input pins	-0.3 to $V_{DD} + 0.3$	V
Output voltage range ^{*1 *2}	V_{OUT}	Output pins	-0.3 to $V_{DD} + 0.3$	V
Output current ^{*1}	I_{OUT}	Q pin	± 20	mA
Storage temperature range ^{*3}	T_{STG}	Chip form	-65 to +150	°C
EEPROM maximum writes	N_{EW}		100	times

*1. This parameter rating is the values that must never exceed even for a moment. This product may suffer breakdown if this parameter rating is exceeded. Operation and characteristics are guaranteed only when the product is operated at recommended operating conditions.

*2. V_{DD} is a V_{DD} value of recommended operating conditions.

*3. When stored in nitrogen or vacuum atmosphere applied to IC itself only (excluding packaging materials).

RECOMMENDED OPERATING CONDITIONS

$V_{SS} = 0V$ unless otherwise noted.

Parameter	Symbol	Conditions	Rating			Unit	
			Min	Typ	Max		
Supply voltage	V_{DD}	Between VDD and VSS	5042AxA	2.25	-	3.63	V
			5042BxA	1.60	-	2.25	V
Input voltage	V_{IN}	Input pins (XT, INHN)	V_{SS}	-	V_{DD}	V	
Operating temperature	T_{OPR}		-40	-	+85	°C	
Oscillation frequency ^{*1}	f_{OSC}	5042AxA	20	-	55	MHz	
		5042BxA	20	-	55	MHz	
Output frequency ^{*1}	f_{OUT}	Q pin	5042AxA	2.5	-	55	MHz
			5042BxA	5	-	55	MHz
Output load capacitance	C_{LOUT}	Q pin	-	-	15	pF	

*1. The recommended oscillation frequency is a yardstick value derived from the crystal used for NPC characteristics authentication. However, the oscillation frequency range is not guaranteed. Specifically, the characteristics can vary greatly due to crystal characteristics and mounting conditions, so the oscillation characteristics of components must be carefully evaluated.

- Mount a ceramic chip capacitor that is larger than 0.01 μ F proximal to IC (within approximately 3mm) between VDD and VSS in order to obtain stable operation of 5042 series. In addition, the wiring pattern between IC and capacitor should be as wide as possible.
- Since it may influence the reliability if it is used out of range of recommended operating conditions, this product should be used within this range.

ELECTRICAL CHARACTERISTICS

DC Characteristics (5042A1A to A4A)

$V_{DD} = 2.25V$ to $3.63V$, $V_{SS} = 0V$, $T_{OPR} = -40^{\circ}C$ to $+85^{\circ}C$, $C_{LOUT} = 15pF$ unless otherwise noted.

Parameter	Symbol	Conditions	Rating			Unit	
			MIN	TYP	MAX		
Operating-mode current consumption ^{*1}	I_{DD}	5042A1A ($f_{OUT} = f_{OSC}$), Measurement circuit 1, no load, INHN = HIGH, $f_{OSC} = 48MHz$	$V_{DD} = 2.5V$	–	1.4	2.8	mA
			$V_{DD} = 3.3V$	–	1.7	3.4	mA
		5042A2A ($f_{OUT} = f_{OSC}/2$), Measurement circuit 1, no load, INHN = HIGH, $f_{OSC} = 48MHz$	$V_{DD} = 2.5V$	–	1.1	2.2	mA
			$V_{DD} = 3.3V$	–	1.4	2.7	mA
		5042A3A ($f_{OUT} = f_{OSC}/4$), Measurement circuit 1, no load, INHN = HIGH, $f_{OSC} = 48MHz$	$V_{DD} = 2.5V$	–	1.0	1.9	mA
			$V_{DD} = 3.3V$	–	1.2	2.4	mA
		5042A4A ($f_{OUT} = f_{OSC}/8$), Measurement circuit 1, no load, INHN = HIGH, $f_{OSC} = 48MHz$	$V_{DD} = 2.5V$	–	0.9	1.7	mA
			$V_{DD} = 3.3V$	–	1.0	2.1	mA
Standby-mode current consumption	I_{ST}	Measurement circuit 1, INHN = LOW	–	–	10	μA	
HIGH-level output voltage	V_{OH}	Q pin, Measurement circuit 3, $I_{OH} = -4mA$	$V_{DD}-0.4$	–	–	V	
LOW-level output voltage	V_{OL}	Q pin, Measurement circuit 3, $I_{OL} = 4mA$	–	–	0.4	V	
Output leakage current	I_Z	Measurement circuit 4, INHN = LOW	$Q = V_{DD}$	–	–	10	μA
			$Q = V_{SS}$	–10	–	–	μA
HIGH-level input current	V_{IH}	INHN pin, Measurement circuit 5	$0.7V_{DD}$	–	–	V	
LOW-level input current	V_{IL}		–	–	$0.3V_{DD}$	V	
INHN pull-up resistance	R_{PU1}	Measurement circuit 6	INHN = V_{SS}	0.4	1.5	10	$M\Omega$
	R_{PU2}		INHN = $0.7V_{DD}$	50	100	200	$k\Omega$

*1. The consumption current I_{DD} (C_{LOUT}) with a load capacitance (C_{LOUT}) connected to the Q pin is given by the following equation, where I_{DD} is the no-load consumption current and f_{OUT} is the output frequency.

$$I_{DD} (C_{LOUT}) [mA] = I_{DD} [mA] + C_{LOUT} [pF] \times V_{DD} [V] \times f_{OUT} [MHz] \times 10^{-3}$$

5042 series

DC Characteristics (5042B1A to B3A)

$V_{DD} = 1.60\text{V}$ to 2.25V , $V_{SS} = 0\text{V}$, $T_{OPR} = -40^{\circ}\text{C}$ to $+85^{\circ}\text{C}$, $C_{LOUT} = 15\text{pF}$ unless otherwise noted.

Parameter	Symbol	Conditions	Rating			Unit	
			MIN	TYP	MAX		
Operating-mode current consumption ^{*1}	I_{DD}	5042B1A ($f_{OUT} = f_{OSC}$), Measurement circuit 1, no load, INHN = HIGH, $f_{OSC} = 48\text{MHz}$, $V_{DD} = 1.8\text{V}$	–	1.7	3.4	mA	
		5042B2A ($f_{OUT} = f_{OSC}/2$), Measurement circuit 1, no load, INHN = HIGH, $f_{OSC} = 48\text{MHz}$, $V_{DD} = 1.8\text{V}$	–	1.5	3.3	mA	
		5042B3A ($f_{OUT} = f_{OSC}/4$), Measurement circuit 1, no load, INHN = HIGH, $f_{OSC} = 48\text{MHz}$, $V_{DD} = 1.8\text{V}$	–	1.4	3.2	mA	
Standby-mode current consumption	I_{ST}	Measurement circuit 1, INHN = LOW	–	–	10	μA	
HIGH-level output voltage	V_{OH}	Q pin, Measurement circuit 3, $I_{OH} = -4\text{mA}$	$V_{DD}-0.4$	–	–	V	
LOW-level output voltage	V_{OL}	Q pin, Measurement circuit 3, $I_{OL} = 4\text{mA}$	–	–	0.4	V	
Output leakage current	I_Z	Measurement circuit 4, INHN = LOW	Q = V_{DD}	–	–	10	μA
			Q = V_{SS}	–10	–	–	μA
HIGH-level input current	V_{IH}	INHN pin, Measurement circuit 5	$0.7V_{DD}$	–	–	V	
LOW-level input current	V_{IL}		–	–	$0.3V_{DD}$	V	
INHN pull-up resistance	R_{PU1}	Measurement circuit 6	INHN = V_{SS}	0.4	1.5	10	$\text{M}\Omega$
	R_{PU2}		INHN = $0.7V_{DD}$	50	100	200	$\text{k}\Omega$

*1. The consumption current I_{DD} (C_{LOUT}) with a load capacitance (C_{LOUT}) connected to the Q pin is given by the following equation, where I_{DD} is the no-load consumption current and f_{OUT} is the output frequency.

$$I_{DD}(C_{LOUT}) [\text{mA}] = I_{DD} [\text{mA}] + C_{LOUT} [\text{pF}] \times V_{DD} [\text{V}] \times f_{OUT} [\text{MHz}] \times 10^{-3}$$

AC Characteristics

Clock output characteristics (5042A1A to A4A, Q pin)

$V_{DD} = 2.25V$ to $3.63V$, $V_{SS} = 0V$, $T_{OPR} = -40^{\circ}C$ to $+85^{\circ}C$, $C_{LOUT} = 15pF$ unless otherwise noted.

Parameter	Symbol	Conditions	Rating			Unit
			MIN	TYP	MAX	
Output rise time	t_r	Measurement circuit 1, $0.1V_{DD} \rightarrow 0.9V_{DD}$	-	-	4.5	ns
Output fall time	t_f	Measurement circuit 1, $0.9V_{DD} \rightarrow 0.1V_{DD}$	-	-	4.5	ns
Output duty cycle ^{*1}	Duty	Measurement circuit 1, threshold voltage $0.5V_{DD}$, Duty = $T_w/T \times 100$	45	50	55	%
Output enable delay time ^{*2}	t_{OE}	Measurement circuit 2 ^{*3} , INHN = LOW \rightarrow HIGH	-	-	10	μs
Output disable delay time	t_{OD}	Measurement circuit 2 ^{*3} , INHN = HIGH \rightarrow LOW	-	-	100	ns

Clock output characteristics (5042B1A to B3A, Q pin)

$V_{DD} = 1.60V$ to $2.25V$, $V_{SS} = 0V$, $T_{OPR} = -40^{\circ}C$ to $+85^{\circ}C$, $C_{LOUT} = 15pF$ unless otherwise noted.

Parameter	Symbol	Conditions	Rating			Unit
			MIN	TYP	MAX	
Output rise time	t_r	Measurement circuit 1, $0.1V_{DD} \rightarrow 0.9V_{DD}$	-	-	5	ns
Output fall time	t_f	Measurement circuit 1, $0.9V_{DD} \rightarrow 0.1V_{DD}$	-	-	5	ns
Output duty cycle ^{*1}	Duty	Measurement circuit 1, threshold voltage $0.5V_{DD}$, Duty = $T_w/T \times 100$	45	50	55	%
Output enable delay time ^{*2}	t_{OE}	Measurement circuit 2 ^{*3} , INHN = LOW \rightarrow HIGH	-	-	10	μs
Output disable delay time	t_{OD}	Measurement circuit 2 ^{*3} , INHN = HIGH \rightarrow LOW	-	-	100	ns

*1. This parameter is measured using the NPC's standard crystal. Note that the values will vary with the crystal characteristics used or mounting conditions.

*2. Oscillator stop function is built-in. When INHN goes LOW, normal output stops. When INHN goes HIGH, normal output is not resumed until after the oscillator start-up time has elapsed.

*3. Measurement circuit 2 takes an external input on the XT pin, without using a crystal.

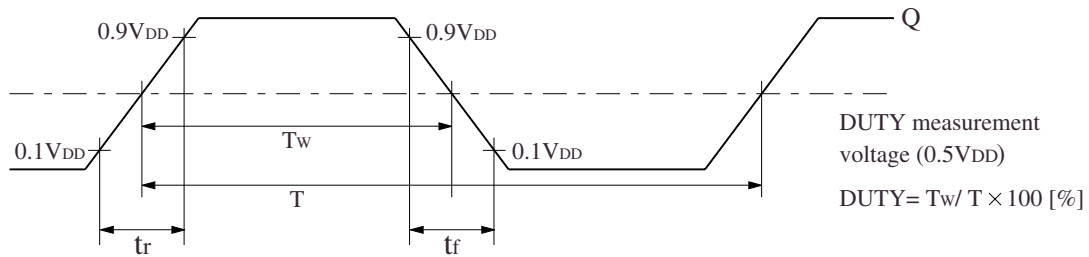

Figure 1. Output switching waveform

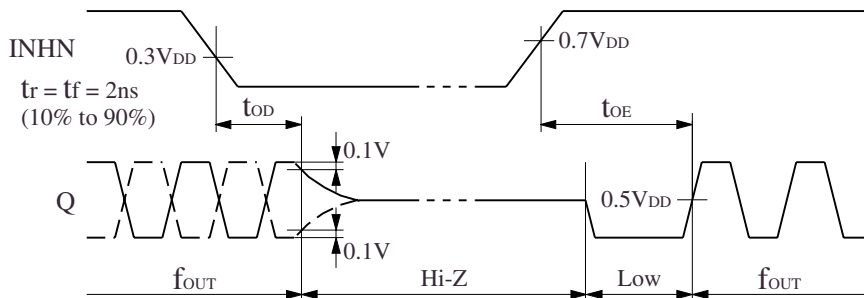
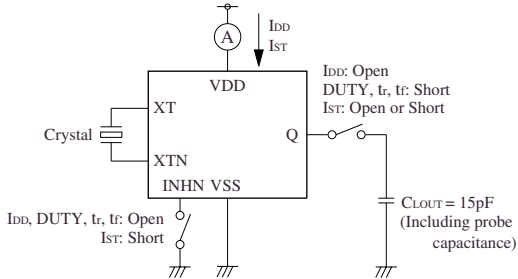

Figure 2. Output disable timing chart

MEASUREMENT CIRCUITS

Measurement Circuit 1

Parameters: I_{DD} , I_{ST} , Duty, t_r , t_f



Note: The AC characteristics are observed using an oscilloscope on pin Q.

Measurement Circuit 2

Parameters: t_{OD} , t_{OE}

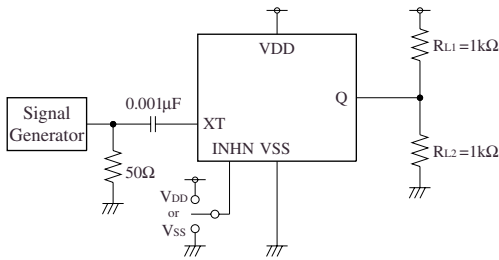

XT input signal: 1Vp-p, sine wave

Measurement Circuit 3

Parameters: V_{OH} , V_{OL}

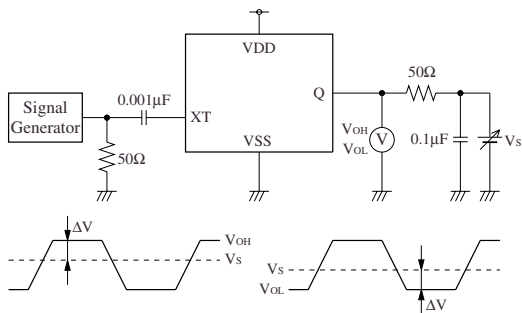

V_S adjusted such that $\Delta V = 50 \times I_{OH}$.

V_S adjusted such that $\Delta V = 50 \times I_{OL}$.

XT input signal: 1Vp-p, sine wave

Measurement Circuit 4

Parameters: I_Z

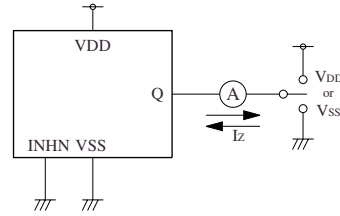

Measurement Circuit 5

Parameters: V_{IH} , V_{IL}

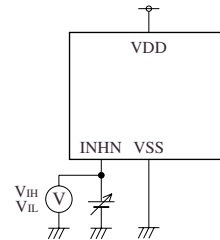

Measurement Circuit 6

Parameters: R_{PU1} , R_{PU2}

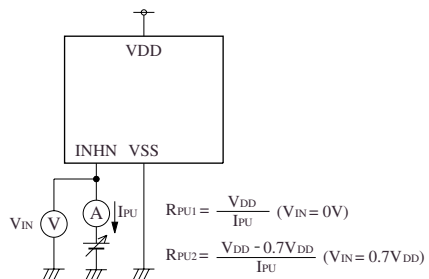

FUNCTIONAL DESCRIPTION

Frequency Adjustment Function

The 5042 series ICs have a built-in oscillator frequency adjustment function. The frequency adjustment settings are written to and stored in internal EEPROM, making the devices easy to setup. A typical compensation sequence is shown below.

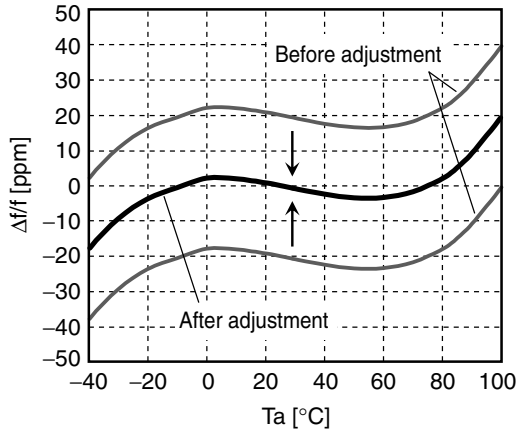

Figure 3. Center frequency adjustment

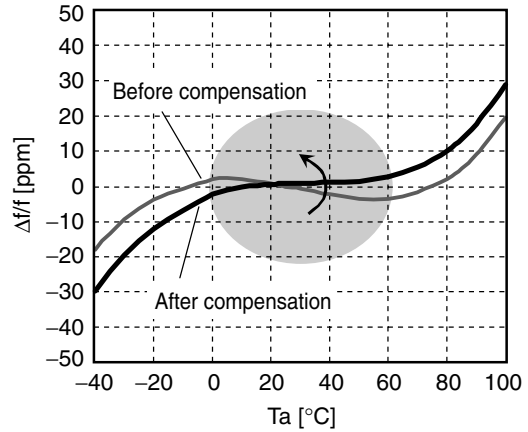

Figure 4. Temperature rotation compensation

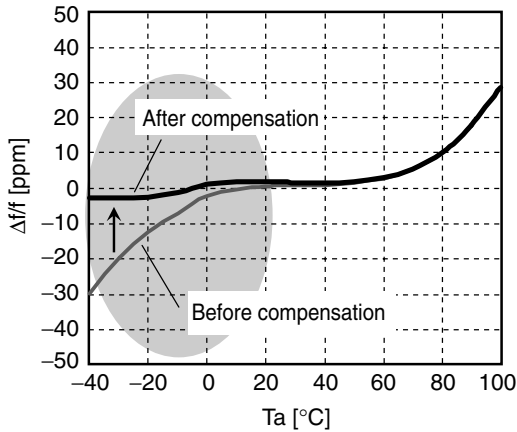

Figure 5. Low-temperature characteristics compensation

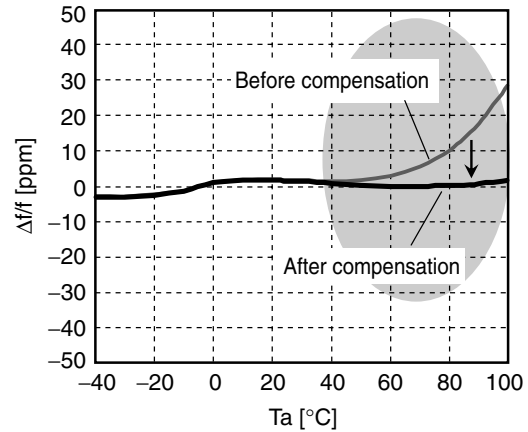

Figure 6. High-temperature characteristics compensation

Power-saving Pull-up Resistor

The INHN pin pull-up resistance R_{PU1} or R_{PU2} changes in response to the input level (open, HIGH, or LOW). When INHN is tied LOW level, the pull-up resistance is large (R_{PU1}), reducing the current consumed by the resistance. When INHN is left open circuit (HIGH), the pull-up resistance is small (R_{PU2}), which decreases the input susceptibility to external noise. The pull-up resistance ties the INHN pin HIGH level, helping to avoid problems such as the output stopping unexpectedly.

Oscillation Detector Function

The 5042 series also feature an oscillation detector circuit. This circuit functions to disable the outputs until the oscillator circuit starts and oscillation becomes stable. This alleviates the danger of abnormal oscillator output at oscillator start-up when power is applied or when INHN is switched.

USAGE NOTES

Consideration for Mounting IC

A ceramic chip capacitor that is larger than $0.01\mu\text{F}$ should be mounted proximal to IC (within approximately 3mm) between VDD and VSS in order to obtain stable operation of 5042 series. In addition, the wiring pattern between IC and capacitor should be as wide as possible.