

OVERVIEW

The SM5002L series crystal oscillator module ICs fabricated in NPC's Molybdenum-gate CMOS. They comprise low-voltage low-current consumption oscillator circuits and output buffers. They incorporate built-in oscillation capacitance with superior frequency response to realize stable 3rd overtone oscillation without any external components.

FEATURES

- Oscillation frequency up to 100MHz
- 3rd overtone oscillation
- 2.7 to 3.6V supply voltage
- Capacitors C_G and C_D built-in
- Inverter amplifier feedback resistance built-in
- CMOS input level
- Output three-state function
- Standby function (oscillator stops)
- $3\mu\text{A}$ (typ) low standby current
- 8mA ($V_{DD} = 3.0\text{V}$) output drive capability
- Oscillator frequency output
- CMOS output duty level
- INHN pin pull-up resistance built-in
 - INHN = L: $2\text{M}\Omega$ typ
 - INHN = H: $90\text{k}\Omega$ typ
- 8-pin SOP (SM5002L×S)
- Chip form (CF5002L×)

SERIES CONFIGURATION

Version	Recommended operating frequency range ¹ [MHz]	gm ratio	Built-in capacitance		R_{f1} [k Ω]	C_f [pF]	Output duty level	Output current [mA]	Standby function
			C_G [pF]	C_D [pF]					
CF5002LA SM5002LAS	30 to 40	1.0	8	15	5.6	22	CMOS	8	Yes
CF5002LB SM5002LBS	40 to 60	1.5	8	15	4.7	22	CMOS	8	Yes
CF5002LC SM5002LCS	50 to 70	1.5	8	10	3.9	22	CMOS	8	Yes
CF5002LD SM5002LDS	70 to 90	2.0	8	10	3.9	22	CMOS	8	Yes
CF5002LE SM5002LES	85 to 100	2.0	8	10	2.7	22	CMOS	8	Yes
CF5002LF SM5002LFS	25 to 30	1.0	10	15	8.5	22	CMOS	8	Yes

1. The recommended operating frequency is a yardstick value derived from the crystal used for NPC characteristics authentication. However, the oscillator frequency band is not guaranteed. Specifically, the characteristics can vary greatly due to crystal characteristics and mounting conditions, so the oscillation characteristics of components must be carefully evaluated.

ORDERING INFORMATION

Device	Package
SM5002L×S	8-pin SOP
CF5002L×-1	Chip form
CF5002L×-2	

PACKAGE DIMENSIONS

(Unit: mm)

- 8-pin SOP

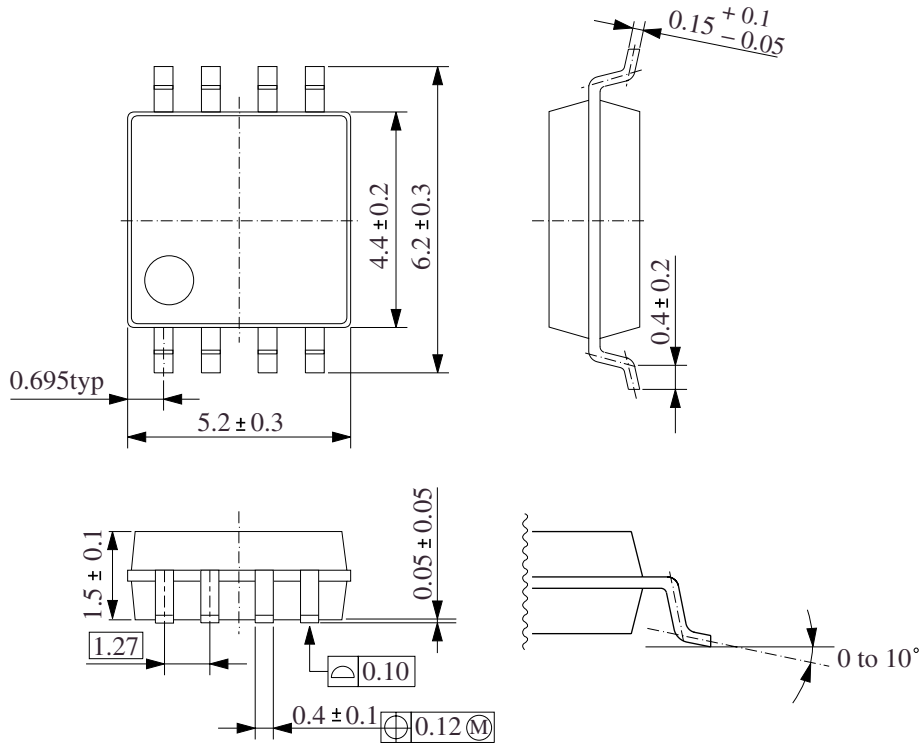

PAD LAYOUT

(Unit: μm)

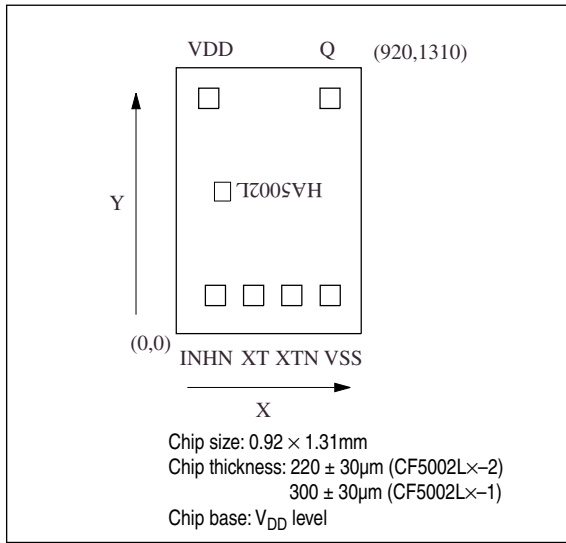

PINOUT

(Top view)

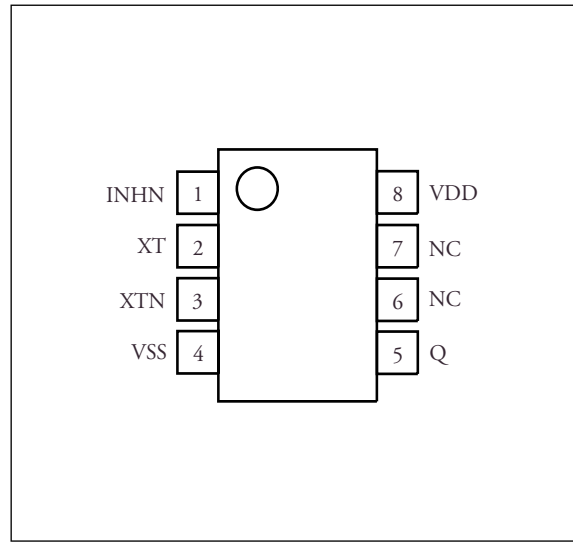

PIN DESCRIPTION and PAD DIMENSIONS

Number	Name	I/O	Description	Pad dimensions [μm]	
				X	Y
1	INHN	I	Output state control input. Oscillator stopped when LOW. Power-saving pull-up resistor built in	195	188
2	XT	I	Amplifier input.	385	188
3	XTN	O	Amplifier output.		
			Crystal oscillator connection pins. Crystal oscillator connected between XT and XTN	575	188
4	VSS	-	Ground	766	188
5	Q	O	Output. Output frequency. High impedance at standby operation	765	1159
6	NC	-	No connection	-	-
7	NC	-	No connection	-	-
8	VDD	-	Supply voltage	162	1159

BLOCK DIAGRAM

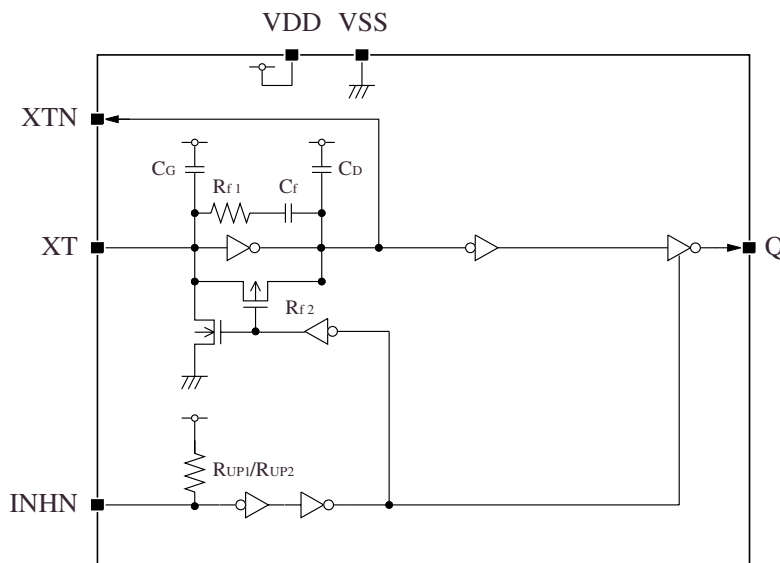

SPECIFICATIONS

Absolute Maximum Ratings

$V_{SS} = 0V$ unless otherwise noted.

Parameter	Symbol	Condition	Rating	Unit
Supply voltage range	V_{DD}		-0.5 to 7.0	V
Input voltage range	V_{IN}		-0.5 to $V_{DD} + 0.5$	V
Output voltage range	V_{OUT}		-0.5 to $V_{DD} + 0.5$	V
Operating temperature range	T_{opr}		-40 to 85	°C
Storage temperature range	T_{stg1}	Chip form	-65 to 150	°C
	T_{stg2}	8-pin SOP	-40 to 125	
Output current	I_{OUT}		25	mA
Power dissipation	P_D	$T_a \leq 85^\circ\text{C}$, 8-pin SOP	200	mW

Recommended Operating Conditions

CF5002L× series (Chip form)

$V_{SS} = 0V$ unless otherwise noted.

Parameter	Symbol	Conditions	Rating			Units
			min	typ	max	
Supply voltage	V_{DD}	$C_L \leq 15\text{pF}$, $f \leq 70\text{MHz}$	2.7	-	3.6	V
		$C_L \leq 15\text{pF}$, $70 < f \leq 100\text{MHz}$	3.0	-	3.6	V
		$C_L \leq 30\text{pF}$, $f \leq 70\text{MHz}$	3.0	-	3.6	V
Input voltage	V_{IN}		V_{SS}	-	V_{DD}	V
Operating temperature	T_{OPR}		-20	-	80	°C

SM5002L×S series (8-pin SOP)

$V_{SS} = 0V$ unless otherwise noted.

Parameter	Symbol	Conditions	Rating			Units
			min	typ	max	
Supply voltage	V_{DD}	$C_L \leq 15\text{pF}$, $f \leq 50\text{MHz}$	2.7	-	3.6	V
		$C_L \leq 15\text{pF}$, $50 < f \leq 70\text{MHz}$	3.0	-	3.6	V
		$C_L \leq 30\text{pF}$, $f \leq 50\text{MHz}$	3.0	-	3.6	V
Input voltage	V_{IN}		V_{SS}	-	V_{DD}	V
Operating temperature	T_{OPR}		-20	-	80	°C

SM5002L series

Electrical Characteristics

$V_{DD} = 2.7$ to $3.6V$, $V_{SS} = 0V$, $T_a = -20$ to $80^{\circ}C$, unless otherwise noted.

Parameter	Symbol	Conditions	Rating			Units	
			min	typ	max		
HIGH-level output voltage	V_{OH}	Q: Measurement cct 1, $V_{DD} = 2.7V$, $I_{OH} = 8mA$	2.2	2.4	–	V	
LOW-level output voltage	V_{OL}	Q: Measurement cct 2, $V_{DD} = 2.7V$, $I_{OL} = 8mA$	–	0.3	0.4	V	
Output leakage current	I_z	Q: Measurement cct 2, INHN = LOW, $V_{DD} = 3.6V$	$V_{OH} = V_{DD}$	–	–	10	μA
		$V_{OL} = V_{SS}$	–	–	10	μA	
HIGH-level input voltage	V_{IH}	INHN pin	$0.7V_{DD}$	–	–	V	
LOW-level input voltage	V_{IL}	INHN pin	–	–	$0.3V_{DD}$	V	
Current consumption	I_{DD}	INHN = open, Measurement cct 3, load cct 1, $V_{DD} = 3.0$ to $3.6V$	SM5002LAS, CF5002LA SM5002LFS, CF5002LF $C_L = 30pF$, $f = 30MHz$	–	10	18	mA
			SM5002LBS, CF5002LB $C_L = 30pF$, $f = 50MHz$	–	15	25	mA
			SM5002LCS, CF5002LC $C_L = 30pF$, $f = 70MHz$	–	20	35	mA
			SM5002LDS, CF5002LD SM5002LES, CF5002LE $C_L = 15pF$, $f = 100MHz$	–	25	45	mA
Standby current	I_{ST}	INHN = LOW, Measurement cct 3	–	3	10	μA	
INHN pull-up resistance	R_{UP1}	Measurement cct 4, INHN = LOW	0.4	–	4	$M\Omega$	
	R_{UP2}	Measurement cct 4, INHN = $0.7V_{DD}$	50	–	150	$k\Omega$	
AC feedback resistance	R_{f1}	Design value. A monitor pattern on a wafer is tested.	SM5002LAS, CF5002LA	4.7	5.6	6.5	$k\Omega$
			SM5002LBS, CF5002LB	4.0	4.7	5.4	$k\Omega$
			SM5002LCS, CF5002LC SM5002LDS, CF5002LD	3.3	3.9	4.5	$k\Omega$
			SM5002LES, CF5002LE	2.2	2.7	3.2	$k\Omega$
			SM5002LFS, CF5002LF	7.2	8.5	9.8	$k\Omega$
DC feedback resistance	R_{f2}	Measurement cct 5	50	–	150	$k\Omega$	
AC feedback capacitance	C_f	Design value. A monitor pattern on a wafer is tested.	19.8	22	24.2	pF	
Built-in capacitance	C_G	Design value. A monitor pattern on a wafer is tested.	SM5002LAS, CF5002LA SM5002LBS, CF5002LB SM5002LCS, CF5002LC SM5002LDS, CF5002LD SM5002LES, CF5002LE	7.2	8	8.8	pF
			SM5002LFS, CF5002LF	9	10	11	pF
	C_D		SM5002LAS, CF5002LA SM5002LBS, CF5002LB SM5002LFS, CF5002LF	13.5	15	16.5	pF
			SM5002LCS, CF5002LC SM5002LDS, CF5002LD SM5002LES, CF5002LE	9	10	11	pF

Switching Characteristics

$V_{SS} = 0V$, $T_a = -20$ to $80^\circ C$ unless otherwise noted.

Parameter	Symbol	Conditions	Rating			Units	
			min	typ	max		
Output rise time	t_{r1}	Measurement cct 3, load cct 1, $0.1V_{DD} \rightarrow 0.9V_{DD}$	$V_{DD} = 2.7$ to $3.6V$, $C_L = 15pF$	–	2	4	ns
	t_{r2}		$V_{DD} = 3.0$ to $3.6V$, $C_L = 30pF$	–	2.5	5	ns
Output fall time	t_{f1}	Measurement cct 3, load cct 1, $0.9V_{DD} \rightarrow 0.1V_{DD}$	$V_{DD} = 2.7$ to $3.6V$, $C_L = 15pF$	–	2	4	ns
	t_{f2}		$V_{DD} = 3.0$ to $3.6V$, $C_L = 30pF$	–	2.5	5	ns
Output duty cycle ¹	DUTY	Measurement cct 3, load cct 1, $T_a = 25^\circ C$, $V_{DD} = 3.0V$	SM5002LAS, SM5002LFS CF5002LA, CF5002LF $C_L = 30pF$, $f = 30MHz$	45	–	55	%
			SM5002LBS, CF5002LB $C_L = 30pF$, $f = 50MHz$	45	–	55	%
			SM5002LCS, CF5002LC $C_L = 30pF$, $f = 70MHz$	45	–	55	%
			SM5002LDS, SM5002LES $C_L = 15pF$, $f = 100MHz$	40	–	60	%
			CF5002LD, CF5002LE $C_L = 15pF$, $f = 100MHz$	45	–	55	%
Output disable delay time ²	t_{PLZ}	Measurement cct 6, $T_a = 25^\circ C$, $V_{DD} = 2.7V$, load $C_L \leq 15pF$		–	–	100	ns
Output enable delay time ²	t_{PZL}			–	–	100	ns

1. The duty cycle characteristic is checked the sample chips of each production lot.

2. Oscillator stop function is built-in. When INHN goes LOW, normal output stops. When INHN goes HIGH, normal output is not resumed until after the oscillator start-up time has elapsed.

Current consumption and Output waveform with NPC's standard crystal

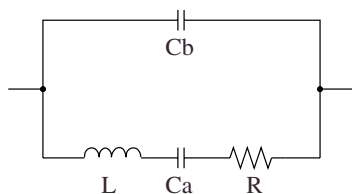

f [MHz]	R [Ω]	L [mH]	Ca [fF]	Cb [pF]
30	18.62	16.24	1.733	5.337
50	22.17	7.40	1.370	4.105
70	25.42	4.18	1.254	5.170
100	16.60	3.56	0.726	5.394

FUNCTIONAL DESCRIPTION

Standby Function

The oscillator stops when INHN goes LOW. When the oscillator stops, the oscillator output on Q goes high impedance.

INHN	Q	Oscillator
HIGH (or open)	f_O output frequency	Normal operation
LOW	High impedance	Stopped

MEASUREMENT CIRCUITS

Measurement cct 1

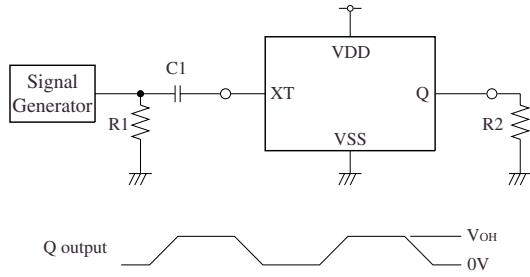

2.5V_{p-p}, 10MHz sine wave input signal
 C1 : 0.001μF
 R1 : 50Ω
 R2 : 275Ω

Measurement cct 4

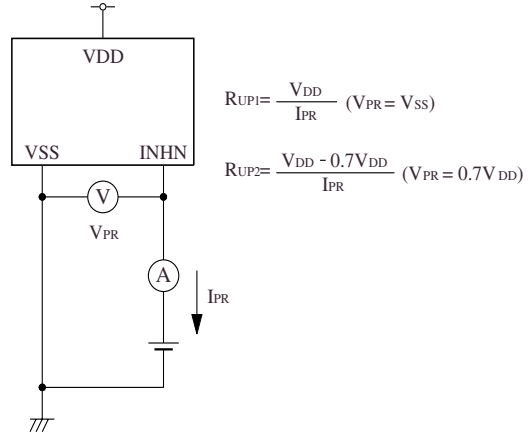

Measurement cct 2

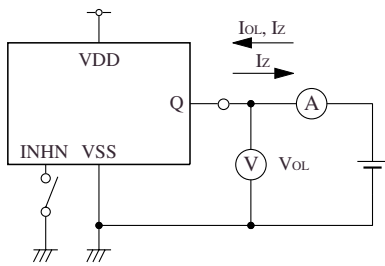

Measurement cct 5

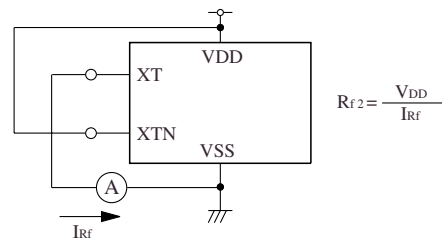

Measurement cct 3

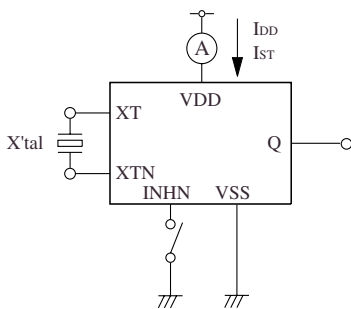

Measurement cct 6

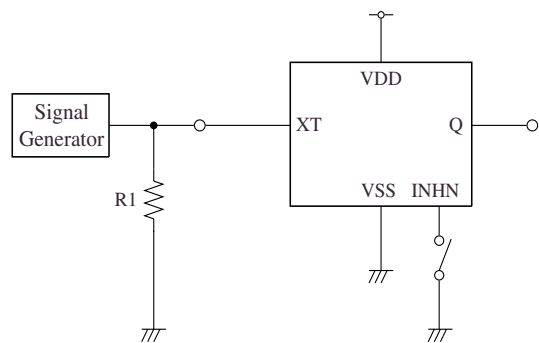

R1 : 50Ω

Please pay your attention to the following points at time of using the products shown in this document.

The products shown in this document (hereinafter "Products") are not intended to be used for the apparatus that exerts harmful influence on human lives due to the defects, failure or malfunction of the Products. Customers are requested to obtain prior written agreement for such use from SEIKO NPC CORPORATION (hereinafter "NPC"). Customers shall be solely responsible for, and indemnify and hold NPC free and harmless from, any and all claims, damages, losses, expenses or lawsuits, due to such use without such agreement. NPC reserves the right to change the specifications of the Products in order to improve the characteristic or reliability thereof. NPC makes no claim or warranty that the contents described in this document dose not infringe any intellectual property right or other similar right owned by third parties. Therefore, NPC shall not be responsible for such problems, even if the use is in accordance with the descriptions provided in this document. Any descriptions including applications, circuits, and the parameters of the Products in this document are for reference to use the Products, and shall not be guaranteed free from defect, inapplicability to the design for the mass-production products without further testing or modification. Customers are requested not to export or re-export, directly or indirectly, the Products to any country or any entity not in compliance with or in violation of the national export administration laws, treaties, orders and regulations. Customers are requested appropriately take steps to obtain required permissions or approvals from appropriate government agencies.

The logo for SEIKO NPC CORPORATION, consisting of the letters 'NPC' in a bold, black, sans-serif font.

SEIKO NPC CORPORATION

1-9-9, Hatchobori, Chuo-ku,
Tokyo 104-0032, Japan
Telephone: +81-3-5541-6501
Facsimile: +81-3-5541-6510
<http://www.npc.co.jp/>
Email: sales@npc.co.jp

NC9505FE 2008.08