

FEATURES

- Large active area
- Low noise
- High sensitivity
- Custom gains available
- Hermetically sealed TO-39

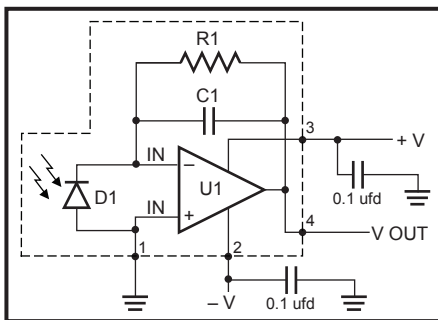

ELECTRO-OPTICAL CHARACTERISTICS AT 23°C

PARAMETERS	TEST CONDITIONS	MIN	TYP	MAX	UNITS
Dark Offset	$V_s = \pm 5 V$		1	± 2	mV
Dark Offset Noise	$V_s = \pm 5$ BW = 0.1 to 135 Hz		283	500	μV rms
Sensitivity	$V_s = \pm 5 V$ $\lambda = 940 \text{ nm}$	290	315		$V/\mu W$
Frequency Response (-3 db)	$V_s = \pm 5 V$ $\lambda = 940 \text{ nm}$	100	130		Hz
NEP	$\lambda = 940 \text{ nm}$		0.06		pW/\sqrt{Hz}
Transimpedance Gain			500		$M\Omega$
Supply Current			850	950	μA

THERMAL PARAMETERS

Voltage Supplies	± 5 to $\pm 15V$
Power Dissipation	30 mW
Storage and Operating Temperature	-25° to $+100^\circ C$
Soldering Temperature (1/16" from case for 3 seconds max)	$+260^\circ C$



750 Mitchell Road, Newbury Park, California 91320
 Phone: (805) 499-0335, Fax: (805) 499-8108
 Email: sales@optodiode.com, Website: www.optodiode.com

