

GMR Switch™ Precision Digital Sensors

When GMR sensor elements are combined with digital on-board signal processing electronics, the result is the GMR Switch. The GMR Switch offers unmatched precision and flexibility in magnetic field sensing.

The GMR Switch will accurately and reliably sense magnetic fields with less error than any other magnetic sensor on the market today. In addition, there is little shift in the magnetic field operate point of the GMR Switch over voltage and temperature extremes. This gives NVE's customer the ability to make a high precision, high tolerance magnetic sensing assembly.

The GMR switch can operate over a wide range of magnetic fields, and is the most precise magnetic sensor on the market. It is the clear choice when a digital output signal is required of a magnetic sensor.

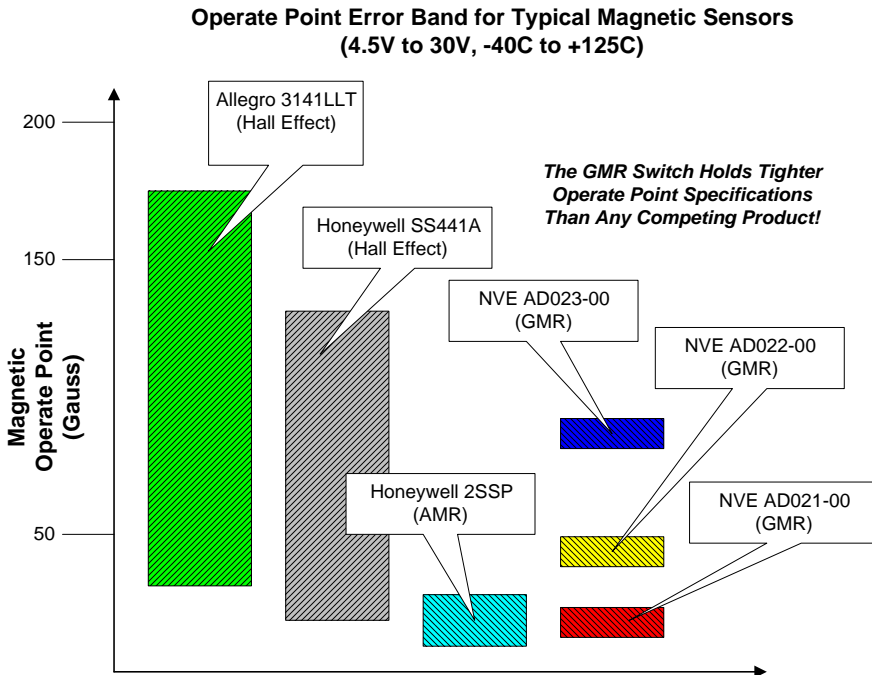

Quick Reference: GMR Switch Digital Sensors

The following table lists some of NVE's most popular GMR Switch products and their key specifications:

Part Number	Typical Magnetic Operate Point (Oe ¹)	Typical Magnetic Release Point (Oe ¹)	Output Type ²	Maximum Operation Temperature (°C)	Package Type ³
NVE AD004-02	20	10	Sink	125	SOIC8
NVE AD005-02	40	25	Sink	125	SOIC8
NVE AD021-00	20	10	Sink	125	MSOP8
NVE AD022-00	40	25	Sink	125	MSOP8
NVE AD024-00	28	14	Sink	125	MSOP8
NVE AD124-00	28	14	Source	125	MSOP8
NVE AD621-00	20	10	Sink + Source	125	MSOP8
NVE AD824-00	28	18	2 Sinks + SCP	125	MSOP8
NVE ADH025-00	11	5	Sink	150	MSOP8

Notes:

- 1 Oersted (Oe) = 1 Gauss in air
- 2 Output Types:
Sink = Up to 20mA current sink
Source = Up to 20mA current source
SCP = Short Circuit Protection available for external transistor
- 3 See Appendix for package dimensions

Note on Availability of Products

NVE keeps about 25 of the most popular types of GMR Switch products in stock at our manufacturing facility. However, because there are over 100 different varieties of GMR Switch parts, some part numbers may require a 6 to 8 week lead time before production quantities are available. Please contact NVE for further information.

GMR Switch Product Selection Guide

NVE's GMR Switch is available in a wide range of packaging, output type, and magnetic trigger field varieties. The purpose of this selection guide is to explain the different output and packaging options, as well as to provide information on how to specify the correct part number when ordering.

All NVE GMR Switch product part numbers follow the same general form. As shown below, the first "x" in the part number specifies output type and available voltage regulator output, the next two x's specify trigger field and direction of sensitivity, and the last pair specify the package type. The following sections define these variations in detail.

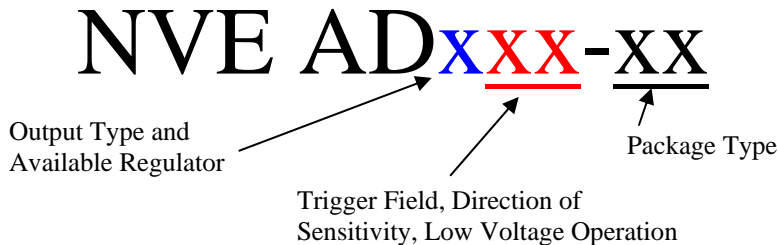

Output Type and Available Regulator

The first numeric digit of the part number NVE ADxxx-xx specifies the output type, and the availability of a regulated voltage supply on a separate pin. The following four output types are available:

- 20 mA Current Sink
- 20 mA Current Source
- Separate 20 mA Sink and Source
- Two Separate 20 mA Sinks

All outputs turn ON when the magnetic field is applied. An output that turns OFF when the magnetic field is applied is available as a custom product; please consult NVE.

Some of NVE's GMR Switches also feature a regulated supply voltage available external to the part on a separate pin. This regulator provides a 5.8V reference capable of supplying up to 3 mA of drive current. This regulated output may be used to run an LED or other low power device.

In addition to these options, NVE recently introduced a GMR Switch that has provisions for shutting down an external power transistor in case a short circuit is detected. This is useful in applications where the finished sensor assembly must be “bulletproof,” or immune to improper connection.

The following table defines the first digit in the NVE AD part number:

NVE AD x xx-xx

Number	Meaning
0	20mA Current Sink
1	20 mA Current Source
2	Separate 20mA Current Sink and 20mA Current Source
3	Two Separate 20mA Current Sinks
4	20mA Current Sink + Regulated Output Voltage
5	20 mA Current Source + Regulated Output Voltage
6	Separate 20mA Current Sink and 20mA Current Source + Regulated Output Voltage
7	Two Separate 20mA Current Sinks + Regulated Output Voltage
8	Two Separate 20mA Current Sinks + Regulated Output Voltage + Short Circuit Detection and Shut-Off
9	Separate 20mA Current Sink and 20mA Current Source + Regulated Output Voltage + Short Circuit Detection and Shut-Off

Trigger Field, Direction of Sensitivity, Low Voltage Operation

The second and third numeric digits of the part number NVE ADxxx-xx specify the magnetic trigger field and direction of sensitivity of the part. Five different magnetic trigger fields are available for the GMR Switch:

- 10 Gauss (10 Oe, 1.0 mT, 0.8 kA/m)
- 20 Gauss (20 Oe, 2.0 mT, 1.6 kA/m)
- 28 Gauss (28 Oe, 2.8 mT, 2.23 kA/m)
- 40 Gauss (40 Oe, 4.0 mT, 3.2 kA/m)
- 80 Gauss (80 Oe, 8.0 mT, 6.4 kA/m)

Other magnetic trigger field levels ranging up to 250 Gauss are available on a custom basis; please contact NVE.

In addition to defining the magnetic operate point, these two digits are used to define the direction of sensitivity and optional low voltage operation. The GMR Switch can be ordered in Standard Axis or Cross Axis directions of sensitivity; for definitions please see NVE AD Series Sensitivity Direction and Pin Configuration later in this section.

NVE also makes a GMR Switch with the on-chip voltage regulator bypassed. This limits the voltage range of the part, but allows it to operate at voltages as low as 3.0V.

The following table defines the second and third digits in the NVE AD part number:

NVE AD x xx-xx

Number	Meaning
04	20 Gauss OP, Standard Direction of Sensitivity
05	40 Gauss OP, Standard Direction of Sensitivity
06	80 Gauss OP, Standard Direction of Sensitivity
20	28 Gauss OP, Standard Direction of Sensitivity
21	20 Gauss OP, Cross Axis Direction of Sensitivity
22	40 Gauss OP, Cross Axis Direction of Sensitivity
23	80 Gauss OP, Cross Axis Direction of Sensitivity
24	28 Gauss OP, Cross Axis Direction of Sensitivity
25	10 Gauss OP, Cross Axis Direction of Sensitivity (ADH Series Only; see page 38)
81	20 Gauss OP, Cross Axis Direction of Sensitivity, Low Volt
82	40 Gauss OP, Cross Axis Direction of Sensitivity, Low Volt
83	80 Gauss OP, Cross Axis Direction of Sensitivity, Low Volt
84	28 Gauss OP, Cross Axis Direction of Sensitivity, Low Volt

Note: For parts that operate at 10 Gauss, see the following section describing the NVE ADH Series sensors.

NVE AD Series Sensitivity Direction and Pin Configuration

Pin configuration for the NVE AD Series GMR Switches is given in the following diagrams. In addition, most GMR Switch parts are available with a choice of two directions of sensitivity. “Standard” direction of sensitivity is defined as the direction parallel to the edge of the package containing the pins. “Cross-Axis” direction of

sensitivity is defined as the direction perpendicular to the edge of the package containing the pins. Pin configuration and sensitivity direction for the SOIC8 and MSOP8 packages are defined in the drawings below:

NVE AD0xx-xx through NVE AD7xx-xx, NVE ADH0xx-xx:

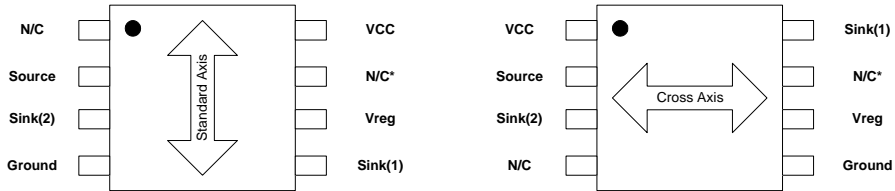

Note: In the case of a Standard Axis Part with the Vreg pin option, Sink(1) will appear at the pin labelled N/C*

NVE AD8xx-xx through NVE AD9xx-xx:



Pin configuration and sensitivity direction for the AD0xx-10 TDFN6 package are defined in the drawing below:

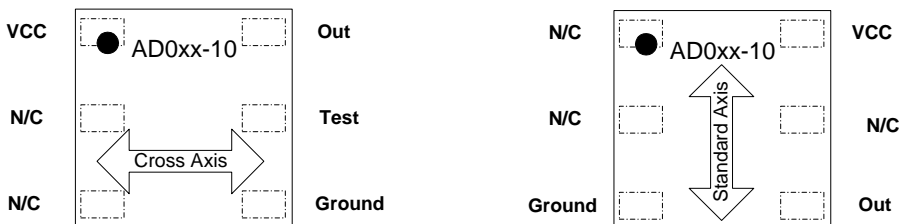

Package Type

NVE GMR Switches are available in three different packages: an SOIC 8 pin package, an MSOP 8 pin small outline package, and a TDFN 6 pin ultra-miniature package. Package drawings are shown in the Appendix.

The following table defines the last two digits in the NVE AD part number:

NVE AD x xx-xx

Number	Package Type
00	MSOP8
02	SOIC8
10 ¹	TDFN6

Note¹: At this time, the TDFN6 package is only available in AD0xx-10 configuration.

In addition to these three package types, NVE offers a custom version of the MSOP8 package for the NVE AD024-00 part. In this version, the BD012-00, all three connections are made on one side of the package, and the pins on the other side of the package are clipped off flush with the body of the package. This allows the user to position the sensing element as close to the edge of a circuit board or assembly as possible. A pinout of this package is shown below:

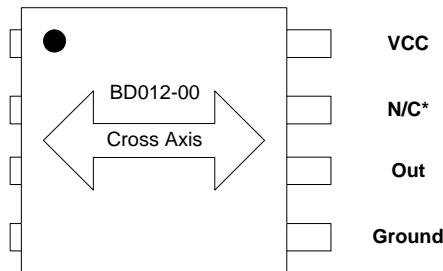

The maximum length of the clipped leads is 0.30mm, leading to an overall package length of 4.25mm, as compared to 4.90mm for the normal MSOP8 package. This part is available in tape and reel format only.

Other versions of the GMR Switch may be available in this package configuration on a special order basis. Please contact NVE for further information.

Characteristics Over Voltage and Temperature

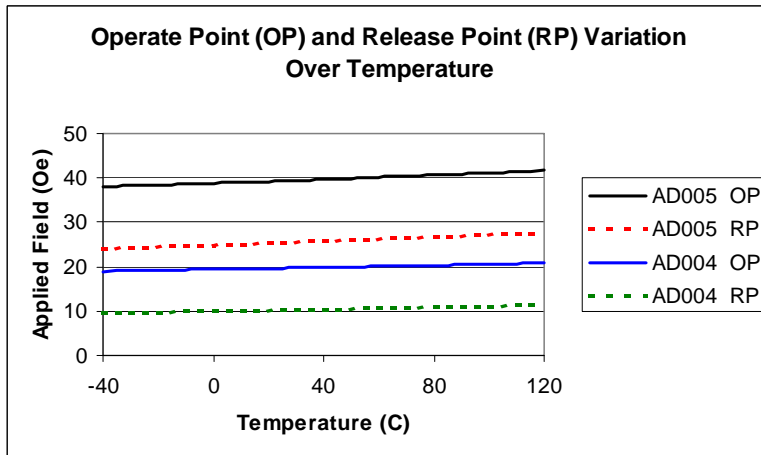
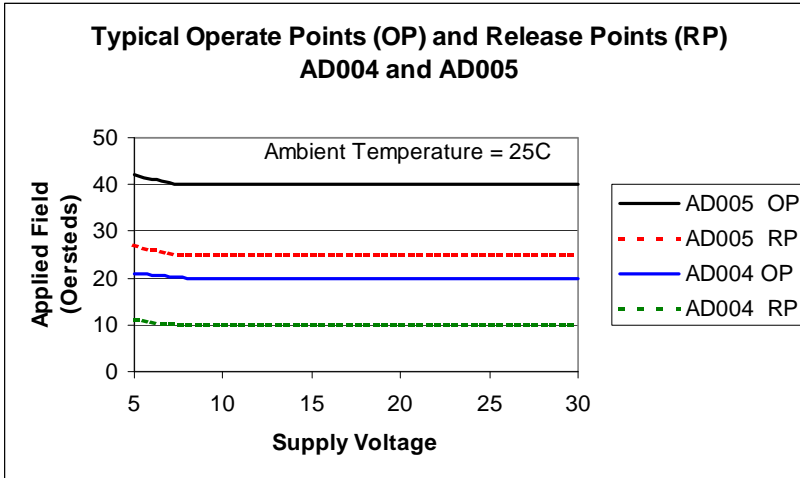

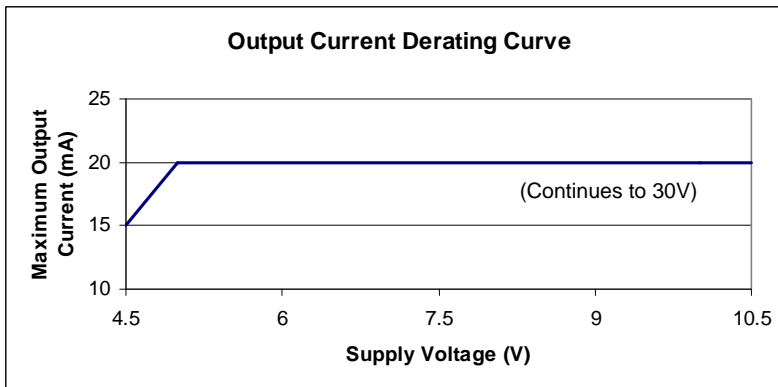
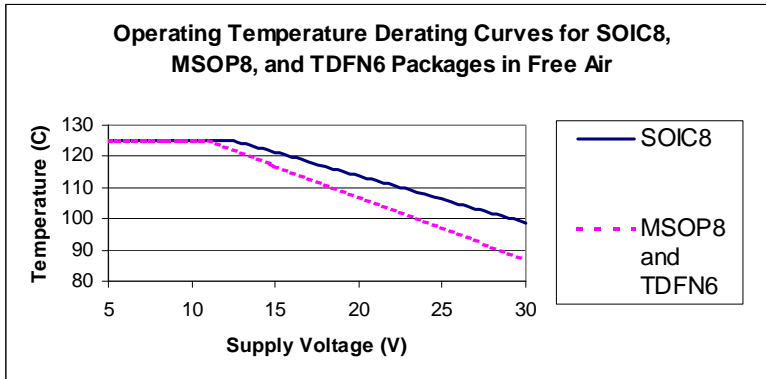

AD0xx-xx to AD7xx-xx

Features:

- ⇒ Precision Magnetic Operate Point
- ⇒ Excellent Temperature and Voltage Performance
- ⇒ Digital Outputs
- ⇒ Frequency Response 0 to 250KHz
- ⇒ Optional Voltage Regulator Output
- ⇒ Optional Low Voltage Version
- ⇒ Small, Low Profile Surface Mount Packages

Applications:

- ⇒ General Digital Position Sensing
- ⇒ Pneumatic Cylinder Position Sensing
- ⇒ Speed Sensing

Description:

The NVE AD0xx-xx to AD7xx-xx GMR Switches are digital output magnetometers that offers precision operate points over all temperature and input voltage conditions. They are available with magnetic trigger fields from 20 to 80 Gauss, and four different output configurations, making them an extremely flexible and user-friendly design.

Functional Block Diagram (NVE AD0xx-xx to NVE AD7xx-xx, Except NVE AD08x-xx):

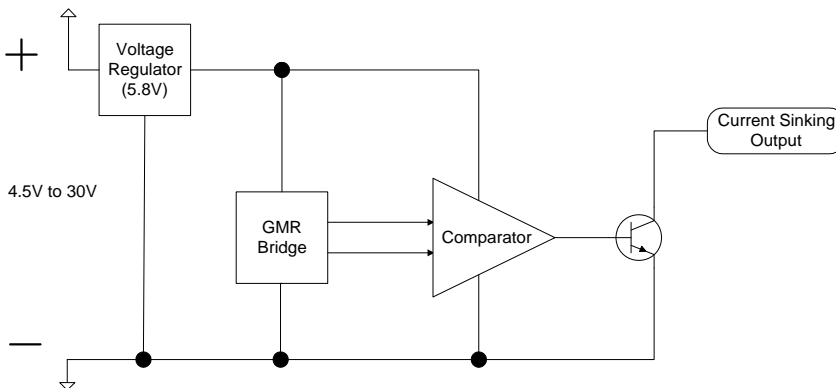

Functional Block Diagram (NVE AD08x-xx):

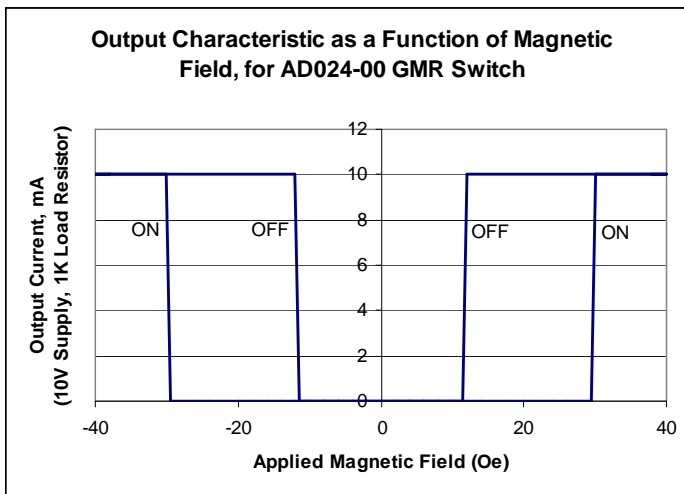
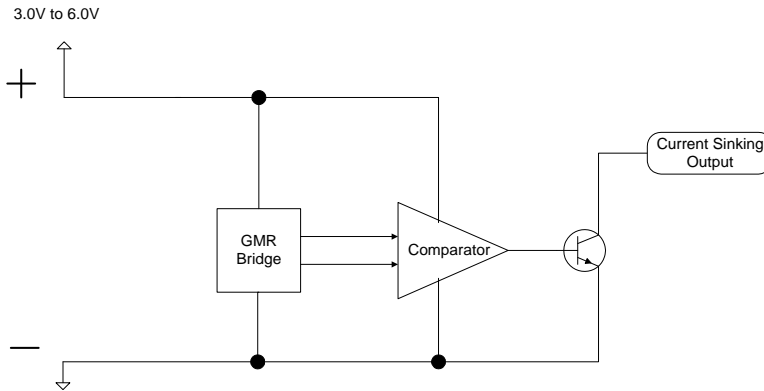

Magnetic Characteristics:

Typical Operate Point	Minimum Operate Point	Maximum Operate Point	Minimum Differential ^{1,2}	Maximum Differential ^{1,2}
20	15	25	5	14
28	21	34	5	20
40	30	50	5	25
80	60	100	5	35

Note: All Values in Oersteds (Oe); 1 Oe = 1 Gauss in Air

**Electrical Specifications (NVE AD0xx-xx to NVE AD7xx-xx,
except NVE AD08x-xx):**

Parameter	Symbol	Min	Max	Units	Test Condition
Supply Voltage ⁴	V _{CC}	4.5	30	V	Operating
Supply Current, Single Output	I _{CC}	2.5	4.5	mA	Output Off, V _{CC} =12V
Current Sinking Output ³	I _O	0	20	mA ³	Operating
Current Sourcing Output ³	I _O	0	20	mA ³	Operating
Output Leakage Current	I _{LEAK}		10	μA	Output Off, V _{CC} =12V
Sinking Output Saturation Voltage	V _{OL}		0.4	V	Output On, I _{OL} =20mA
Sourcing Output Saturation Voltage	V _{OH}		V _{CC} -2.5	V	Output On, I _{OL} =20mA
Regulated Output Voltage ⁶	V _{REG}	3.5	6.2	V	Operating
Regulated Output Current	I _{REG}		3.0	mA	Operating

Electrical Specifications (NVE AD08x-xx):

Parameter	Symbol	Min	Max	Units	Test Condition
Supply Voltage	V _{CC}	3.0	6.0	V	Operating
Supply Current, Single Output	I _{CC}	0.7	1.2	mA	Output Off, V _{CC} =3V
Supply Current, Single Output	I _{CC}	1.7	2.2	mA	Output Off, V _{CC} =6V
Current Sinking Output ²	I _O	0	20	mA ³	Operating
Output Leakage Current	I _{LEAK}		10	μA	Output Off, V _{CC} =5V
Sinking Output Saturation Voltage	V _{OL}		0.4	V	Output On, I _{OL} =20mA

**Absolute Maximum Ratings (NVE AD0xx-xx to NVE AD7xx-xx,
except NVE AD08x-xx):**

Parameter	Symbol	Min	Max	Units
Supply Voltage	V _{CC}		33	V
Reverse Battery Voltage	V _{RBP}		-33	V
Current Sinking Output Off Voltage			33	V
Current Sourcing Output Off Voltage			0	V
Current Sinking Reverse Output Voltage			-0.5	V
Current Sourcing Reverse Output Voltage			-0.5	V
Continuous Output Current	I _O		24	mA
Operating Temperature Range ⁴	T _A	-40	125	°C
Storage Temperature Range	T _S	-65	150	°C
Magnetic Field ⁵	H		None	Oe

Absolute Maximum Ratings (NVE AD08x-xx):

Parameter	Symbol	Min	Max	Units
Supply Voltage	V_{CC}		7	V
Reverse Battery Voltage	V_{RBP}		-0.5	V
Current Sinking Output Off Voltage			33	V
Current Sinking Reverse Output Voltage			-0.5	V
Continuous Output Current	I_o		24	mA
Operating Temperature Range ^a	T_A	-40	125	°C
Storage Temperature Range	T_S	-65	150	°C
Magnetic Field ^b	H		None	Oe

Notes:

1. Differential = Operate Point – Release Point
2. Minimum Release Point for AD0xx-xx to AD7xx-xx, except AD08x-xx, = 5 Oe. Minimum Release Point for AD08x-xx = 3.5 Oe.
3. Output current must be limited by a series resistor. Exceeding absolute maximum continuous output current ratings will result in damage to the part. See the figure in the GMR Switch Product Selection Guide for an output current derating curve.
4. Thermal power dissipation for the packages used by NVE is 240°C/Watt for the SOIC8 package, and 320°C/Watt for the MSOP8 and TDFN6 packages. See the Figure on Ambient Temperature vs. Supply Voltage for derating information. Heat sinking the parts by attaching them to a PCB improves temperature performance.
5. There is no maximum magnetic field that will cause damage to the device.
6. If $V_{CC} > 6.6V$, $V_{REG} = 5.8V$. If $V_{CC} < 6.6V$, $V_{REG} = V_{CC} - 0.9V$.

AD8xx-xx to AD9xx-xx

Features:

- ⇒ Short Circuit Detection and Shutoff of External Power Transistor
- ⇒ Precision Magnetic Operate Point
- ⇒ Excellent Temperature and Voltage Performance
- ⇒ Digital Outputs
- ⇒ Frequency Response 0 to 250KHz
- ⇒ Small, Low Profile Surface Mount Packages

Applications:

- ⇒ General Digital Position Sensing
- ⇒ Pneumatic Cylinder Position Sensing
- ⇒ Speed Sensing

Description:

NVE AD8xx and AD9xx GMR Switches are designed specifically for use with an external high current output transistor in industrial control environments. These parts provide the same precise magnetic performance NVE’s GMR Switch is known for, with the additional functionality of short circuit protection (SCP) for the output stage of the circuit. The protection circuit is designed to shut off the output stage when a short circuit condition exists; after a time interval specified by the user, the circuit turns back on. If the short circuit condition still exists, the output stage is again shut off and the cycle repeats. The use of this sensor, along with external reverse battery protection and overvoltage protection, results in a “bulletproof” sensor assembly. A functional block diagram of this sensor is shown below:

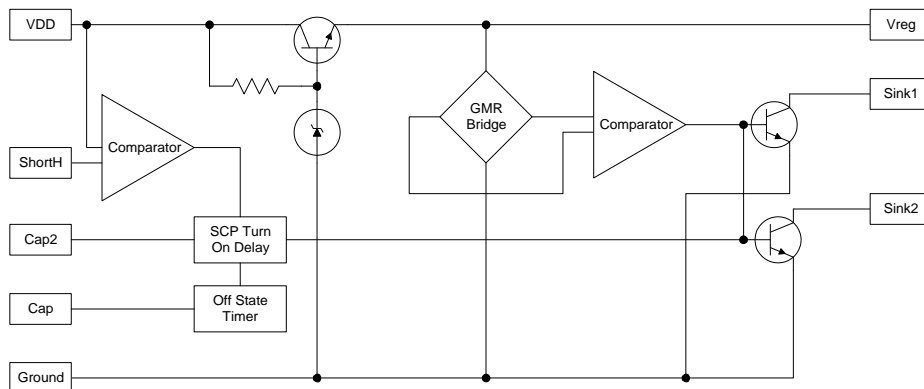

These digital sensors with SCP are available for use with current sinking or current sourcing outputs, in a range of magnetic field operate points. They are provided in an

MSOP8 package, with the cross-axis direction of sensitivity. An LED driver to indicate the presence of the magnetic field is also standard on these products. An SOIC8 package and standard axis sensitivity are available on a special order basis.

Typical Circuit Configuration:

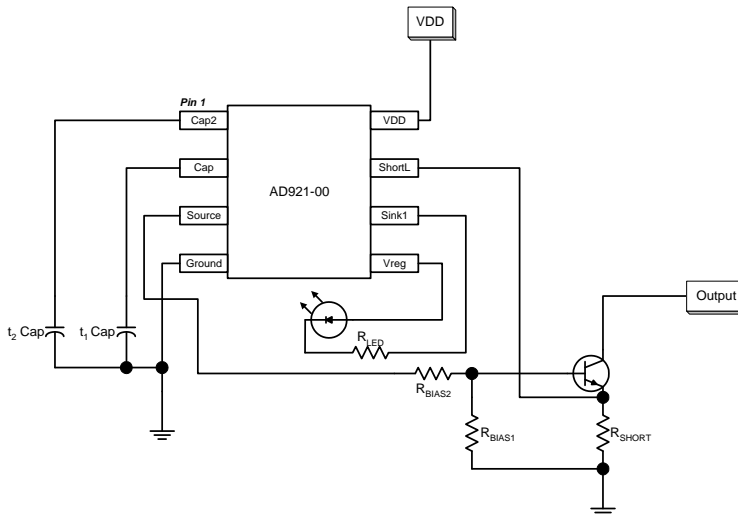
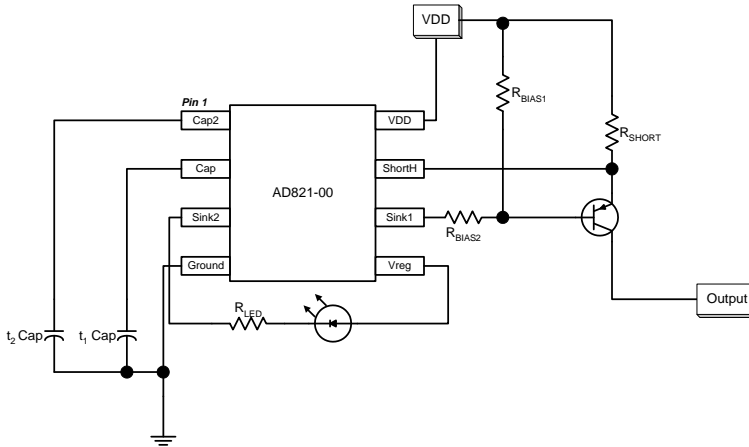

Output Transistor Current in Short Circuit mode:

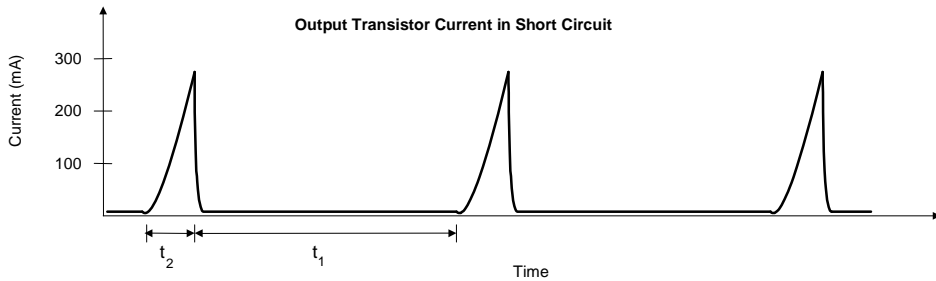

Notes:

1. The t_2 Cap is used to delay the startup of the SCP circuitry, in order to avoid triggering the SCP circuitry on normal startup transients: see t_2 on the graph above. Typical value is 16V, 0.001 μ F, for a 35 μ s delay.
2. The t_1 Cap is used to set the "Off" time of the SCP circuitry; see t_1 on the graph above. Typical value is 16V, 0.01 μ F, for a 15ms Off time.
3. The voltage across R_{SHORT} is monitored by the IC; if this voltage exceeds 145mV (typical), the SCP circuitry is activated. Typical value of R_{SHORT} is 0.47 Ohms, 1/16 watt. This will result in SCP circuitry turning on at about 300mA of output current.
4. R_{BIAS1} and R_{BIAS2} are used to bias the output transistor. Typical values for R_{BIAS1} and R_{BIAS2} are 16K and 3K, respectively, to supply 1mA drive to the output transistor.
5. R_{LED} is sized for whatever LED current is required by the user; maximum of 3 mA.

Magnetic Characteristics:

Typical Operate Point	Minimum Operate Point	Maximum Operate Point	Minimum Differential ^{1,2}	Maximum Differential ^{1,2}
20	15	25	5	14
28	21	32.5	5	15
40	30	50	5	25
80	60	100	5	35

Note: All Values in Oersteds (Oe); 1 Oe = 1 Gauss in Air

Electrical Specifications:

Parameter	Symbol	Min	Max	Units	Test Condition
Supply Voltage ⁴	V _{CC}	4.5	30	V	Operating
Supply Current	I _{CC}	1.75	3.5	mA	Output Off, V _{CC} =12V
Current Sinking Output ²	I _O	0	2.0	mA ³	Operating
Current Sourcing Output ²	I _O	0	2.0	mA ³	Operating
Output Leakage Current	I _{LEAK}		10	μA	Output Off, V _{CC} =12V
Sinking Output Saturation Voltage	V _{OL}		0.4	V	Output On, I _{OL} =2mA
Sourcing Output Saturation Voltage	V _{OH}		V _{CC} -2.0	V	Output On, I _{OL} =2mA
Regulated Output Voltage ⁶	V _{REG}	3.5	6.0	V	Operating
Regulated Output Current	I _{REG}		3.0	mA	Operating
Short High Voltage	ShortH	0.12	0.17	V	Output On
Short Low Voltage	ShortL	0.12	0.17	V	Output On

Absolute Maximum Ratings:

Parameter	Symbol	Min	Max	Units
Supply Voltage	V _{CC}		33	V
Reverse Battery Voltage	V _{RBP}		-0.5	V
Current Sinking Output Off Voltage			33	V
Current Sourcing Output Off Voltage			0	V
Current Sinking Reverse Output Voltage			-0.5	V
Current Sourcing Reverse Output Voltage			-0.5	V
Continuous Output Current	I _O		5	mA
Operating Temperature Range ⁴	T _A	-40	125	°C
Storage Temperature Range	T _S	-65	135	°C
Magnetic Field ⁵	H		None	Oe

Notes:

- Differential = Operate Point – Release Point
- Minimum Release Point for AD8xx-xx to AD9xx-xx = 5 Oe.
- Output current must be limited by a series resistor. Exceeding absolute maximum continuous output current ratings will result in damage to the part.
- Thermal power dissipation for the packages used by NVE is 240°C/Watt for the SOIC8 package, and 320°C/Watt for the MSOP8 and TDFN6 packages. See the Figure on Ambient Temperature vs. Supply Voltage for derating information. Heat sinking the parts by attaching them to a PCB improves temperature performance.
- There is no maximum magnetic field that will cause damage to the device.
- If V_{CC}>6.6V, V_{REG}=5.8V. If V_{CC}<6.6V, V_{REG}= V_{CC} -0.9V.

ADH0xx-xx

Features:

- ⇒ Precision Low Field Magnetic Operate Point
- ⇒ Excellent Temperature and Voltage Performance
- ⇒ Digital Output
- ⇒ Frequency Response 0 to 250KHz
- ⇒ Small, Low Profile Surface Mount Packages

Applications:

- ⇒ Low Field Digital Position Sensing
- ⇒ Pneumatic Cylinder Position Sensing
- ⇒ Speed Sensing

Description:

The NVE ADH0xx Series GMR Switch uses NVE's high sensitivity, high temperature GMR material to provide a very low magnetic field operate point. It offers the same precision operate points over all temperature and input voltage conditions as our other GMR Switch products. It is available in standard form as the NVE ADH025-00 with a magnetic trigger field of 10 Gauss, a current sinking output, and a cross axis configuration. Custom versions with trigger fields ranging from 6 to 40 Gauss, and different output options and sensitivity directions could be manufactured for specific customer requirements; please contact NVE for details.

Note: Functional Block Diagram for the NVE ADH0xx-xx Series sensors is the same as for the NVE AD0xx-xx sensors.

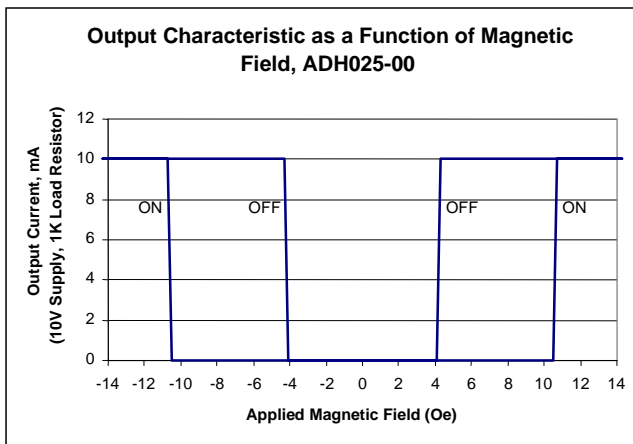

Magnetic Characteristics, NVE ADH025-00:

Typical Operate Point	Minimum Operate Point	Maximum Operate Point	Minimum Differential ¹	Maximum Differential ¹
10	8	12	3.5	10

Note: All Values in Oersteds (Oe); 1 Oe = 1 Gauss in Air

Electrical Specifications, NVE ADH0xx-xx:

Parameter	Symbol	Min	Max	Units	Test Condition
Supply Voltage ⁴	V _{CC}	4.5	30	V	Operating
Supply Current, Single Output	I _{CC}	3.0	6.0	mA	Output Off, V _{CC} =12V
Current Sinking Output ³	I _O	0	20	mA ³	Operating
Output Leakage Current	I _{LEAK}		10	μA	Output Off, V _{CC} =12V
Sinking Output Saturation Voltage	V _{OL}		0.4	V	Output On, I _{OL} =20mA

Absolute Maximum Ratings:

Parameter	Symbol	Min	Max	Units
Supply Voltage	V _{CC}		33	V
Reverse Battery Voltage	V _{RBP}		-33	V
Current Sinking Output Off Voltage			33	V
Current Sourcing Output Off Voltage			0	V
Current Sinking Reverse Output Voltage			-0.5	V
Current Sourcing Reverse Output Voltage			-0.5	V
Continuous Output Current	I _O		24	mA
Operating Temperature Range ⁴	T _A	-40	125	°C
Storage Temperature Range	T _S	-65	150	°C
Magnetic Field ⁵	H		None	Oe

Notes:

- Differential = Operate Point – Release Point
- Minimum Release Point for ADH0xx-xx = 2.0 Oe.
- Output current must be limited by a series resistor. Exceeding absolute maximum continuous output current ratings will result in damage to the part. See the figure in the GMR Switch Product Selection Guide for an output current derating curve.
- Thermal power dissipation for the packages used by NVE is 240°C/Watt for the SOIC8 package, and 320°C/Watt for the MSOP8 and TDFN6 packages. See the Figure on Ambient Temperature vs. Supply Voltage for derating information. Heat sinking the parts by attaching them to a PCB improves temperature performance.
- There is no maximum magnetic field that will cause damage to the device.