

RFID EVALUATION KIT



sames

EK7110DKEY

OVERVIEW

The EK7110DKEY evaluation kit is designed to demonstrate the functionality of the SAMES SA7110 64-bit read only transponder using the SAMES key ring tag and the Intersoft* reader.

The EK7110DKEY evaluation kit performs all the functions necessary for a RFID reading station. The reader continuously powers, reads and decodes transponders that are within its reading range. An RF magnetic field, generated by the reader, powers the transponder tag when it passes within the range of the reader's antenna. The data transmitted by the tag is demodulated and decoded by the reader. The data is then sent as a packet using a two-wire serial RS232 interface. While the tag remains within the reading range it will be

continuously powered and the reader will continuously transmit its data.

The kit includes:

- Passive read-only RFID key-ring tags.
- A fully functional reader with antenna.
- Windows Software to read and display the RFID tag numbers on a PC (SA7110Demo.exe)

REQUIREMENTS

Power source 9-12 VDC regulated, 60mA.
PC computer with an available serial port.
Db9MaletoDb9Female serial cable.
MS Windows (98, 2000, XP)

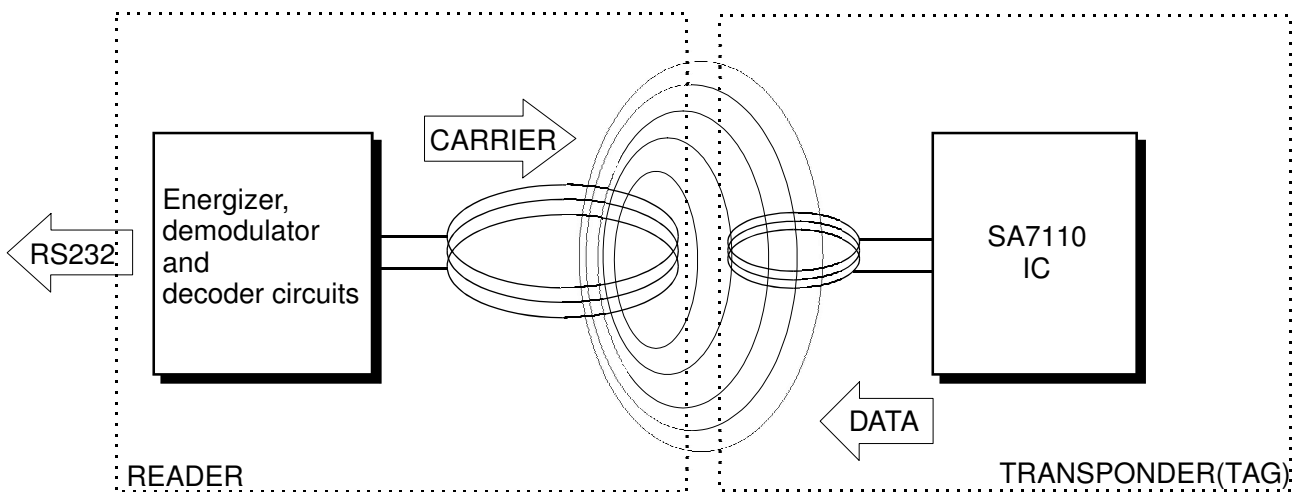



EK7110DKEY

CONNECTION

The RFID reader comes configured for 9600 baud, 8 data bits, parity none, stop bit 1 - ready to connect to the serial port of a PC via a DB9 serial cable.

The reader has two connectors: a female DB9, and a DC power connector. The female DB9 provides the RS232 signal output from the reader. Pin 2 is the transmit signal output (TXD). It should be connected to the receive signal input (RXD) of the PC. Pin 5 is the common ground reference signal

and should be connected to the common ground of the computer.

The DC power jack is used to power the reader. The center pin of the jack is connected to the positive terminal (+) of a 9 to 12 VDC (60mA max) power supply. The outer conductor is connected to the negative side (-) of the power supply. You may also use the 9 volt battery connector supplied. Any 9 volt battery (alkaline) can be used.

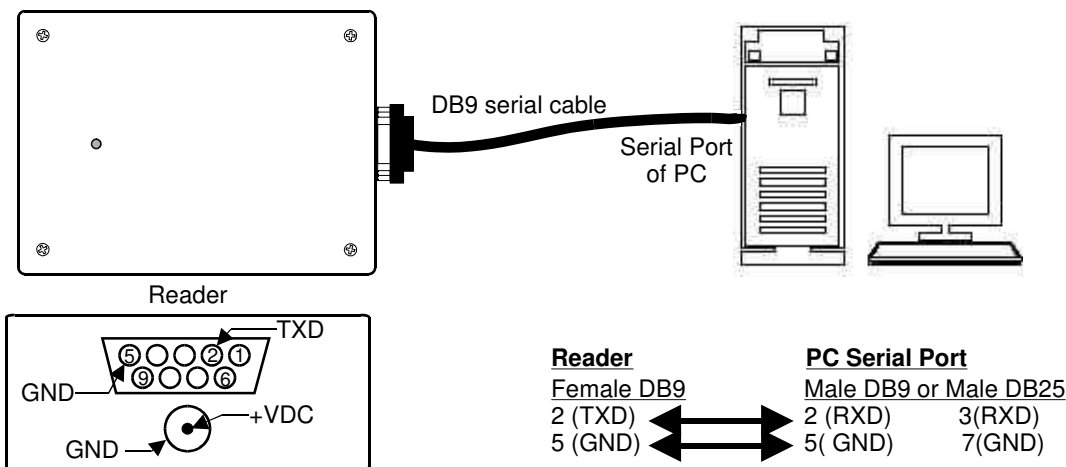

DATA TRANSMISSION

When the reader detects the RFID tag, an ASCII data stream is transmitted using a 2 wire (txd and gnd) RS232 interface. This data packet is comprised of 1 start byte, 10 data bytes in ASCII, 2 checksum bytes and 1 stop byte.

The start byte is always a ":" (58d, 3Ah). The 10 data bytes are an ASCII representation of the ten hexadecimal serial code digits (5 numbers) stored in the tag that has just been read. The checksum is two bytes long. The stop byte is always an ASCII "carriage return" (13d, 0Dh).

3A	10 ASCII Hex Data Characters	2 ASCII Hex Checksum Characters	0D
Start byte	10 bytes	2 bytes	Stop byte

As an example when a tag serial 01 AF 36 BE D2 hexadecimal is decoded the following 14 byte packet would then be transmitted (shown in hexadecimal):

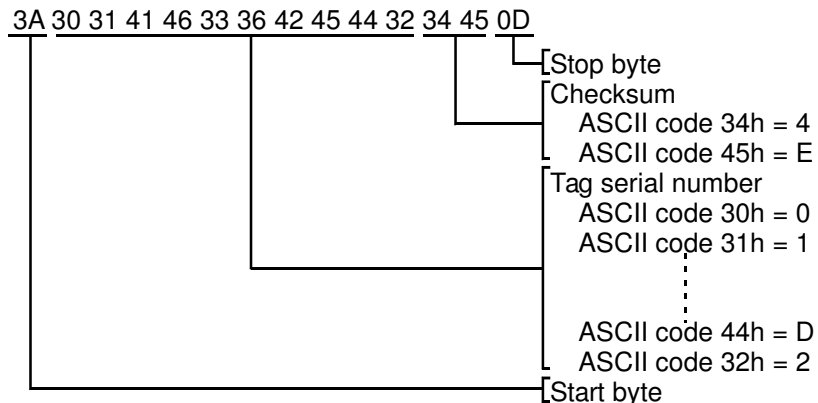



EK7110DKEY

The data packet is sent every time a tag is detected. If the tag remains in the reading field, its data will be sent continuously.

CHECKSUM CALCULATION

The reader does a checksum calculation which is an ASCII representation of the 8 bit sum of the 10 data bytes sent. From the example above the checksum value 34 45 (4E) is a result of 30h+31h+41h+46h+33h+36h+42h+45h+44h+32h

SOFTWARE INSTALLATION

There is no installation program. The software may be started directly from the CD. It should be preferably copied to a directory on your hard drive and executed from there.

After properly connecting the reader (power and serial port) start the SA7110 demonstration program (SA7110Demo.exe). The program will automatically detect the PC's comm ports. Select the port connected to the reader and press the "Open Port" button. When a tag is passed over the top of the reader, the readers green LED should flash and the decoded tag number as well as the checksum will appear in the "Reader data" window. The tag number as well as the time and date will also be logged in the "Logger" window. If the tag remains in the reading field, the data will be continuously displayed in the "Reader data" window but will only be logged once every 3 seconds in the "Logger" window.

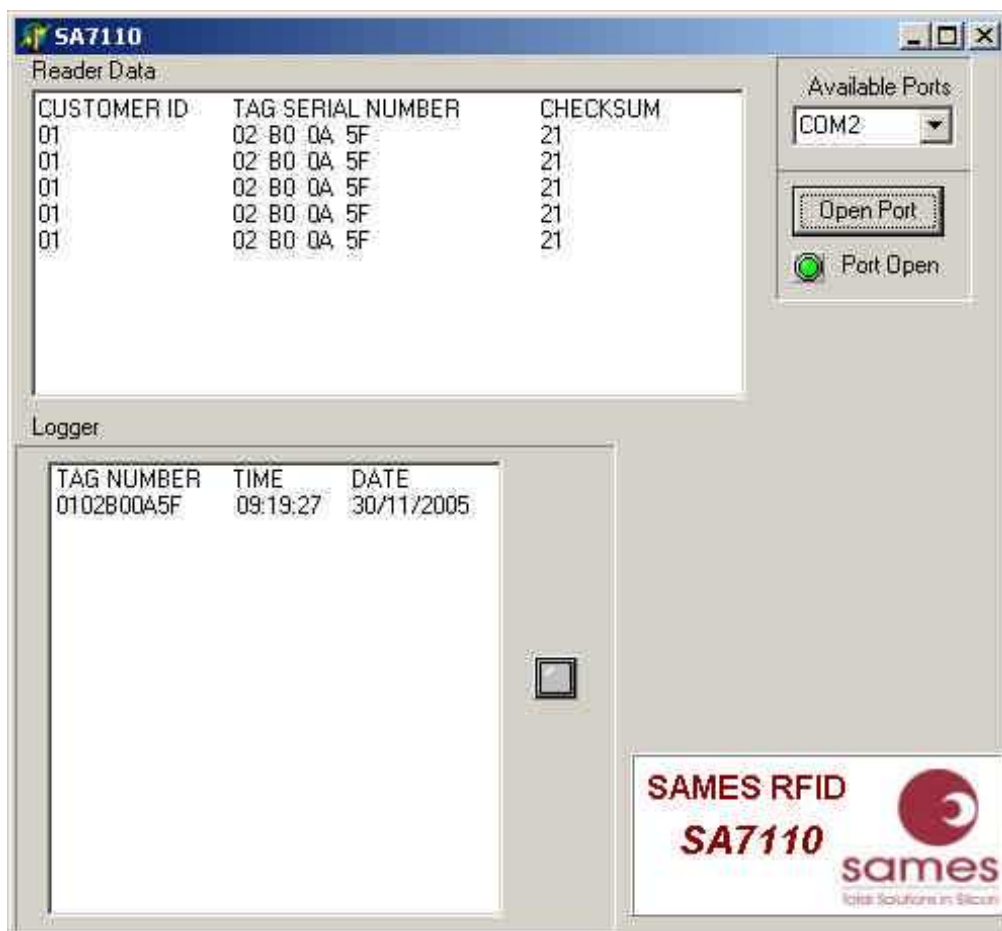

RFID EVALUATION KIT



sames

EK7110DKEY

DISCLAIMER:

The information contained in this document is confidential and proprietary to South African Micro-Electronic Systems (Pty) Ltd ("SAMES") and may not be copied or disclosed to a third party, in whole or in part, without the express written consent of SAMES. The information contained herein is current as of the date of publication; however, delivery of this document shall not under any circumstances create any implication that the information contained herein is correct as of any time subsequent to such date. SAMES does not undertake to inform any recipient of this document of any changes in the information contained herein, and SAMES expressly reserves the right to make changes in such information, without notification, even if such changes would render information contained herein inaccurate or incomplete. SAMES makes no representation or warranty that any circuit designed by reference to the information contained herein, will function without errors and as intended by the designer.

Any sales or technical questions may be posted to our e-mail address below:
id_security@sames.co.za

For the latest updates on datasheets, please visit our web site:
<http://www.sames.co.za>

SOUTH AFRICAN MICRO-ELECTRONIC SYSTEMS (PTY) LTD

Tel: (012) 333-6021
Tel: Int +27 12 333-6021
Fax: (012) 333-8071
Fax: Int +27 12 333-8071

**P O BOX 15888
33 ELAND STREET
LYNN EAST 0039
REPUBLIC OF SOUTH AFRICA**

**33 ELAND STREET
KOEDOESPOORT INDUSTRIAL AREA
PRETORIA
REPUBLIC OF SOUTH AFRICA**