

---

**PCM FRAME ALIGNER**

---

**FEATURES**

- Frame alignment/synthesis for PCM30 double frame and CRC-multiframe format.
- Meets CCITT Rec.G704
- Interface to route selectable between HDB3 and fibre optical
- HDB3 outputs switchable between fully banded and half banded format
- Error checking via CRC4 procedure
- Insertion and extraction of alarms and facility signals
- Selectable system - clock (4096 kHz/ 8192 kHz)
- Selectable Interface mode (2048/4096 kBit/s) to system internal highway
- Programmable offsets for receive and transmit data
- Two frame receive buffer for receive route clock wander and jitter compensation
- Slip detection and direction indication
- Extended HDB3 error detection
- Error counters for code errors (switchable to "S<sub>z</sub>zeros counter"), frame errors and CRC4 errors
- Sub-multiframe assigned CRC Error indication with possibility of automatic insertion in Si-bit position of outgoing multiframe.
- Simplified data transfer between SA9101 and controller, supported by data stacks for receive and transmit signalling data, selectable interrupt-sources and DMA facilities.
- Double frame marker for serial data extraction support
- Repeated transmission of signalling data, if not updated.
- Three transparent modes for timeslot 0 in transmit direction
- Transparent mode for receive direction
- HDB3 error indication
- Idle channel data insertion selectable for any timeslot
- Channel loopback capabilities, test and diagnostic capabilities
- Parity checks

**DESCRIPTION:**

The SA9101 (Frame Alignment unit for PCM30 Systems) is a C-MOS device which implements the interface to PCM30 Transmission Systems.

In the receive direction, the device performs HDB3 decoding, Frame alignment (selectable between doubleframe and CRC-Multiframe) and extraction of signalling data.

Wander absorption between the PCM carrier and the system internal highway is performed using an internal 2 frame memory. The incoming data stream is monitored

**Description (Cont.)**

status and error conditions are reported through the  $\mu$ P interface. In the transmit direction, Frame (and Multiframe) alignment, signalling data insertion and HDB3 coding is performed.

If Multiframe format is enabled, CRC4 extraction and checking are carried out in the receive direction and CRC4 data is inserted in the transmit direction.

Stacks for transmit and receive signalling data with DMA capability as well as maskable interrupt sources simplify interfacing to microcontrollers.

Alarm simulation capabilities and selectable channel-loopback, support system diagnostics.

Different transparent modes for timeslot 0 in transmit direction simplify system test and data transmission through the system.

Advanced algorithms for synchronisation of doubleframe and CRC4 multiframe format data, and monitoring of frame and doubleframe formats minimise loss of data.

Control Registers allow different control settings through the  $\mu$ P interface.

Advanced C-MOS Technology ensures low power consumption and high reliability.

The device is upwards compatible with the Siemens ACFA (PEB 2035 V4.1) in PCM30

**PIN CONNECTIONS**

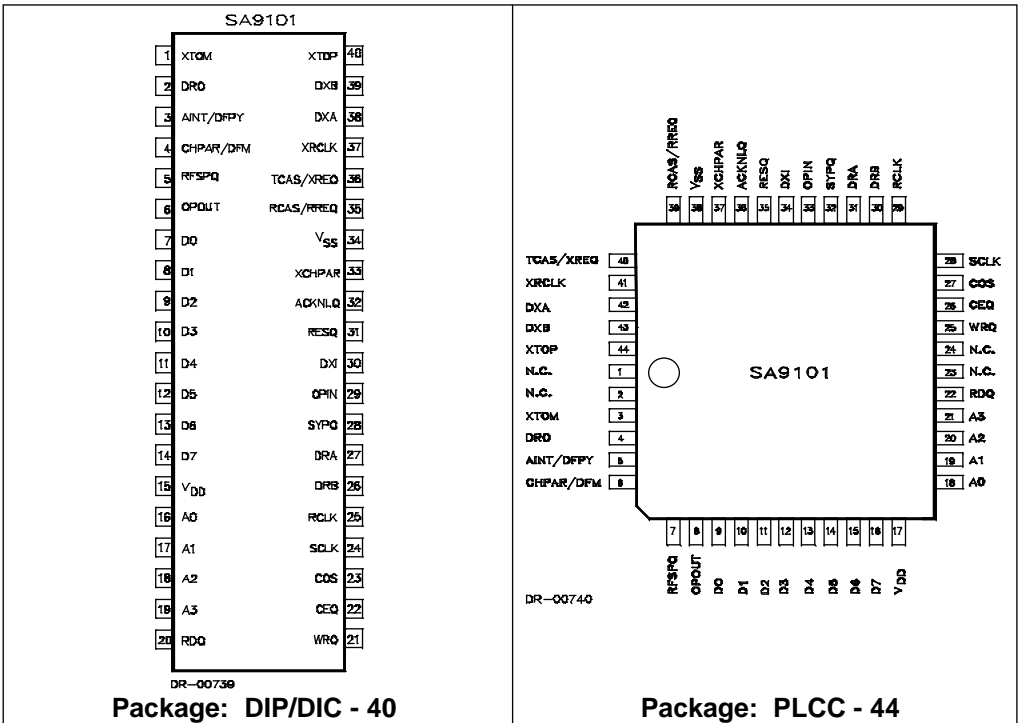

### Block Diagram

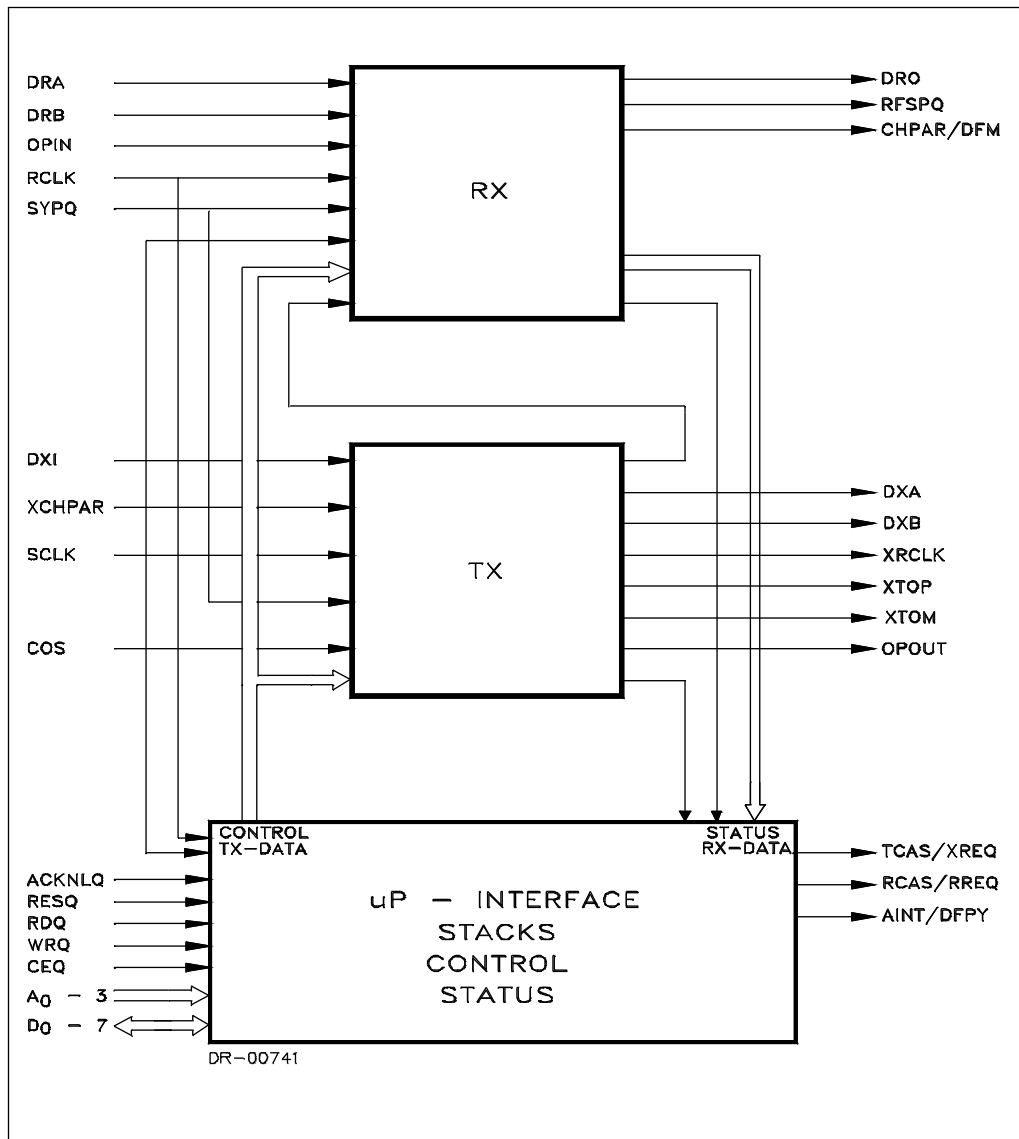

**ELECTRICAL CHARACTERISTICS****Absolute Maximum Ratings\***

Parameters	Symbol	Min	Max	Unit
Supply Voltage	$V_{DD} - V_{SS}$	-0.3	6	V
Voltage on any I/O pin	$V_I/V_O$	-0.3	$V_{DD}+0.3$	V
Current on any I/O pin	$I_I/I_O$		20	mA
Storage Temperature	$T_{STG}$	-55	+125	°C
Operating Temperature	$T_{OP}$	-10	+70	°C
Package Power Dissipation	$P_D$		1000	mW

\*Stress above those listed under "Absolute Maximum Ratings" may cause permanent damage to the device. This is a stress rating only. Functional operation of the device at these or any other condition above those indicated in the operational sections of this specification, is not implied. Exposure to Absolute Maximum Ratings for extended periods may affect device reliability.

**DC Operational Characteristics**

$V_{DD} = 5V$ ,  $T = 10^{\circ}C..+70^{\circ}C$

Parameter	Symbol	Limit Values		Unit	Remarks
		Min.	Max.		
Supply Voltage	$V_{DD}-V_{SS}$	4.5	5.5	V	
Supply Current (dynamic)	$I_{DD}$		100	mA	
Standby Current	$I_{DDS}$		100	$\mu A$	
Inputs					
High Voltage	$V_{IH}$	2.4		V	
Low Voltage	$V_{IL}$		0.8	V	
Leakage Current	$I_{LEAK}$	-5	5	$\mu A$	$V_I=0..V_{DD}$
Input ACKNQ					
Pullup Current	$-I_{PUP}$	10	30	$\mu A$	$V_I=0$
Outputs					
High Voltage	$V_{OH}$	2.8		V	$I_{OH}=-1mA$
Low Voltage	$V_{OL}$		0.4	V	$I_{OL}=2mA$
Bidirects					
Input High Voltage	$V_{IH}$	2.4		V	
Input Low Voltage	$V_{IL}$		0.8	V	
Tristate Current	$I_{LEAK}$	-10	10	$\mu A$	$V_I=0..V_{DD}$
Output High Voltage	$V_{OH}$	2.8		V	$I_{OH}=-1mA$
Output Low Voltage	$V_{OL}$		0.4	V	$I_{OL}=2mA$

**Operational Characteristics**

$T_A = 25^{\circ}C$ ;  $V_{DD} = 5V \pm 5\%$ ;  $V_{SS} = 0V$

Parameter	Symbol	Limit Values		Unit
		Min.	Max.	
Input capacitance	$C_{IN}$		10	pF
Output capacitance	$C_{OUT}$		15	pF
I/O	$C_{IO}$		20	pF



## PIN DESCRIPTION

Pin Name	Direction	Pin No.		Description
		DIL	PLCC	
AINT/DFPY	O	3	5	Alarm interrupt/Double Frame Parity
ACKNLQ	I	32	36	DMA Acknowledge
A[3-0]	I	19-16	21-18	Address Bus
CEQ	I	22	26	Chip Enable
CHPAR/DFM	O	4	6	Receive Channel Parity/ Double Frame Marker
COS	I	23	27	Carrier out of Service
DRA	I	27	31	Receive Data in Plus
DRB	I	26	30	Receive Data in Minus
DRO	O	2	4	Receive Data Out
DXA	O	38	42	Transmit Data Out Plus
DXB	O	39	43	Transmit Data Out Minus
DXI	I	30	34	Transmit Data In
D[7-0]	B	14-7	16-9	Data Bus
OPIN	I	29	33	Receive Optical Interface Data
OPOUT	O	6	8	Transmit Optical Interface Data
RCAS/RREQ	O	35	39	Receive TS16 Signal/Receive DMA Interrupt Request
RCLK	I	25	29	Receive Route Clock
RDQ	I	20	22	Read Enable
RESQ	I	31	35	Reset
RFSPQ	O	5	7	Receive Frame Synchronisation Pulse
SCLK	I	24	28	System Clock
SYPQ	I	28	32	Synchronisation Pulse
TCAS/XREQ	O	36	40	Transmit TS16 Signal/Transmit DMA Interrupt Request
V <sub>DD</sub>	S	15	17	+5V Supply
V <sub>SS</sub>	S	34	38	0V Ground
WRQ	I	21	25	Write Enable
XCHPAR	O	33	37	Transmit Channel Parity
XRCLK	O	37	41	Transmit Route Clock
XTOM	O	1	3	Test Data Output Minus
XTOP	O	40	44	Test Data Output Plus

## DESCRIPTION OF INTERFACES

### Fibre Optical Interface

The fibre optical interface is enabled via the microprocessor interface.

Signal	Pin	Input/Output/Bidirect	Function
OPIN	29	I	Optical Fibre In Unipolar Input Signal at 2048 kbps Input polarity sense is programmable via CR8B3. Latching of data is performed with the falling edge of RCLK if optical interface is selected via CR1B2. (See Fig. 6 Line Interface Timing.)
OPOUT	6	O	Optical Fibre Out Unipolar Output Signal at 2048 kbps The output's active polarity is programmable via CR6B7. Data is clocked out on the rising edge of XRCLK. Data duty cycle is 100%. (See Fig. 6 Line Interface Timing.)
RCLK	25	I	Route Clock This clock, derived from the incoming data by the line interface circuit (eg. IPAT (PEB2235)), is necessary for clocking received data into the SA9101.
XRCLK	37	O	Transmit Route Clock This 2048kHz clock is generated from the Station Clock, SCLK. (See Fig. 5 System Interface Timing and Fig. 6 Line Interface Timing.)

### PCM30 Interface

Signal	Pin	Input/Output/Bidirect	Function
DRA	27,	I	Data Receive +/-
DRB	26	I	HDB3 coded PCM Signal
DXA	38,	O	Data transmit +/-
DXB	39	O	HDB3 coded PCM Signal
RCLK	25	I	Route Clock $f = 2.048$ MHz
XRCLK	37	O	Transmit route clock



## Clock Generator

Signal	Pin	Input/Output/Bidirect	Function
SCLK	24	I	System Clock $f=4,096 \text{ MHz}/8,192\text{MHz}$
RFSPQ	5	O	Receive Frame Pulse Frequency: 8 kHz Duration: 488 ns If loss of synchronisation, the line frame pulse is inhibited
SYPQ	28	I	Synchronous Pulse Defines start of frame for System internal data, together with the programmed offset values of transmit and receive counter. Pulse width: >244 ns Period: Multiples of 125 $\mu$ s

## DIU Controller

Signal	Pin	Input/Output/Bidirect	Function
D0 - D7	7 - 14	B	Bidirectional 8 bit data-bus
A0 - A3	16 - 19	I	Address lines for SA9101 internal registers
CEQ	22	I	Chip enable input
WRQ	21	I	Write enable input
RDQ	20	I	Read enable input
COS	23	I	Carrier out of service input. SA9101 sends AIS to PCM30 interface if input is at "1"
XREQ	36	O	Transmit DMA interrupt request
RREQ	37	O	Receive DMA interrupt request
AINT	3	O	Alarm interrupt request
ACKNLQ	32	I	DMA Acknowledge (Active Low)  (Not used when CR6B6 = 0. If not used then pin must be fixed to $V_{DD}$ .) If access to internal TS16 signalling stacks is enabled this input acts as an "access enable" to the internal stacks (CRAB0-7 for $T_x$ and SR7B0-7 for $R_x$ ) in conjunction with a read/write command without the need of generating the chip enable signal at CEQ. In this case it is to be connected to the acknowledge output of the DMA controller.

## System Internal Highway

Signal	Pin	Input/Output/Bidirect	Function
DRO	2	O	Data Receive Out
DXI	30	I	Data Transmit In

Timeslot channels 0 - 31 to/from PCM30 interface.

Bit rate 2048 kbit/s or 4096 kbit/s selectable via microprocessor interface.

## CAS Processing

Signal	Pin	Input/Output/Bidirect	Function
DRO	2	O	Data Receive Out
DXI	30	I	Data Transmit In
RCAS	35	O	Receive CAS, active high marks reception of channel 16
TCAS	36	O	Transmit CAS, active high marks transmission of channel 16

## Test/Supervision

Signal	Pin	I nput/Output/Bidirect	Function
CHPAR	4	O	Receive Channel parity Appears according to the related channel (timeslot)
DFPAR	3	O	Doubleframe Parity During a current double-frame, the parity of the previous double-frame appears on DFPAR
XTOP XTOM	40, 1	O O	HDB3-coded PCM (+), PCM (-) signal for HDB3 diagnostic loop
RESQ	31	I	Reset (Output Disable) Asynchronous reset signal (active low), resets the internal circuit and switches all outputs to high impedance state - must be held low for minimum of 2µs
XCHPAR	33	I	Transmit channel parity



## FUNCTIONAL DESCRIPTION

### Receive path

#### Receive Link Interface

For data input, two different data types, with selectable input active polarity sense, are supported:

- Dual rail data (PCM[+], PCM[-]) at ports DRA, DRB received from a Line Interface Unit.
- Unipolar data at port OPIN (PCM 30) received from a fibre optical Interface.

Latching of data is carried out using the falling edge of the Receive route Clock (RCLK, 2048 kHz) recovered from the PCM receive data stream. Dual rail data is subsequently converted into a single rail, unipolar bit stream. The HDB3 line code is used along with Double Violation Detection or Extended Code Violation Detection (selectable). These errors increment the Code Violation Counter.

When using the unipolar input mode, the decoder is by-passed and no code violation will be detected.

Additionally, the receive Link Interface comprises the alarm detection for AIS (Alarm Indication Signal: unframed bit stream with constant logical 'one') and NOS (No Signal: Input signal with insufficient bit rate or insufficient density of ones).

The single rail bit stream is then processed by the Receiver.

### Receiver

The following functions are performed:

- Synchronization of pulse frame
- Synchronization of CRC4 multi-frame
- Error Indication when pulse frame synchronization is lost. In this case, AIS is sent to the system side. If the receiver is in transparent mode, AIS is suppressed.
- Initiating and controlling of re-synchronization after loss of synchronization. This may be carried out automatically by the SA9101, or under user control via the microprocessor interface.
- Detection of Remote Alarm Indication from the incoming data stream.
- Separation of service bits and data link bits. This information is stored in special status registers.
- Generation of control signals to synchronize the CRC checker, the parity generator, and the Receive Speech Memory control unit.

If the multi-frame format is selected, CRC checking of the Incoming data stream is done by generating check bits for a CRC submultiframe according to the CRC 4 procedure (PCM30, refer to CCITT Rec. G704). These bits are compared with those check bits that are received during the next CRC sub-multiframe. If there is a mismatch, the CRC error counter will be incremented. This 8-bit counter (default) can be extended to 10-bit length, by writing to the control registers.



### Receive Speech Memory

The speech memory is organized as a two-frame elastic buffer with a size of 64 x 9 bit (8-bit channel data plus one parity bit).

The functions are:

- Compensation of Input wander and jitter. Maximum wander amplitude (peak-to-peak) = 190 UI (1UI = 488 nS)
- Frame alignment between system frame and receive route frame
- Reporting and controlling of slips

Controlled by special signals generated by the Receiver, the unipolar bit stream is converted into bit-parallel, channel-serial data which is circularly written to the speech memory. At the same time, a parity signal is generated over each channel and also stored in the speech memory.

Reading of stored data is controlled by the System Clock (SCLK) and the Synchronization Pulse (SYPQ) in conjunction with the programmed offset values for the Receive timeslot/ Clock slot Counters. After conversion into a serial data stream and parity checking (errors are reported via the status registers), the data is given out via port DRO. Channel parity information is output at port CHPAR with selectable parity type (odd or even). Two bit rates (2048/4096 kbps) are selectable via the microprocessor interface.

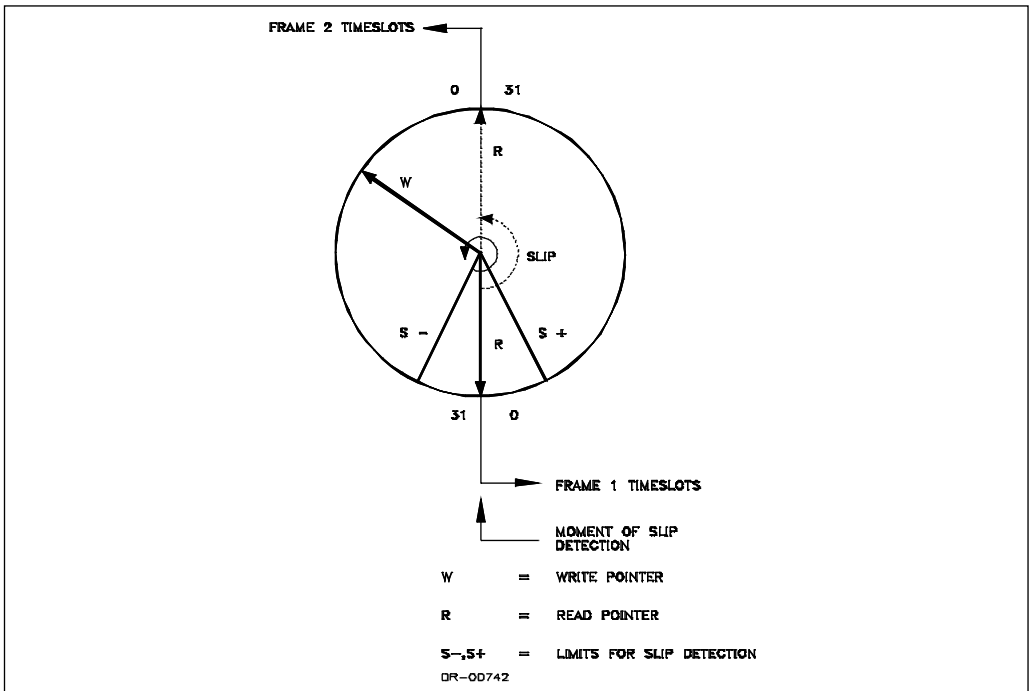

**Figure 1.0: The Receive Speech Memory as circularly organized memory**

Figure 1.0 illustrates the operation of the receive Speech Memory:

A slip condition is detected when the Write Pointer (W) and the Read pointer (R) of the memory are nearly coincident, i.e. the Write pointer is within the Slip Limits (S+, S-). If a slip condition is detected, a negative slip (the next received frame is skipped) or a positive slip (the previous received frame is read out twice) is performed at the System Interface, depending on the difference between RCLK and SCLK, i.e. on the position of pointer R and W within the memory.

To reduce delay, the Receive Speech Memory can be switched to one frame length. For correct operation, System Clock SCLK and Synchronization Pulse SYPQ have to be derived from the Receive Route Clock RCLK and the Receive Frame Synchronous Pulse RFSPQ (PLL application). In Single Frame Mode, however, it is not possible to perform a slip after the slip condition has been detected.

### Receive Transparent Mode

If enabled, the frame aligner does not try to synchronise on the received data if synchronisation is lost. The AIS to the System Interface is disabled. The data appears on the System Interface synchronised to the System Clock (SCLK) as received.

### Transmit path

The PCM data is received from the system internal highway at port DXI at 2048 kbps or 4096 kbps. The channel assignment is equivalent to the receive direction. Data in invalid timeslots will be ignored.

Latching of data is controlled by the System Clock (SCLK) and the Synchronization Pulse (SYPQ), in conjunction with the programmed offset values of the Transmit Timeslot/Clockslot Counters.

The Transmit Route Clock (XRCLK) is derived directly from the system clock by an internal clock divider. Consequently, the data received from the system interface is switched through without the need of intermediate storage.

The parity generation/checking mechanism is symmetrical to the receive path. The channel data is checked with the channel parity information generated internally or externally (input at port XCHPAR with selectable parity type). Errors are reported to the microprocessor interface. To avoid difficulties with external parity generation, the parity signal for non-speech data (TS0 and TS16) is ignored.

### Transmitter

The serial bit stream is then processed by the transmitter which has the following functions:

- Frame/multiframe synthesis of one of the selectable framing formats
- Insertion of service and data link information.
- Remote Alarm generation
- CRC generation and insertion of CRC bits



## **Transmit Link Interface**

Similar to the Receive Link Interface two different data types with selectable active polarity for the output are supported:

- Dual rail data (PCM[+], PCM[-]) at ports DXA, DXB with selectable duty cycle (50% or 100%) transmitted to a Line Interface Unit. Single rail data is converted into a dual rail bit stream. The HDB3 line code is employed.
- Unipolar data at port OPOUT with 100% duty cycle transmitted to a fibre optical interface.

Clocking of data is carried out on the positive transitions of the Transmit Route Clock: XRCLK (2048 kHz). XRCLK is generated by the SA9101.

Additionally, the dual rail outputs XTOP and XTOM are provided for test applications.

## **Additional functions**

### **Alarm Interrupt**

Normally, the control of data transmission via the PCM line is carried out by polling the internal status registers of the SA9101 at equal time intervals. However, for fast error handling the option exists to configure a specific output port as interrupt port (AINT). This signal may be connected to an interrupt input of the on-board processor. Triggering of the output may be caused by up to 10 maskable interrupt sources.

### **Single Channel Loop Back**

As one of the extended test options, the Single Channel Loop Back enables reflection of a selected channel back to the system interface at port DRO.

### **TS16 Extraction/Insertion**

TS16 data can be extracted/inserted via the  $\mu$ P or the DMA facility provided. For  $\mu$ P interface, RREQ/XREQ act as interrupts. When one of these interrupts is received two bytes must be read/written consecutively before next frame information is written into it. For DMA operation see detailed timing diagram, Fig 7.3. (See DIU Controller Pin description table, CR6B6 Register and SR5B5 Register descriptions.)

Data Extraction/Insertion is also possible through the serial ports DRO and DXI by using a multiplexer in conjunction with the control signals RCAS/TCAS generated by the SA9101.

### **Serial Data extraction on System Side**

Together with the Double Frame Marker generated by the SA9101, any position in the serial data can be pointed to, for extraction.

### **Idle Code Insertion**

In TX direction any channel can be selected for idle code insertion using the Idle Channel Register bank.

## Signal Processing

### General

PCM line bit rate	:	2048 kbps $\pm$ 50 ppm
Single frame length	:	256 bit, No. 1 ... 256
Framing frequency	:	8 kHz
Organization	:	32 timeslots, No. 0 ... 31 with 8 bits each, No. 1 ... 8

Timeslot 0 is reserved for frame alignment word and service Information. Switching between the two word framing formats (Doubleframe/CRC-Multiframe) is done via the Control Register.

### Line Interfacing

- Dual rail data with HDB3 coding in conjunction with double violation detection or extended code violation detection. Errors are counted by the Code Violation Counter. (Selectable between 8 and 10 bit counter.)
- Single rail unipolar data with no zero suppression algorithm.

### General alarms

- AIS : Detection and Transmission.
- NOS : No Signal Detection.
- RAI : Remote Alarm Indication and Transmission.

### Channel Assignment (including Timeslot 0)

The channel (timeslot) assignment from the PCM line to the system internal highway is performed without any changes of channel numbering (TS0,...,TS31). In the receive direction, the contents of timeslot 0 are switched through transparently. In the transmit direction, the contents of timeslot 0 of the outgoing PCM frame are normally generated by the SA9101. Additionally, one of three Transparent Modes can be selected to achieve transparency either for  $S_n$  bit information,  $S_n$  and  $S_i$  bit information or for all of the data in timeslot 0.

$S_n$  and  $S_i$  bits can be fed through from the system interface (DXI) by activating transparent mode CR5B4, known as Timeslot 0 Signalling Transparent mode. Only  $S_n$  bits can be fed through DXI when the Extended Signalling Transparent mode is activated.

Priority is in the following order:

- Highest - Timeslot 0 Transparent Mode (CR5B5)
- Medium - Timeslot 0 Extended Signalling Transparent Mode (CX1B6)
- Lowest - Timeslot 0 Signalling Transparent Mode (CR5B4)

Transparent Mode	Framing (incl. CRC)	A Bit	S <sub>n</sub> bits	S <sub>i</sub> bits	
				Double frame	CRC
Non-Transparent	Internally generated	CR4B5	CR4B0..4 <sup>1</sup>	CR4B7 & CR5B2	CR5B0 & CR5B1 <sup>2</sup>
CR5B5	via DXI	via DXI	via DXI	via DXI	via DXI
CR5B4	Internally generated	CR4B5	via DXI	via DXI	via DXI
CX1B6	Internally generated	CR4B5	via DXI	CR4B7 & CR5B2	CR5B0 & CR5B1 <sup>2</sup>

- Notes:** 1) The S<sub>n</sub> bit stack may be used optionally  
 2) Automatic transmission of submultiframe error indication is selectable

**General signalling**

- S<sub>n</sub> (Y) bits.
- S<sub>i</sub> bits.

**Signalling**

- CCS: For Common Channel Signalling the use of timeslot 16 is recommended. The use of CCS is allowed with both the doubleframe and the CRC-Multiframe format.
- CAS-CC: For Channel Associated Signalling the use of timeslot 16 is recommended. The autonomous CAS multiframe structure is not related to a doubleframe or a CRC-Multiframe structure (refer to CCITT G704 paragraph 3.3.3). Note: CAS multiframe synchronization and syntheses are not performed by the SA9101.

**Doubleframe format**

The framing structure is defined by the contents of timeslot 0 (refer to table 1).

Alternate Frames	Bit Number							
	1	2	3	4	5	6	7	8
Frame containing the frame alignment signal	S <sub>i</sub> Note 1	0	0	1	1	0	1	1
Frame not containing the frame alignment signal	S <sub>i</sub> Note 1	1 Note 2	A Note 3	S <sub>n0</sub>	S <sub>n1</sub>	S <sub>n2</sub>	S <sub>n3</sub>	S <sub>n4</sub> Note 4

**Table 1: Allocation of bits 1 to 8 of Timeslot 0**

1.  $S_i$  bits: reserved for international use. If not used, these bits should be fixed to '1'. Access to received information via bits SR4B7 and SR5B2. Transmission is enabled via bits CR4B7 and CR5B2.
2. Fixed to '1'. Used for synchronization.
3. Remote Alarm Indication: In normal operation '0'; in alarm condition '1'. Transmission is done through CR4B5 and reception is indicated by interrupt (maskable) and SR0B4.
4.  $S_n$  (Y) bits: Reserved for national use. If not used, they should be fixed at '1'. Access to received information via bits SR4B[4-0]. Transmission is enabled via bits CR4B[4-0]

### Synchronization procedure

Synchronization status is reported via  $\mu$ P-interface Status Register. Framing errors are counted by the Framing Error Counter. Loss of synchronization is reached after detecting 3 consecutive incorrect FAS words or 3 consecutive incorrect service words (bit 2  $\neq$  1 in timeslot 0 of every frame not containing the frame alignment word). When this occurs, counting of framing errors will be stopped and AIS will be sent to the system internal highway.

The re-synchronization procedure starts automatically after entering loss of synchronisation state. Additionally, it may be invoked under user control via the  $\mu$ P-interface.

Synchronized state is reached after detecting:

- a correct FAS word in frame n,
- the presence of the correct service word (bit 2 = 1) in frame n+1
- a correct FAS word in frame n+2

Normal Synchronized operation starts with the data in frame n+2.

### CRC-Multiframe

The multiframe structure shown in table 2 is enabled via  $\mu$ P-interface.

Multiframe	:	2 submultiframes = 2*8 frames
Multiframe alignment	:	bit 1 of frames 1,3,5,7,9,11 with the pattern '001011'
CRC bits	:	bit 1 of frames 0,2,4,6,8,10,12,14
CRC block size	:	2048 bit (length of a submultiframe)
CRC procedure	:	CRC4, according to CCITT Rec. G704

The CRC procedure is automatically invoked when the multiframe structure is enabled. CRC errors in the received data stream are counted by the CRC Error Counter (max. one error per sub-multiframe). This 8-bit counter is extendable to 10 bit length.

**Synchronization procedure**

Multiframe alignment is assumed to have been lost if double-frame alignment has been lost or 2 consecutive multiframe patterns are received with an error.

The multiframe re-synchronization procedure starts when doubleframe alignment has been regained. It may also be invoked by the user through the  $\mu$ P-interface. The CRC checking mechanism will be enabled after the second correct multiframe pattern has been found. However, CRC errors will not be counted in unsynchronized state.

The (multiframe) synchronized state is reached after detecting two correct multiframe alignment patterns in multiframe n and multiframe n+1. The CRC4 flag SR0B1 will be reset. Resynchronization starts whenever two consecutive multiframe are received with incorrect multiframe alignment pattern.

	Sub-Multiframe	Frame No.	Bits 1 to 8 of the frame							
			1	2	3	4	5	6	7	8
Multiframe	I	0	C <sub>1</sub>	0	0	1	1	0	1	1
		1	0	1	A	S <sub>n0</sub>	S <sub>n1</sub>	S <sub>n2</sub>	S <sub>n3</sub>	S <sub>n4</sub>
		2	C <sub>2</sub>	0	0	1	1	0	1	1
		3	0	1	A	S <sub>n0</sub>	S <sub>n1</sub>	S <sub>n2</sub>	S <sub>n3</sub>	S <sub>n4</sub>
		4	C <sub>3</sub>	0	0	1	1	0	1	1
		5	1	1	A	S <sub>n0</sub>	S <sub>n1</sub>	S <sub>n2</sub>	S <sub>n3</sub>	S <sub>n4</sub>
		6	C <sub>4</sub>	0	0	1	1	0	1	1
	7	0	1	A	S <sub>n0</sub>	S <sub>n1</sub>	S <sub>n2</sub>	S <sub>n3</sub>	S <sub>n4</sub>	
	II	8	C <sub>1</sub>	0	0	1	1	0	1	1
		9	1	1	A	S <sub>n0</sub>	S <sub>n1</sub>	S <sub>n2</sub>	S <sub>n3</sub>	S <sub>n4</sub>
		10	C <sub>2</sub>	0	0	1	1	0	1	1
		11	1	1	A	S <sub>n0</sub>	S <sub>n1</sub>	S <sub>n2</sub>	S <sub>n3</sub>	S <sub>n4</sub>
		12	C <sub>3</sub>	0	0	1	1	0	1	1
		13	S <sub>i</sub> *	1	A	S <sub>n0</sub>	S <sub>n1</sub>	S <sub>n2</sub>	S <sub>n3</sub>	S <sub>n4</sub>
		14	C <sub>4</sub>	0	0	1	1	0	1	1
15		S <sub>i</sub> *	1	A	S <sub>n0</sub>	S <sub>n1</sub>	S <sub>n2</sub>	S <sub>n3</sub>	S <sub>n4</sub>	

S<sub>i</sub>\*: Spare bits for international use. Access to received information via  $\mu$ P-interface. (For transmission, automatic transmission of sub-multiframe error or insertion through  $\mu$ P-interface is selectable).

S<sub>n</sub>: Spare bits for national use. Additionally, the 5-byte stacks for receive and transmit are provided.

C1..C4: Cyclic Redundancy Check bits.

A: Remote Alarm Indication.

**Table 2: CRC-Multiframe Structure**

### $S_n$ -bit access

Due to new signalling procedures using the five  $S_n$  bits ( $S_{n0} \dots S_{n4}$ ) of every other frame of the CRC Multiframe structure, two possibilities of access via the microprocessor are supported:

- The standard procedure allows reading/writing the  $S_n$ -bit registers without further support. The  $S_n$ -bit information will be updated every other frame.
- The advanced procedure, allows reading/writing two  $S_n$ -bit stacks each with a size of 5 bytes. Two status bits (SR5B6 and SR5B7) provide an indication for updating the stack information by reading/writing five bytes per multiframe from/to the assigned stack address. To avoid loss of information, the status bits should be monitored at time intervals less than 2ms (1,5ms recommended). With the first access to a stack, the associated status bit will be reset.

A Transmit or Receive Multiframe Begin interrupt is supported when Alarm Interrupt mode is enabled (CR5B6 and CR5B7).

If one makes use of the  $S_n$  bit stack in the Double frame format it is necessary that this be done in conjunction with an externally enforced Multi-frame structure to ensure the proper recovery of data on the far side. This is only possible in the Non-Transparent Mode for Timelot 0.

#### Organization of the stacks:

The sequentially received  $S_n$  bits ( $S_{n0}$  up to  $S_{n4}$ ) of odd numbered frames of the multiframe structure are re-organized to bytes containing the  $S_n$ -information of the same level ( $S_{n0}$  byte up to  $S_{n4}$  byte). The  $S_{n4}$  byte is the first byte to be read or written via the microprocessor interface (refer to table 3).

Alternatively,  $S_n$  bits may be processed via the system interface, if one of the transparent modes are enabled.

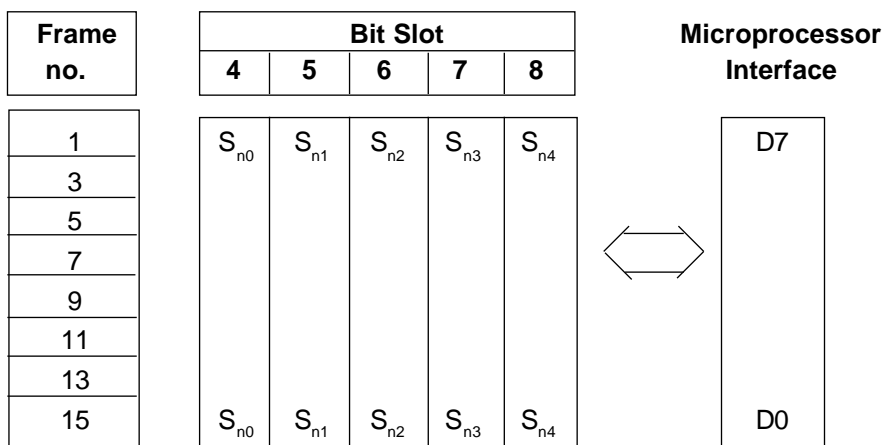

Table 3: Organisation of the  $S_n$ -Bit Stacks



**S<sub>i</sub>-bit access**

In accordance with CCITT signalling requirements, the S<sub>i</sub> bits of frame 13 and frame 15 of the CRC Multi-frame can be used to indicate received error submultiframes:

Submultiframe I status	:	S <sub>i13</sub>
Submultiframe II status	:	S <sub>i15</sub>
no CRC error	:	S <sub>i</sub> = 1
CRC error	:	S <sub>i</sub> = 0

S<sub>i</sub>-bits insertion can be done through the μP-interface (in non-Transparent and Extended Timeslot 0 Signalling Transparent modes) or, if enabled, automatically by the SA9101 without any intervention of the microprocessor. In this case, the status information of received sub-multiframe, is inserted in S<sub>i</sub>-bit position of the outgoing CRC-Multiframe. A third option is via the system interface should the Timeslot 0 Transparent or Timeslot 0 Signalling Transparent modes be selected.

**Differences to Siemens ACFA (PEB2035 V4.1)**

1. Automatic Force Resynchronisation feature for CRC mode, CR1B6 (Mode Register, bit AFR), is not used because this feature is implemented in hardware to be carried out automatically.
2. S<sub>n</sub> bit stack  
CR1B5 (Mode Register, bit ENSN) enables the S<sub>n</sub> bit stack for both CRC Multiframe and Double frame formats.
3. CRC Multiframe enable  
CR1B3 (Mode Register, bit CRC) switches only between CRC Multiframe and DoubleFrame formats. No need for CX1B7 (EMOD DFSN) to enable S<sub>n</sub> bit stack in Double Frame format due to point 2 above.
4. Service Word Condition Disable  
CR9B7 (RC1.SWD) is not used. Always functions in Standard Operation mode, i.e. 3 consecutive incorrect service words will cause loss of synchronisation.
5. Select loss of Sync Condition  
CR9B6 (RC1.ASY4) is not used. Always functions in Standard Operation Mode (according to CCITT Rec.), i.e. 3 consecutive incorrect service words will cause loss of synchronisation.
6. Extended DMA Mode  
CX1B1 (EMOD EDMA) is not used. The DMA facility must always read/write two consecutive bytes. This is the only mode of operation therefore no selection is required.
7. Disable AIS to System Interface  
CX1B0 (EMOD DAIS) is redefined. Siemens allowed for AIS selection for receive transparent mode. However, in Receive transparent mode synchronisation may be lost and therefore AIS is always disabled in the SA9101. This bit is redefined to provide a double frame marker to provide synchronisation to the Double Frame format.
8. Unique feature in Timeslot 0 Signalling Transparent Mode  
The SA9101 is capable of recognising the frame alignment pattern and therefore will not overwrite the S<sub>n</sub> and S<sub>i</sub> information inserted externally (via DXI) in the desired bit locations of the alternating timeslot 0 words.



## SA9101 REGISTER DESCRIPTION

## Control Register

## Default setting

After RESET, the SA9101 is initialized for PCM30 doubleframe format with register values listed in Table 4.

Register Name	Register ADR	Reset Value	Meaning
CR0B[7..0]	0	00H	Alarm Interrupt mode disabled/Double Violation Detection, no influence on error counting, channel parity alarms, data transmission via port DRO, or synchronization. No Alarm simulation. Status register read enabled.
CR1B[7..0]	1	C0H	PCM30-doubleframe format with dual rail (RZ) line interface ports/4 Mbps system interface mode/no AIS transmission to remote end/ $S_n$ -bit stacks are disabled.
CR2B[7..0]	2	00H	Channel Parity Check is active for channel 0.
CR3B[7..0]	3	00H	Channel Loop Back and Single Frame mode are disabled.
CR4B[7..0]	4	40H	All bits of the transmitted service word are cleared (bit 2 excl.).
CR5B[7..0]	5	00H	Spare bit values and additional interrupts are cleared.
CR6B[7..0]	6	00H	Outputs for transmit dual rail line data and assigned test data are active low, internal signalling stacks and external transmit channel parity are disabled. The Transmit Clock slot Offset is cleared.
CR7B[7..0]	7	40H	4096 kHz system clock frequency. The Transmit Timeslot Offset is cleared.
CR8B[7..0]	8	30H	Even Receive Channel Parity, Receive dual rail line data inputs are active low. The Receive Clock slot Offset is cleared. CRC Error Counter Extension is disabled.
CR9B[7..0]	9	C0H	The Receive Timeslot Offset is cleared.
CRAB[7..0]	A	FFH	The Transmit Signalling stack is cleared. Its values are not readable until the signalling stack mode is enabled.
CRBB[7..0]	B	Undefined	$S_n$ bit stack contents unknown.
CRCB[7..0]	C	00H	No interrupt source is enabled.
CRDB[7..0]	D	54H	Idle Channel Code is set to '54' hex.
CX1B[7..0]	1	00H	Half-bauded mode
CX6B[7..0]	6	00H	Normal operation
CX7B[7..0]	7	00H	Normal operation
CX8B[7..0]	8	00H	Normal operation
CX9B[7..0]	9	00H	Normal operation

Table 4: Initial Values after reset



## Detailed Description

## ADR 0 ALARM Control

Register Name	Bit	Description
CR0B0	0	Alarm simulation A "1" initiates error simulation of alarm indication signal (AIS), slip, parity, CRC, no signal, loss of frame alignment, remote alarm, code violations and framing errors. Error counters for frame errors, code violations and CRC errors will be incremented.
CR0B1	1	Force re-synchronisation Setting of this bit initializes resynchronization to establish normal frame alignment and, if enabled, CRC4 frame re-synchronization. Resetting is not necessary.
CR0B2	2	Clear CHNL Parity Alarm Latch Setting of this bit forces reset of CHNL Parity error alarms. Status-registers ADR 0, bit 2 and ADR 5, bit 3, 4 will be reset to "0".
CR0B3	3	Send AIS towards System interface (DRO), i.e. switching network (SN). Device sends AIS (continuously one's) to the SN. Tests of the speech memory in loopback mode are not effected.
CR0B4	4	Disable Error Counters This bit can be set 1 $\mu$ s before the contents of the error counters are read to get stable values. The error counters will be reset after this bit is reset to zero. No errors are counted while this bit is active. This procedure has been implemented to maintain compatibility with the previous frame aligners. If an error counter is read without setting this bit previously, only the addressed error - counter will be reset after read -access has been completed.
CR0B5	5	Enable Control Registers Read If this bit is set to one, the control registers (ADR0-ADR5) are selected instead of the status registers during read operation.
CR0B6	6	Enable Full HDB3-Error Detection This bit enables HDB3 check for groups of more than 3 spaces (zeros)
CR0B7	7	Enable Alarm Interrupt Mode Output DFPY changes its function to AINT while this bit is at "1".

**Note:** All "Not used" bits must be set to zero in all control registers



**ADR 1 SA9101 Configuration**

<b>Register Name</b>	<b>Bit</b>	<b>Description</b>
CR1B0	0	Send AIS Towards Remote End Setting of this bit causes transmitting AIS towards the remote end. The test data-outputs are not affected.
CR1B1	1	Select Interface Mode Switches operation mode on DRO and DXI. 1 = 2 Mbits/s 0 = 4 Mbits/s
CR1B2	2	Enable optical Interface If set to one, OPIN is enabled instead of dual rail ports.
CR1B3	3	Activate CRC4 A "1" activates CRC4-operation
CR1B4	4	Select counter mode Only two channels per frame are counted if set to "1".
CR1B5	5	Enable Sn-bit Stack In CRC-mode, the transmit and receive Sn bit stacks can be used instead of the registers for transmit and receive service word. Transmitting from Sn-Bit stack is disabled if one of the timeslot 0 transparent modes is enabled.
CR1B6	6	Not used (fixed 1)
CR1B7	7	For Re-synchronisation of CRC4 Multiframe

**ADR 2 Channel Parity Check**

<b>Register Name</b>	<b>Bit</b>	<b>Description</b>
CR2B[0-4]	0-4	Selects channel
CR2B5	5	A "1" disables parity-check of selected channel
CR2B6	6	Not used
CR2B7	7	Extended Mode Register access enabled Allows access to the Extended Control Registers CX1 to CX9

**ADR 3 Channel Loop Back**

Register Name	Bit	Description
CR3B[0-4]	0-4	The addressed timeslot (1..31) is looped back to the system interface. Idle channel code content of control register D for this channel is sent to remote end. Code "00000" deactivates loop-back.
CR3B5	5	A "1" disables loop back of selected channel
CR3B6	6	Select single frame delay mode Signal delay set to max. one frame length., if this bit is at "1".
CR3B7	7	Alarm Interrupt Acknowledge A "1" clears AINT. Resetting is not necessary.

**ADR 4 Service Word**

Register Name	Bit	Description
CR4B[0-4]	0-4	Y (Sn) bits for national use These bits are inserted in the service word, if $S_n$ -bit stack mode is disabled and no TS0 transparent mode is enabled.
CR4B5	5	Send Remote Alarm to Remote End A "1" causes bit 3 of service word to be set to "1". It is ignored if TS0 transparent mode is enabled.
CR4B6	6	Synchronization bit, internally set to "1". It cannot be overwritten.
CR4B7	7	First bit of service word if double-frame format enabled, and Non-transparent or Extended TS0 Signalling Transparent modes enabled.



## ADR 5 Data link bits for internal use

Register Name	Bit	Description	
CR5B0	0	$S_i$ (X)-bit in frame 15	Only if CRC4 processing activated and Non-transparent or Extended TS0 Signalling Transparent mode enabled.
CR5B1	1	$S_i$ (X)-bit in frame 13	
CR5B2	2	$S_i$ (X)-bit of frame alignment signal for international use, if double frame format enabled and Non-transparent or Extended TS0 Signalling Transparent mode enabled.	
CR5B3 CRC4	3	Automatic Transmission of Submultiframe Status (only in mode, and Non-transparent or Extended TS0 signalling transparent mode). Instead of transmitting $S_i$ bits (CR5 bit 0 and 1), the sub-multiframe status is inserted (SR 8, bit 1 -> X-bit(13), SR8 bit 0 -> X-bit(15).	
CR5B4	4	Timeslot 0 Signalling Transparent mode. In Double frame and CRC Multiframe modes $S_n$ and $S_i$ bits of Timeslot 0 are transmitted as applied on DXI.	
CR5B5	5	Timeslot 0 Full Transparent mode All information is transmitted as applied on DXI.	
CR5B6	6	Interrupt Mask "Begin Receive Multiframe"	A "1" enables interrupt source only if alarm interrupt mode enabled
CR5B7	7	Interrupt Mask "Begin Transmit Multiframe"	

**ADR 6 Transmit control 0**

Register Name	Bit	Description
CR6B[0-2]	0-2	Set value for transmit bit counter (bit 0-2) which is loaded in the transmit counter when the synchronization pulse is active.
CR6B3	3	Transmit Test data Polarity Outputs are active low if bit is at "0"
CR6B4	4	External Transmit Channel Parity Type 0 : Even 1 : Odd
CR6B5	5	Enable External Transmit Channel Parity Input. The internally generated channel parity signal is compared with the signal at the channel parity input if this register bit is set to "1". For signalling, the parity-value on the parity input is ignored, because it is generated internally.
CR6B6	6	Enable Internal Signalling Stack. If set to "1" the two-byte stacks for receive and transmit signaling data (timeslot 16) are enabled. Access to the TS16 Signalling Stack is possible via $\mu$ P interface or by means of DMA. The RREQ and XREQ signals can be used either as interrupts or as DMA request signals. For DMA transfer the ACKNLQ pin should be used for direct access to the stacks.
CR6B7	7	Transmit Data Output Polarity Bit at "1" : Dual rail outputs are active high, optical output is active low Bit at "0" : Dual rail outputs are active low, optical output is active high

**ADR 7 Transmit Control 1**

Register Name	Bit	Description
CR7B[0-5]	0-5	Set value for timeslot which is loaded into the transmit counter when the synchronization pulse is active
CR7B6	6	Mark CRC Alarm (Bit at "1" - Enable Alarm Source)
CR7B7	7	Select System Clock 0 : SCLK = 4.096MHz 1 : SCLK = 8.192MHz

**ADR 8 Receive Control 0**

Register Name	Bit	Description
CR8B[0-2]	0-2	Set value which is loaded into the receive bit counter when the synchronization pulse is active
CR8B3	3	Receive Data Input Sense Bit at "0" : Dual rail inputs are active low; optical input is active high Bit at "1" : Dual rail inputs are active high; optical output is active low
CR8B4	4	Not used
CR8B5	5	Not used
CR8B6	6	Receive Parity Type 0 : Even 1 : Odd
CR8B7	7	Enable CRC Error Counter Extension Bit at "0" : 8 bit counter Bit at "1" : 10 bit counter

**Note:** Receive Data Input Sense is only required for SR6B6 function. HDB3 is insensitive to polarity.

**ADR 9 Receive Control 1**

Register Name	Bit	Description
CR9B[0-5]	0-5	Set value for timeslot which is loaded into the receive counter when the synchronization pulse is active
CR9B[6-7]	6-7	Not used (fixed to "1")

**ADR A Transmit Signalling Stack (2 byte FIFO)**

Register Name	Bit	Description
CRAB[0-7]	0-7	Data for timeslot 16 Previous byte will be repeated, if not updated after request.

**ADR B Transmit  $S_n$ -bit stack**

Register Name	Bit	Description
CRBB[0-7]	0-7	5-byte $S_n$ -bit stack, which data will be inserted if CRC and stack mode enabled and no timeslot 0 transparent mode is enabled. The $S_n$ -bit information can be written into the transmit $S_n$ -bit stack when Transmit $S_n$ -bit flag is set (SR5B7).

**ADR C Alarm Interrupt Mask Register**

Register Name	Bit	Description
CRCB0	0	Code violation counter saturation
CRCB1	1	Frame error counter saturation
CRCB2	2	CRC error counter saturation
CRCB3	3	Receive slip indication
CRCB4	4	Receive remote alarm
CRCB5	5	No signal
CRCB6	6	Alarm Indication Signal
CRCB7	7	Loss of synchronisation

**Note:** The alarm source is enabled by setting the corresponding bit to "1".

**ADR D IDLE Channel code**

Register Name	Bit	Description
CRDB[0-7]	0-7	Idle Channel code During Loop-back, this code is sent to the remote end for the assigned channel. The specified pattern is also written into all channels selected via the Idle channel Register Bank, overwriting whatever information was in those timeslots.

**ADR E - F** Not used.

### ADR 1 Extended Mode Register 1

Register Name	Bit	Description
CX1B0	0	Enable Double Frame marker 0: Normal 1: Marker enabled and provided at CHPAR pin.
CX1B1	1	Not used
CX1B2	2	Fully Bauded data format 0: Half bauded 1: Fully bauded
CX1B3	3	Extended Code Violation Counter mode
CX1B4	4	S <sub>i</sub> -bit zero counter enable
CX1B5	5	Receive Transparent Mode
CX1B6	6	Time slot 0 Extended Signalling Transparent Mode. If set, in Double frame and CRC Multiframe formats only the S <sub>n</sub> bits are transmitted as applied at DXI
CX1B7	7	Not used

### ADR 6 - 9 Idle Channel Register Bank

CX6	IC0	IC1	IC2	IC3	IC4	IC5	IC6	IC7
CX7	IC8							IC15
CX8	IC16							IC23
CX9	IC24							IC31

0: Normal operation, 1: Idle Channel mode

**Note:** Timeslot 0 information is overwritten by idle channel code according to the transparency mode selected.

If Timeslot 16 Signalling stack is enabled and Timeslot 16 is selected for Idle Channel Code, the idle channel selection will be ignored. The stack has higher priority.



## Status Register

## ADR 0 PCM/SA9101 Alarm status

Register Name	Bit	Description
SR0B0	0	Slip Direction Indication 0 = negative slip, receive route clock frequency higher than internal system clock. 1 = positive slip, receive route clock frequency below system clock.
SR0B1	1	CRC4 Multiframe alarm Set after reset, multiframe synchronization lost or via uP-Interface with command "Force Re-synchronisation". Will be reset after receiving 2 multi-frames without errors.
SR0B2	2	Receive Channel Parity Error Set after device detects a channel parity error. Cleared by setting control register ADR 0, bit 2 (Clear Channel Parity Alarm Latch).
SR0B3	3	Receive Slip Indication This bit changes state when a frame is dropped ( $RCLK > SCLK$ ) or repeated ( $SCLK > RCLK$ ). A successful alarm-simulation causes one change.
SR0B4	4	Receive Remote Alarm Bit 3 of received service word.
SR0B5	5	Loss Of Synchronisation Will be set if incorrect frame alignment signal or service word was detected 3 times in sequence. Is automatically reset after sequence FAS-SW-FAS is received. Loss of synchronisation is also indicated if "No Signal" occurs because of no Route Clock.
SR0B6		Alarm Indication Signal (AIS) If less than two "0's" are detected in an incoming bitstream of 512 bits, this bit is set to "1".
SR0B7	7	No Signal If less than four "1's" are in a stream of 512 bits or no complete receive clock pulse occurs within 4 periods of the system clock, this bit is set to "1".

**ADR 1 Frame Error Counter**

Register Name	Bit	Description
SR1B[0-7]	0-7	8 bit counter will be incremented when an incorrect frame alignment word is detected in the synchronized state. An overflow is inhibited. During alarm simulation, the counter should increment every 250µs.

**ADR 2 Code Violation Counter**

Register Name	Bit	Description
SR2B[0-7]	0-7	8 bit counter which counts HDB3 code violations if no optical interface mode has been enabled. An overflow is inhibited. During alarm simulation, the counter should increment once for every four bits received. Counter can be extended to 10 bits by bit 3 of Extended Mode Register ADR1 (CX1B3).

**ADR 3 CRC4 Error counter**

Register Name	Bit	Description
SR3B[0-7]	0-7	8 bit counter which counts submultiframe CRC4 errors. An overflow is inhibited. During alarm simulation, the counter should increment once per submultiframe. The counter can be extended to a 10 bit counter by setting bit 7 of Receive Control Register ADR8 (CR8B7).

**ADR 4 Received Service Word**

Register Name	Bit	Description
SR4B[0-4]	0-4	Y-bits (Sn-bits) for national use
SR4B5	5	Bit 3 of service word (Receive Remote Alarm)
SR4B6	6	Fixed to "1".
SR4B7	7	First bit in received service word. It is fixed to "1" if the device is in CRC4-mode. Only used in Double Frame format.

## ADR 5 Data Link Bit for Internal Use

Register Name	Bit	Description
SR5B0	0	First bit of service word of frame 15.
SR5B1	1	First bit of service word of frame 13. These bits (0 and 1) are updated at the beginning of every received multiframe. If CRC4-mode is not enabled, these are set to "0".
SR5B2	2	First bit in FAS-word, used only in double Frame format (otherwise fixed at "1").
SR5B3	3	Transmit Parity Error If channel parity check is enabled, this bit is set after a channel parity error occurs. It is also set during alarm simulation.
SR5B4	4	Global Parity Error Set by a parity error in any transmitted or received channel. Also set during alarm simulation.
SR5B5	5	DMA Request Slip If the use of the TS16 signalling stacks is enabled, this bit is set if required access is not completed before the signalling stack gets updated.
SR5B6	6	Receive S <sub>n</sub> -bit Stack Flag Will be set at the beginning of every received CRC4 multiframe. It will be reset after a read access to the Receive S <sub>n</sub> -bit stack occurs or at the beginning of frame 15 in the multiframe. A read access should occur only if this flag is set to "1". Should be monitored at time intervals of less than 2ms.
SR5B7	7	Transmit S <sub>n</sub> -bit Stack Flag Will be set at the beginning of every transmitted CRC4 multiframe. It will be reset after a write access to the Transmit S <sub>n</sub> -bit stack or at the beginning of frame 15 in the multiframe. A write access should occur to the stack only if this flag is set. Should be monitored at time intervals of less than 2ms.

**ADR 6 Additional Receive Status**

Register Name	Bit	Description
SR6B6	6	Error On Primary Rate Line Receiver This bit is set while both dual rail inputs are active.
SR6B[0-5,7]	0-5,7	Not used, set to "1".

**ADR 7 Timeslot 16 Rx Stack**

Register Name	Bit	Description
SR7B[0-7]	0-7	Receive Signalling Data This stack contains two bytes of sequentially received signalling data (timeslot 16).

**ADR 8 S<sub>i</sub>-bits**

Register Name	Bit	Description	
SR8B0	0	Si(II) Bit will be set to "0" if a CRC check gives an error or synchronisation is lost. It will be set to "1", if no error is detected in sub-multiframe part II.	These bits are updated at the beginning of every received CRC multiframe. If the device is in double-frame format, these bits are fixed to "1".
SR8B1	1	Si(I) Bit will be set to "0", if a CRC check gives an error or synchronisation is lost. It will be set to "1", if no error is detected in sub-multiframe part I.	
SR8B[2-7]	2-7	Not used	

**ADR 9 CRC Error Counter Extension**

Register Name	Bit	Description
SR9B[0-1]	0-1	Bit 8 and 9 of CRC error counter, if in extended mode
SR9B[2-3]	2-3	Not used. (Fixed to "1")
SR9B[4-5]	4-5	Code Violation counter extension.
SR9B[6-7]	6-7	Not used. (Fixed to "1")

**ADR B Receive S<sub>n</sub>-bit stack**

Register Name	Bit	Description
SRBB[0-7]	0-7	This stack contains 5 bytes of S <sub>n</sub> -bit information. Bit 0..7 contains S <sub>n</sub> -bits of frame 15..1.

**ADR C-F** Not used

## TIMING

### μP Interface timing

#### Read cycle

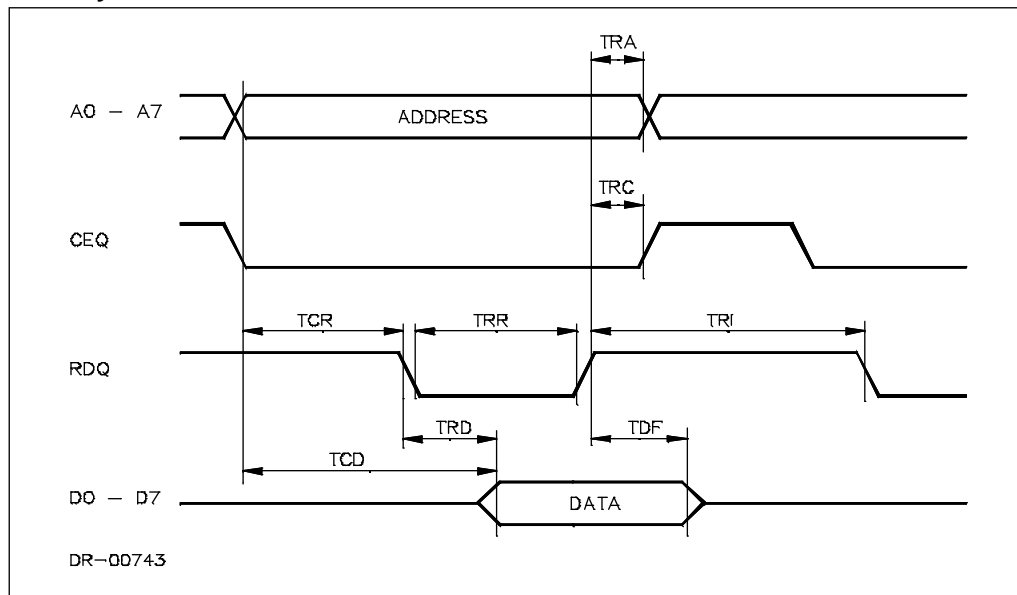

Figure 2: μP Read Timing

Symbol	Parameter	Limit Values		Unit
		Min.	Max.	
TCD	CEQ and ADDRESS valid to DATA valid		110	ns
TCR	CEQ and ADDRESS stable before RDQ	0		
TRD	RDQ to DATA valid		90	
TRR	RDQ pulse width	100		
TDF	DATA float after RDQ	10	30	
TRC	CEQ hold after RDQ	0		
TRA	ADDRESS hold after RDQ	0		
TRI	RDQ control interval	70		

Table 5: μP Read Timing

Write cycle

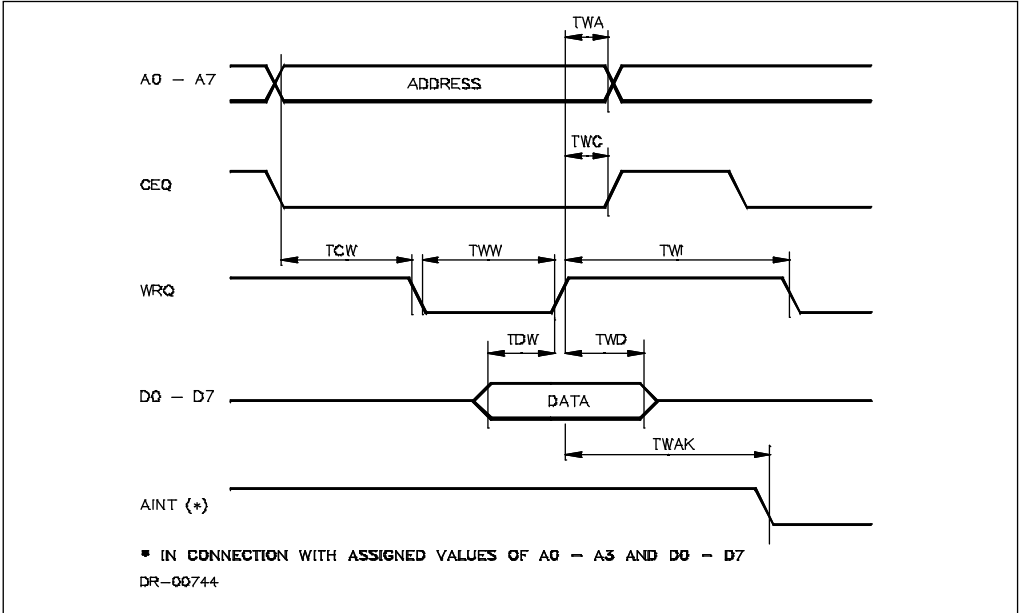

Figure 3:  $\mu$ P Write Timing

Symbol	Parameter	Limit Values		Unit
		Min.	Max.	
TCW	CEQ and ADDRESS valid to WRQ valid	30		ns
TDW	DATA setup before end of write	35		
TWD	DATA hold after WRQ	10		
TWW	WRQ pulse width	80		
TWC	CEQ hold after WRQ	10		
TWA	ADDRESS hold after WRQ	10		
TWI	WRQ control interval	70		
TWAK	Interrupt acknowledge delay		2*TCP4 + 60 4*TCP8 + 80	

Table 6:  $\mu$ P Write Timing

## DMA cycle

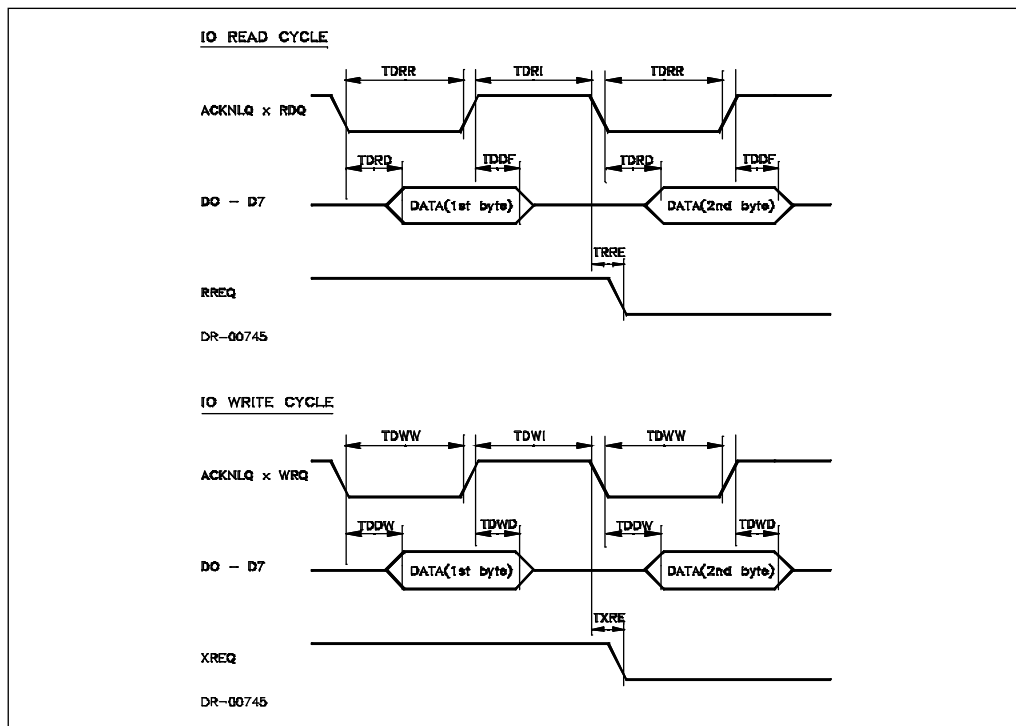

Figure 4: DMA Timing

Symbol	Parameter	Limit Values		Unit
		Min.	Max.	
TDRD	RDQ to DATA valid		90	ns
TDDF	DATA float after RDQ	10	30	
TDRR	RDQ pulse width	100		
TDRI	RDQ control interval	70		
TRRE	RREQ reset after RDQ		100	
TDDW	DATA setup before end of write	35		
TDWD	DATA hold after WRQ	10		
TDWW	WRQ pulse width	80		
TDWI	WRQ control interval	70		
TXRE	XREQ reset after WRQ		100	

Table 7: DMA Timing



Serial Interface Timing

System Interface timing

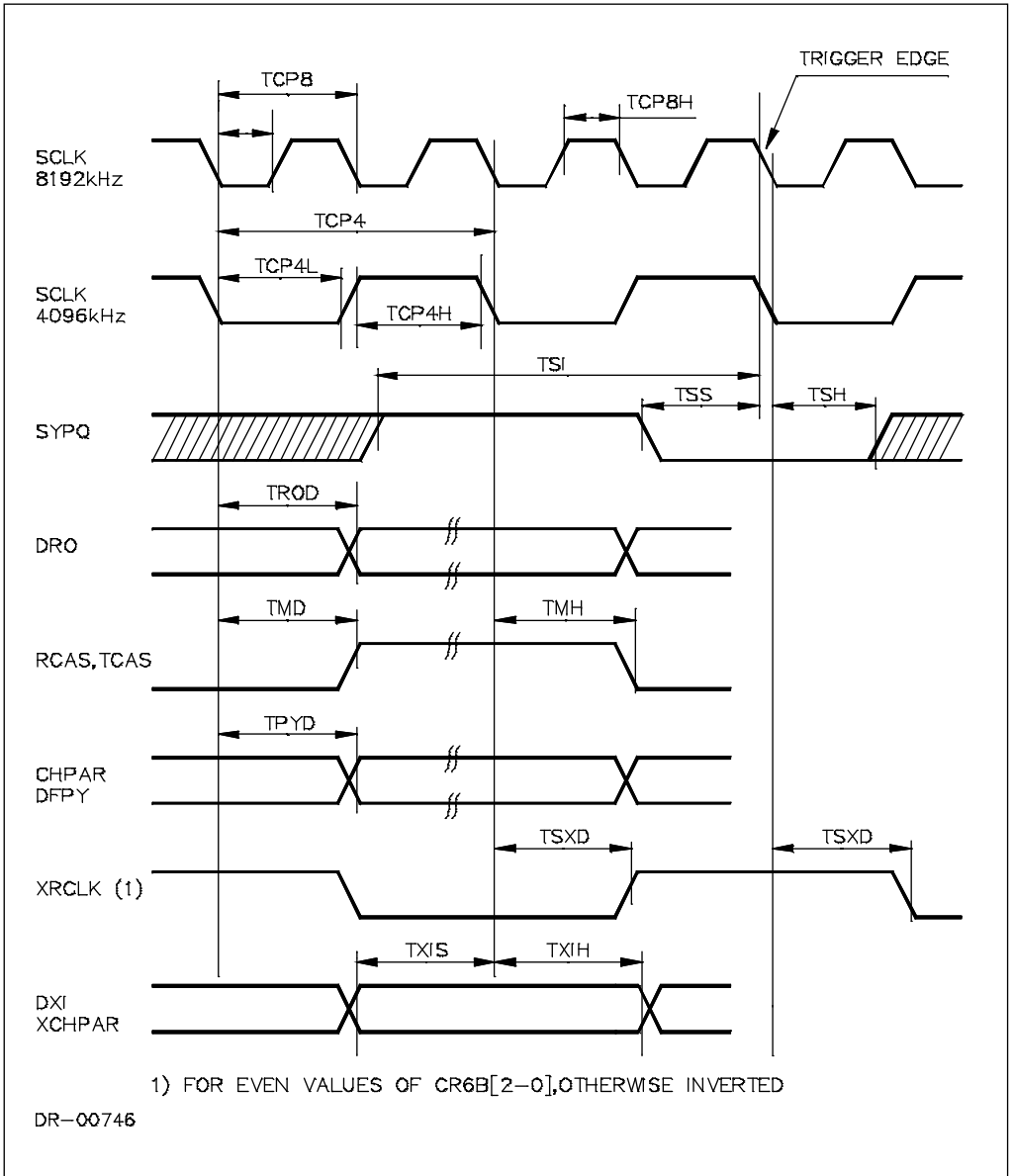

FIGURE 5: SYSTEM INTERFACE TIMING

Symbol	Parameter	Limit Values				Unit
		4096kHz SCLK		819kHz SCLK		
		Min.	Max.	Min.	Max.	
TCP8	SCLK period 8MHz			typ. 122		ns
TCP8L	SCLK period 8MHz low			40		
TCP8H	SCLK period 8MHz high			40		
TCP4	SCLK period 4MHz	typ. 244				
TCP4L	SCLK period 4MHz low	50				
TCP4H	SCLK period 4MHz high	50				
TSS	SYPQ setup time	40	TCP4-30	TCP8-40	TCP8-40	
TSH	SYPQ hold time	40		40		
TSI	SYPQ inactive setup	TCP4+30		2*TCP8 +30		
TROD	RDQ propagation delay		90		110	
TMD	Marker propagation delay		100		120	
TMH	Marker hold		100		120	
TPYD	Parity propagation delay		100		120	
TSXD	XRCLK to SCLK delay		100		120	
TXIS	Transmit data setup	30		30		
TXIH	Transmit data hold	30		30		

Table 8: System Interface Timing

Line Interface Timing

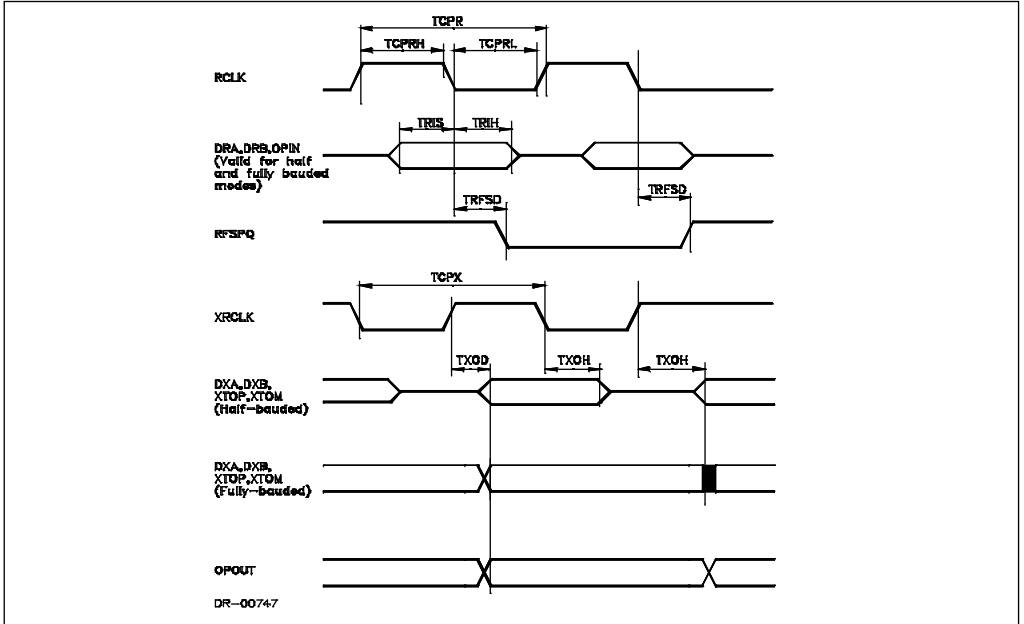
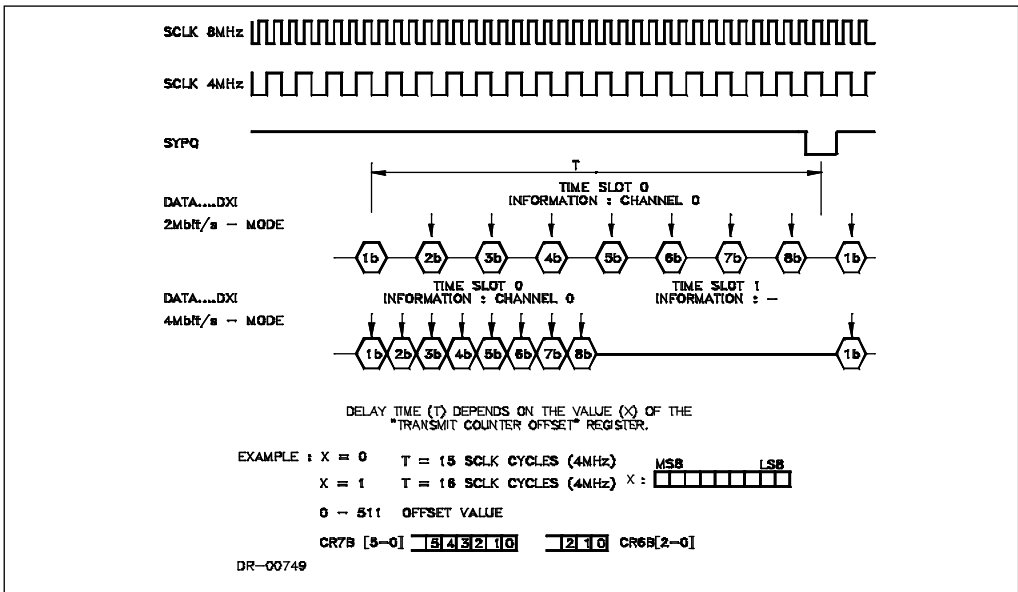
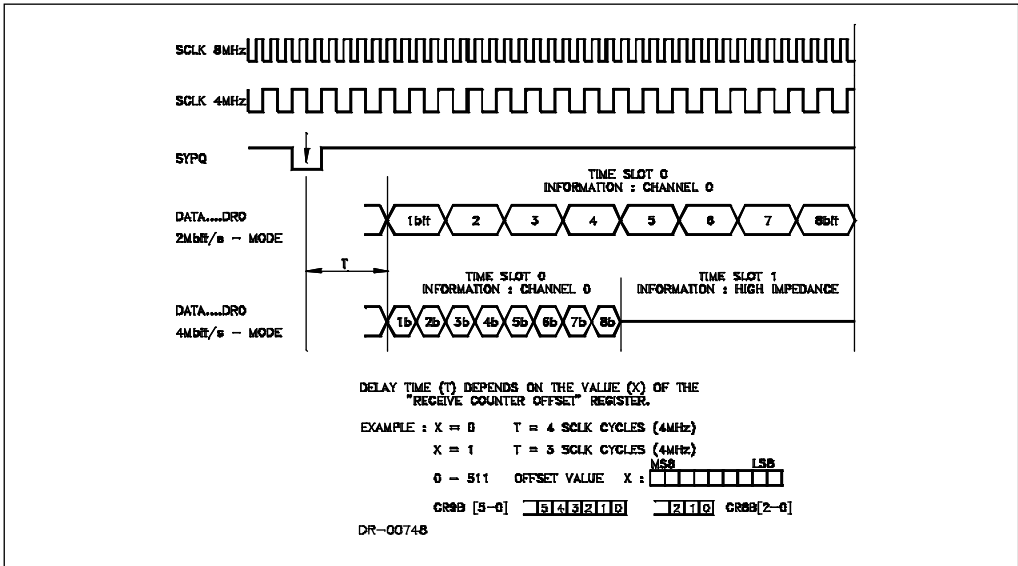

Figure 6: Line Interface Timing

Symbol	Parameter	Limit Values		Unit
		Min.	Max.	
TCPR	RCLK clock period	typ. 488		ns
TCPRL	RCLK clock period low	100		
TCPRH	RCLK clock period high	100		
TRIS	Receive data setup	30		
TRIH	Receive data hold	30		
TRFSD	RFSPQ propagation delay		120	
TCPX	XRCLK clock period	2*TCP4 4*TCP8		
TXOD	Transmit data output delay		50	
TXOH	Transmit data output hold	0*	50	

Table 9: Line Interface Timing



**Disclaimer:** The information contained in this document is confidential and proprietary to South African Micro-Electronic Systems (Pty) Ltd ("SAMES) and may not be copied or disclosed to a third party, in whole or in part, without the express written consent of SAMES. The information contained herein is current as of the date of publication; however, delivery of this document shall not under any circumstances create any implication that the information contained herein is correct as of any time subsequent to such date. SAMES does not undertake to inform any recipient of this document of any changes in the information contained herein, and SAMES expressly reserves the right to make changes in such information, without notification, even if such changes would render information contained herein inaccurate or incomplete. SAMES makes no representation or warranty that any circuit designed by reference to the information contained herein, will function without errors and as intended by the designer.

**South African Micro-Electronic Systems (Pty) Ltd**

P O Box 15888,  
Lynn East,  
0039  
Republic of South Africa,

21 Eland Street,  
Koedoespoort Industrial Area,  
Pretoria,  
Republic of South Africa

Tel: 012 333-6021  
Fax: 012 333-8071

Tel: Int +27 12 333-6021  
Fax: Int +27 12 333-8071