

THREE PHASE POWER/ENERGY METERING IC WITH INSTANTANEOUS PULSE OUTPUT

FEATURES

- Functionally similar to the SA9105E and SA9105F, with reduced number of external components
- Output frequency represents the absolute sum of energy on all three phases
- Performs one, two or three phase power and energy measurement
- Meets the IEC 521/1036 Specification requirements for Class 1 AC Watt hour meters
- Operates over a wide temperature range
- Current transformers for sensing
- Excellent long term stability
- Easily adaptable to different signal levels
- Precision voltage reference on-chip
- Pin selectable pulse rates
- Supports tamper detection

DESCRIPTION

The SAMES SA9605A is an enhancement of the SA9105E and SA9105F, as no external capacitors are needed for the A/D converters.

The SAMES SA9605A Three Phase Power/Energy metering integrated circuit generates a pulse rate output, the frequency of which is proportional to the absolute power consumption. The SA9605A performs the calculation for active power.

The method of calculation takes the power factor into account.

Energy consumption is determined by the power measurement being integrated over time.

The output of this innovative universal three phase power/energy metering integrated circuit, is ideally suited for applications such as residential and industrial energy metering and control.

The SA9605A integrated circuit is available in both 20-pin dual-in-line plastic (DIP-20), as well as 20-pin plastic small outline (SOIC-20) package types.

PIN CONNECTIONS

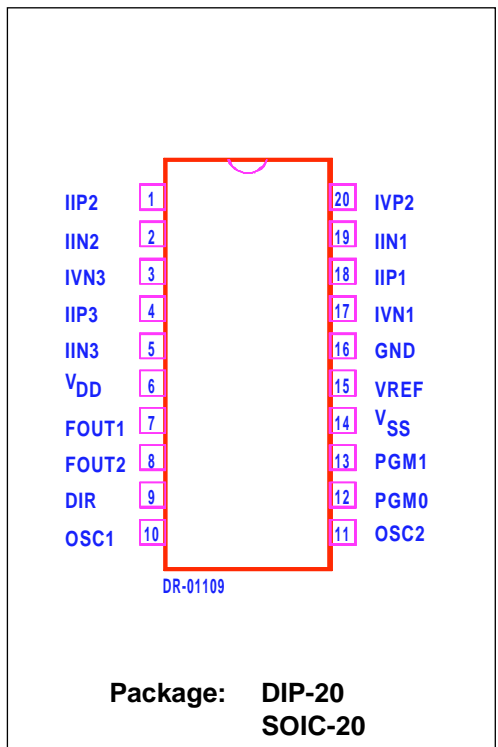

BLOCK DIAGRAM

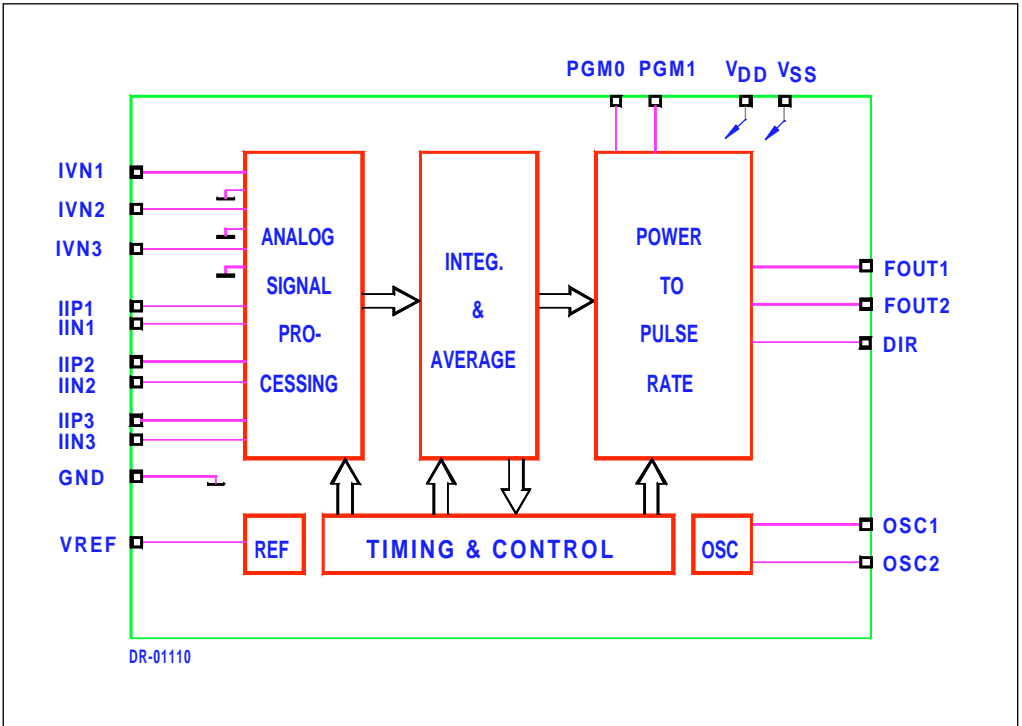

ABSOLUTE MAXIMUM RATINGS *

Parameter	Symbol	Min	Max	Unit
Supply Voltage	$V_{DD}-V_{SS}$	-0.3	6.0	V
Current on any Pin	I_{PIN}	-150	+150	mA
Storage Temperature	T_{STG}	-40	+125	°C
Operating Temperature	T_O	-40	+85	°C
Current at any pin	I_P	-100	+100	mA

* Stresses above those listed under "Absolute Maximum Ratings" may cause permanent damage to the device. This is a stress rating only. Functional operation of the device at these or any other conditions above those indicated in the operation sections of this specification, is not implied. Exposure to Absolute Maximum Ratings for extended periods may affect device reliability.

ELECTRICAL CHARACTERISTICS

($V_{DD} = 2.5V$, $V_{SS} = -2.5V$, over the temperature range $-10^{\circ}C$ to $+70^{\circ}C^{\#}$, unless otherwise specified.)

Parameter	Symbol	Min	Typ	Max	Unit	Condition
Operating Temperature Range #	T_O	-25		+85	$^{\circ}C$	
Supply Voltage	$V_{DD}-V_{SS}$	4.5		5.5	V	
Supply Current	I_{DD}			15	mA	
Nonlinearity of Power Calculation		-0.3		+0.3	%	1% - 100% of rated power
Current Sensor Inputs (Differential)						
Input Current Range	I_{II}	-25		+25	μA	Peak value
Voltage Sensor Inputs (Asymmetric)						
Input Current Range	I_{IV}	-25		+25	μA	Peak value
Pins FOUT1, FOUT2, DIR Output Low Voltage Output High Voltage	V_{OL} V_{OH}	$V_{DD}-1$		$V_{SS}+1$	V V	$I_{OL} = 5mA$ $I_{OH} = -2mA$
Pulse Rate: FOUT1	f_p	10		1160 3000	Hz Hz	Specified linearity Min and max limits
FOUT2						User selectable
Oscillator	Recommended crystal: TV colour burst crystal, $f = 3.5795$ MHz					
Pin VREF						With $R = 24$ k Ω
Ref. Current	$-I_R$	45	50	55	μA	connected to V_{SS}
Ref. Voltage	V_R	1.1		1.3	V	Referred to V_{SS}

Extended Operating Temperature Range available on request.



PIN DESCRIPTION

Pin	Designation	Description
16	GND	Ground
6	V _{DD}	Positive Supply Voltage
14	V _{SS}	Negative Supply Voltage
17	IVN1	Analog input for Voltage : Phase 1
20	IVN2	Analog input for Voltage : Phase 2
3	IVN3	Analog input for Voltage : Phase 3
19	IIN1	Inputs for Current sensor : Phase 1
18	IIP1	
2	IIN2	Inputs for Current sensor : Phase 2
1	IIP2	
5	IIN3	Inputs for Current sensor : Phase 3
4	IIP3	
10	OSC1	Connections for crystal or ceramic resonator
11	OSC2	(OSC1 = Input ; OSC2 = Output)
7	FOUT1	Pulse rate outputs
8	FOUT2	
9	DIR	Direction indicator
12	PGM0	FOUT2 Frequency select pins
13	PGM1	
15	VREF	Connection for current setting resistor

FUNCTIONAL DESCRIPTION

The SAMES SA9605A is a CMOS mixed signal Analog/Digital integrated circuit, which performs three phase power/energy calculations over a range of 1000:1, to an overall accuracy of better than Class 1.

The SA9605A in both DIP-20 and SOIC-20 package options is functionally similar to the SA9105E and SA9105F with the advantage of no external loop capacitors.

The integrated circuit includes all the required functions for 3-phase power and energy measurement such as oversampling A/D converters for the voltage and current sense inputs, power calculation and energy integration. Internal offsets are eliminated through the use of cancellation procedures.

The SA9605A generates pulses, the frequency of which is proportional to the power consumption. Two frequency outputs (FOUT1 and FOUT2) are available. The pulse rate follows the instantaneous power measured.

1. Power Calculation

In the Application Circuit (Figure 1), the mains voltages from Line 1, Line 2 and Line 3, are converted to currents and applied to the voltage sense inputs IVN1, IVN2 and IVN3.

The current levels on the voltage sense inputs are derived from the mains voltage (3 x 230 VAC) being divided down through voltage dividers to 14V. The resulting input currents into the A/D converters are 14 μ A through the resistors R₁₅, R₁₆ and R₁₇.

For the current sense inputs the voltage drop across the current transformers terminating resistors are converted to currents of 16 μ A for rated conditions, by means of resistors R₈, R₉ (Phase 1); R₁₀, R₁₁ (Phase 2); and R₁₂, R₁₃ (Phase 3).

The signals providing the current information are applied to the current sensor inputs: IIN1, IIP1; IIN2, IIP2; and IIN3, IIP3.

In this configuration, with the mains voltage of 3 x 230 V and rated currents of 80A, the output frequency of the SA9605A energy metering integrated circuit at FOUT1 is 1.16kHz. In this case 1 pulse will correspond to an energy consumption of 3 x 18.4 kW/1160Hz = 47.6 Ws.

The output frequency at FOUT1 and FOUT2 represents the absolute sum of the energy measured on all three phases, regardless of the direction of energy flow through the current sensors. This measurement method will assist meter manufacturers to circumvent meter tampering by reversal of the phases.

2. Analog Input Configuration

The current and voltage sensor inputs are illustrated below.

These inputs are protected against electrostatic discharge through clamping diodes, in conjunction with the amplifiers input configuration.

The feedback loops from the outputs of the amplifiers A_i and A_v generate virtual shorts on the signal inputs. Exact duplications of the input currents are generated for the analog processing circuitry.

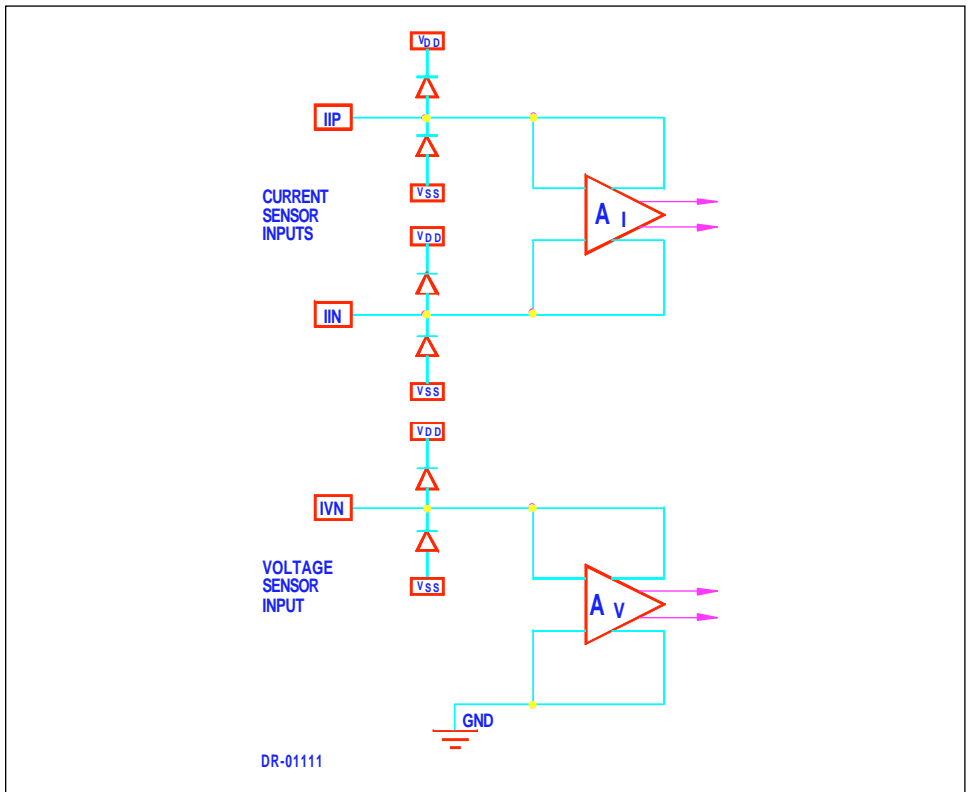

3. Electrostatic Discharge (ESD) Protection

The SA9605A integrated circuit's inputs/outputs are protected against ESD.

4. Power Consumption

The overall power consumption rating of the SA9605A integrated circuit is less than 75mW with a 5V supply.

5. Pulse Output Signals

Waveforms displaying the DIR and FOUT1 signal information for each of the three phases are shown below.

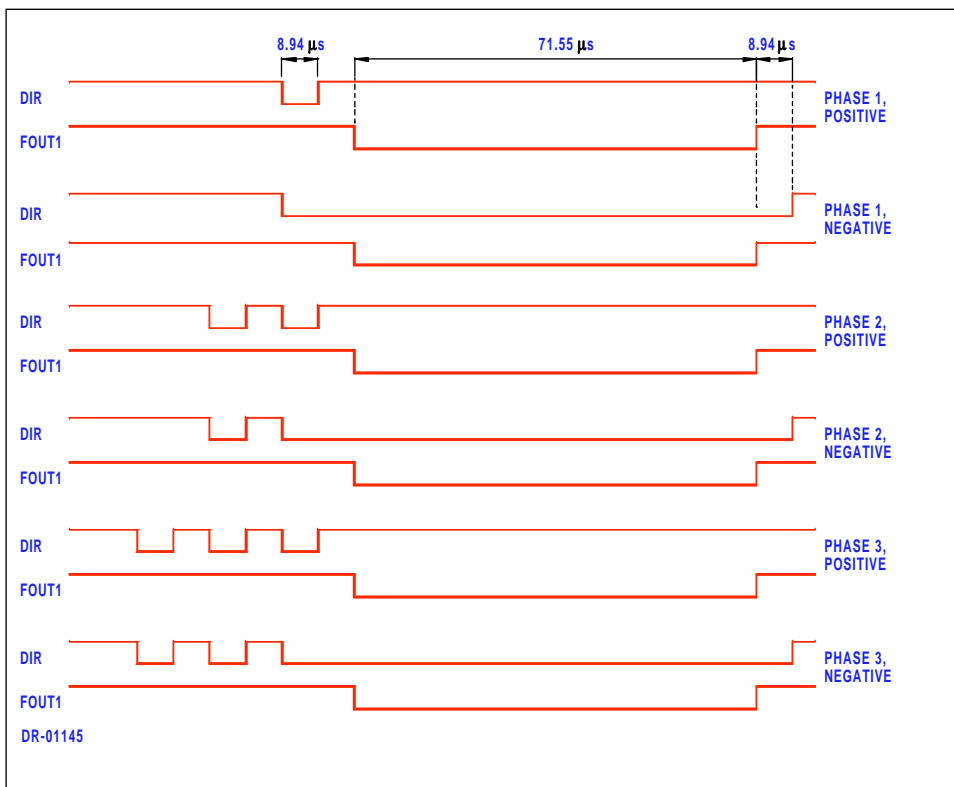

These waveforms demonstrate how to establish the direction of energy flow as well as the phase from which the energy is measured. The direction of energy indicated on pin DIR is HIGH for POSITIVE energy flow and LOW for NEGATIVE energy flow, for the entire LOW period of the FOUT1 pulse. The phase to which the direction indication on the DIR pin refers can be ascertained by counting the number of falling edges on the DIR pin prior to the falling edge of the FOUT1 pulse. The supervision of the DIR pin can be accomplished with a μ Controller.

Although FOUT1 has a fixed frequency output, the table below shows the various frequencies selectable for rated conditions on FOUT2.

User Selectable Output Frequency		
PGM1	PGM0	FOUT2 (Hz)
0	0	5.11
0	1	3.83
1	0	2.55
1	1	N/A

The frequencies shown in the above table were chosen to allow a 4 - 3 - 2 scaling ratio for rated conditions. This facility provides ease of interface with applications which use the same post divider with mechanical counter or unchanged microcontroller software for different current rated kWh meters.

For example, a meter manufacturer may wish to build meters for 3 system configurations with rated current loading of $80A_{RMS}$, $60A_{RMS}$ and $40A_{RMS}$. The rated line voltage is $230V_{RMS}$.

FOUT1 Frequency

Consider the case where FOUT1 is the output of the energy counting block. For each of the three rated conditions, the input current sensing resistors are chosen to ensure that $16\mu A_{RMS}$ flows into the current sensing pins.

Case 1 $I_L = 80A_{RMS}$

$$1 \text{ pulse on FOUT1} = \frac{80 * 230 * 3}{1160} = 47.6Ws$$

Case 2 $I_L = 60A_{RMS}$

$$1 \text{ pulse on FOUT1} = \frac{60 * 230 * 3}{1160} = 35.7Ws$$

Case 3 $I_L = 40A_{RMS}$

$$1 \text{ pulse on FOUT1} = \frac{40 * 230 * 3}{1160} = 23.8Ws$$

The amount of energy represented by one pulse for each of the three cases is different.

In addition to changing the current sensing resistor network, the energy counting block must also be altered.

FOUT2 Frequency

Now consider the advantage of the user selectable frequency available on FOUT2. Again the input current sensing resistors must be chosen to ensure that $16\mu A_{RMS}$ flows into the current sensing pins.

Case 1 $I_L = 80A_{RMS}$, PGM1 = 0 PGM0 = 0

$$1 \text{ pulse on FOUT2} = \frac{80 * 230 * 3}{5.11} = 10.8kWs$$

Case 2 $I_L = 60A_{RMS}$, PGM1 = 0 PGM0 = 1

$$1 \text{ pulse on FOUT2} = \frac{60 * 230 * 3}{3.83} = 10.8kWs$$

Case 3 $I_L = 40A_{RMS}$, PGM1 = 1 PGM0 = 0

$$1 \text{ pulse on FOUT2} = \frac{40 * 230 * 3}{2.55} = 10.8kWs$$



The only changes which now have to be implemented to interface the device to different rated systems are: change the current sense resistors; and select the required PGM0 and PGM1.

No change to the post divider or micro-controller software is required if the FOUT2 pin is used as described.

TYPICAL APPLICATION

In the Application Circuit (Figure 1), the components required for a three phase power metering application are shown.

Terminated current sensors (current transformers) are connected to the current sensor inputs of the SA9605A through current setting resistors ($R_8 \dots R_{13}$).

The resistor values for standard operation are selected for an input current of $16\mu\text{A}$ into the SA9605A, at the rated line current.

The values of these resistors are calculated as follows:

Phase 1:

$$R_8 = R_9 = (I_{L1}/16\mu\text{A}) * R_{18}/2$$

Phase 2:

$$R_{10} = R_{11} = (I_{L2}/16\mu\text{A}) * R_{19}/2$$

Phase 3:

$$R_{12} = R_{13} = (I_{L3}/16\mu\text{A}) * R_{20}/2$$

Where I_{LX} = Secondary CT current at rated conditions.

R_{18} , R_{19} and R_{20} = Current transformer termination resistors for the three phases.

$R_1 + R_{1A}$, R_4 and R_{15} set the current for the phase 1 voltage sense input. $R_2 + R_{2A}$, $R_5 + P_5$ and R_{16} set the current for phase 2 and $R_3 + R_{3A}$, $R_6 + P_6$ and R_{17} set the current for phase 3. The values should be selected so that the input currents into the voltage sense inputs (virtual ground) are set to $14\mu\text{A}$ for rated line voltage. Capacitors C1, C2 and C3 are for decoupling and phase compensation.

$R_{14} + P_{14}$ defines all on-chip bias and reference currents. With $R_{14} + P_{14} = 24\text{k}\Omega$, optimum conditions are set. $R_{14} + P_{14}$ may be varied within $\pm 10\%$ for calibration purposes. Any changes to $R_{14} + P_{14}$ will affect the output quadratically (i.e: $\Delta R = +5\%$, $\Delta f = +10\%$).

The formula for calculating the Output Frequency (f) is given below:

$$f = 11.16 * \text{FOUTX} * \frac{\text{FOSC}}{3.5795\text{MHz}} * \frac{(I_{11} I_{V1}) + (I_{12} I_{V2}) + (I_{13} I_{V3})}{3 * I_R^2}$$

Where FOUTX = Nominal rated frequency (1160Hz)

FOSC = Oscillator frequency (2MHz 4MHz)

I_{11} , I_{12} , I_{13} = Input currents for current inputs ($16\mu\text{A}$ at rated)

I_{V1} , I_{V2} , I_{V3} = Input currents for voltage inputs ($14\mu\text{A}$ at rated)

I_R = Reference current (typically $50\mu\text{A}$)



XTAL is a colour burst TV crystal ($f = 3.5795 \text{ MHz}$) for the oscillator. The oscillator frequency is divided down to 1.78975 MHz on-chip, to supply the digital circuitry and the A/D converters.

Figure 1: Application Circuit for Three Phase Power/Energy Measurement.

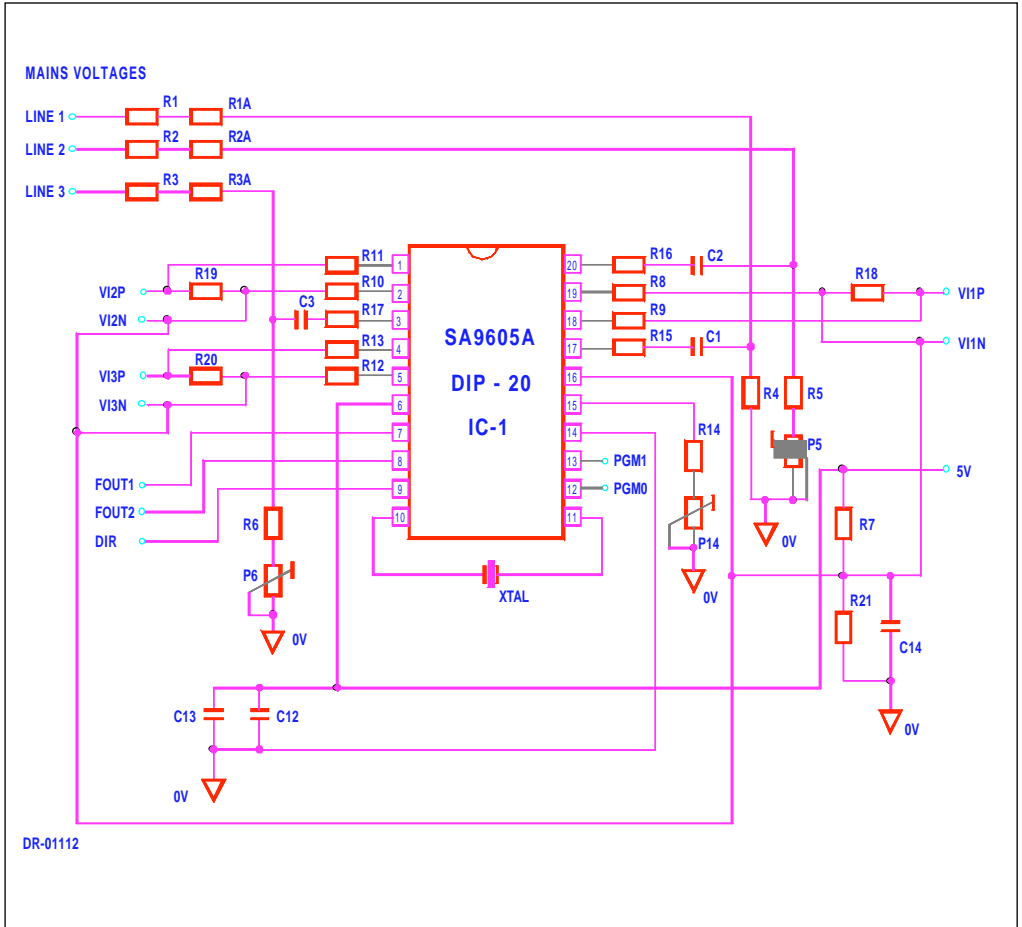

Parts List for Application Circuit: Figure 1

Item	Symbol	Description	Detail
1	IC-1	Integrated SA9605A	DIP-20, SOIC-20
2	XTAL	Crystal, 3.5795 MHz	Colour burst TV
3	R1	Resistor, 200k, 1%, ¼W	
4	R1A	Resistor, 180k, 1%, ¼W	
5	R2	Resistor, 200k, 1%, ¼W	
6	R2A	Resistor, 200k, 1%, ¼W	
7	R3	Resistor, 200k, 1% , ¼W	
8	R3A	Resistor, 180k, 1%, ¼W	
9	R4	Resistor, 24k, 1%, ¼W	
10	R5	Resistor, 22k, 1%, ¼W	
11	R6	Resistor, 22k, 1%, ¼W	
12	R7	Resistor, 820Ω, 1%, ¼W	
13	R8	Resistor	Note 1
14	R9	Resistor	Note 1
15	R10	Resistor	Note 1
16	R11	Resistor	Note 1
17	R12	Resistor	Note 1
18	R13	Resistor	Note 1
19	R14	Resistor, 22k, 1%, ¼W	
20	R15	Resistor, 1M, 1%, ¼W	
21	R16	Resistor, 1M, 1%, ¼W	
22	R17	Resistor, 1M, 1%, ¼W	
23	R18	Resistor	Note 1
24	R19	Resistor	Note 1
25	R20	Resistor	Note 1
26	R21	Resistor, 820Ω, 1%, ¼W	
27	P5	Potentiometer, 4.7k	Multi turn
28	P6	Potentiometer, 4.7k	Multi turn
29	P14	Potentiometer, 4.7k	Multi turn
30	C1	Capacitor, electrolytic, 1μF, 6V	Note 2
31	C2	Capacitor, electrolytic, 1μF, 6V	Note 2
32	C3	Capacitor, electrolytic, 1μF, 6V	Note 2
33	C12	Capacitor, 820nF	Note 3
34	C13	Capacitor, 100nF	
35	C14	Capacitor, 100nF	

SA9605A

- Note 1: Resistor (R_8 , R_9 , R_{10} , R_{11} , R_{12} and R_{13}) values are dependant upon the selected values of the current transformer termination resistors R_{18} , R_{19} and R_{20} .
- Note 2: Capacitor values may be selected to compensate for phase errors caused by the current transformers.
- Note 3: Capacitor (C12) to be positioned as close to Supply Pins (V_{DD} & V_{SS}) of IC-1, as possible.

ORDERING INFORMATION

Part Number	Package
SA9605APA	DIP-20
SA9605ASA	SOIC-20



NOTES:



Disclaimer: The information contained in this document is confidential and proprietary to South African Micro-Electronic Systems (Pty) Ltd ("SAMES") and may not be copied or disclosed to a third party, in whole or in part, without the express written consent of SAMES. The information contained herein is current as of the date of publication; however, delivery of this document shall not under any circumstances create any implication that the information contained herein is correct as of any time subsequent to such date. SAMES does not undertake to inform any recipient of this document of any changes in the information contained herein, and SAMES expressly reserves the right to make changes in such information, without notification, even if such changes would render information contained herein inaccurate or incomplete. SAMES makes no representation or warranty that any circuit designed by reference to the information contained herein, will function without errors and as intended by the designer.

Any Sales or technical questions may be posted to our e-mail address below:
energy@sames.co.za

For the latest updates on datasheets, please visit our web site:
<http://www.sames.co.za>

South African Micro-Electronic Systems (Pty) Ltd

P O Box 15888,
Lynn East,
0039
Republic of South Africa,

33 Eland Street,
Koedoespoort Industrial Area,
Pretoria,
Republic of South Africa

Tel: 012 333-6021
Fax: 012 333-8071

Tel: Int +27 12 333-6021
Fax: Int +27 12 333-8071