

THREE PHASE BIDIRECTIONAL POWER/ENERGY METERING IC WITH SERIAL SPI INTERFACE

FEATURES

- Performs bidirectional active and reactive power/energy measurement
- Voltage and frequency measurement
- Individual phase information accessible
- SPI communication bus
- Meets the IEC 521/1036 Specification requirements for Class 1 AC Watt hour meters
- Protected against ESD
- Uses current transformers for current sensing
- Excellent long term stability
- Operates over a wide temperature range
- Precision Voltage Reference on-chip

DESCRIPTION

The SAMES SA9604A Bidirectional Three Phase Power/Energy metering integrated circuit has a serial interface, ideal for use with a μ -Controller. The SA9604A performs the calculation for active and reactive power or energy, mains voltage sense and frequency.

The measurements performed and the resultant register values are provided for individual phases.

The integrated values for active and reactive energy, as well as the mains voltage sense and frequency information, are accessible through the SPI as 24 bit values.

This innovative universal three phase power/energy metering integrated circuit is ideally suited for energy calculations in applications such as primary industrial metering and factory energy metering and control.

The SA9604A integrated circuit is available in both 20 pin dual-in-line plastic (DIP-20), as well as 20 pin small outline (SOIC-20) package types.

PIN CONNECTIONS

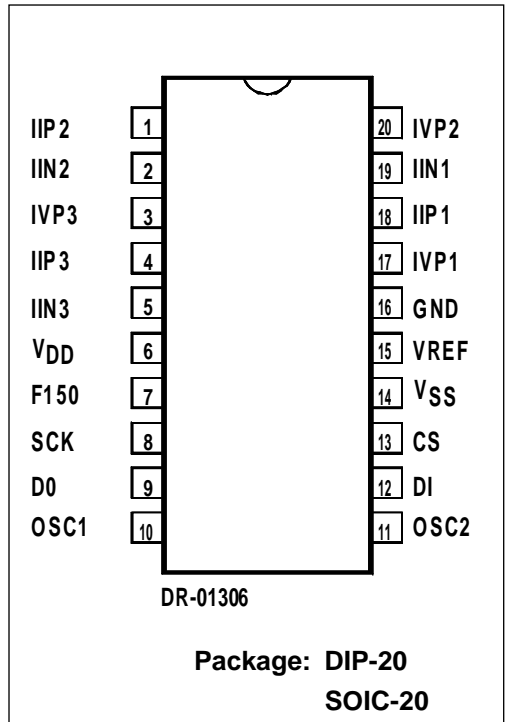

BLOCK DIAGRAM

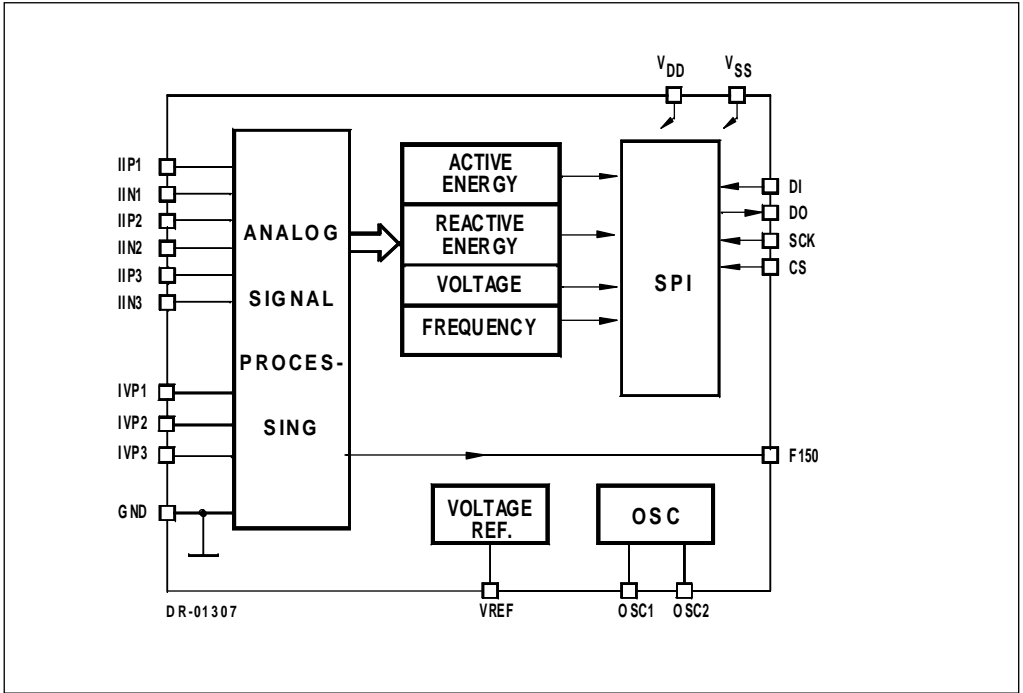

ABSOLUTE MAXIMUM RATINGS*

Parameter	Symbol	Min	Max	Unit
Supply Voltage	$V_{DD} - V_{SS}$	-0.3	6.0	V
Current on any pin	I_{PIN}	-150	+150	mA
Storage Temperature	T_{STG}	-40	+125	°C
Operating Temperature	T_O	-40	+85	°C

* Stresses above those listed under "Absolute Maximum Ratings" may cause permanent damage to the device. This is a stress rating only. Functional operation of the device at these or any other condition above those indicated in the operational sections of this specification, is not implied. Exposure to Absolute Maximum Ratings for extended periods may affect device reliability.

ELECTRICAL CHARACTERISTICS

($V_{DD} = 2.5V$, $V_{SS} = -2.5V$, over the temperature range $-10^{\circ}C$ to $+70^{\circ}C^{\#}$, unless otherwise specified.)

Parameter	Symbol	Min	Typ	Max	Unit	Condition
Operating temp. range	T_O	-25		+85	$^{\circ}C$	
Supply Voltage: Positive	V_{DD}	2.25		2.75	V	
Supply Voltage: Negative	V_{SS}	-2.75		-2.25	V	
Supply Current: Positive	I_{DD}		8	10	mA	
Supply Current: Negative	I_{SS}		8	10	mA	
Current Sensor Inputs (Differential)						
Input Current Range	I_{II}	-25		+25	μA	Peak value
Voltage Sensor Input (Asymmetrical)						
Input Current Range	I_{IV}	-25		+25	μA	Peak value
Pin DO						
Low Voltage	V_{OL}			$V_{SS}+1$	V	$I_{OL} = 5mA$
High Voltage	V_{OH}	$V_{DD}-1$			V	$I_{OH} = -2mA$
Pin DI						
High Voltage	V_{IH}	$V_{DD}-1$			V	
Low Voltage	V_{IL}			$V_{SS}+1$	V	$V_{IN} = V_{SS}$
Pin SCK						
High Voltage	V_{IH}	$V_{DD}-1$			V	
Low Voltage	V_{IL}			$V_{SS}+1$	V	$V_{IN} = V_{SS}$
	f_{SCK}			800	kHz	
	t_{LO}	0.6			μs	
	t_{HI}	0.6			μs	
Pin CS						
High Voltage	V_{IH}	$V_{DD}-1$			V	
Low Voltage	V_{IL}			$V_{SS}+1$	V	$V_{IN} = V_{SS}$
Pin F150						
Low Voltage	V_{OL}			$V_{SS}+1$	V	$I_{OL} = 5mA$
High Voltage	V_{OH}	$V_{DD}-1$			V	$I_{OH} = -2mA$
Oscillator	Recommended crystal: TV colour burst crystal $f = 3.5795$ MHz					
Pin VREF						
Ref. Current	$-I_R$	22.5	25	27.5	μA	With $R = 47k\Omega$ connected to V_{SS} Reference to V_{SS}
Ref. Voltage	V_R	1.1		1.3	V	

$\#$ Extended Operating Temperature Range available on request.

PIN DESCRIPTION

Pin	Designation	Description
16	GND	Ground
6	V _{DD}	Positive Supply Voltage
14	V _{SS}	Negative Supply Voltage
17	IVP1	Analog input for Voltage: Phase 1
20	IVP2	Analog input for Voltage: Phase 2
3	IVP3	Analog input for Voltage: Phase 3
19	IIN1	Inputs for Current sensor:Phase 1
18	IIP1	
2	IIN2	Input for Current sensor: Phase 2
1	IIP2	
5	IIN3	Input for Current sensor: Phase 3
4	IIP3	
10	OSC1	Connections for crystal or ceramic resonator (OSC1 = Input; OSC2 = Output)
11	OSC2	
9	DO	Serial Interface Out
12	DI	Serial Interface In
8	SCK	Serial Clock In
13	CS	Chip Select (Active High)
7	FM150	Voltage Sense Zero Crossover
15	VREF	Connection for current setting resistor

FUNCTIONAL DESCRIPTION

The SA9604A is a CMOS mixed signal Analog/Digital Integrated Circuit, which performs the measurement of active power, reactive power, voltage and frequency.

Internal offsets are eliminated through the use of cancellation procedures. The SA9604A integrates the measured active and reactive power consumption and the average mains voltage into 24 bit integrators, which are accessible via the SPI bus. The mains frequency information is also available as a 24 bit register value.

The zero crossover of each voltage sense input is signalled on the FM150 (pin 7) output. This output of 150Hz will allow monitoring by a microcontroller to synchronise with internal timing for data acquisition. Refer to 5.5 for further information.

The SA9604A has tristate output to allow connection of more than one metering device on a single SPI bus.

1. Power calculation

In the Application Circuit (Figure 1), the voltages from Line 1, Line 2 and Line 3, are converted to currents and applied to the voltage sense inputs IVN1, IVN2 and IVN3.

The current levels on the voltage sense inputs are derived from the mains voltage ($3 \times 230 V_{AC}$) being divided down through voltage dividers to $14V_{RMS}$. The resulting input currents into the A/D converters are $14\mu A_{RMS}$ through the resistors R_{15} , R_{16} and R_{17} .

For the current sense inputs, the voltages across the current transformers terminating resistors are converted to currents of $16\mu A_{RMS}$ for rated conditions, by means of resistors R_8 , R_9 (Phase 1); R_{10} , R_{11} (Phase 2); and R_{12} , R_{13} (Phase 3).

The signals providing the current information are applied to the current sensor inputs: IIN1; IIP1; IIN2; IIP2; IIN3; and IIP3.

2. Analog Input Configuration

The input circuitry of the current and voltage sensor inputs are illustrated below.

These inputs are protected against electrostatic discharge through clamping diodes.

The feedback loops from the outputs of the amplifiers A_I and A_V generate virtual shorts on the signal inputs. Exact copies of the input currents are generated for the following analog signal processing circuitry.

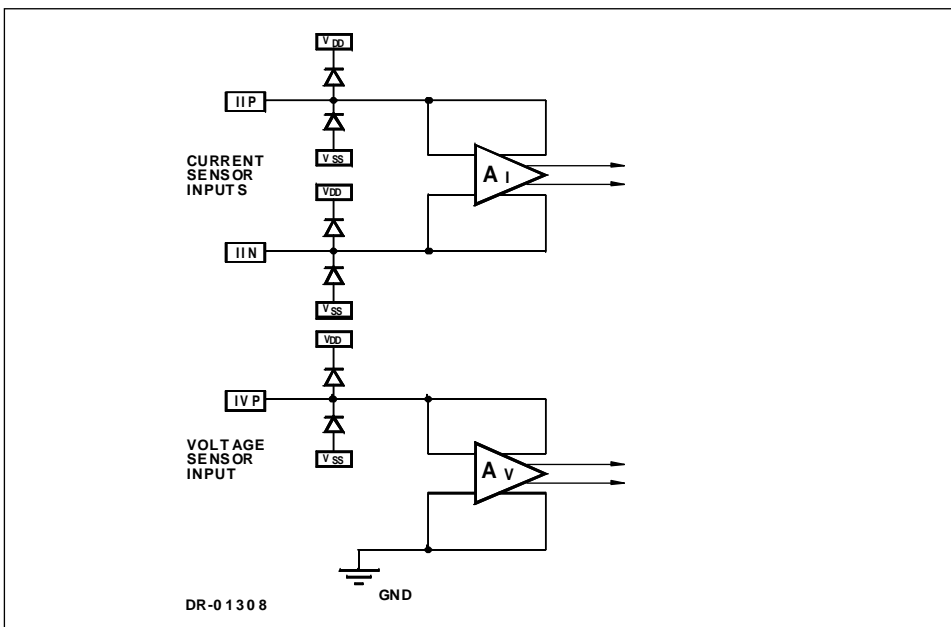

3. Electrostatic Discharge (ESD), Protection

The SA9604A Integrated Circuits inputs/outputs are protected against ESD.

4. Power Consumption

The power consumption rating of the SA9604A integrated circuit is less than 50mW.

5. SPI - INTERFACE**5.1 Description**

The serial peripheral interface (SPI) is a synchronous bus for data transfer and is used when interfacing the SA9604A with any micro-controller. Four pins are used for the SPI. The four pins are DO (Serial Data Out), DI (Serial Data In), CE (Chip Enable), and SCK (Serial Clock). The SA9604A is the slave device in an SPI application, with the micro-controller being the master. The DI and DO pins are the serial data input and output pins for the SA9604A, respectively. The CE input is used to initiate and terminate a data transfer. The SCK pin is used to synchronize data movement between the master (micro-controller) and the slave (SA9604A) devices.

The serial clock (SCK), which is generated by the micro-controller, is active only during address and data transfer to any device on the SPI bus.

5.2 Register Access

There are four registers for each phase which can be read: active, reactive, voltage and frequency. Any of these registers may be chosen as the initial register to read. If the SCK clock input continues after the first register has been read, the contents of subsequent registers will be output on the DO pin. Transfer will continue until CS is brought inactive.

To enable registers for reading, the sequence 1 1 0 (6_{HEX}) must precede the 6 bit address of the register being accessed.

The various register addresses are shown in the table below:

ID	REGISTER	A5	A4	A3	A2	A1	A0
1	Active: Phase 1	X	X	0	0	0	0
2	Reactive: Phase 1	X	X	0	0	0	1
3	Voltage: Phase 1	X	X	0	0	1	0
4	Frequency: Phase 1	X	X	0	0	1	1
5	Active: Phase 2	X	X	0	1	0	0
6	Reactive: Phase 2	X	X	0	1	0	1
7	Voltage: Phase 2	X	X	0	1	1	0
8	Frequency: Phase 2	X	X	0	1	1	1
9	Active: Phase 3	X	X	1	0	0	0
10	Reactive: Phase 3	X	X	1	0	0	1
11	Voltage: Phase 3	X	X	1	0	1	0
12	Frequency: Phase 3	X	X	1	0	1	1

Address locations A4 and A5 have been included to ensure compatibility with future SAMES integrated circuit developments.

When CS is high, data input on pin DI is clocked into the device on the rising edge of SCK. The data clocked into DI will comprise of 1 1 0 A5 A4 A3 A2 A1 A0, in this order.

5.3 Data Output

After the least significant digit of the address has been entered on the rising edge of SCK, the output DO goes low with falling edge of SCK. Each subsequent falling edge transaction on the SCK pin will validate data of the register contents on pin DO.

The contents of each register consists of 24 bits of data output on pin D0, starting with the most significant digit, D23.

5.4 Frequency Register

For the frequency register only bits D15 ... D0 are used for calculations. The upper seven bits (D23 ... D17) must still be clocked out, as important frequency information can be derived from these data bits.

Bit D17 changes with every rising edge of the mains voltage (25Hz square wave for 50Hz mains system). Bit D18 displays a frequency of D17/2 and D19 displays a frequency of D17/4.

The phase error status may be ascertained from bits D20 and D21. The table below may be used for this purpose:

Frequency data Bits		Description
D21	D20	
0	0	No phase error
1	0	Phase sequence error (2 phase swapped)
1	1	Missing phase

The phase error status is merged on all three frequency registers.

Bits D16, D22 and D23 are not used.

5.5 SPI Waveforms

The read cycle waveforms are shown below:

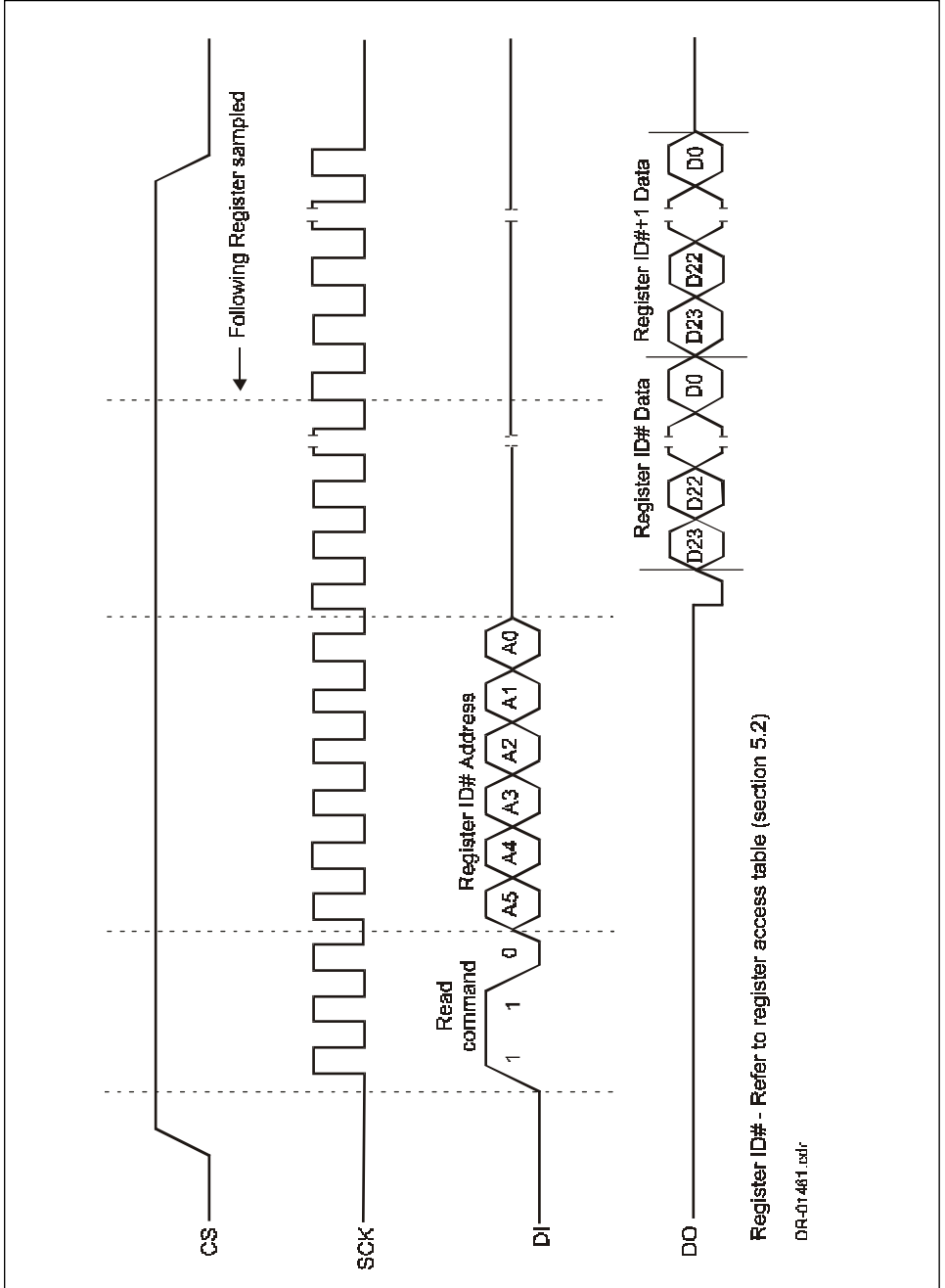

Register ID# - Refer to register access table (section 5.2)

DR-01481.pdf

SPI TIMING

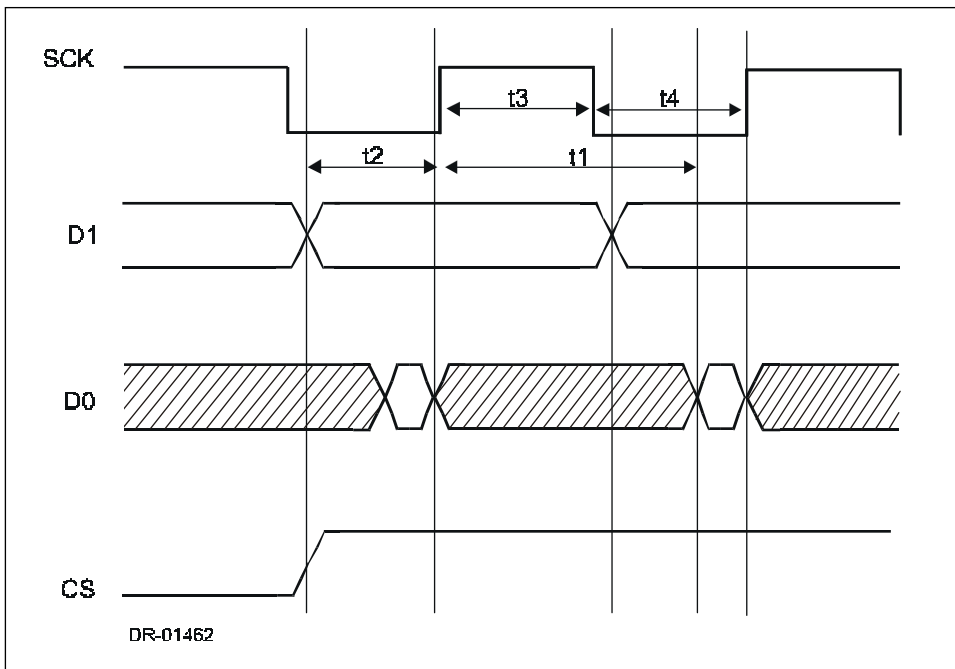

Parameter	Description	Min	Max	Unit
t1	SCK rising edge for data valid		1,160	μS
t2	Setup time for DI and CS before the rising edge of SCK	0,560		μS
t3	SCK min high time	0,625		μS
t4	SCK min low time	0,625		μS

5.6 Synchronised Reading of Registers

The SA9604A integrated circuit updates the registers on a continual basis. The SA9604A register content is latched onto the SPI interface as soon as a read command has been detected or the next register is addressed during continual access. The registers can be accessed at any time however for maximum stability the time between readings must be in multiples of 8 mains cycles. The internal offset cancellation procedure requires 8 mains cycles to complete. The registers are not reset after access, so in order to determine the correct register value the previous value read must be subtracted from the current reading. This methodology holds true for Active, Reactive and Voltage registers. The data read from the registers

represents the active power, reactive power and voltage integrated over time. The increase or decrease between readings is the energy consumption. The registers are not affected during access. No error is possible during read, because all control signals are generated on chip. The registers can be accessed in any sequence at any time without problems.

The voltage sense zero crossing is a 1mS pulse available on FM150, (Pin 7). This information allows a supervisor (ie: microcontroller) to monitor when the next read operation should be performed. The FM150 output is only suitable if all phase voltages are connected. Should one or more phases fail the FM150 output becomes unstable. A better approach would be to monitor the upper bits of the frequency register (18, 19). A measurement cycle is completed when these bits change to the same state again (00..00 or 01..01 or 10..10 or 11..11).

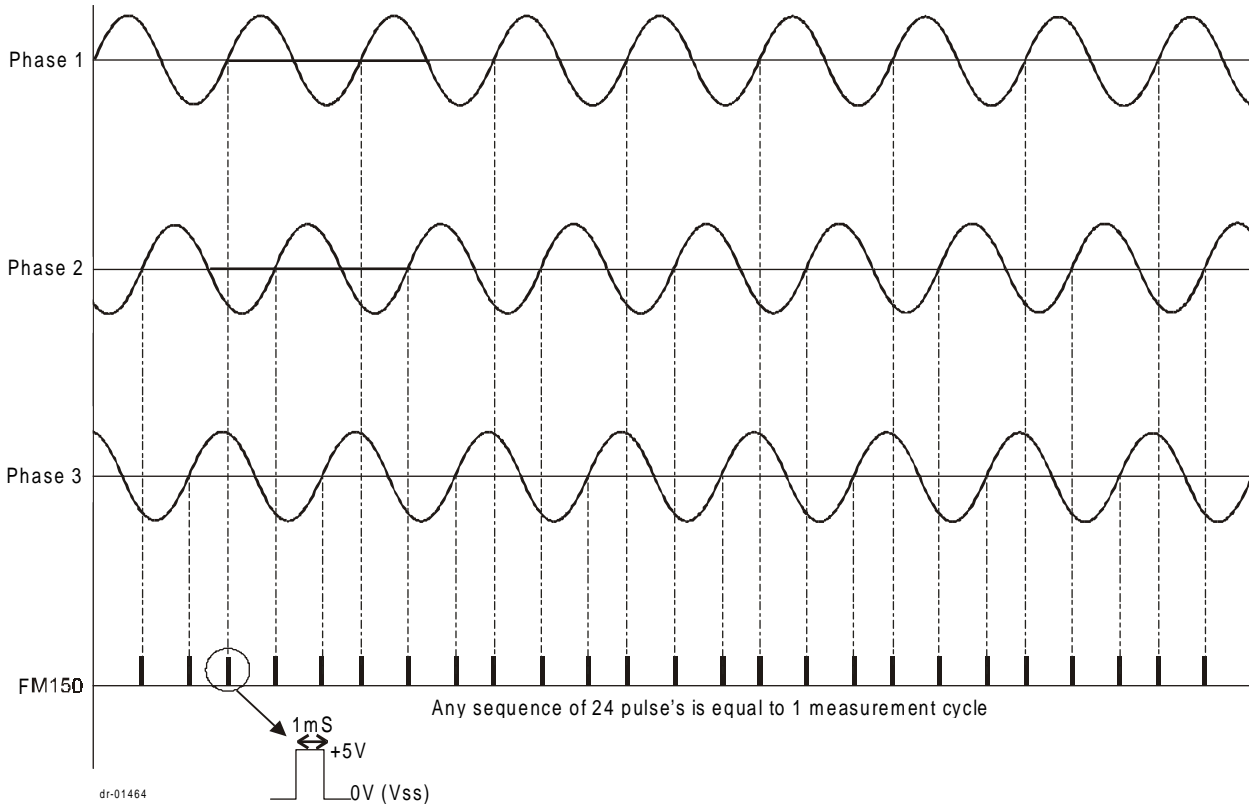

6. Register Values

The 24 bit registers are up/down counters, which increment or decrement at a rate of 640k/s ($640k \cdot 2/\text{PI}$ for reactive) at rated conditions. The energy register values will increment for positive energy flow and decrement for negative energy flow as can be seen in the following diagram:

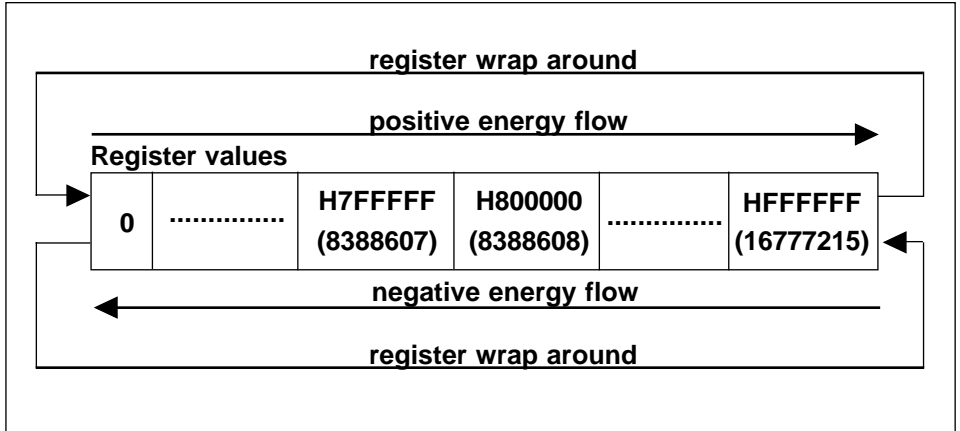

At power-up the register values are underfined and for this reason the msb of the **delta value** (delta value = present register value - previous register value) should be regarded as an indication of the measured energy direction. (0 = positive, 1 = negative).

The **delta value** for the energy registers is between 0 and 8388607 for positive energy flow and between 0 and -8388607 for negative energy flow. For voltage the maximum usable delta value is 16777215 as voltage is in a positive direction only.

When reading the registers care should be taken to check for a wrap around condition.

As an example lets assume that with a constant load connected the delta value is 22260. Because of the constant load, the delta value should always be 22260 every time the register is read and the previous value subtracted (assuming the same time

period between reads). However this will not be true when a wrap around occurs as the following example will demonstrate:

```

Previous register value    =      16744955
Present register value    =      16767215
Delta value                =      16767215 - 16744955 = 22260

```

After the next read the values are as follows:

```

Previous register value    =      16767215
Present register value    =      12260
Delta value                =      12260 - 16767215 = -16754955

```

Computing this delta value will result in incorrect readings, in other words a wrap around has occurred. A typical function to check for wrap around condition would be as follows:

```
Function Check (delta_value);
```

```
Begin
```

```
Temp_delta_value = abs(delta_value);    {get rid of the minus sign for example:
                                         abs(-151) = 151}
```

```
if Temp_delta_value > 8388607 then
```

```
begin
```

```
if (delta_value) > 0 then result := (16777216 - delta_value) * -1
```

```
else result := (16777216 + delta_value);
```

```
end;
```

```
end; {end function}
```

At rated conditions, the time for wrap around is as follows:

18.6 seconds for voltage

13 seconds for active and 21 seconds for reactive

The active and reactive energy measured per count, may be calculated by applying the following formula:

$$\text{Energy per Count} = \frac{VI}{K} \text{ Watt seconds}$$

Where V = Rated Voltage

I = Current (I_{\max})

K = 640 000 for Active Energy

$\frac{640\,000 * 2}{\pi}$ for Reactive Energy

Example:

$$V = 230V$$

$$I = 80A$$

$$\text{Active Power} = 230V \times 80A \times (n/t)/640000$$

$$\text{Reactive Power} = 230V \times 80A \times (n/t)/(640000 \times 2)/\text{Pi}$$

n = Difference in register values between successive reads (delta value)

t = Time difference between successive reads (in seconds)

To calculate the measured voltage, the following formula is applied:

$$V_{\text{measured}} = \frac{V * n}{940\,000 * t}$$

Where V = Rated Voltage

t = Time difference between successive reads

n = Difference in register values between successive reads

The Voltage calculated is the average voltage. The voltage measurement will give an accuracy of better than 1% for a voltage range of 50% to 115% of the rated mains voltage if the voltage is a pure sine wave.

The mains frequency may be calculated as follows:

$$\text{Frequency} = \frac{\text{Crystal frequency}}{\text{Register Value} * 2}$$

7. Calibration

For accurate results we would recommend the following software calibration procedure:

7.1 Active energy

Establish a calibration factor for active energy (Ka) at pf close to 1.

$$\text{Active Measured} = \text{Active_Register_Value} \times \text{Ka}$$

7.2 Reactive Energy

With a pf close to 0 establish the phase error:

$$\text{PhaseError} = \arctan (\text{VARMeasured} / \text{ActiveMeasured})$$

For **each measurement** calculate the following:

$$\begin{aligned} \text{VA} &= \sqrt{\text{ActiveMeasured}^2 + \text{VARmeasured}^2} \\ \text{PHIcalibrated} &= \arctan (\text{VARmeasured} / \text{ActiveMeasured}) \\ \text{PHICorrected} &= \text{PHIcalibrated} - \text{PhaseError} \\ \text{VARtrue} &= \text{VA} * \sin(\text{PHICorrected}) \end{aligned}$$

TYPICAL APPLICATION

In the Application Circuit (Figure 1), the components required for a three phase energy metering application are shown.

Terminated current sensors (current transformers) are connected to the current sensor inputs of the SA9604A through current setting resistors ($R_8 \dots R_{13}$).

The resistor values for standard operation are selected for an input current of $16\mu\text{A}_{\text{RMS}}$ into the SA9604A, at the rated line current.

The values of these resistors are calculated as follows:

Phase 1:

$$R_8 = R_9 = (I_{L1} / 16\mu\text{A}_{\text{RMS}}) * R_{18} / 2$$

Phase 2:

$$R_{10} = R_{11} = (I_{L2} / 16\mu\text{A}_{\text{RMS}}) * R_{19} / 2$$

Phase 3:

$$R_{12} = R_{13} = (I_{L3} / 16\mu\text{A}_{\text{RMS}}) * R_{20} / 2$$

Where I_{Lx} = Secondary CT current at rated conditions.

R_{18} , R_{19} and R_{20} = Current transformer termination resistors for the three phases.

$R_1 + R_{1A}$, R_4 and R_{15} set the current for the phase 1 voltage sense input. $R_2 + R_{2A}$, $R_5 + R_5$ and R_{16} set the current for phase 2 and $R_3 + R_{3A}$, R_6 and R_{17} set the current for phase 3. The values should be selected so that the input currents into the voltage sense inputs (virtual ground) are set to $14\mu\text{A}_{\text{RMS}}$ for the rated line voltage condition. Capacitors C1, C2 and C3 are for decoupling and phase compensation.

R_{14} defines all on-chip bias and reference currents. With $R_{14} = 47\text{k}\Omega$, optimum conditions are set. R_{14} may be varied by up to $\pm 10\%$ for calibration purposes. Any changes to R_{14} will affect the output quadratically (i.e: $\Delta R = +5\%$, $\Delta P = +10\%$).

XTAL is a colour burst TV crystal ($f = 3.5795 \text{ MHz}$) for the oscillator. The oscillator frequency is divided down to 1.78975 MHz on-chip, to supply the digital circuitry and the A/D converters.

Figure 1: Application Circuit for Three Phase Power/Energy Measurement

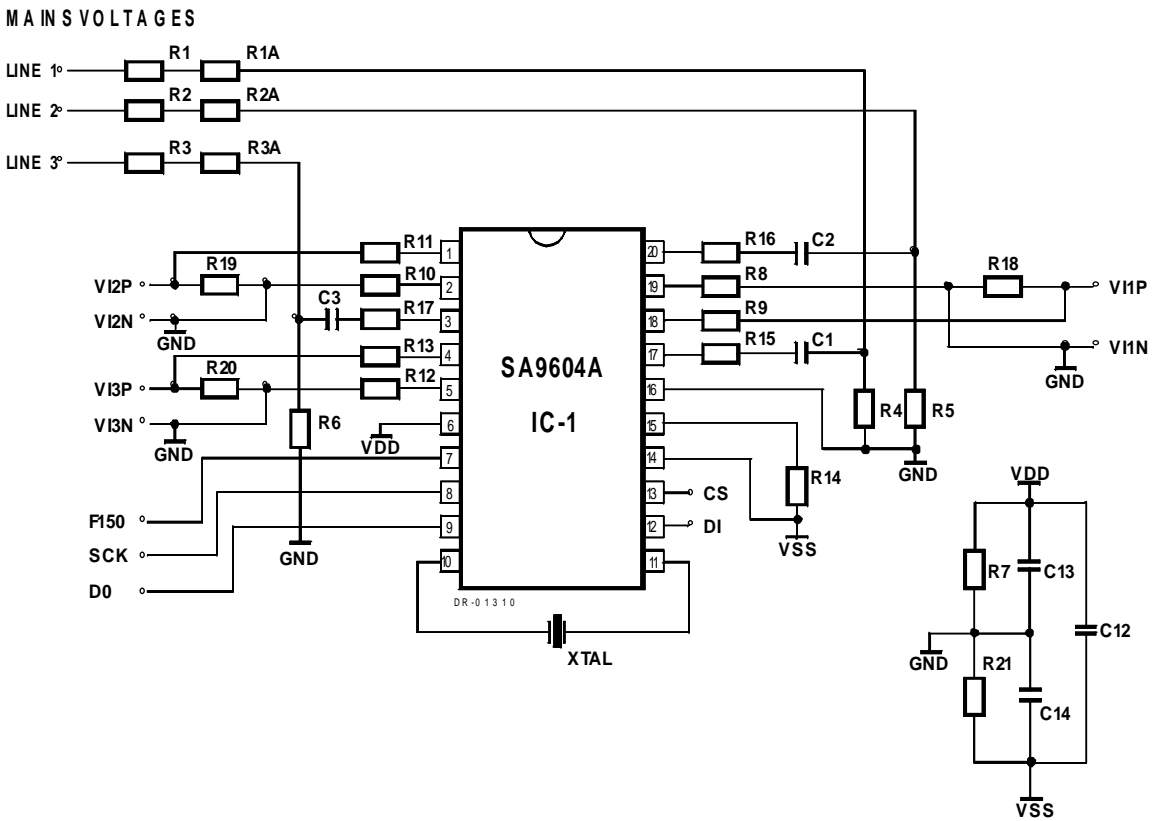

Parts List for Application Circuit: Figure 1

Item	Symbol	Description	Detail
1	IC-1	Integrated circuit, SA9604A	DIP-20, SOIC-20
2	XTAL	Crystal, 3.5795 MHz	Colour burst TV
3	R1	Resistor, 200k, 1%, ¼W	
4	R1A	Resistor, 180k, 1%, ¼W	
5	R2	Resistor, 200k, 1%, ¼W	
6	R2A	Resistor, 200k, 1%, ¼W	
7	R3	Resistor, 200k, 1% , ¼W	
8	R3A	Resistor, 180k, 1%, ¼W	
9	R4	Resistor, 24k, 1%, ¼W	
10	R5	Resistor, 24k, 1%, ¼W	
11	R6	Resistor, 24k, 1%, ¼W	
12	R7	Resistor, 820Ω, 1%, ¼W	
13	R8	Resistor	Note 1
14	R9	Resistor	Note 1
15	R10	Resistor	Note 1
16	R11	Resistor	Note 1
17	R12	Resistor	Note 1
18	R13	Resistor	Note 1
19	R14	Resistor, 47k, 1%, ¼W	
20	R15	Resistor, 1M, 1%, ¼W	
21	R16	Resistor, 1M, 1%, ¼W	
22	R17	Resistor, 1M, 1%, ¼W	
23	R18	Resistor	Note 1
24	R19	Resistor	Note 1
25	R20	Resistor	Note 1
26	R21	Resistor, 820Ω, 1%, ¼W	
27	C1	Capacitor, electrolytic, 1μF, 6V	Note 2
28	C2	Capacitor, electrolytic, 1μF, 6V	Note 2
29	C3	Capacitor, electrolytic, 1μF, 6V	Note 2
30	C12	Capacitor, 820nF	Note 3
31	C13	Capacitor, 100nF	
32	C14	Capacitor, 100nF	

- Note 1: Resistor (R_8 , R_9 , R_{10} , R_{11} , R_{12} and R_{13}) values are dependant upon the selected value of the current transformer termination resistors R_{18} , R_{19} and R_{20} .
- Note 2: Capacitor values may be selected to compensate for phase errors caused by the current transformers.
- Note 3: Capacitor (C12) to be positioned as close to Supply Pins (V_{DD} & V_{SS}) of IC-1, as possible

ORDERING INFORMATION

Part Number	Package
SA9604APA	DIP-20
SA9604ASA	SOIC-20

Notes:

Disclaimer: The information contained in this document is confidential and proprietary to South African Micro-Electronic Systems (Pty) Ltd ("SAMES") and may not be copied or disclosed to a third party, in whole or in part, without the express written consent of SAMES. The information contained herein is current as of the date of publication; however, delivery of this document shall not under any circumstances create any implication that the information contained herein is correct as of any time subsequent to such date. SAMES does not undertake to inform any recipient of this document of any changes in the information contained herein, and SAMES expressly reserves the right to make changes in such information, without notification, even if such changes would render information contained herein inaccurate or incomplete. SAMES makes no representation or warranty that any circuit designed by reference to the information contained herein, will function without errors and as intended by the designer.

Any sales or technical questions may be posted to our e-mail address below:
energy@sames.co.za

For the latest updates on datasheets, please visit our web site:
<http://www.sames.co.za>

South African Micro-Electronic Systems (Pty) Ltd

P O Box 15888,

Lynn East,

0039

Republic of South Africa,

33 Eland Street,

Koedoespoort Industrial Area,

Pretoria,

Republic of South Africa

Tel: 012 333-6021

Fax: 012 333-8071

Tel: Int +27 12 333-6021

Fax: Int +27 12 333-8071

