

Programmable Single Phase Energy Metering IC with Tamper Detection



sames

SA9607P

FEATURES

- Provides direct interface to mechanical counters
- Calibration and setup stored on external EEPROM - no trim pots required
- Monitors both Live and Neutral for tamper detection
- Performs bidirectional energy measurement
- Flexible programmable features
- Meets the IEC 521/1036 Specification for Class 1 AC Watt hour meters
- Total power consumption rating below 25mW
- Adaptable to different types of sensors
- Operates over a wide temperature range
- Precision voltage reference on chip.

DESCRIPTION

The SAMES SA9607P is a single-phase bidirectional energy metering integrated circuit. It provides a cost effective solution for energy meters with electro-mechanical displays, such as stepper motors and impulse counters.

Two current sensor inputs allow the measurement of energy consumption on both the live and neutral lines.

Direction detection of energy flow as well as other common tamper conditions are flagged.

The power consumption on both the live and neutral are

continuously measured and the larger of the two is selected for energy metering.

The SA9607P drives the calibration LED and the electro-mechanical counter directly.

The SA9607P does not require any external trim-pots. All required calibration and configuration data is read from a small external EEPROM.

The SA9607P integrated circuit is available in 20 pin dual-in-line plastic (DIP-20) and small outline (SOIC-20) package types.

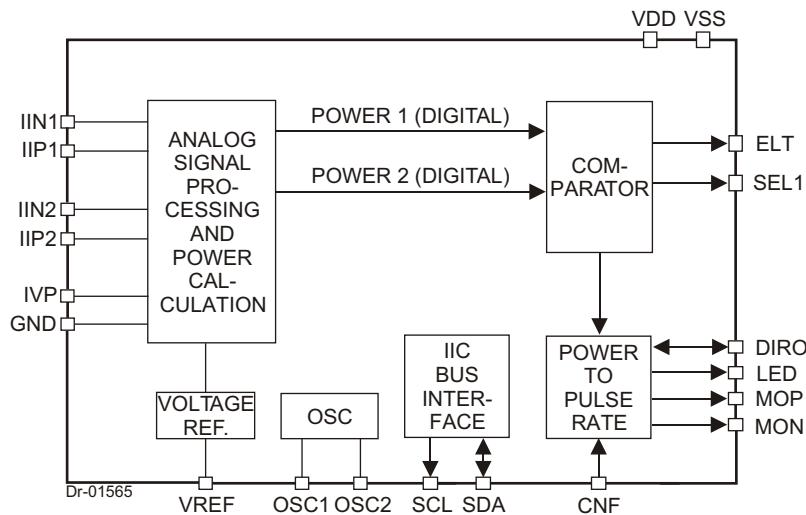

Figure 1: Block diagram

**ELECTRICAL CHARACTERISTICS**(V_{DD} = 2.5V, V_{SS} = -2.5V, over the temperature range -10°C to +70°C#, unless otherwise specified.)

| Parameter | Symbol | Min | Typ | Max | Unit | Condition |
|---------------------------------------------------------------------|------------------------------------|--------------------|-----|--------------------|---------|-------------------------------------------------------------------------------|
| Operating temp. Range | T _O | -25 | | +85 | °C | |
| Supply Voltage: Positive | V _{DD} | 2.25 | | 2.75 | V | |
| Supply Voltage: Negative | V _{SS} | -2.75 | | -2.25 | V | |
| Supply Current: Positive | I _{DD} | | 5 | 6 | mA | |
| Supply Current: Negative | I _{SS} | | 5 | 6 | mA | |
| Current Sensor Inputs (Differential) | | | | | | |
| Input Current Range | I _{II} | -25 | | +25 | µA | Peak value |
| Voltage Sensor Input (Asymmetrical) | | | | | | |
| Input Current Range | I _{IV} | -25 | | +25 | µA | Peak value |
| Pin VREF | | | | | | |
| Ref. Current Ref. Voltage | -I _R V _R | 45 1.1 | 50 | 55 1.3 | µA V | With R = 24kΩ connected to V _{SS} Reference to V _{SS} |
| Digital I/O | | | | | | |
| Pin CNF Input High Voltage Input Low Voltage | V _{IH} V _{IL} | V _{DD} -1 | | V _{SS} +1 | V V | |
| Pin MOP, MON, LED, SCL Output High Voltage Output Low Voltage | V _{OH} V _{OL} | V _{DD} -1 | | V _{SS} +1 | V V | I _{OH} = -2mA I _{OL} = 5mA |
| Pin SEL1, ELT, SDA, DIRO Input High Voltage Input Low Voltage | V _{IH} V _{IL} | V _{DD} -1 | | V _{SS} +1 | V V | Bi-direct** |

#Extended Operating Temperature Range available on request.

ABSOLUTE MAXIMUM RATINGS*

| Parameter | Symbol | Min | Max | Unit |
|-----------------------|----------------------------------|------|------|------|
| Supply Voltage | V _{DD} -V _{SS} | -0.3 | 6.0 | V |
| Current on any pin | I _{PIN} | -150 | +150 | mA |
| Storage Temperature | T _{STG} | -40 | +125 | °C |
| Operating Temperature | T _O | -25 | +85 | °C |

*Stresses above those listed under “Absolute Maximum Ratings” may cause permanent damage to the device. This is a stress rating only. Functional operation of the device at these or any other condition above those indicated in the operational sections of this specification, is not implied. Exposure to Absolute Maximum Ratings for extended periods may affect device reliability.

**PIN DESCRIPTION**

| PIN | Designation | Description |
|------------|--------------------------|--------------------------------------------------------------------------------------------------------------------------------------------------------------------------------------------------------------------------------------------------|
| 20 | GND | Analog Ground. The voltage to this pin should be mid-way between V_{DD} and V_{SS} . |
| 8 | V_{DD} | Positive supply voltage. The voltage to this pin is typically +2.5V if a shunt resistor is used for current sensing or in the case of a current transformer a +5V supply can be applied. |
| 14 | V_{SS} | Negative supply voltage. The voltage to this pin is typically -2.5V if a shunt resistor is used for current sensing or in the case of a current transformer a 0V supply can be applied. |
| 19 | IVP | The current into the A/D converter should be set at $14\mu A_{RMS}$ at nominal mains voltage. The voltage sense input saturates at an input current of $\pm 25\mu A$ peak. |
| 1, 2, 3, 4 | IIN1, IIP1 IIN2, IIP2 | Inputs for current sensor - channel 1 and channel 2. The shunt resistor voltage from each channel is converted to a current of $16\mu A_{RMS}$ at rated conditions. The current sense input saturates at an input current of $\pm 25\mu A$ peak. |
| 5 | VREF | This pin provides the connection for the reference current setting resistor. A 24k Ω resistor connected to V_{SS} sets the optimum operating condition. |
| 6 | SCL | Serial clock output. This output is used to strobe data from the external EEPROM. |
| 7 | SDA | Serial data. Send and receive data from an external EEPROM. |
| 9, 12 | MON, MOP | Motor pulse outputs. These outputs can be used to drive an impulse counter or stepper motor directly. |
| 13 | LED | Calibration LED output. Refer to section Led Output (LED) for the pulse rate output options. |
| 15 | CNF | Configure / Test input. For normal operation this pin must be pulled to V_{SS} . |
| 16 | SEL1 | Current channel select output. This output indicates which channel is been used for kWh metering. |
| 17 | ELT | Earth loop tamper output. This output indicates an earth loop tamper condition. |
| 18 | DIRO | Direction output. This output indicates the energy flow direction. |
| 10, 11 | OSC1, OSC2 | Connections for a crystal or ceramic resonator. (OSC1 = input; OSC2 = Output) |

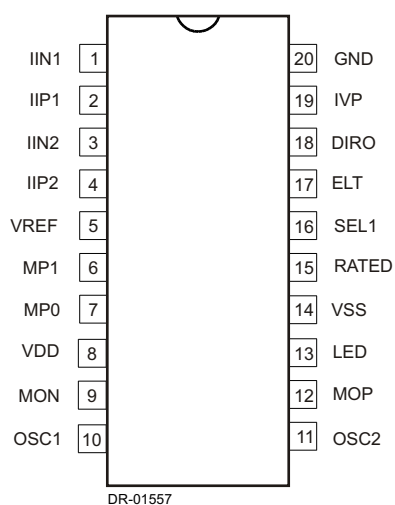
**ORDERING INFORMATION**

| Part Number | Package |
|-------------|---------|
| SA9607PPA | DIP-20 |
| SA9607PSA | SOIC-20 |

Figure 2: Pin connections: Package: DIP-20, SOIC-20

FUNCTIONAL DESCRIPTION

The SA9607P is a CMOS mixed signal analog/digital integrated circuit, which performs power/energy calculations across a power range of 1000:1, to an overall accuracy of better than Class 1.

The integrated circuit includes all the required functions for single phase power and energy measurement such as oversampling A/D converters for the voltage and current sense inputs, power calculation and energy integration. Internal offsets are eliminated through the use of cancellation procedures. The SA9607P incorporates an anti-tamper scheme by continuously measuring the power consumption on both LIVE and NEUTRAL lines. A fault is indicated when these measurements differ by more than 12.5%. The SA9607P generates pulses with a frequency proportional to the larger of the two current measurements. The source (LIVE or NEUTRAL) for these pulses is indicated on the SEL1 pin.

Various pulse outputs (MOP, MON and LED) are available. The pulse rate on these pins follows the active power consumption measured.

A low voltage stepper may be driven directly from the device by connecting it between the MOP and MON pins, alternatively an impulse counter may be driven directly by connecting it between MOP and V_{SS} .

The SA9607P configures itself from an external low cost EEPROM that contain all meter configurations and calibration data. No external trimming is required for this device. Calibration of the device may be fully automated.

POWER CALCULATION

In Figure 7, the voltage drop across the current transformers terminating resistor will be between 0 and $16mV_{RMS}$. These voltages are converted to currents for each current input by means of resistors R_1 and R_2 (channel 1) as well as R_3 and R_4 (channel 2).

The current sense input saturates at an input current of $\pm 25\mu A$ peak. The mains voltage (230VAC) is divided down through a divider to $14V_{RMS}$. The current into the A/D converter input is set at $14\mu A_{RMS}$ at nominal mains voltage, via resistor R_6 ($1M\Omega$).

See Device Configuration for more details on the processing of measured energy to frequency outputs.

ANALOG INPUT CONFIGURATION

The input circuitry of the current and voltage sensor inputs are illustrated below in figure 3. These inputs are protected against electrostatic discharge through clamping diodes.

The feedback loops from the outputs of the amplifiers A_I and A_V generate virtual shorts on the signal inputs. Exact duplications of the input currents are generated for the analog signal processing circuitry.

AUTOMATIC DEVICE CONFIGURATION (BOOT UP)

During power up, registers containing configuration and calibration information is updated from an external EEPROM. The device itself never writes to the EEPROM so any write protect features offered by manufacturer of EEPROM's may be used to protect the configuration and calibration constants of the meter. The device reloads its configuration every 1193 seconds from the external EEPROM in order to ensure correct operation of the meter. Every data byte stored in the EEPROM is protected with a checksum byte to ensure data integrity.

ELECTROSTATIC DISCHARGE (ESD) PROTECTION

The SA9607P integrated circuit's input's/outputs are protected against ESD.

POWER CONSUMPTION

The power consumption rating of the SA9607P integrated circuit is less than 30mW.

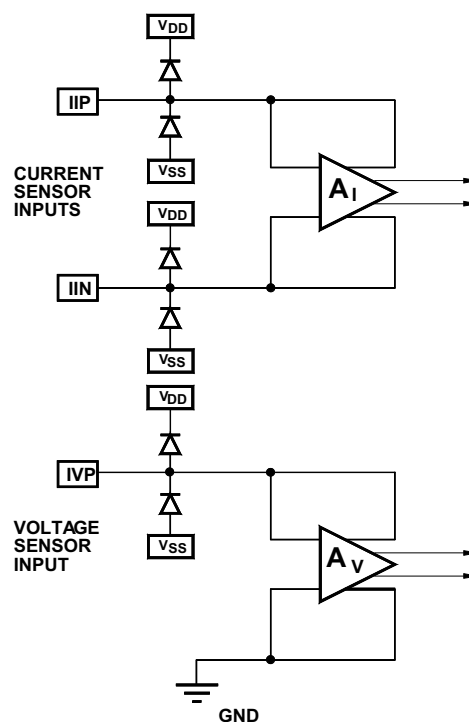

DR-01288

Figure 3: Analog Input Internal Configuration



INPUT SIGNALS

VREF

The VREF pin is the reference for the bias resistor and is the recommended point for analog calibration. With a bias resistor of 24kΩ optimum conditions are set. Any changes to the bias resistor will affect the output pulse rate quadratically (i.e. ΔR = +5%, Δf = 10%).

Serial Data (SDA)

The SDA pin connects directly to the SDA pin of an external EEPROM. The pin is used to transfer data between the EEPROM to the SA9607P. An external pull up resistor is not needed.

Serial Clock (SCL)

The SCL pin connects directly to the SCL of an external EEPROM. The SCL output is used to strobe data at a rate of 50kHz out of the EEPROM. An external pull up resistor is not needed.

Configuration (CNF)

A rising edge on the CNF pin with DIRO high, will trigger a register update from the external EEPROM. This feature may be used during calibration to load updated register data in the SA9607P. For normal operation of the SA9607P the CNF pin should be pulled to V_{ss} with a resistor. A capacitor between CNF and V_{DD} with the resistor to V_{ss} will enable the device to be reloaded on startup power supply transients.

OUTPUT SIGNALS

Motor output (MOP, MON)

The motor pulse width is programmable for 71ms and 142ms. The MON pulse will follow the MOP pulse within the selected pulse width time. This prevents that the motor armature is in the wrong position after a power failure. Both MOP and MON outputs are active high. One energy pulse is represented by a MOP pulse followed by a MON pulse. The motor drive wave forms are shown in figure 4.

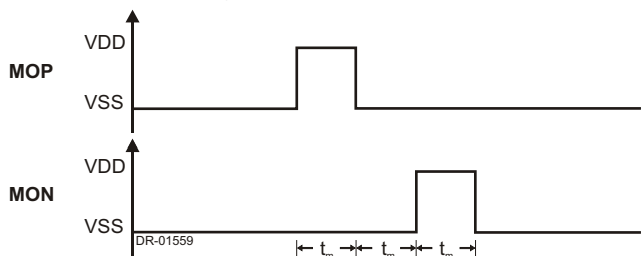

t_m = 71ms, 142ms

Figure 4: Motor drive on MON and MOP pins of device

LED output (LED)

Three options for the LED output pulse rate area available, 6400 and 3200 pulses per kWh, as well as a pulse rate of 1252

pulses per second at rated conditions. At 1252 pulses per second t_{LED} is 71μs, for the other options t_{LED} is 10ms. The LED output is active low as in figure 5.

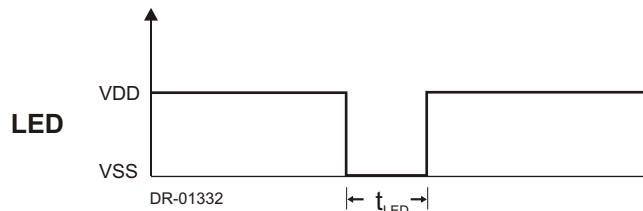

t_{LED} = 10ms (6400 or 3200 pulses per kWh)
t_{LED} = 71μs (1252 pulses per second)

Figure 5: LED pulse output

Selected input indication (SEL1)

The SA9607P continuously compares the power consumptions on both channel 1 and channel 2 inputs. The larger of the two measurements are used for pulse output generations. The SEL1 output pin indicates which channel is currently being used for the pulse output.

| Signal Output | Value | Description |
|---------------|-------|----------------------------------------|
| SEL 1 | 0 | Current Channel 1 selected (IIN1/IIP1) |
| | 1 | Current Channel 2 selected (IIN2/IIP2) |

Earth loop tamper indication (ELT)

If the power measurements from both current channels differ by more than 12.5%, (indicating a earth loop tamper condition), the ELT output is set to zero. The SA9607P continues to generate output pulses from the larger of the two measured powers in this condition. The ELT output is active low.

Direction indication (DIRO)

The SA9607P provides information about the energy flow direction of both current channels on pin DIRO .

A logic 1 on pin DIRO indicates reverse energy flow of both current channels. Reverse energy flow is defined as the condition where the voltage sense input and current sense input are out of phase (greater than 90 degrees).

Positive energy flow, when voltage sense and both current sense input are in phase, is indicated on pin DIRO as a logic 0.

The DIRO pin may be used to drive a LED in order to indicate reverse energy.

| Signal Output | Value | Description |
|---------------|-------|---------------------|
| DIRO | 1 | Reverse energy flow |
| | 0 | Forward energy flow |

A capacitor between DIRO and VSS will cause the DIRO signal to stay high during power up transients.



DEVICE CONFIGURATION SIGNAL FLOW DESCRIPTION

The following is an overview of the SA9607P's registers. For a detailed description of each parameter please refer to parameter description section.

Figure 6 shows the various registers in the SA9607P's power to pulse rate block. The inputs to this block are two single bit pulse density modulated signals, each having a pulse rate of 641454 pulses per second at rated conditions. The parameters Kc1, Kc2, Ne, Cs, Kr, Cres, and Cled contains values which are read from the external EEPROM during power up.

The divider registers, *Channel 1 Balance* and *Channel 2 Balance*, are used for calibration and to balance the gain of

each channel. The *Earth Leakage Compensation* register is used to compensate for any permissible earth leakage that may cause the SA9607P to indicate a tamper condition at low current. The *Channel Select* register selects the source (channel 1 or channel 2) which will be used for the pulse output. Register *Rated Condition* is used to program the rated condition of the meter and feeds the registers *LED-constant* and *Counter Resolution* with the applicable pulse rate. These two registers are programmed to select the LED output rate and the counter resolution (pulses per kWh) respectively. The *Counter Pulse Width* register is used to program the pulse width for the mechanical counter driver output MOP and MON.

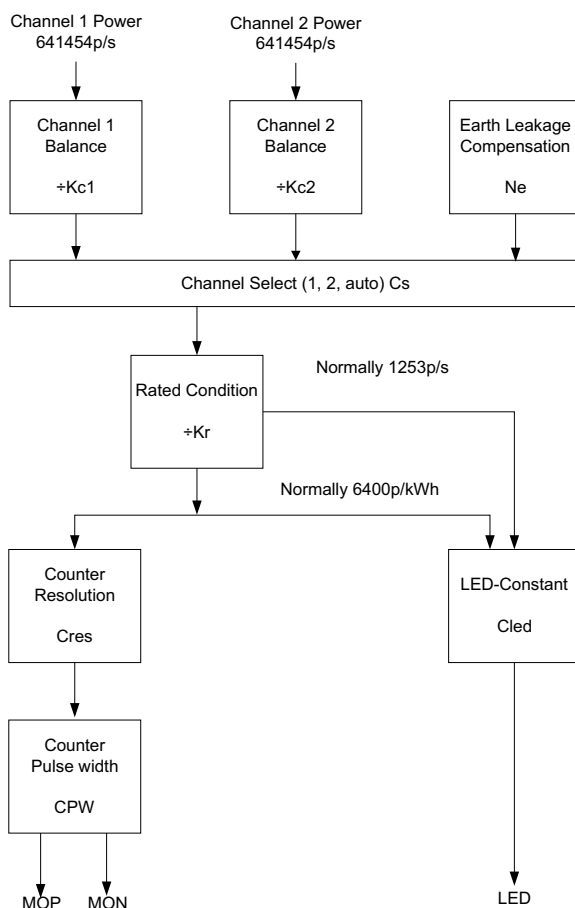

Figure 6: Signal flow block diagram



SA9607P

PARAMETER DESCRIPTION

Refer to the EEPROM memory allocation map as well as the Signal flow diagram figure 6, for a description of the registers used in this section.

EEPROM Memory Allocation

The following table shows the EEPROM memory allocation as well as the corresponding name. The uneven byte always contains a XORed byte of the previous even byte. This is the checksum byte used by the SA9607P to ensure data integrity.

Channel Balance (Kc)

Kc defines the dividing factor, which is applied to the incoming pulse rate. This value is typically 5111. This factor is used for calibration meter and gain balancing of the 2 current channels. The value for Kc is usually between 4000 and 640.

Kc is made up of 2 bytes, D12 and D14 or D16 or D18 which forms at 10 bit value.

Rated Condition (Kr)

Kr is used to program the rated condition of the meter. This feature is required for a correct counter increment of meters designed for different rated conditions using the same integrated circuit. Rated conditions from less than several 100A are possible.

The channel balance values should be used to compensate for rounding errors in Kr. Kr is calculated as follows:

$$Kr = (1252 \times 1000 \times 3600) / (\text{Rated volt} \times \text{Rated current} \times 6400) - 1$$

Kr is made up of 1 byte (D20)

| Description | E ² Address | Contents | Bit [7:0] | Name |
|-------------------------|------------------------|----------------|-----------|------|
| Channel 1 Balance LSB | 12 | Kc1 | vvvvvvvv | D12 |
| | 13 | XOR of ADDR 12 | xxxxxxxx | |
| Channel 1 Balance MSB | 14 | Kc1 | -----vv | D14 |
| | 15 | XOR of ADDR 14 | xxxxxxxx | |
| Channel 2 Balance LSB | 16 | Kc2 | vvvvvvvv | D16 |
| | 17 | XOR of ADDR 16 | xxxxxxxx | |
| Channel 2 Balance MSB | 18 | Kc2 | -----vv | D18 |
| | 19 | XOR of ADDR 18 | xxxxxxxx | |
| Rated Condition | 20 | Kr | vvvvvvvv | D20 |
| | 21 | XOR of ADDR 22 | xxxxxxxx | |
| Led Pulse-rate | 22 | Cled | -----vv | D22 |
| | 23 | XOR of ADDR 22 | xxxxxxxx | |
| Counter Pulse-width | 24 | Cpw | 0v----- | D24 |
| Counter Resolution | 24 | Cres | -----vv | |
| | 25 | XOR of ADDR 24 | 1xxxxxxxx | |
| Earth leak Compensation | 26 | Ne | -----vv | D26 |
| Channel Select Mode | 26 | Cs | ----v-- | |
| | 27 | XOR of ADDR 24 | xxxxxxxx | |

KEY: (- = DON'T CARE); (V = VALUE/PARAMETER); (0,1 = LOGICAL VALUE); (X = BIT-XOR)

**LED Pulse-rate (CLED)**

Two bits of byte D22 allow for the selection of 3 different LED Pulse-rate as follows.

| D22[1] | D22[0] | Calibrated LED - Output |
|--------|--------|------------------------------------------------|
| 0 | 0 | 6400 p/KWh |
| 0 | 1 | 3200 p/KWh |
| 1 | - | 1252 pulses/second @rated for fast calibration |

Refer to LED output section for details on the LED pulse width.

Counter Pulse-Width (CPW)

The pulse width for the mechanical counter driver output is selectable to accommodate various step-motor and impulse-counter requirements. Bit 6 from byte D24 selects the pulse rate as follows:

| D24[6] | Counter Pulse-Width |
|--------|---------------------|
| 0 | 71ms |
| 1 | 142ms |

Counter Resolution (CRES)

Bit 1 and 0 from byte D24 allow for the selection of 3 different counter resolutions. Note that one energy pulse is represented by a MOP pulse followed by a MON pulse.

| D24[1] | D24[0] | Counter Resolution |
|--------|--------|--------------------|
| 0 | 0 | 1 p/KWh |
| 1 | 0 | 10 p/KWh |
| - | 1 | 100 p/KWh |

Channel Select Mode (CS)

For calibration purposes, the source for the energy metering may be selected from a specific channel. The ELT-indication is not influenced, but the metering is taken from the selected channel only. For normal operation, the channel select mode is set to automatic mode so that the larger of the two channels is used for energy measurement. Bits 3 and 2 of byte D26 sets the channel select mode as follows:

| D26[3] | D26[2] | Metering Source |
|--------|--------|--------------------------------------------------------------|
| - | 0 | Automatic, channel 1 or 2 whichever shows higher consumption |
| 1 | 1 | Channel 1 |
| 0 | 1 | Channel 2 |

Earth Leak Compensation (NE)

Earth leakage in domestic wiring systems could result in tamper detection at low current levels. The SA9607P caters for these conditions, by taking possible earth leakage into account when comparing the power consumption on live and neutral.

The value for the permissible earth leakage is usually around 30mA. It has to be adjusted according to the rated meter condition and allows for derivations from the 30mA value. The actual value of the leak current can be calculated from the following formula:

$$I_{leak} = \text{Rated current} \times N_e$$

I_{leak} is the earth leakage current in mA used for correction. this value is subtracted from the difference measured between live and neutral power.

N_e is made up of bits 1 and 2 of byte D26 and can be set as follows:

| D26[1] | D26[0] | N_e factor |
|--------|--------|--------------|
| 0 | 0 | 0.15 |
| 0 | 1 | 0.076 |
| 1 | - | 0.032 |



TYPICAL APPLICATION

In Figure 7, the components required for a stand-alone power metering application, is shown. Application modules as well as application notes for the SA9607P and SA9607M Integrated Circuits are available on request.

Two current transformers are used for mains current sensing. The current channel showing the highest power consumption will be selected by the SA9607P for energy metering.

The most important external components for the SA9607P integrated circuit are the current sense resistors, the voltage sense resistors as well as the bias setting resistor.

CURRENT SENSE RESISTORS

The resistors R1, R2, R3 and R4 define the current level into the current sense inputs of the device. The component should be selected for input currents of $16\mu A_{RMS}$ into the current channels of the SA9607P at I_{MAX} (rated current of the meter). The voltage drop on the shunt termination resistors R_{10} and R_{17} should be at least 20mV.

| |
|----------------------------------------------------------------------------|
| Current Channel 1 $R_1 = R_2 = (I_L / 16\mu A_{RMS}) \times R_{10} / 2$ |
| Current Channel 2 $R_3 = R_4 = (I_L / 16\mu A_{RMS}) \times R_{11} / 2$ |

Where:

- IL = Line current /CT-ratio
- R10 = Termination resistor
- R11 = Termination resistor

Voltage Sense Resistors

R9, R8, R6 and R5 set the current for the voltage sense input. The values should be selected so that the input current into the voltage sense input (virtual ground) is set to $14\mu A_{RMS}$. A capacitor is used to compensate for a phase shift introduced by the CTs.

Bias Resistor

R_7 defines all on-chip bias and reference currents. With $R_7 = 24k\Omega$, optimum conditions are set.

Any change to R_7 will affect the output quadratically.

Compatible EEPROM Devices

The following devices were tested and found functional with the SA9607P.

| Devices | Manufacturer | WEB Site |
|----------|---------------------|---------------------------------------------------------|
| AT24C01A | Atmel | http://www.atmel.com |
| 24C01 | STMicro electronics | http://www.st.com |

Please see various manufacturers datasheets on programming and using IIC memory devices.

Software for programming the EEPROM devices is available from SAMES website.

**SA9607P****Parts List for Application Circuit: Figure 7**

| Item | Symbol | Description | Detail |
|------|--------|--------------------------------------|----------------|
| 1 | IC1 | SA9607P | DIP-20/SOIC-20 |
| 2 | IC2 | AT24C01, or equivalent device | |
| 3 | D1 | Diode, Silicon 1N4007 | |
| 4 | D2 | Diode, Silicon 1N4007 | |
| 5 | D3 | Diode, Silicon 1N4007 | |
| 6 | D4 | Diode, Silicon 1N4007 | |
| 7 | D5 | Light emitting diode, Red | |
| 8 | D6 | Light emitting diode, Green | |
| 9 | D7 | Light emitting diode, Amber | |
| 10 | D8 | Light emitting diode, Green | |
| 11 | XTAL | Crystal, 3.5759MHz | |
| 12 | R1 | Resistor, 1/4W, 1%, metal | Note 1 |
| 13 | R2 | Resistor, 1/4W, 1%, metal | Note 1 |
| 14 | R3 | Resistor, 1/4W, 1%, metal | Note 1 |
| 15 | R4 | Resistor, 1/4W, 1%, metal | Note 1 |
| 16 | R5 | Resistor, 1M, 1/4W, 1%, metal | |
| 17 | R6 | Resistor, 24k, 1/4W, 1%, metal | |
| 18 | R7 | Resistor, 22k, 1/4W, 1%, metal | |
| 19 | R8 | Resistor, 180k, 1/4W, 1%, metal | |
| 20 | R9 | Resistor, 200k, 1/4W, 1%, metal | |
| 21 | R10 | Resistor, 1/4W, 1%, metal | Note 2 |
| 22 | R11 | Resistor, 1/4W, 1%, metal | Note 2 |
| 23 | R12 | Resistor, 10Ω, 2W, Wire wound | |
| 24 | R13 | Resistor, 1k, 1/4W, 1%, metal | |
| 25 | R14 | Resistor, 1k, 1/4W, 1%, metal | |
| 26 | R15 | Resistor, 1k, 1/4W, 5%, carbon | |
| 27 | R16 | Resistor, 1k, 1/4W, 5%, carbon | |
| 28 | R17 | Resistor, 1k, 1/4W, 5%, carbon | |
| 29 | R18 | Resistor, 1k, 1/4W, 5%, carbon | |
| 30 | R19 | Resistor, 22k, 1/4W, 1%, metal | Note 5 |
| 31 | C1 | Capacitor, 2200μF, 16V, electrolytic | |
| 32 | C2 | Capacitor, 100μF, 16V, electrolytic | |
| 33 | C3 | Capacitor | Note 4 |
| 34 | C4 | Capacitor, 220nF | |
| 35 | C5 | Capacitor, 220nF | |
| 35 | C6 | Capacitor, 820nF | Note 3 |
| 35 | C7 | Capacitor, 100nF | Note 5 |
| 35 | C8 | Capacitor, 100nF | Note 5 |
| 35 | C9 | Capacitor, 100nF | |
| 36 | CT1 | Current Transformer | |
| 37 | CT2 | Current Transformer | |
| 38 | TX | Transformer, 230V/9V | |
| 39 | IC3 | 78LC05, Voltage regulator | |
| 40 | M1 | Bipolar step motor | |
| 41 | MOV | 400V, Metal oxide varistor | |

Note 1: Resistor (R1, R2, R3 and R4) values are dependent upon the selected value of R10 and R11

Note 2: See TYPICAL APPLICATION when selected the value of R10 and R11.

Note 3: Capacitor (C6) to be positioned as closed to Supply Pins (V_{DD} & V_{SS}) of IC-1, as possible.

Note 4: Capacitor (C3) selected to minimize phase error introduced by current transformer (typically 1.5μF for normal Cts)

Note 5: Components enable reloading during mains power up with transients



sames

SA9607P

DISCLAIMER:

The information contained in this document is confidential and proprietary to South African Micro-Electronic Systems (Pty) Ltd ("SAMES") and may not be copied or disclosed to a third party, in whole or in part, without the express written consent of SAMES. The information contained herein is current as of the date of publication; however, delivery of this document shall not under any circumstances create any implication that the information contained herein is correct as of any time subsequent to such date. SAMES does not undertake to inform any recipient of this document of any changes in the information contained herein, and SAMES expressly reserves the right to make changes in such information, without notification, even if such changes would render information contained herein inaccurate or incomplete. SAMES makes no representation or warranty that any circuit designed by reference to the information contained herein, will function without errors and as intended by the designer.

Any sales or technical questions may be posted to our e-mail address below:
energy@sames.co.za

For the latest updates on datasheets, please visit our web site:
<http://www.sames.co.za>.

SOUTH AFRICAN MICRO-ELECTRONIC SYSTEMS (PTY) LTD

Tel: (012) 333-6021
Tel: Int +27 12 333-6021
Fax: (012) 333-8071
Fax: Int +27 12 333-8071

**P O BOX 15888
33 ELAND STREET
LYNN EAST 0039
REPUBLIC OF SOUTH AFRICA**

**33 ELAND STREET
KOEDOESPOORT INDUSTRIAL AREA
PRETORIA
REPUBLIC OF SOUTH AFRICA**