



SA9102F/SA9102H

SINGLE PHASE BIDIRECTIONAL POWER/ENERGY METERING IC WITH INSTANTANEOUS PULSE OUTPUT

FEATURES

- Performs bidirectional power and energy measurement
- Meets the IEC 521/1036 Specification requirements for Class 1 AC Watt hour meters
- Protected against ESD
- Power consumption rating typically 25mW
- Adaptable to different types of current sensors
- Operates over a wide temperature range
- Precision voltage reference on-chip
- Two output signal formats available

DESCRIPTION

The SAMES SA9102F and SA9102H Single Phase bidirectional Power/Energy metering integrated circuits generate pulse rate outputs for positive and negative energy directions, the frequency of which is proportional to the power consumption. These devices perform the calculation for active power.

The method of calculation takes the power factor into account.

Energy consumption is determined by the power measurement being integrated over time.

These innovative universal power/energy metering integrated circuits are ideally suited for energy calculations in applications such as electricity dispensing systems (ED's), residential municipal metering and factory energy metering and control.

The SA9102F and SA9102H integrated circuits are available in both 20 pin dual-in-line plastic (DIP-20), as well as 20 pin small outline (SOIC-20) package types.

PIN CONNECTIONS

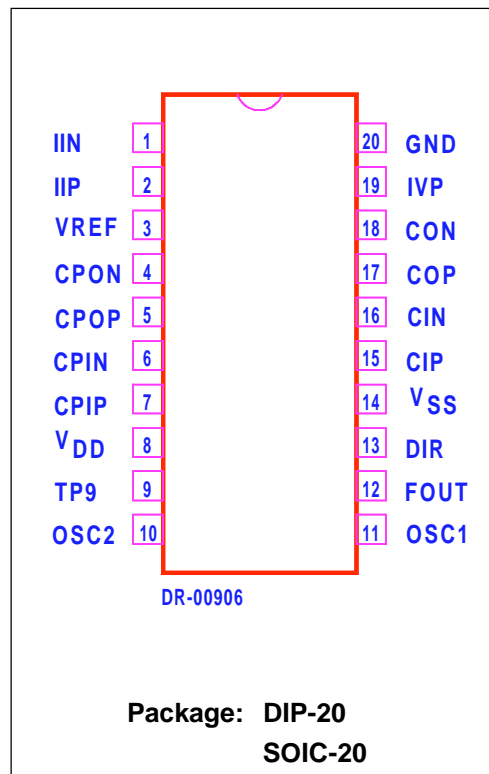

BLOCK DIAGRAM

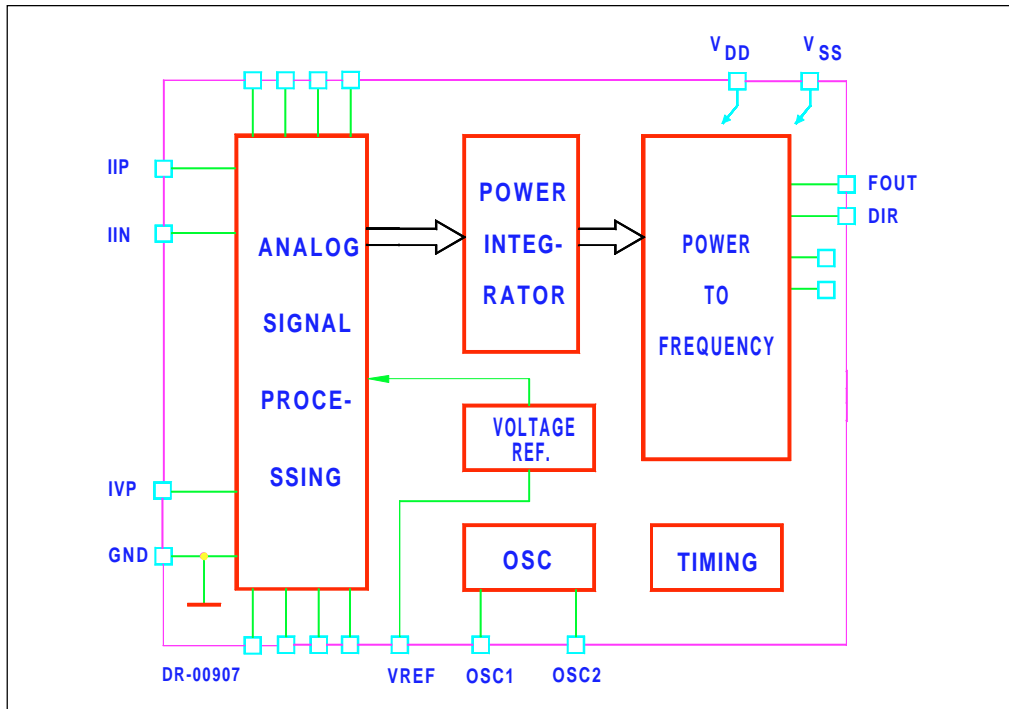

ABSOLUTE MAXIMUM RATINGS*

Parameter	Symbol	Min	Max	Unit
Supply Voltage	$V_{DD} - V_{SS}$	-0.3	6.0	V
Current on any pin	I_{PIN}	-150	+150	mA
Storage Temperature	T_{STG}	-40	+125	°C
Operating Temperature	T_O	-40	+85	°C

* Stresses above those listed under "Absolute Maximum Ratings" may cause permanent damage to the device. This is a stress rating only. Functional operation of the device at these or any other condition above those indicated in the operational sections of this specification, is not implied. Exposure to Absolute Maximum Ratings for extended periods may affect device reliability.

ELECTRICAL CHARACTERISTICS

($V_{DD} = 2.5V$, $V_{SS} = -2.5V$, over the temperature range $-10^{\circ}C$ to $+70^{\circ}C^{\#}$, unless otherwise specified.)

Parameter	Symbol	Min	Typ	Max	Unit	Condition
Supply Voltage: Positive	V_{DD}	2.25		2.75	V	
Supply Voltage: Negative	V_{SS}	-2.75		-2.25	V	
Supply Current: Positive	I_{DD}		5	6	mA	
Supply Current: Negative	I_{SS}		5	6	mA	
Current Sensor Inputs (Differential)						
Input Current Range	I_{II}	-25		+25	μA	Peak value
Voltage Sensor Input (Asymmetrical)						
Input Current Range	I_{IV}	-25		+25	μA	Peak value
Pins FOUT, DIR Output Low Voltage Output High Voltage	V_{OL} V_{OH}	$V_{DD}-1$		$V_{SS}+1$	V V	$I_{OL} = 5mA$ $I_{OH} = -2mA$
Pulse Rate FOUT	f_p	0 0		64 180	Hz Hz	Specified linearity Min and max limits
Oscillator	Recommended crystal: TV colour burst crystal $f = 3.5795$ MHz					
Pin VREF Ref. Current Ref. Voltage	$-I_R$ V_R	45 1.1	50	55 1.3	μA V	With $R = 24k\Omega$ connected to V_{SS} Referred to V_{SS}

[#] Extended Operating Temperature Range available on request.

SA9102F/SA9102H

PIN DESCRIPTION

Pin	Designation	Description
20	GND	Ground
8	V _{DD}	Positive Supply Voltage
14	V _{SS}	Negative Supply Voltage
19	IVP	Analog input for Voltage
1	IIN	Inputs for current sensor
2	IIP	
11	OSC1	Connections for crystal or ceramic resonator (OSC1 = Input ; OSC2 = Output)
10	OSC2	
12	FOUT	Pulse rate output
13	DIR	Direction indication output
4	CPON	Connections for outer loop capacitor of A/D converter (Voltage)
5	CPOP	
6	CPIN	Connections for inner loop capacitor of A/D converter (Voltage)
7	CPIP	
15	CIP	Connections for inner loop capacitor of A/D converter (Current)
16	CIN	
17	COP	Connections for outer loop capacitor of A/D converter (Current)
18	CON	
3	VREF	Connection for current setting resistor
9	TP9	Test Pin. Connect to V _{SS}

FUNCTIONAL DESCRIPTION

The SA9102F/SA9102H are CMOS mixed signal Analog/Digital integrated circuits, which perform bidirectional power/energy calculations across a power range of 1000:1, to an overall accuracy of better than Class 1.

These integrated circuits includes all the required functions such as two oversampling A/D converters for the voltage and current sense inputs, power calculation and energy integration. Internal offsets are eliminated through the use of cancellation procedures. These devices generate pulses, the frequency of which is proportional to the power consumption. The pulse rate follows the instantaneous power measured. Direction information is also provided.

1. Power calculation

In the Application Circuit (Figure 1), the voltage drop across the shunt will be between 0 and 16mV (0 to 80A through a shunt resistor of $200\mu\Omega$). This voltage is converted to a current of between 0 and 16 μ A, by means of resistors R_1 and R_2 .

The current sense input saturates at an input current of $\pm 25\mu$ A peak.

For the voltage sensor input, the mains voltage (230VAC) is divided down through a divider to 14V. The current into the A/D converter input is set at 14 μ A at nominal mains voltage, via resistor R4 (1M Ω).

In this configuration, with a mains voltage of 230V and a current of 80A, the output frequency of the SA9102F and SA9102H power meter chips at FOOUT (Pin 12) is 64Hz. In this case 1 pulse will correspond to an energy consumption of 18.4kW/64Hz = 287.5Ws.

2. Analog Input configuration

The input circuitry of the current and voltage sensor inputs are illustrated below.

These inputs are protected against electrostatic discharge through clamping diodes.

The feedback loops from the outputs of the amplifiers A_I and A_V generate virtual shorts on the signal inputs. Exact duplications of the input currents are generated for the analog signal processing circuitry.

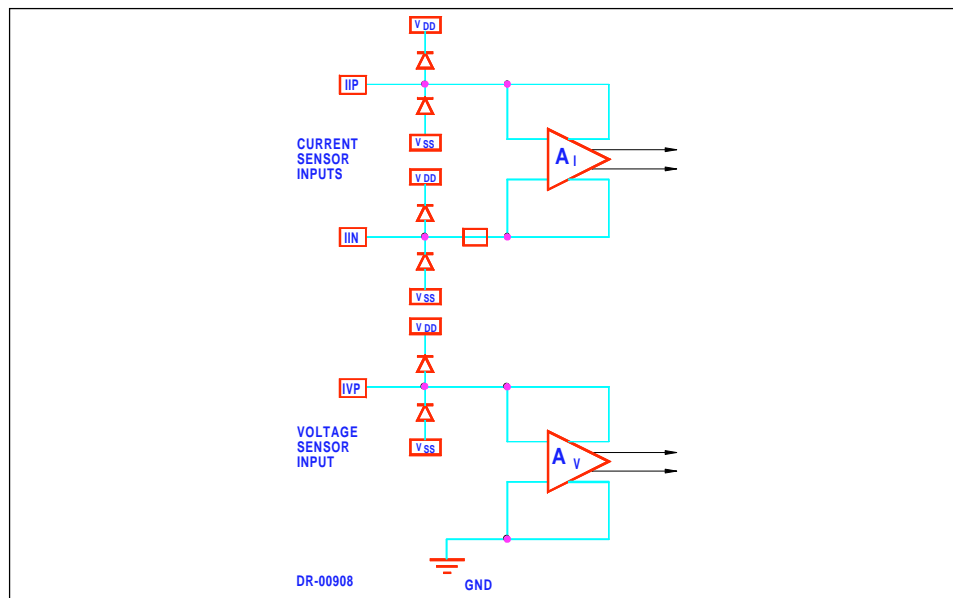

SA9102F/SA9102H

3. Electrostatic Discharge (ESD) Protection

The SA9102F/SA9102H integrated circuits inputs/outputs are protected against ESD.

4. Power Consumption

The power consumption rating of the SA9102F and SA9102H integrated circuits is less than 30mW.

5. Pulse Output Signals

The calculated power is divided down to a pulse rate of 64Hz, for rated conditions on FOUT (Pin 12), for both the SA9102F and SA9102H.

The format of the pulse output signal, which provides power/energy and direction information, is the only difference between the SA9102F and SA9102H devices.

The direction of the energy flow is defined by the mark/space ratio in the SA9102F, while the pulse width defines the direction on the SA9102H.

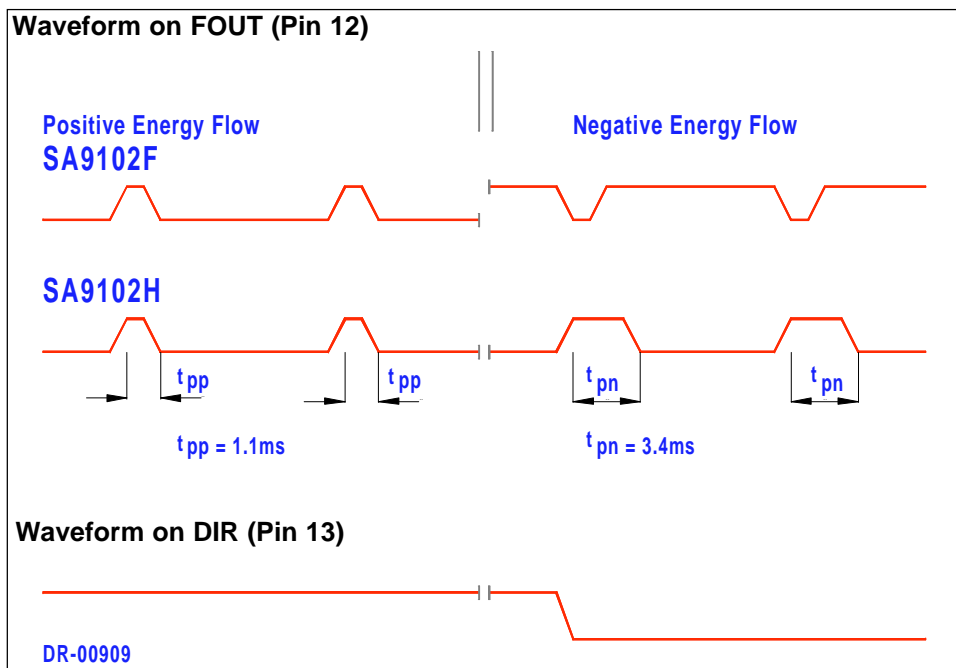

An integrated anticreep function ensures no metering at zero line currents.

The formula for calculating the output frequency (f) is given below:

$$f = 11.16 * F_{OUTX} * \frac{F_{OSC}}{3.58\text{MHz}} * \frac{I_I \cdot I_V}{I_R^2}$$

Where F_{OUTX} = Nominal rated frequency (64Hz)

F_{OSC} = Oscillator frequency (2MHz 4MHz)

I_I = Input currents for current inputs (16 μ A at rated)

I_V = Input currents for voltage inputs (14 μ A at rated)

I_R = Reference current (typically 50 μ A)

XTAL is a colour burst TV crystal (f = 3.5795MHz) for the oscillator. The oscillator frequency is divided down to 1.7897MHz on-chip, to supply the digital circuitry and the A/d converters.

TYPICAL APPLICATIONS

In the Application Circuits (Figures 1 and 2), the components required for power metering applications are shown.

In Figure 1 a shunt resistor is used for current sensing. In this application, the circuitry requires a +2.5V, 0V, -2.5V DC supply.

In the case of Figure 2, when using a current transformer for current sensing, a +5V, 0V DC supply is sufficient.

The most important external components for the SA9102F and SA9102H integrated circuits are:

C_1 and C_2 are the outer loop capacitors for the two integrated oversampling A/D converters. The value of these capacitors is 560pF.

The actual values determine signal to noise and stability performance. The tolerances should be within $\pm 10\%$.

C_3 and C_4 are the inner loop capacitors of the A/D converters. The optimum value is 3.3nF. The actual values are uncritical. Values smaller than 0.5nF and larger than 5nF should be avoided.

R_2 , R_1 and RSH are the resistors defining the current level into the current sense input. The values should be selected for an input current of 16 μ A into the SA9102F/SA9102H at maximum line current.

Values for RSH of less than 200 $\mu\Omega$ should be avoided.

$$R_1 = R_2 = (I_L / 16\mu\text{A}) * R_{SH} / 2$$

Where I_L = Line current

RSH = Shunt resistor/termination resistor

SA9102F/SA9102H

R_3 , R_6 and R_4 set the current for the voltage sense input. The values should be selected so that the input current into the voltage sense input (virtual ground) is set to $14\mu\text{A}$.

R_7 defines all on-chip bias and reference currents. With $R_7 = 24\text{k}\Omega$, optimum conditions are set. R_7 may be varied within $\pm 10\%$ for calibration purposes. Any change to R_7 will affect the output quadratically (i.e.: $R_7 = +5\%$, $f_p = +10\%$).

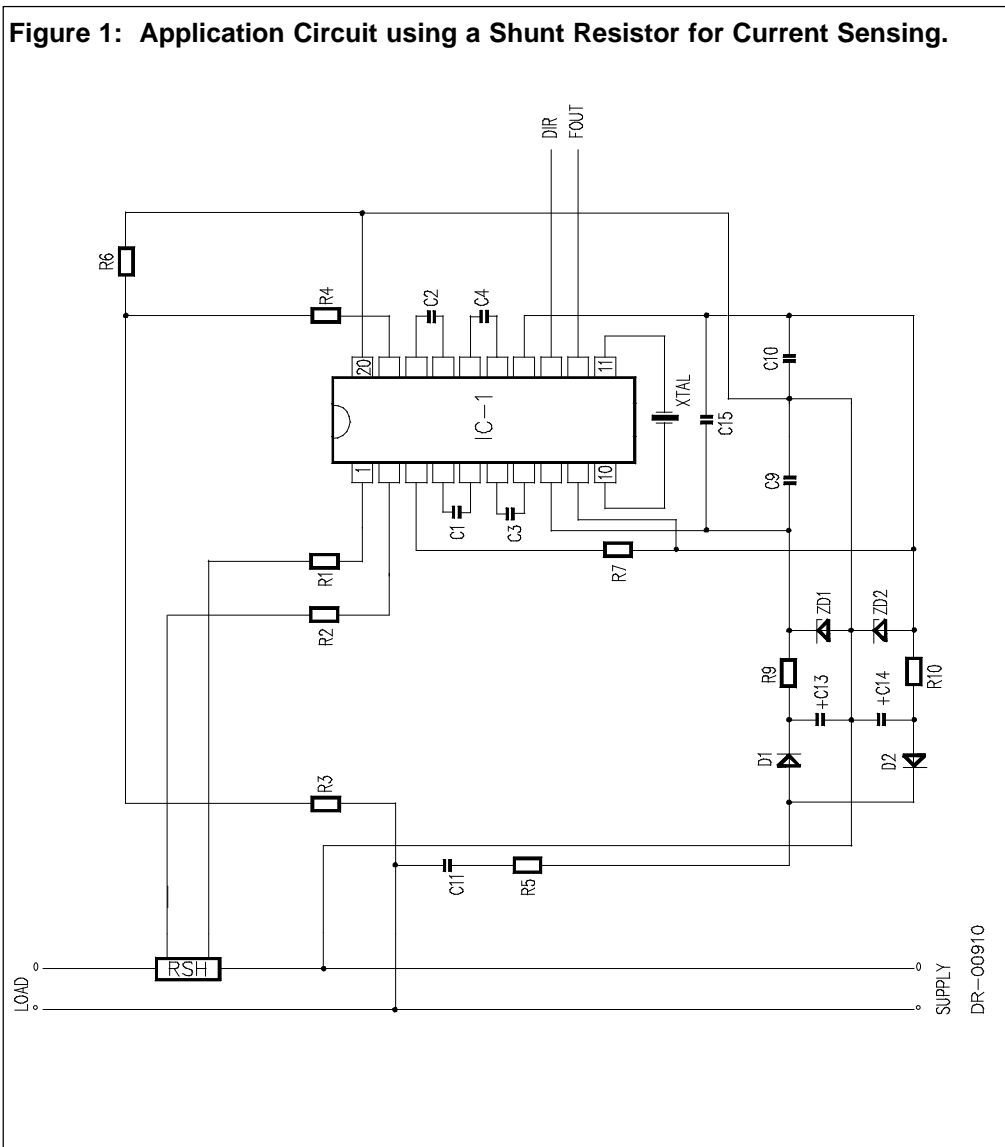

Parts List for Application Circuit: Figure 1

Item	Symbol	Description	Detail
1	IC-1	SA9102F/SA9102H	DIP-20/SOIC-20
2	D1	Diode, Silicon, 1N4148	
3	D2	Diode, Silicon, 1N4148	
4	ZD1	Diode, Zener, 2.4V, 200mW	
5	ZD2	Diode, Zener, 2.4V, 200mW	
6	XTAL	Crystal, 3.5795MHz	Colour burst TV
7	R1	Resistor, 1% metal	Note 1
8	R2	Resistor, 1% metal	Note 1
9	R3	Resistor, 390k, (230VAC) 1%, metal	
10	R4	Resistor, 1M, 1/4W, 1%, metal	
11	R5	Resistor, 470Ω, 2W, 1%, carbon	
12	R6	Resistor, 24k, 1/4W, 1%, metal	
13	R7	Resistor, 24k, 1/4W, 1%, metal	
14	R9	Resistor, 680Ω, 1/4W, 1%	
15	R10	Resistor, 680Ω, 1/4W, 1%	
16	C1	Capacitor, 560pF	
17	C2	Capacitor, 560pF	
18	C3	Capacitor, 3.3nF	
19	C4	Capacitor, 3.3nF	
20	C9	Capacitor, 100nF	
21	C10	Capacitor, 100nF	
22	C11	Capacitor, 0.47μF, 250VAC, polyester	
23	C13	Capacitor, 100μF	
24	C14	Capacitor, 100μF	
25	C15	Capacitor, 820nF	Note 2
26	RSH	Shunt Resistor	Note 3

Note 1: Resistor (R1 and R2) values are dependant upon the selected value of RSH.

Note 2: Capacitor (C15) to be positioned as close to Supply Pins (V_{DD} & V_{SS}) of IC-1 as possible.

Note 3: See TYPICAL APPLICATIONS when selecting the value of RSH.

Figure 2: Application Circuit using a Current Transformer for Current Sensing.

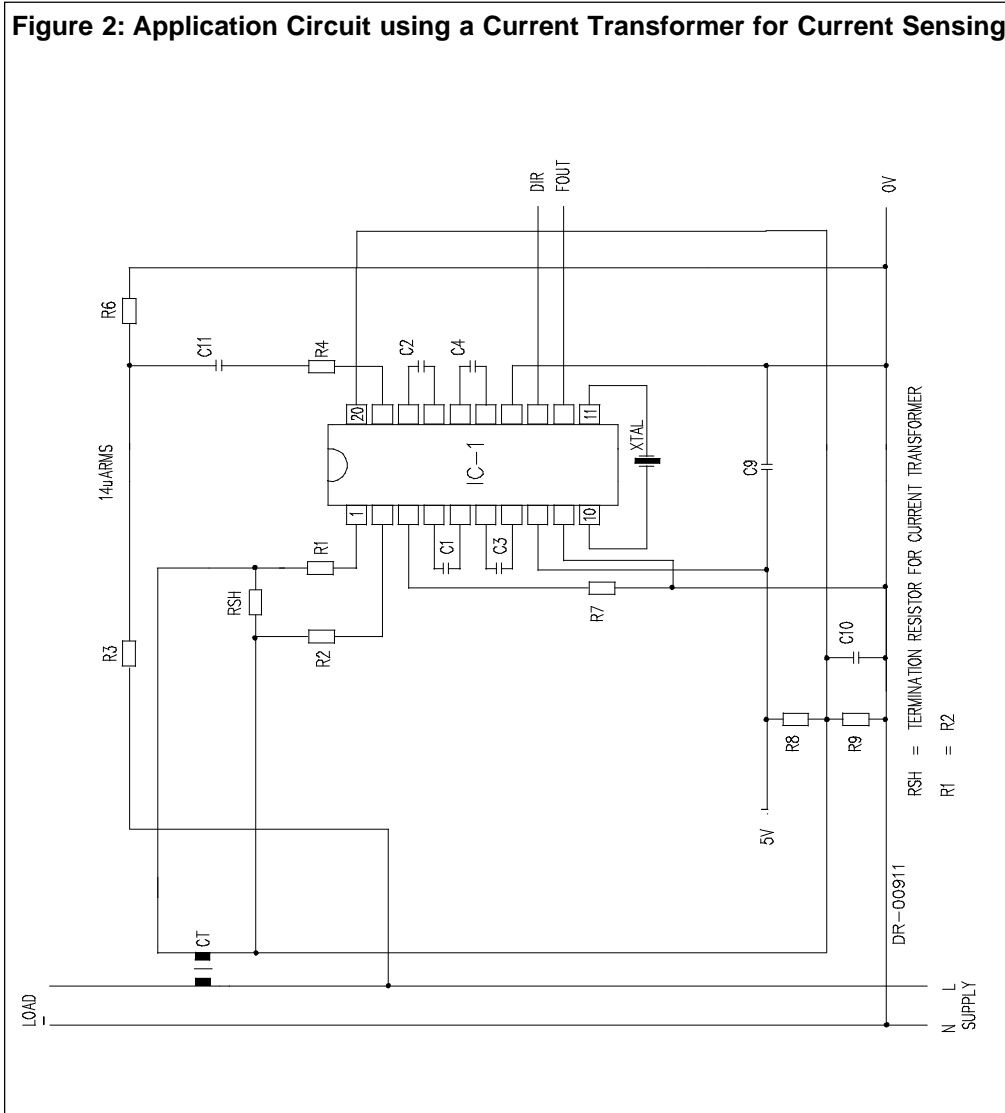

Parts List for Application Circuit: Figure 2

Item	Symbol	Description	Detail
1	IC-1	SA9102F/SA9102H	DIP-20/SOIC-20
2	XTAL	Crystal, 3.5795MHz	Colour burst TV
3	RSH	Resistor	Note 1
4	R1	Resistor, 1%, metal	Note 2
5	R2	Resistor, 1%, metal	Note 2
6	R3	Resistor, 390k, (230VAC), 1%, metal	
7	R4	Resistor, 1M, 1/4W, 1%, metal	
8	R6	Resistor, 24k, 1/4W, metal	
9	R7	Resistor, 24k, 1/4W, 1%, metal	
10	R8	Resistor, 2.2k, 1/4W, 1%, metal	
11	R9	Resistor, 2.2k, 1/4W, 1%, metal	
12	C1	Capacitor, 560pF	
13	C2	Capacitor, 560pF	
14	C3	Capacitor, 3.3nF	
15	C4	Capacitor, 3.3nF	
16	C9	Capacitor, 820nF	Note 3
17	C10	Capacitor, 100nF	
18	C11	Capacitor	Note 4
19	CT	Current Transformer	

Note 1: See TYPICAL APPLICATIONS when selecting the value of RSH.

Note 2: Resistor (R1 and R2) values are dependant upon the selected value of RSH.

Note 3: Capacitor (C9) to be positioned as close to Supply Pins (V_{DD} & V_{SS}) of IC-1, as possible.

Note 4: Capacitor (C11) selected for DC blocking and to minimize phase error introduced by current transformer (typically 1.5 μ F).

SA9102F/SA9102H

ORDERING INFORMATION

Part Number	Package
SA9102FPA	DIP-20
SA9102FSA	SOIC-20
SA9102HPA	DIP-20
SA9102HSA	SOIC-20

NOTES:



SA9102F/SA9102H

Disclaimer: The information contained in this document is confidential and proprietary to South African Micro-Electronic Systems (Pty) Ltd ("SAMES") and may not be copied or disclosed to a third party, in whole or in part, without the express written consent of SAMES. The information contained herein is current as of the date of publication; however, delivery of this document shall not under any circumstances create any implication that the information contained herein is correct as of any time subsequent to such date. SAMES does not undertake to inform any recipient of this document of any changes in the information contained herein, and SAMES expressly reserves the right to make changes in such information, without notification, even if such changes would render information contained herein inaccurate or incomplete. SAMES makes no representation or warranty that any circuit designed by reference to the information contained herein, will function without errors and as intended by the designer.

Any Sales or technical questions may be posted to our e-mail address below:
energy@sames.co.za

For the latest updates on datasheets, please visit our web site:
<http://www.sames.co.za>

South African Micro-Electronic Systems (Pty) Ltd

P O Box 15888,
Lynn East, 0039
Republic of South Africa,

33 Eland Street,
Koedoespoort Industrial Area,
Pretoria,
Republic of South Africa

Tel: 012 333-6021
Fax: 012 333-8071

Tel: Int +27 12 333-6021
Fax: Int +27 12 333-8071