

Single Channel Single Phase Energy Metering IC

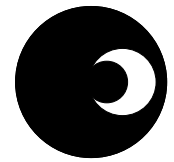

SA4106A ICDC - a division of SAMES

FEATURES

- Meets the IEC62053, CBIP-88 and IS137799-1999 specification requirements for Class 1 AC static watt-hour meters for active energy
- Motor drive outputs (MOP, MON) provide average active power information and can drive an electro-mechanical counter or an impulse counter directly
- LED pulse output for calibration purposes supplies average active power information
- Configurable for different meter ratings
- Unidirectional or bidirectional power and energy measurement
- Precision on-chip oscillator (70ppm/°C drift)
- Precision on-chip voltage reference (10ppm/°C drift)
- Selectable on-chip anti-creep function (0.01% of F_{MAX} , 0.004% of F_{MAX} , disabled)
- Anti-creep state indicator pin
- Low power consumption (<20mW typical)
- Measures AC inputs only

DESCRIPTION

The SAMES SA4106A is an accurate single phase power/energy metering integrated circuit providing a single chip solution for single phase energy meters. Very few external components are required and the chip includes a direct drive capability for electro-mechanical counters. The SA4106A does not require an external crystal or voltage reference. A precision oscillator and a precision voltage reference to supply the circuitry with a stable frequency and stable reference currents are integrated on the chip.

The SA4106A metering integrated circuit generates a pulse output, the frequency of which is proportional to the active power consumption.

Programmable inputs allow the meter manufacturer to configure the SA4106A for different meter maximum

currents (I_{MAX}) and nominal voltages (V_{NOM}) without having to change the stepper motor counter or impulse counter gear ratio. The LED pulse output follows the average active power consumption measured and is intended for meter calibration purposes. In fast calibration mode this output provides a high frequency pulse rate following the average active power consumption and can be used for fast calibration or to interface with a micro-controller.

The SA4106A includes an anti-creep feature preventing any creep effects in the meter under no-load conditions. The anti-creep threshold can be set to 0.01% or 0.004% of F_{MAX} . The anti-creep function can also be disabled.

The SA4106A integrated circuit is available in a 20-pin small outline (SOIC20) RoHS compliant package.

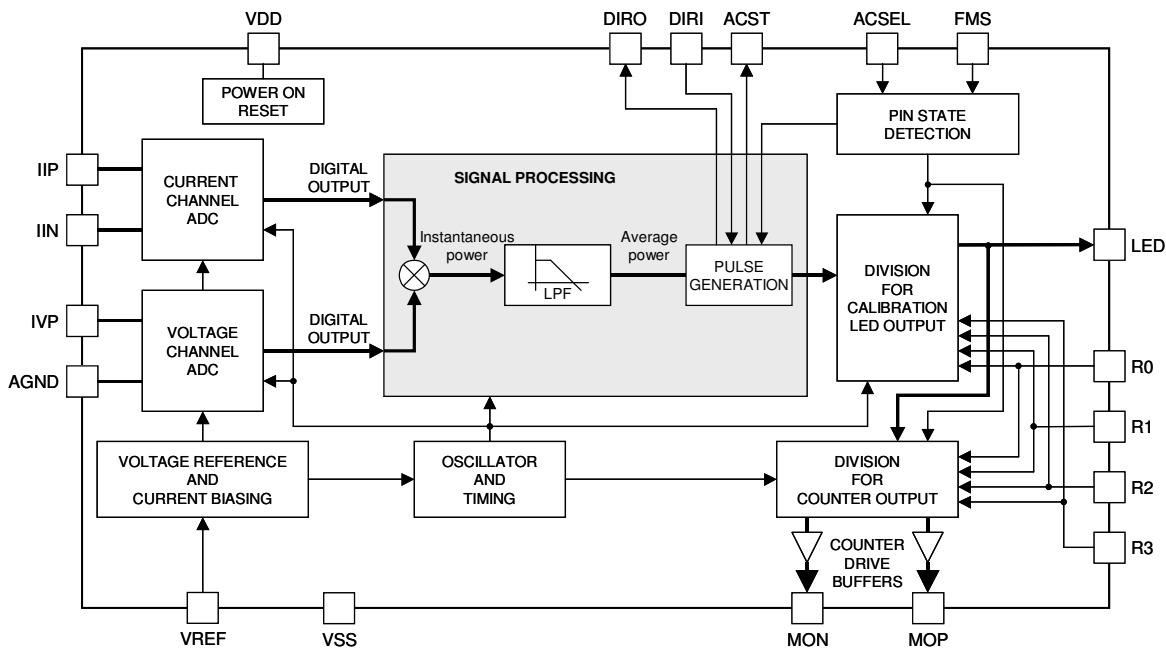

Figure 1: Block diagram

**ELECTRICAL CHARACTERISTICS**

($V_{DD} - V_{SS} = 5V \pm 10\%$, over the temperature range -40°C to $+85^{\circ}\text{C}$, unless otherwise specified. Refer to Figure 2 “Test circuit for electrical characteristics”.)

Parameter	Symbol	Min	Typ	Max	Unit	Condition
General						
Supply Voltage: Positive	V_{DD}	2.25	2.5	2.75	V	With respect to AGND
Supply Voltage: Negative	V_{SS}	-2.75	-2.5	-2.25	V	With respect to AGND
Supply Current: Positive	I_{DD}		3.6	4.6	mA	
Supply Current: Negative	I_{SS}		-3.6	-4.6	mA	
Analog Inputs						
Current Sensor Inputs (Differential)						
Input Current Range	I_{RIIP}, I_{RIIN}	-25		25	μA	Peak value
Offset Voltage	V_{OIIIP}, V_{OIIIN}	-4		4	mV	With $R = 4.7\text{k}\Omega$ connected to AGND
Voltage Sensor Inputs (Asymmetrical)						
Input Current Range	I_{RIVP}	-25		25	μA	Peak value
Offset Voltage	V_{OIVP}	-4		4	mV	With $R = 4.7\text{k}\Omega$ connected to AGND
Digital Inputs						
Pull-up/down Current on FMS, ACSEL*	I_{PUD}	1.5		5.5	mA	
State Change Detection Time for Digital Inputs	T_{ST}			10	ms	
R0, R1, R2, R3, FMS, ACSEL						
Input High Voltage	V_{IH}	$V_{DD}-1$			V	
Input Low Voltage	V_{IL}			$V_{SS}+1$	V	
Digital Outputs						
LED Output Frequency in FAST Mode	F_{MAX}	4.5	5	5.5	kHz	$16\mu\text{A}_{RMS}$ input current per channel
LED, DIRO, ACST						
Output High Voltage	V_{OH}	$V_{DD}-1$			V	$I_{SOURCE} = 5\text{mA}$
Output Low Voltage	V_{OL}			$V_{SS}+1$	V	$I_{SINK} = 5\text{mA}$
MOP, MON						
Output High Voltage	V_{OH}		$V_{DD}-1$		V	$I_{SOURCE} = 10\text{mA}$
Output Low Voltage	V_{OL}		$V_{SS}+1$		V	$I_{SINK} = 10\text{mA}$

* This is the actual pull-up/down current during pin state scanning which is active for $70\mu\text{s}$ every 10ms. The average pull-up/down current is therefore between $10\mu\text{A}$ and $40\mu\text{A}$.

During manufacturing, testing and shipment we take great care to protect our products against potential external environmental damage such as Electrostatic Discharge (ESD). Although our products have ESD protection circuitry, permanent damage may occur on products subjected to high-energy electrostatic discharges accumulated on the human body and/or test equipment that can discharge without detection. Therefore, proper ESD precautions are recommended to avoid performance degradation or loss of functionality during product handling.

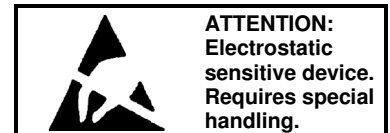



ELECTRICAL CHARACTERISTICS (continued)

($V_{DD} - V_{SS} = 5V \pm 10%$, over the temperature range $-40^{\circ}C$ to $+85^{\circ}C$, unless otherwise specified. Refer to Figure 2 “Test circuit for electrical characteristics”.)

Parameter	Symbol	Min	Typ	Max	Unit	Condition
On-chip Voltage Reference						
Reference Voltage	V_R	1.15	1.20	1.25	V	
Reference Current	$-I_R$	24.4	25.5	26.6	μA	With $R = 47k\Omega$ connected to V_{SS}
Temperature Coefficient	TC_R		10	70	ppm/ $^{\circ}C$	
On-chip Oscillator						
Oscillator Frequency	f_{OSC}	3.15	3.57	4.00	MHz	
Temperature Coefficient	TC_{OSC}		70	200	ppm/ $^{\circ}C$	

ABSOLUTE MAXIMUM RATINGS*

Parameter	Symbol	Min	Max	Unit
Supply Voltage	$V_{DD} - V_{SS}$		6	V
Current on any Pin	I_{PIN}	-150	150	mA
Storage Temperature	T_{STG}	-60	+125	$^{\circ}C$
Specified Operating Temperature Range	T_O	-40	+85	$^{\circ}C$
Limit Range of Operating Temperature	T_{limit}	-40	+85	$^{\circ}C$

*Stresses above those listed under “Absolute Maximum Ratings” may cause permanent damage to the device. This is a stress rating only. Functional operation of the device at these or any other condition above those indicated in the operational sections of this specification, is not implied. Exposure to Absolute Maximum Ratings for extended periods may affect device reliability.

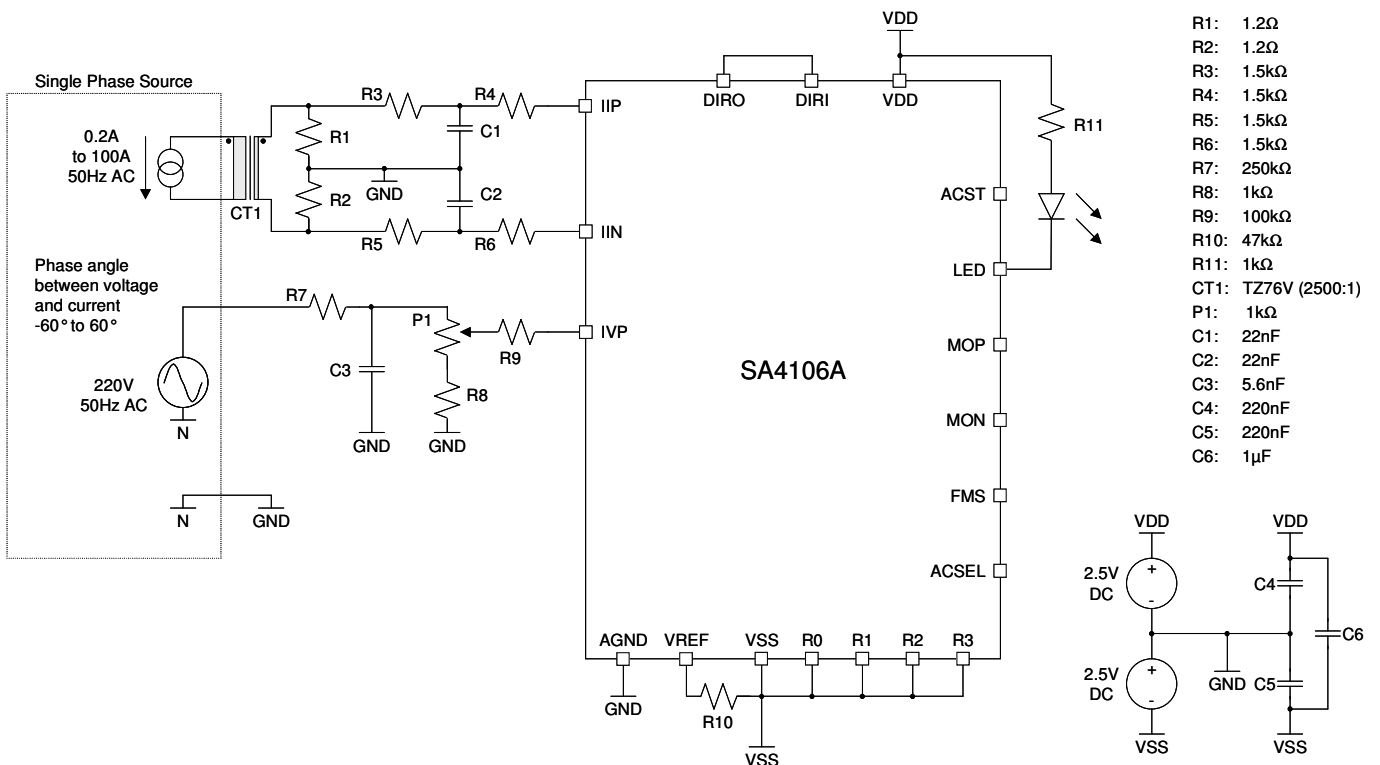

Figure 2: Test circuit for electrical characteristics

**PIN DESCRIPTION**

Designation	Pin No.	Description
AGND	20	Analog Ground. This is the reference pin for the current and voltage signal sensing networks. The supply voltage to this pin should be mid-way between V_{DD} and V_{SS} .
V_{DD}	8	Positive Supply Voltage. The voltage to this pin should be $+2.5V \pm 10\%$ with respect to AGND.
V_{SS}	14	Negative Supply Voltage. The voltage to this pin should be $-2.5V \pm 10\%$ with respect to AGND.
IVP	19	Analog Input for Voltage. The maximum current into the voltage sense input IVP should be set at $16\mu A_{RMS}$. The voltage sense input saturates at an input current of $\pm 25\mu A$ peak.
IIP, IIN	2, 1	Analog Inputs for Current. The maximum current into the current sense inputs IIP/IIN should be set at $16\mu A_{RMS}$. The current sense inputs saturate at an input current of $\pm 25\mu A$ peak.
VREF	3	This pin provides the connection for the reference current setting resistor. A $47k\Omega$ resistor connected to V_{SS} sets the optimum operating conditions.
R0, R1, R2, R3	6, 5, 4, 11	Rated Condition Select inputs. These input pins are used for selecting between the different rated condition configurations. Refer to the Rated Condition Select section.
FMS	7	Fast Mode Select input. This three state input is used to select between STANDARD and FAST mode and provides an extended selection of meter constants. Refer to the Rated Condition Select and Fast Mode Select sections.
DIRI	18	Direction Select input. This input is used to enable either bidirectional or unidirectional energy measurement.
ACSEL	9	Anti-Creep Threshold Select input. This three state input is used to select the anti-creep threshold. It is also used to deactivate the anti-creep feature. Refer to the Anti-Creep Threshold Select section.
ACST	16	Anti-Creep State output. This output pin indicates the state of the anti-creep circuit. Refer to the Anti-Creep State Output section.
DIRO	17	Direction Indicator output. This output indicates the direction of energy flow.
LED	13	Calibration LED output. Refer to the Rated Condition Select section for the pulse rate output options.
MON, MOP	15, 12	Motor pulse outputs. These outputs can drive an electro-mechanical counter directly. Refer to the Rated Condition Select section for the pulse rate output options.
NC	10	No connection.

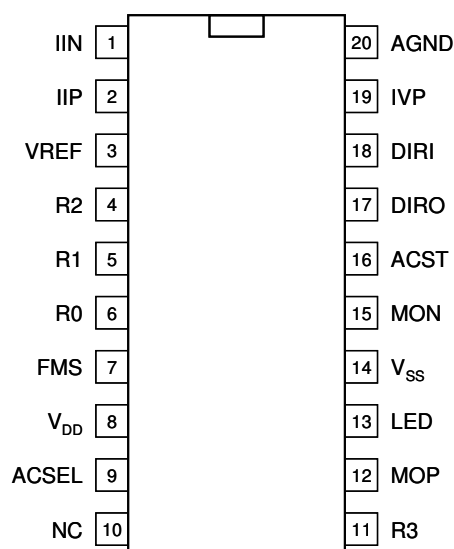

Figure 3: Pin connections

ORDERING INFORMATION

Part Number	Package
SA4106ASAR	SOIC20 (RoHS compliant)



TERMINOLOGY

Anti-Creep Threshold

The anti-creep threshold is defined as the minimum energy threshold below which no energy is registered and therefore no pulses are generated on the LED or motor drive outputs.

Positive Energy

Positive energy is defined when the phase difference between the input signals IIP and IVP is less than 90 degrees (-90..90 degrees).

Negative Energy

Negative energy is defined when the phase difference between the input signals IIP and IVP is greater than 90 degrees (90..270 degrees).

Percentage Error*

Percentage error is given by the following formula:

$$\%Error = \frac{\text{Energy registered by device} - \text{True Energy}}{\text{True Energy}} \times 100$$

NOTE: Since the true value cannot be determined, it is approximated by a value with a stated uncertainty that can be traced to standards agreed upon between manufacturer and user or to national standards.

Rated Operating Conditions*

Set of specified measuring ranges for performance characteristics and specified operating ranges for influence quantities, within which the variations or operating errors of a meter are specified and determined.

Specified Measuring Range*

Set of values of a measured quantity for which the error of a meter is intended to lie within specified limits.

Specified Operating Range*

A range of values of a single influence quantity, which forms a part of the rated operating conditions.

Limit Range of Operation*

Extreme conditions which an operating meter can withstand without damage and without degradation of its metrological characteristics when it is subsequently operated under its rated operating conditions.

Maximum Rated Mains Current (I_{MAX})

Maximum rated mains current is the specified maximum current flowing through the energy meter at rated operating conditions.

Constant*

Value expressing the relation between the active energy registered by the meter and the corresponding value of the test output. If this value is a number of pulses, the constant should be either pulses per kilowatt-hour (imp/kWh) or watt-hours per pulse (Wh/imp).

Nominal Mains Voltage (V_{NOM})

Nominal mains voltage (V_{NOM}) is the voltage specified for the energy meter at rated operating conditions.

Maximum Output Frequency (F_{MAX})

The maximum output frequency (F_{MAX}) is the output frequency in FAST mode when $16\mu A_{RMS}$ input current with zero phase shift are applied to the voltage and current inputs. Both the voltage and current inputs saturate at an input current magnitude of $25\mu A$, or at $17.68\mu A_{RMS}$ when using sine waves. The maximum input current on each channel is therefore defined to be $16\mu A_{RMS}$, which leaves about 10% headroom to the saturation point. In FAST mode the nominal maximum output frequency of 5kHz is achieved under such conditions.

Repeatability of Error Test**

This test shall be carried out at 0.05lb and lb at UPF load under reference test conditions. Twenty error samples shall be taken at time intervals of 30 minutes. Identical test conditions shall be maintained throughout the test. For an acceptance test six error tests may be carried out at time intervals of at least 5 minutes.

* IEC 62052-11, 2003. Electricity Metering Equipment (AC) – General Requirements, Test and Test Conditions – Part 11: Metering Equipment

** IS13779-1999 Indian Standard AC Static Watt-hour Meters Class 1 and 2 Specification Rev 1



PERFORMANCE GRAPHS

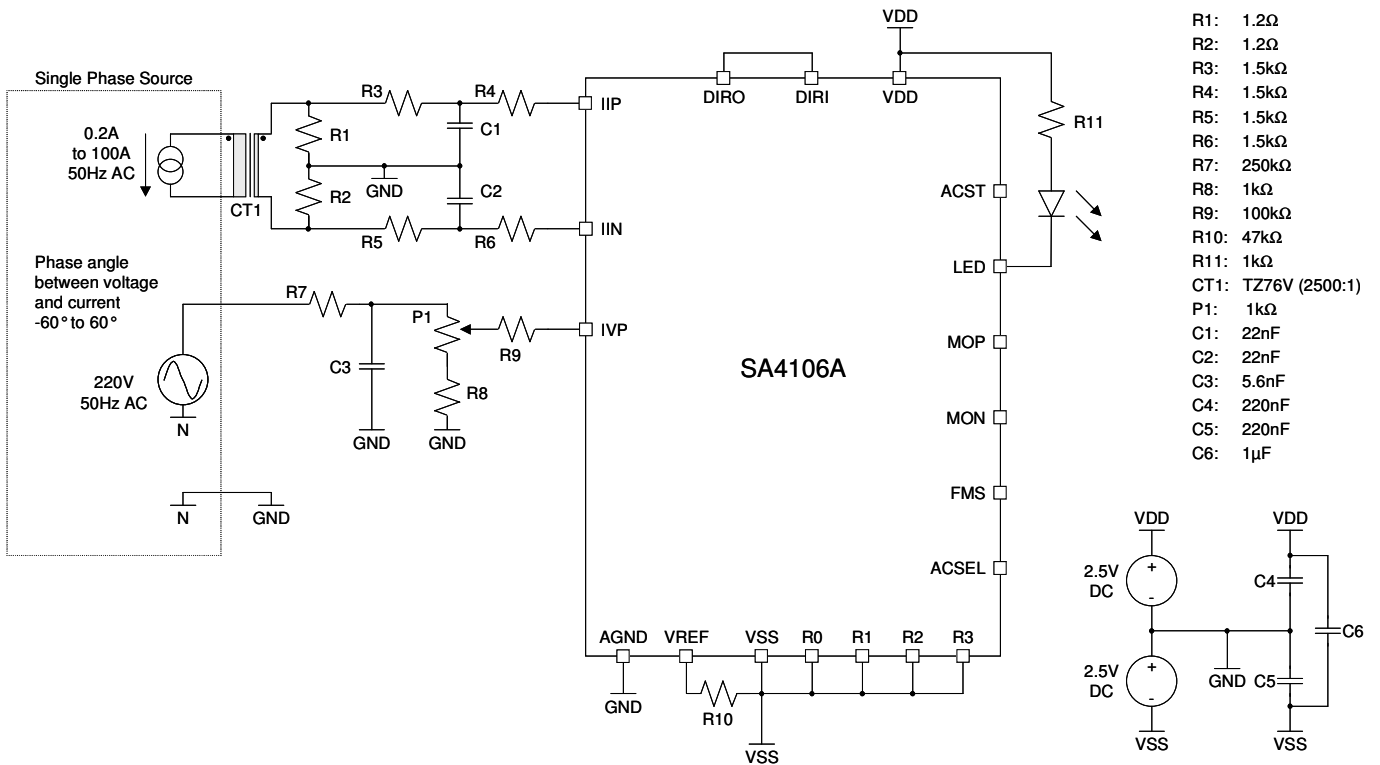
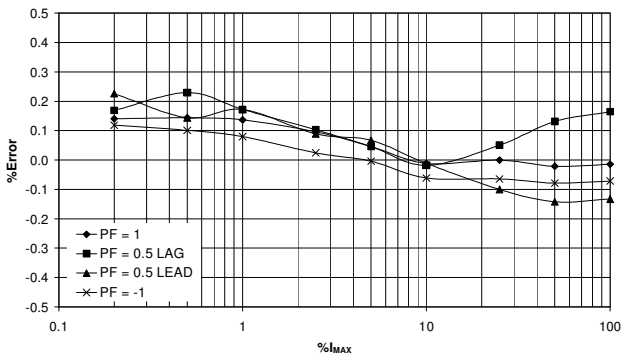
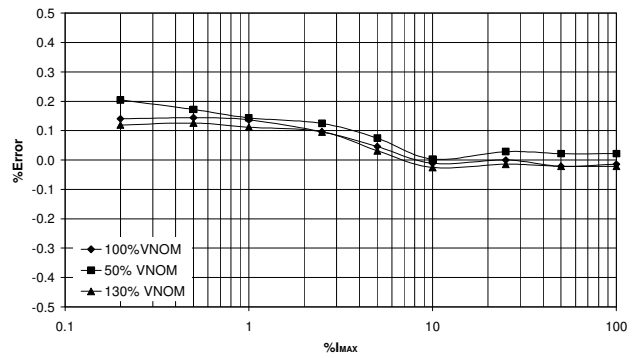

Figure 4: Test circuit for performance graphs



GRAPH 1 - Freq = 50Hz, V_{NOM} , Temp = 25 °C, $V_{DD}-V_{SS} = 5.0V$



GRAPH 2 - PF = 1, Freq = 50Hz, Temp = 25 °C, $V_{DD}-V_{SS} = 5.0V$

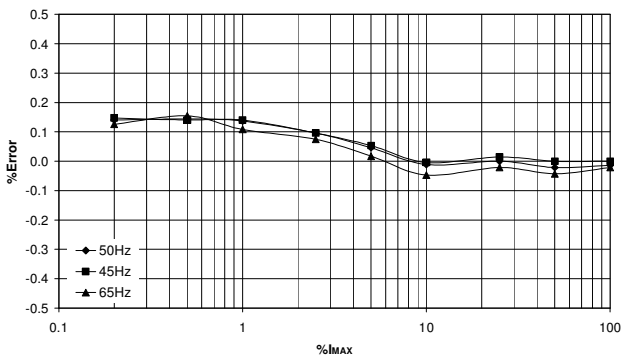

GRAPH 3 - PF = 1, V_{NOM} , Temp = 25 °C, $V_{DD}-V_{SS} = 5.0V$

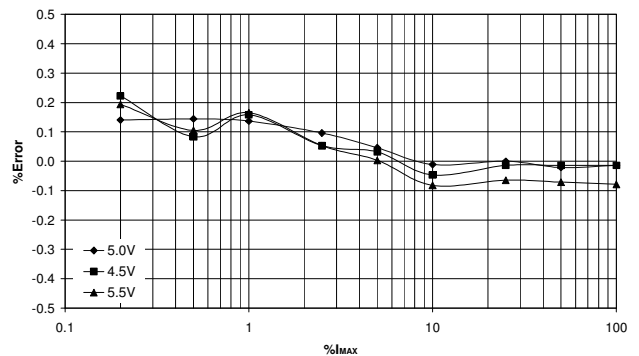

GRAPH 4 - PF = 1, Freq = 50Hz, V_{NOM} , Temp = 25 °C



FUNCTIONAL DESCRIPTION

Theory of Operation

The SA4106A includes all the required functions for single channel single phase power and energy measurement. Two AD converters sample the voltage and current input signals. The two digital signals, accurately representing the voltage and current inputs, are multiplied using digital multiplication. The output of the multiplier represents the instantaneous power, which is subsequently low pass filtered and integrated over time to remove the instantaneous components forming the averaged instantaneous energy. This energy is accumulated over time to form the outputs of the device.

For given voltage and current signals the instantaneous power is calculated by:

$$p(t) = v(t) \times i(t)$$

$$p(t) = V_M \cos(\omega t + \theta) \times I_M \cos(\omega t + \psi)$$

$$\text{Let } \phi = \theta - \psi, \text{ and } V_{RMS} = \frac{V_M}{\sqrt{2}} \text{ and } I_{RMS} = \frac{I_M}{\sqrt{2}} \text{ then}$$

$$p(t) = V_M \cos(\omega t + \theta) \times I_M \cos(\omega t + \theta - \phi)$$

$$p(t) = V_{RMS} I_{RMS} (\cos \phi - \cos(2(\omega t + \theta) - \phi))$$

where

$p(t)$ is the instantaneous power,

$v(t)$ is the instantaneous voltage signal,

$i(t)$ is the instantaneous current signal,

V_M is the amplitude of the voltage signal,

I_M is the amplitude of the current signal,

θ is the phase angle of the voltage signal and

ψ is the phase angle of the current signal.

The instantaneous power is low pass filtered to remove the double mains frequency component $\cos(2(\omega t + \theta) - \phi)$ and is then integrated over time to provide the average power information

$$P = \frac{1}{T} \int_0^T p(t) dt$$

$$P = V_{RMS} I_{RMS} \cos \phi$$

where

P is the average power and

$\cos \phi$ is the power factor.

Linearity

The SA4106A is a CMOS integrated circuit, which performs power/energy calculations across a dynamic range of 500:1 to an accuracy that exceeds the IEC62053 specification.

Analog Inputs

The input circuitry of the current and voltage sensor inputs is illustrated in Figure 5. These inputs are protected against electrostatic discharge through clamping diodes. The feedback loops from the outputs of the amplifiers A_I and A_V generate virtual short circuits between IIP and IIN as well as IVP and AGND. The current sense inputs (IIP and IIN) are identical and balanced. The AD converters convert the signals on the voltage and current sense inputs to a digital format for further processing. All internal offsets are eliminated through the use of various cancellation techniques.

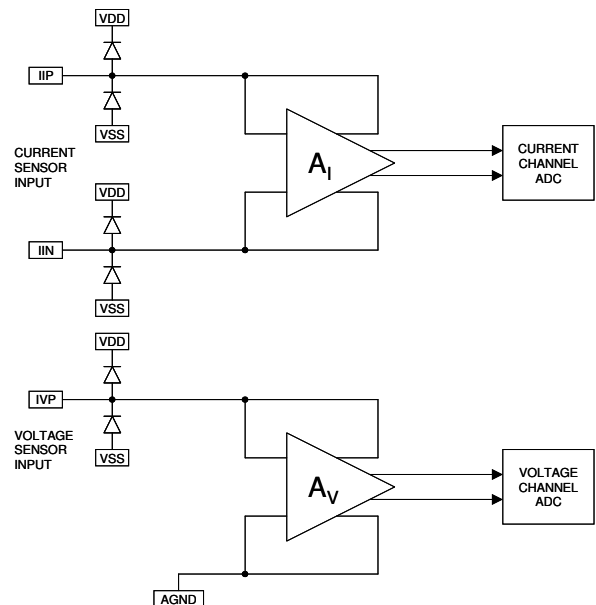

Figure 5: Analog input configuration

Digital Outputs

The calculations required for power and energy are performed and converted to pulses on the LED, MON and MOP outputs. The complimentary output pins MON and MOP are provided for driving a stepper motor counter directly. The output frequency on the LED output is, in both STANDARD and FAST mode, proportional to the average active power consumption measured. The FAST mode is intended for fast meter calibration and verification purposes or for interfacing the SA4106A to a micro-controller.

Anti-Creep Threshold

An integrated anti-creep function prevents any output pulses on the LED output and the MON/MOP motor drive outputs when the level of measured energy is below the anti-creep threshold. This threshold is selectable between 0.01% and



0.004% of F_{MAX} , where F_{MAX} is the output frequency in FAST mode when the input currents are $I_{VP_{MAX}} = 16\mu A_{RMS}$ and $I_{IP_{MAX}} = 16\mu A_{RMS}$. The anti-creep function can also be disabled. The operation of the anti-creep function is fully described in the Input Signals and Output Signals sections.

Reverse Energy Flow Indication

The SA4106A assesses the phase difference between the voltage channel signal and the current channel signal. If this phase difference is greater than 90 degrees then the DIRO signal will become active. This facility is designed to detect the wrongful connection of the meter. This operation is fully described in the Output Signals section.

Starting Current

The SA4106A generates pulses on the LED and MON/MOP outputs for an input power greater than 0.01% or 0.004% of F_{MAX} depending on the selected anti-creep threshold. This is to comply with the IEC requirement where the meter is required to generate pulses for currents greater than 0.4%Ib.

Calibration and Repeatability

The SA4106A provides an output (LED) that is used for calibration of the meter. The meter is calibrated by comparing the energy reading of the meter under test with the energy reading of the reference meter. The reference meter should have a considerably higher pulse rate than the meter under test. The accuracy to which the meter has to be calibrated will dictate how much higher the reference meter

pulse rate has to be. The SA4106A can be calibrated to specification with a minimum of two pulses on the LED output whilst in STANDARD mode and utilizing an appropriate reference meter. This reading is independent of time and will be repeatable so as to consistently achieve the required accuracy for the full input current range that needs to be measured to IEC62053 accuracy. In Figure 6 the reference meter pulses are counted between two pulses of the meter under test. The meter under test is then adjusted so as to reflect the expected number of counted reference meter pulses. A worst-case scenario is for measurements obtained for only two pulses of the meter under test and N pulses from the reference meter. In this case the measurement resolution will be:

$$\text{Measurement Resolution (\%)} = \frac{1}{N} \times 100$$

The corresponding calibration and repeatability results can never be more accurate than this measurement resolution.

Power-On Reset

The SA4106A has a power-on reset circuitry that activates whenever the voltage between V_{DD} and V_{SS} is less than $3.6V \pm 8\%$.

Power Consumption

The power consumption of the SA4106A integrated circuit is less than 30mW.

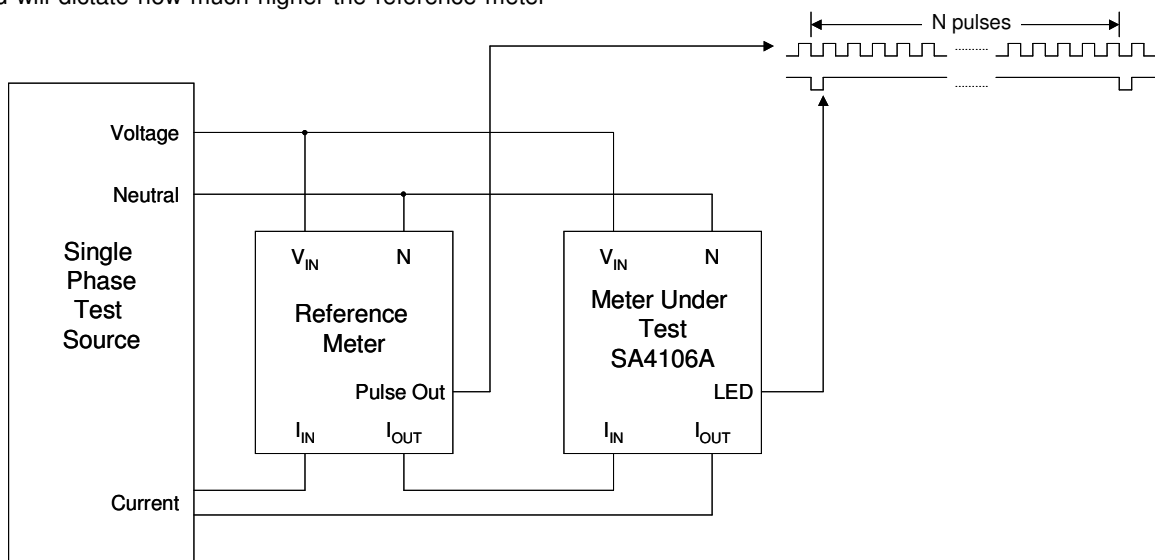

Figure 6: Calibration and repeatability setup



INPUT SIGNALS

Voltage Reference (VREF)

A bias resistor of 47kΩ sets optimum bias and reference conditions on chip. Calibration of the SA4106A should be done on the voltage input and not on the VREF input.

Current Sense Inputs (IIP and IIN)

Figure 7 shows the typical connections for the current sensor input when using a shunt or a current transformer as a current sensing element. At maximum rated mains current (I_{MAX}) the resistor values should be selected for an input current of $16\mu A_{RMS}$. The current sense inputs saturate at an input current of $\pm 17.6\mu A_{RMS}$ ($\pm 25\mu A_{PEAK}$), so this allows about 10% headroom until saturation occurs.

The resistor RSH is the shunt resistor. The voltage drop across RSH as maximum rated mains current (I_{MAX}) should not be less than $5mV_{RMS}$ and not exceed $100mV_{RMS}$.

The resistors RA and RB form the current transformers termination resistor. The reference level is connected in the centre of the termination resistor to achieve purely differential input currents. The voltage drop across the termination resistors at maximum rated mains current (I_{MAX}) should be in the order of $100mV_{RMS}$. The termination resistance should also be significantly smaller than the DC resistance of the current transformers secondary winding.

The resistors R1 to R4 define the current flowing into the device. For best performance the SA4106A requires anti-alias filters on the current sense inputs. These filters are realized by means of the capacitors C1 and C2. The typical cut-off frequency of these filters should be between 10kHz and 20kHz. The optimum input network is achieved by setting the input resistors equal, i.e. setting $R1 = R2 = R3 = R4 = R_C$. This sets the equivalent resistance associated with each capacitor to $R_C/2$.

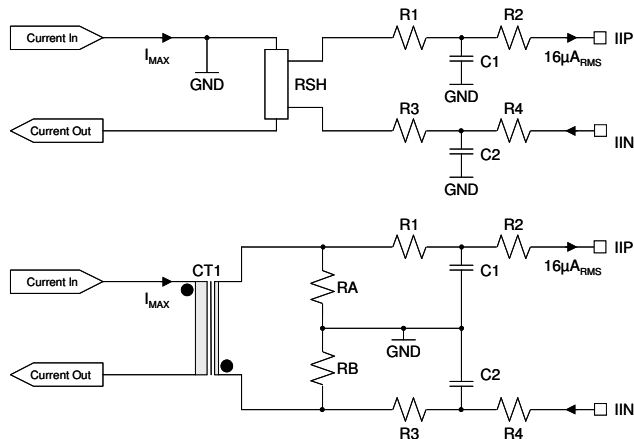

Figure 7: Current sense input configuration

Voltage Sense Input (IVP)

Figure 8 shows the voltage sense input configuration. The voltage sense input saturates at an input current of $\pm 17.6\mu A_{RMS}$ ($\pm 25\mu A_{PEAK}$). The current into the voltage sense input should therefore be set between $11\mu A_{RMS}$ and $12\mu A_{RMS}$ at nominal mains voltage (V_{NOM}) to allow for a mains voltage variation of up to +30% and -50% without saturating the voltage sense input. Typical V_{NOM} values and the corresponding IVP input currents are shown in the following table.

Table 1: IVP input current for typical values of V_{NOM}

V_{NOM} (V)	IVP Input Current (μA_{RMS})
110 / 220	11
115 / 230	11.5
120 / 240	12

For best performance the SA4106A also requires an anti-alias filter on the voltage sense input. Referring to Figure 8, the capacitor C1 is used to implement the anti-alias filter. If a current transformer is used as a current sensing element then C1 is also used to compensate for any phase shift caused by the current transformer. The resistor R4 defines the input current into the device. The optimum input network is achieved by setting R4 smaller than $100k\Omega$. If R4 is made too large the capacitor C1 will be very small and the phase shift of the input network could be affected by stray capacitances. The potentiometer P1 is used for calibration purposes.

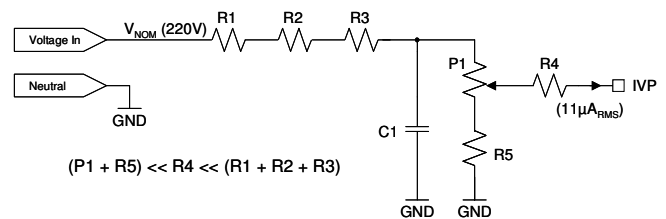

Figure 8: Voltage sense input configuration

**Direction Select Input (DIRI)**

Depending on the state of the DIRI pin the energy to be measured can be positive energy only, negative energy only, or both positive and negative energy. Connecting DIRI to V_{DD} will result in only positive energy being measured. Energy flowing in the negative direction will not be measured. Connecting DIRI to V_{SS} will result in only negative energy being measured. Energy flowing in the positive direction will not be measured. Connecting the DIRI pin to the DIRO output pin enables the bidirectional mode where energy is measured regardless of direction.

Anti-Creep Threshold Select (ACSEL)

The Anti-Creep Threshold Select input (ACSEL) is used to select between different anti-creep thresholds. The thresholds that can be selected are shown in Table 2. The anti-creep feature can also be disabled if required. In this case an external micro-controller could be used to implement any desirable anti-creep threshold.

Table 2: Anti-creep threshold selection via the ACSEL input

ACSEL Input	Anti-Creep Threshold
V_{SS}	Disabled
V_{DD}	0.01% F_{MAX}
Floating	0.004% F_{MAX}

The anti-creep threshold is defined as a percentage of the maximum output frequency in FAST mode (F_{MAX}). Any FAST mode pulses that occur at a lower frequency are not passed to the pulse dividers and pulse output circuits.

Fast Mode Select (FMS)

The Fast Mode Select input (FMS) is used to select between STANDARD and FAST mode as well as to select between a multitude of meter constants and motor drive dividing ratios. Connecting this pin to V_{DD} or V_{SS} enables the STANDARD mode of operation while leaving this pin floating enables the FAST mode of operation. When STANDARD mode is enabled the LED output pulses at a low frequency. This low frequency allows a longer accumulation period and the output pulse rate is therefore proportional to the average power consumption measured.

The Rated Condition Select pins (R0, R1, R2, R3) together with the FMS pin are used to select different LED output frequencies which in turn determine the applications meter constant. Refer to Figure 9 for the LED output timing diagram. When the FAST mode is enabled the LED output generates pulses at a nominal frequency of 5kHz at I_{MAX} and V_{MAX} . In this mode the pulse frequency is proportional to the average power consumption measured. This mode is useful when interfacing to a micro-controller.

When FMS is floating the LED pin outputs fast mode pulses. The motor pulses occur as usual based on the last FMS before a floating condition was detected as well as the current states of R0, R1, R2 and R3. If a floating condition on FMS is detected at device start-up the motor pulses are generated based on FMS set to V_{SS} .

Rated Condition Select (R0, R1, R2, R3)

The Rated Condition Select inputs (R0, R1, R2 and R3) along with the Fast Mode Select input (FMS) are used for obtaining a multitude of meter constants and motor drive ratios. The different LED and motor division factors (DF_LED and DF_MO) that can be selected via R0, R1, R2, R3 and FMS are shown Table 3.

To calculate the LED output pulse constant in STANDARD mode and the motor drive pulse constant for any meter rating (I_{MAX} and V_{NOM}) the following formulae can be used:

$$\text{LED imp/kWh} = \frac{\text{IVP}}{16} \times \frac{5000}{\text{DL_LED}} \times \frac{1000 \times 3600}{V_{NOM} \times I_{MAX}} \quad (1)$$

where

I_{MAX} = maximum rated mains current,

V_{NOM} = nominal mains voltage,

IVP = the analog input current on the voltage sense input at V_{NOM} as specified in Table 1 and

DF_LED = the dividing factor for the LED output that is set by the combination of R0, R1, R2, R3 and FMS as specified in Table 3.

Equation 1 is based on the assumption that the input current into the IIP/IIN current sense input is set to $16\mu\text{A}_{RMS}$ at I_{MAX} .

$$\text{Motor imp/kWh} = \frac{\text{LED imp/kWh}}{\text{DF_MO}} \quad (2)$$

where

LED imp/kWh = the LED constant as calculated using Equation 1 and

DF_MO = the dividing factor for the motor output that is set by the combination of R0, R1, R2, R3 and FMS as specified in Table 3.

Table 4 illustrates some of the possible LED and motor constants that are achievable for some common values of I_{MAX} using a V_{NOM} between 220V and 240V.



Table 3: LED and motor division factors

FMS	R3	R2	R1	R0	DF_LED	DF_MO
0	0	0	0	0	220	256
0	0	0	0	1	440	128
0	0	0	1	0	880	64
0	0	0	1	1	1760	32
0	0	1	0	0	220	128
0	0	1	0	1	440	64
0	0	1	1	0	880	32
0	0	1	1	1	1760	16
0	1	0	0	0	220	64
0	1	0	0	1	440	32
0	1	0	1	0	880	16
0	1	0	1	1	1760	8
0	1	1	0	0	220	32
0	1	1	0	1	440	16
0	1	1	1	0	880	8
0	1	1	1	1	1760	4
1	0	0	0	0	1464	64
1	0	0	0	1	2928	32
1	0	0	1	0	352	64
1	0	0	1	1	704	32
1	0	1	0	0	584	32
1	0	1	0	1	1168	16
1	0	1	1	0	352	32
1	0	1	1	1	704	16
1	1	0	0	0	584	16
1	1	0	0	1	1168	8
1	1	0	1	0	352	16
1	1	0	1	1	704	8
1	1	1	0	0	292	16
1	1	1	0	1	584	8
1	1	1	1	0	234	16
1	1	1	1	1	468	8

Note: Pin values defined as follows
 0 pin is connected to V_{SS}
 1 pin is connected to V_{DD}

Table 4: LED and motor constants achievable for some common I_{MAX} currents for V_{NOM} = 220V to 240V

I _{MAX} (A)	Dividing Factors		LED Output (imp/kWh)	Motor Output (imp/kWh)
	DF_LED	DF_MO		
6	1464	64	6400	100
6	2928	32	3200	100
10	220	256	25600	100
10	440	128	12800	100
10	880	64	6400	100
10	1760	32	3200	100
10	220	128	25600	200
10	440	64	12800	200
10	880	32	6400	200
10	1760	16	3200	200
10	220	64	25600	400
10	440	32	12800	400
10	880	16	6400	400
10	1760	8	3200	400
10	220	32	25600	800
10	440	16	12800	800
10	880	8	6400	800
10	1760	4	3200	800
20	220	128	12800	100
20	440	64	6400	100
20	880	32	3200	100
20	1760	16	1600	100
20	220	64	12800	200
20	440	32	6400	200
20	880	16	3200	200
20	1760	8	1600	200
20	220	32	12800	400
20	440	16	6400	400
20	880	8	3200	400
20	1760	4	1600	400
25	352	64	6400	100
25	704	32	3200	100
25	352	32	6400	200
25	704	16	3200	200
25	352	16	6400	400
25	704	8	3200	400



Table 4: continued

I _{MAX} (A)	Dividing Factors		LED Output (imp/kWh)	Motor Output (imp/kWh)
	DF_LED	DF_MO		
30	584	32	3200	100
30	1168	16	1600	100
30	584	16	3200	200
30	1168	8	1600	200
30	292	16	6400	400
30	584	8	3200	400
40	220	64	6400	100
40	440	32	3200	100
40	880	16	1600	100
40	1760	8	800	100
40	220	32	6400	200
40	440	16	3200	200
40	880	8	1600	200
40	1760	4	800	200
50	352	32	3200	100
50	704	16	1600	100
50	352	16	3200	200
50	704	8	1600	200
60	584	16	1600	100
60	1168	8	800	100
60	292	16	3200	200
60	584	8	1600	200
80	220	32	3200	100
80	440	16	1600	100
80	880	8	800	100
80	1760	4	400	100
100	352	16	1600	100
100	704	8	800	100
120	292	16	1600	100
120	584	8	800	100
150	234	16	1600	100
150	468	8	800	100

OUTPUT SIGNALS

LED Output (LED)

The LED output pin provides a pulse output with a frequency proportional to the average active energy consumption measured when in STANDARD mode or FAST mode. A low pass filter is applied to the instantaneous energy output directly after multiplication. This filtering allows all instantaneous components to be removed resulting in a constant output frequency at constant energy input, even over a short period of time. The delay of this filter is about 200ms.

The LED output is primarily used for calibration purposes. The Rated Condition Select inputs (R0, R1, R2, R3) and the Fast Mode Select input (FMS) allow different nominal output frequencies to be selected. The FMS input also allows selection between STANDARD mode and FAST mode. The LED output is active low. Figure 9 shows the LED output waveform.

In FAST mode the LED pulse output is set to a nominal frequency of 5kHz at an input current of 16μA_{RMS} on both the current and voltage channels.

The nominal output frequency of the LED pin is given by

$$f_{LED_FAST} = 5000 \times \frac{IVP \times IIP \times |\cos \phi|}{16^2} \tag{3}$$

in FAST mode and by

$$f_{LED_STD} = \frac{f_{LED_FAST}}{DF_LED} \tag{4}$$

in STANDARD mode where

IVP and IIP = the analog input currents in μA_{RMS} on the voltage and current sense inputs,
 cosφ = the phase angle between the current and voltage signals and
 DF_LED = the LED divider selected by R0, R1, R2, R3 and FMS according to Table 3.

The timing values given below are based on the nominal frequency value of the internal oscillator.

$$t_L = 1/f_{LED_FAST} \text{ in FAST mode (} f_{LED_FAST} \text{ as per Equation 3)}$$

$$= 1/f_{LED_STD} \text{ in STANDARD mode (} f_{LED_STD} \text{ as per Equation 4)}$$

$$t_{LP} = 91.5\text{ms when } t_L > 183\text{ms in STANDARD mode}$$

$$= t_L/2 \text{ when } t_L < 183\text{ms in STANDARD mode}$$

$$= 69\mu\text{s in FAST mode}$$

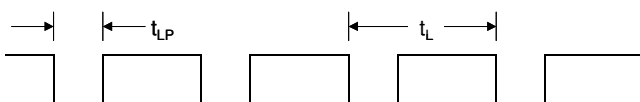

Figure 9: LED pulse output waveform



Motor Pulse Output (MON, MOP)

The MON and MOP pins are complimentary outputs with a frequency proportional to the average active power consumption measured. These active high outputs can be used to either directly drive a stepper motor counter or an electro-mechanical impulse counter. The Rated Condition Select inputs (R0, R1, R2, R3) as well as the Fast Mode Select input (FMS) allow the selection of different output frequencies corresponding to different meter constants. Figure 10 indicates the timing of these signals.

The nominal output frequency of each motor output is given by:

$$f_{MOT} = \frac{f_{LED_STD}}{DF_MO} \tag{5}$$

f_{LED_STD} = the output frequency of the LED output in STANDARD mode as per Equation 4 and
 DF_MO = the motor divider selected by R0, R1, R2, R3 and FMS according to Table 3

When connecting a stepper motor counter between MON and MOP the output pulse rate is effectively doubled because the pulses on both MON and MOP contribute to incrementing the counter.

The timing values given below are based on the nominal frequency value of the internal oscillator.

- $t_M = 1/f_{MOT}$ (f_{MOT} as per Equation 5)
- $t_{MP} = 220ms$ when $t_M > 440ms$
- $t_{MP} = t_M/2$ when $t_M < 440ms$
- $t_{MS} = t_M/2$
- $t_{MSP} = t_{MS} - t_{MP}$ when $t_M > 440ms$
- $t_{MSP} = 6.7\mu s$ when $t_M < 440ms$

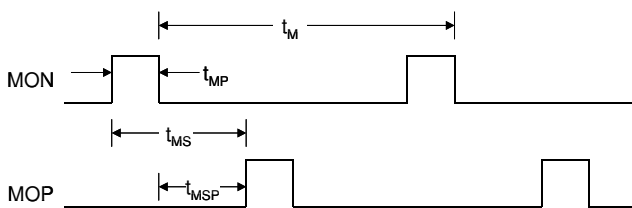

Figure 10: Motor pulse output waveform

Anti-Creep State Output (ACST)

The state of the anti-creep circuit is available on the ACST output pin. This pin allows the state of the anti-creep circuit to be monitored. A logic 0 on this pin indicates that the anti-creep circuit has detected an energy level below the threshold set by the ACSEL pin. In this state no pulses will be emitted on the LED and the motor pulse outputs. A logic 1 indicates that the detected energy is above the anti-creep threshold and pulses will be emitted on the LED and motor pulse outputs. The ACST pin can be used to drive an LED to indicate when the SA4106A has detected energy below or above the anti-creep threshold. A power-on reset will set ACST low and the pin will go high only once energy above the anti-creep threshold has been detected. If the anti-creep threshold is disabled the ACST pin will go high as soon as the logic low on ACSEL has been detected and it will remain high, regardless what level of energy is detected.

Direction Indicator Output (DIRO)

The direction of the energy flow may be ascertained by monitoring the DIRO pin. A logic 0 on this pin indicates negative energy flow. Positive energy flow is indicated by a logic 1. Should the energy (either negative or positive) be less than the anti-creep threshold then this output will retain its previous state. This prevents a flickering output in the case of no or very low current flow. The DIRO pin may be used to drive an LED. The state of the DIRO pin is updated on the internal FAST mode pulses, regardless of whether the device is set to FAST or STANDARD mode and what state DIR1 is set to. A power-on reset will set DIRO high and it will remain high until negative energy above the anti-creep threshold is detected. Table 5 illustrates the operation of the DIRO output.

Table 5: Operation of the DIRO output

Energy Level	Phase Angle	State of DIRO
$< F_{MIN}$	$0^\circ - 360^\circ$	Previous State
$> F_{MIN}$	$< 90^\circ$	HIGH
$> F_{MIN}$	$> 90^\circ$	LOW

Note: F_{MIN} is the anti-creep threshold if enabled



TYPICAL APPLICATION

The following description outlines the basic process required to design a typical single phase energy meter using the SA4106A and a shunt resistor as a current sensing element. The meter is capable of measuring 220V/40A/50Hz with a precision better than Class 1. It uses a stepper motor counter with 100imp/kWh and the calibration LED has a constant of 1600imp/kWh.

The most important external circuits required for the SA4106A are the current input network, the voltage input network as well as the bias resistor. All resistors should be 1% metal film resistors of the same type to minimize temperature effects.

Bias Resistor

A bias resistor of $R_{10} = 47k\Omega$ sets optimum bias and reference currents on chip. Calibration of the meter should be done using the voltage input and not by means of the bias resistor.

Current Input Network

The voltage drop across the shunt resistor at maximum rated current should not be less than $5mV_{RMS}$ and not exceed $100mV_{RMS}$. A $320\mu\Omega$ shunt is chosen which sets the voltage drop at maximum rated current to 12.8mV and the power dissipation in the shunt to 0.5W. The voltage across the shunt resistor is converted to the required differential input currents through the current input resistors. Anti-alias filters are incorporated on these input resistors to filter any high frequency signal components that could affect the performance of the SA4106A.

The four current input resistors (R_1, R_2, R_3, R_4) should be of equal size to optimize the input networks low pass filtering characteristics, so the values can be calculated as follows:

$$R_1 = R_2 = R_3 = R_4 = I_{MAX} \times \frac{R_{SH}}{4 \times 16\mu A} = 200\Omega = R_C.$$

For optimum performance the cut-off frequency of the anti-alias filter should be between 10kHz and 20kHz. The equivalent resistance associated with each capacitor is $R_C/2$ so the capacitor values should be in the order of

$$C_1 = C_2 = \frac{1}{\pi f_{CI} R_C} = \frac{1}{\pi \times 15kHz \times 200\Omega} \approx 100nF$$

where f_{CI} is the cut-off frequency of the anti-alias filter of the current input network.

Voltage Input Network

The voltage sense input requires an input current of $11\mu A_{RMS}$ at V_{NOM} (220V) according to Table 1. The mains voltage is divided by means of a voltage divider to a lower voltage that is converted to the required input current by means of the input resistor. Once again an anti-alias filter is required to remove any high frequency signals that could affect the performance of the SA4106A. A shunt typically has no phase shift so phase compensation is not required.

The input resistor R_8 sets the current input into the device. This resistor should not be too large else the capacitor for the anti-alias filter will be quite small which could cause inaccurate phase shift due to parasitic capacitances. Therefore $R_8 = 100k\Omega$ is chosen and the voltage at the centre of the trimpot should be 1.1V ($11\mu A \times 100k\Omega$). The calibration range of the voltage input network should be about $\pm 15\%$ to ensure that all component tolerances can be catered for, so the total tuning range can be set to $\pm 0.17V$. Therefore the voltage across the trimpot and R_9 is 1.27V. Choosing a $1k\Omega$ trimpot results in

$$R_9 = \frac{1k\Omega}{(2 \times 0.17)} \times (1.27 - 2 \times 0.17) \approx 2.7k\Omega.$$

The effect of R_8 can be ignored in the above equation, given the fact that R_8 is significantly larger than P_1 and R_9 . Now let $R_A = R_5 + R_6 + R_7$ and

$$R_A = (P_1 + R_9) \times \left(\frac{220V}{1.27V} - 1 \right) \approx 637k\Omega$$

so choose $R_5 = 240k\Omega$, $R_6 = 220k\Omega$ and $R_7 = 180k\Omega$.

The cut-off frequency of the anti-alias filter is adjusted so that it is identical to that of the current input network anti-alias filters. This ensures that the phase shift caused by the anti-alias filters is identical on the current and voltage input networks. Therefore

$$\frac{1}{\pi C_1 \times R_C} = \frac{1}{2\pi(P_1 + R_8) \times C_3}$$

and so $C_3 = 2.7nF$.



Device Setup

The SA4106A has to be set to STANDARD mode. Using Equations 1 and 2 in the Rated Condition Select section the required LED and motor dividers for 1600imp/kWh and 100imp/kWh respectively are calculated as DF_LED = 880 and DF_MO = 16. Using Table 3 the device is set up using FMS = V_{SS}, R3 = V_{DD}, R2 = V_{SS}, R1 = V_{DD} and R0 = V_{SS}.

The lowest possible creep limit is chosen to allow the meter to register energy at very low currents, so ACSEL is left floating. In order to obtain the highest immunity against tampering the SA4106A is set up to measure bidirectional energy by connecting DIRI to DIRO.

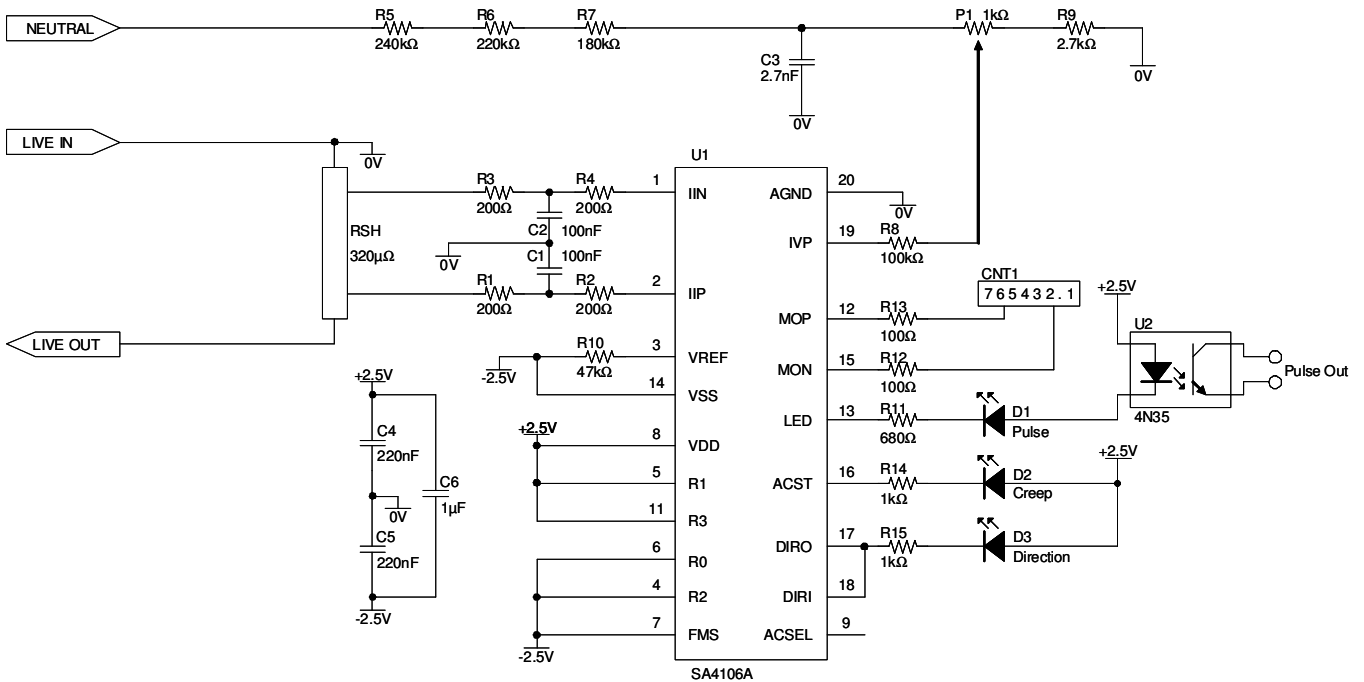

Figure 11: Typical application circuit

Table 6: Component list for typical application

Symbol	Description
U1	Energy metering device, SA4106ASAR
U2	Opto-coupler, 1N35
RSH	Shunt Resistor, 40A, 320μΩ
R1, R2 ¹ , R3, R4 ¹	Resistor, 200Ω, 1%, metal film
R5	Resistor, 240kΩ, 1%, metal film
R6	Resistor, 220kΩ, 1%, metal film
R7	Resistor, 180kΩ, 1%, metal film
R8 ¹	Resistor, 100kΩ, 1%, metal film
R9	Resistor, 2.7kΩ, 1%, metal film
R10 ¹	Resistor, 47kΩ, 1%, metal film
R11	Resistor, 680Ω, 5%, carbon film
R12, R13	Resistor, 100Ω, 5%, carbon film

Symbol	Description
R14, R15	Resistor, 1kΩ, 5%, carbon film
P1	Trim-pot, 25 turns, 1kΩ
C1, C2	Capacitor, 100nF, ceramic
C3	Capacitor, 2.7nF, ceramic
C4 ² , C5 ²	Capacitor, 220nF, ceramic
C6 ²	Capacitor, 1μF, ceramic
D1	Light emitting diode, pulse output
D2	Light emitting diode, anti-creep state output
D3	Light emitting diode, energy direction output
CNT1	Stepper motor counter, 100imp/kWh

Note 1: Resistors R2, R4, R8 and R10 must be positioned as close as possible to the respective device pins

Note 2: Capacitors C4, C5 and C6 must be positioned as close as possible to the V_{DD} and V_{SS} power supply pins



PACKAGE DIMENSIONS

SOIC20 Package

Dimensions are shown in inches

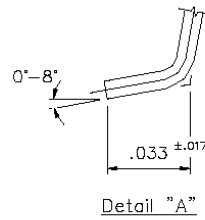
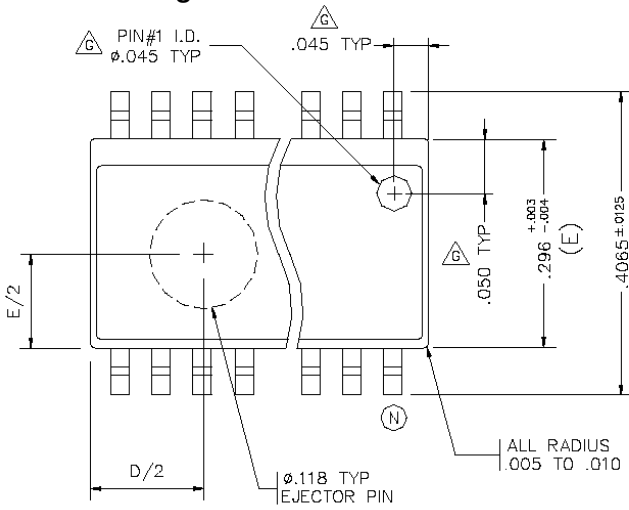

N	D VARIATIONS		
	MIN	NOM	MAX
16	.398	.405	.412
18	.449	.456	.463
20	.496	.503	.510
24	.599	.606	.613
28	.697	.704	.711

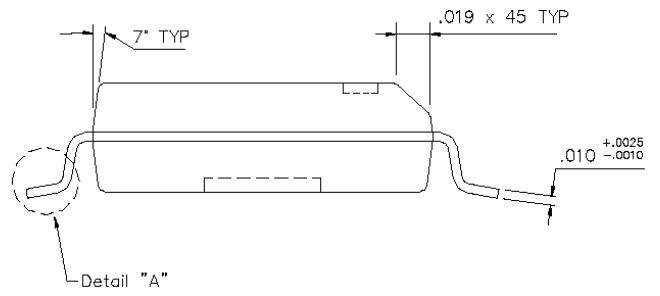
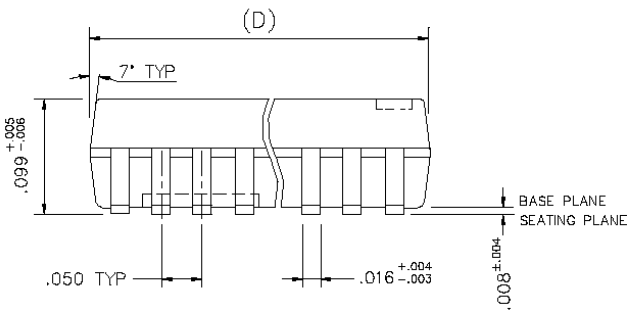



NOTES

**DISCLAIMER**

The information contained in this document is confidential and proprietary to Integrated Circuit Design Centre (Pty) Ltd ("ICDC"), a division of South African Micro-electronic Systems (Pty) Ltd ("SAMES"), and may not be copied or disclosed to a third party, in whole or in part, without the express written consent of ICDC. The information contained herein is current as of the date of publication; however, delivery of this document shall not under any circumstances create any implication that the information contained herein is correct as of any time subsequent to such date. ICDC does not undertake to inform any recipient of this document of any changes in the information contained herein, and ICDC expressly reserves the right to make changes in such information, without notification, even if such changes would render information contained herein inaccurate or incomplete. ICDC makes no representation or warranty that any circuit designed by reference to the information contained herein, will function without errors and as intended by the designer.

Any sales or technical questions may be posted to our e-mail address below:
support@sames.co.za

For the latest updates on datasheets, please visit our web site:
<http://www.sames.co.za>

INTEGRATED CIRCUIT DESIGN CENTRE (PTY) LTD
a division of
SOUTH AFRICAN MICRO-ELECTRONIC SYSTEMS (PTY) LTD

Tel: (012) 333-6021
Tel: Int +27 12 333-6021
Fax: (012) 333-6393
Fax: Int +27 12 333-6393

P O BOX 15888
LYNN EAST 0039
REPUBLIC OF SOUTH AFRICA

33 ELAND STREET
KOEDOESPOORT INDUSTRIAL AREA
PRETORIA
REPUBLIC OF SOUTH AFRICA