

# Single Phase Kilowatt-hour Metering IC

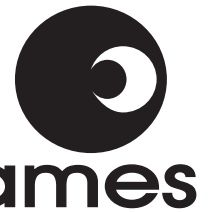

## SA2102D

### FEATURES

- Meets the IEC 61036 Specification requirements for Class 1 AC static watt-hour meters for active energy
- Less than 0.5% Error over a dynamic range of 1:1000
- The motor drive outputs (MOP, MON) provide the average power information and can drive an electro-mechanical counter directly
- LED pulse output for calibration purposes
- Bi-directional and uni-directional energy measurement
- Configurable for different meter ratings
- Precision on-chip oscillator (70ppm/°C drift)
- Precision on-chip voltage reference (10ppm/°C drift)
- On-chip anti-creep function (0.02% of I<sub>max</sub>)
- Low power consumption (<25mW typical)

### DESCRIPTION

The SAMES SA2102D\* is an accurate single phase power/energy metering integrated circuit providing a single-chip solution for energy meters. Very few external components are required and has direct drive capability for electro mechanical counters. The SA2102D does not require an external crystal. A precision oscillator, which supplies the circuitry with a stable frequency, is integrated on chip. The SA2102D metering integrated circuit generates a pulse rate output, the frequency of which is proportional to the power consumption. The SA2102D performs the calculation for active power. The method of calculation takes the power factor into account.

(I<sub>MAX</sub>) and nominal voltages (V<sub>NOM</sub>) without having to change the stepper motor or impulse counter gear ratio. The LED pulse output follows the average power consumption measured and is intended for meter calibration purposes. In fast calibration mode this output provides a high frequency pulse rate following the instantaneous power consumption and can be used for fast calibration or to interface with a microcontroller. The SA2102D includes an anti-creep feature preventing any creep effects in the meter. The SA2102D can be configured for positive, negative or bi-directional energy measurement.

Programmable inputs allow the meter manufacturer to configure the SA2102D for different meter maximum currents

The SA2102D integrated circuit is pin compatible to the SA2002D and is available in 20 pin dual-in-line plastic (PDIP20), as well as 20 pin small outline (SOIC20) package types.

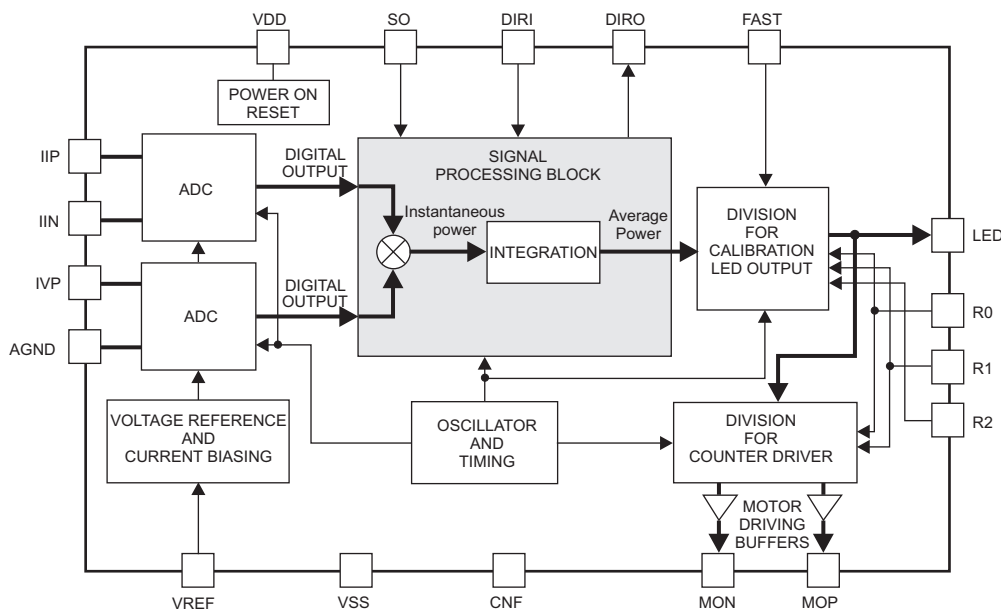

Figure 1: Block diagram

\* Patents EP0559499, US5396447, PT559499T, ZA9301579, ZA9400273, ZA9702075

<http://www.sames.co.za>

**ELECTRICAL CHARACTERISTICS**

( $V_{DD} = 2.5V$ ,  $V_{SS} = -2.5V$ , over the temperature range  $-10^{\circ}C$  to  $+85^{\circ}C^{\#}$ , unless otherwise specified. Refer to Figure 2 Test Circuit for Electrical Characteristics.)

Parameter	Symbol	Min	Typ	Max	Unit	Condition
<b>General</b>						
Supply Voltage: Positive	$V_{DD}$	2.25		2.75	V	
Supply Voltage: Negative	$V_{SS}$	-2.75		-2.25	V	
Supply Current: Positive	$I_{DD}$	2.5	3.6	5	mA	
Supply Current: Negative	$I_{SS}$	2.5	3.6	5	mA	
<b>Inputs</b>						
<b>Current Sensor Inputs (Differential)</b>						
Input Current Range	IIP, IIN	-25		+25	$\mu A$	Peak value
IIP, IIN Offset Voltage	IIP, IIN	-3.1		+3.1	mV	
<b>Voltage Sensor Input (Asymmetrical)</b>						
Input Current Range	IVP	-25		+25	$\mu A$	Peak value
Offset Voltage	IVP	-2.5		+2.5	mV	
<b>Digital Inputs</b>						
DIRI Input leakage	DIRI			0.95	$\mu A$	
Pull down Current R2, R1, R0, FAST, CNF, SO	IPD	80		140	$\mu A$	
R2, R1, R), FAST, CNF, SO Input High Voltage	$V_{IH}$	$V_{DD}-1$			V	
Input Low Voltage	$V_{IL}$			$V_{SS}+1$	V	
<b>Outputs</b>						
<b>Digital Outputs</b>						
LED, DIRO Output High Voltage	$V_{OH}$	$V_{DD}-1$			V	$I_{SOURCE} = 5mA$
Output Low Voltage	$V_{OL}$			$V_{SS}+1$	V	$I_{SINK} = 5mA$
MON, MOP Output High Voltage	$V_{OH}$		4.4		V	$I_{SOURCE} = 15mA$
Output Low Voltage	$V_{OL}$		0.1		V	$I_{SINK} = 15mA$

# Extended Operating Temperature Range available on request.

During manufacturing, testing and shipment we take great care to protect our products against potential external environmental damage such as Electrostatic Discharge (ESD). Although our products have ESD protection circuitry, permanent damage may occur on products subjected to high-energy electrostatic discharges accumulated on the human body and test equipment and can discharge without detection. Therefore, proper ESD precautions are recommended to avoid performance degradation or loss of functionality during product handling.

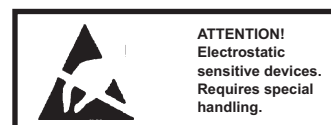



### ELECTRICAL CHARACTERISTICS (continued)

(V<sub>DD</sub> = 2.5V, V<sub>SS</sub> = -2.5V, over the temperature range -10°C to +85°C<sup>#</sup>, unless otherwise specified. Refer to Figure 2 Test Circuit for Electrical Characteristics.)

Parameter	Symbol	Min	Typ	Max	Unit	Condition
<b>Reference Voltage Input VREF</b>						
Ref. Current	-I <sub>R</sub>	23	25	27	μA	
Ref. Voltage	V <sub>R</sub>	1.1		1.3	V	With R = 47KΩ connected to V <sub>SS</sub>
Temperature coefficient			10		ppm/°C	
<b>On-chip oscillator</b>						
Oscillator frequency			3.73723		MHz	
Temperature coefficient			70		ppm/°C	

# Extended Operating Temperature Range available on request.

### ABSOLUTE MAXIMUM RATINGS\*

Parameter	Symbol	Min	Max	Unit
Supply Voltage	V <sub>DD</sub> -V <sub>SS</sub>	3.6	6	V
Operating temperature limits	T <sub>limit</sub>	-40	+85	°C
Storage Temperature	T <sub>STG</sub>	-40	+125	°C
Specified operating range	T <sub>O</sub>	-25	+85	°C

\*Stresses above those listed under “Absolute Maximum Ratings” may cause permanent damage to the device. This is a stress rating only. Functional operation of the device at these or any other condition above those indicated in the operational sections of this specification, is not implied. Exposure to Absolute Maximum Ratings for extended periods may affect device reliability.

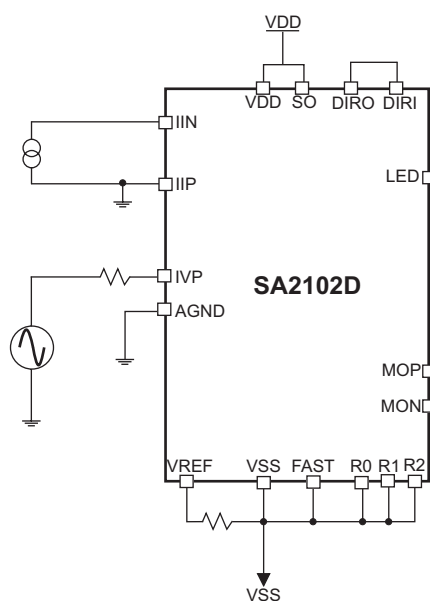

Figure 2: Test Circuit for Electrical Characteristics

**PIN DESCRIPTION**

PIN	Designation	Description
20	AGND	Analog Ground. The supply voltage to this pin should be mid-way between VDD and Vss.
8	VDD	Positive Supply Voltage. The voltage to this pin is typically +2.5V if a shunt resistor is used for current sensing or in the case of a current transformer a +5V supply can be applied.
14	Vss	Negative Supply Voltage. The voltage to this pin is typically -2.5V if a shunt resistor is used for current sensing or in the case of a current transformer a 0V supply can be applied.
19	IVP	Analog Input for Voltage. The current into the voltage sense input IVP should be set at $14\mu A_{RMS}$ at Nominal Mains Voltage ( $V_{NOM}$ ). The voltage sense input saturates at an input current of $\pm 25\mu A$ peak.
1,2	IIN, IIP	Analog input for current. The current into the current sense input IIP pin should be set at $16\mu A_{RMS}$ at Maximum Rated Mains Current ( $I_{MAX}$ ). The current sense input saturates at $\pm 25\mu A$ peak.
3	VREF	This pin provides the connection for the reference current setting resistor. A $47k\Omega$ resistor connected to Vss sets the optimum operating condition.
6, 5, 4	R0, R1, R2	Rated Condition Select. These inputs are used for the different rated condition configuration. Refer to the Rated Condition Select section.
7	FAST	This input is used to select between STANDARD and FAST mode (LED output pulse rate). Refer to the LED output section.
11	SO	Select Output. When fast mode is selected this input can be used to enable or disable the internal pulse stability circuitry for the LED output pulses. Refer to the Select Output section.
18	DIRI	Direction select input. This input is used to enable either bi-directional or uni-directional energy measurement.
17	DIRO	Direction indicator output. This output indicates the energy flow direction.
13	LED	Calibration LED output. Refer to the Rated Condition Select section of the pulse rate output options
12, 15	MOP, MON	Motor pulse outputs. These outputs can drive an electromechanical counter directly.
9	CNF	Configure / Test input. For normal operation this pin must be connected to Vss.
10, 16	NC	No Connection.

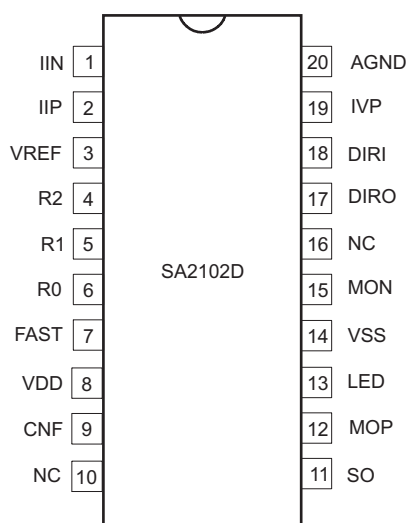

Figure 3: Pin connections: Package: PDIP20, SOIC20



## TERMINOLOGY

### Bi-directional and Uni-directional measurement

In the bi-directional configuration the LED, MON and MOP outputs generate pulses at a frequency that is proportional to the energy measured in both forward and reverse directions.

In the uni-directional configuration the LED, MOP and MON outputs generate pulses at a frequency that is proportional to the energy measured only if the energy flow is in the same direction as selected by the DIRI pin. No output pulses are generated for energy flowing counter to the DIRI pin selection. The DIRI pin can select either positive or negative energy flow.

### Positive energy

Positive energy is defined when the phase difference between the input signals IIP and IVP are less than 90 Degrees.

### Negative energy

Negative energy is defined when the phase difference between the input signals IIP and IVP is greater than 90 degrees (90..270 degrees).

### Percentage error\*

Percentage error is given by the following formula:

$$\%Error = \frac{\text{Energy registered by SA2102D} - \text{True energy}}{\text{True energy}} \times 100$$

NOTE Since the true value cannot be determined, it is approximated by a value with a stated uncertainty that can be traced to standards agreed upon between manufacturer and user or to national standards.

### Rated Operating Conditions\*

Set of specified measuring ranges for performance characteristics and specified operating ranges for influence quantities, within which the variations or operating errors of a meter are specified and determined.

### Specified Measuring Range\*

Set of values of a measured quantity for which the error of a meter is intended to lie within specified limits.

### Specified Operating Range\*

Range of values of a single influence quantity, which forms a part of the rated operating conditions.

### Limit range of operation\*

Extreme conditions which an operating meter can withstand without damage and without degradation of its metrological characteristics when it is subsequently operated under its rated operating conditions.

### Nominal Mains Voltage (V<sub>NOM</sub>)

Nominal Mains Voltage (V<sub>NOM</sub>) is the voltage specified for the energy meter at Rated Operating Conditions.

### Maximum Rated Mains Current (I<sub>MAX</sub>)

Maximum Rated Mains Current is the current flowing through the energy meter at Rated Operating Conditions.

### Constant\*

Value expressing the relation between the active energy registered by the meter and the corresponding value of the test output. If this value is a number of pulses, the constant should be either pulses per kilowatt-hour (imp/kWh) or watt-hours per pulse (Wh/imp).

\*IEC 61036, 2000. Alternating Current Static Watt-hour Meters for Active Energy. Edition 2.1



PERFORMANCE GRAPHS

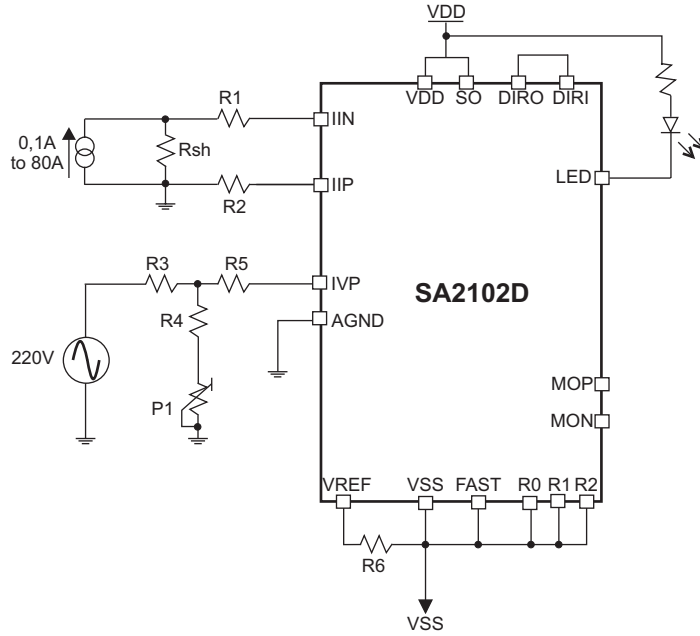
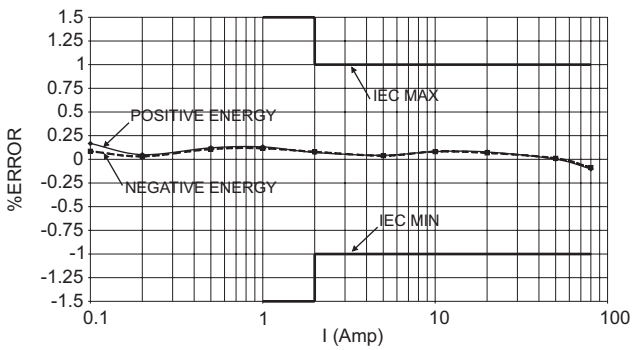
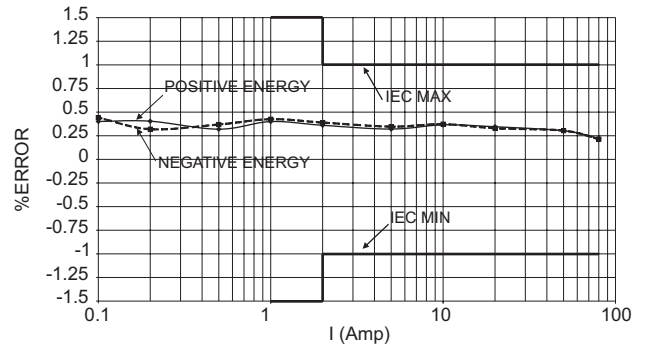

Figure 4: Test circuit for performance graphs



GRAPH 1 - Linearity PF=1, FREQ=50Hz, Vnom, TEMP=25°C



GRAPH 2 - Linearity PF=+0.5, FREQ=50Hz, Vnom, TEMP=25°C

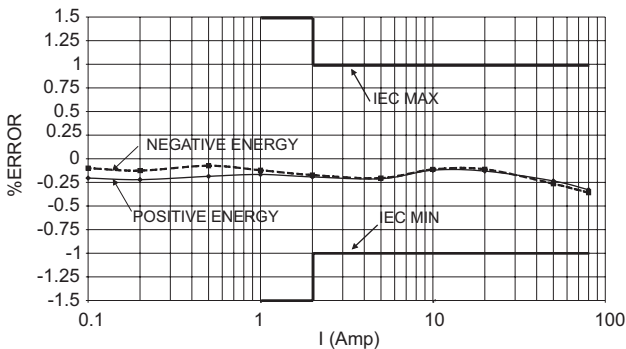

GRAPH 3 - Linearity PF=-0.5, FREQ=50Hz, Vnom, TEMP=25°C

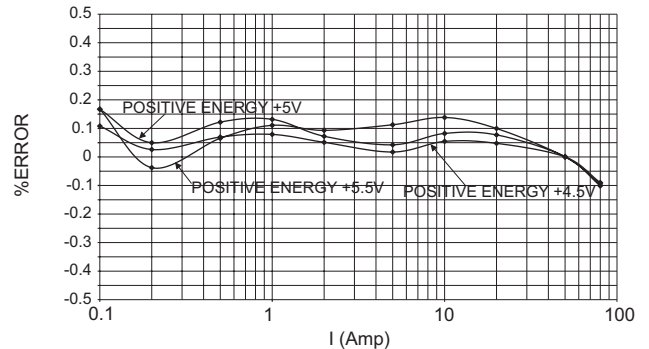

GRAPH 4 - Linearity PF=1, Supply=+5.5V, +5V, +4.5V



**FUNCTIONAL DESCRIPTION**

The SA2102D is a CMOS integrated circuit, which performs power/energy calculations across a dynamic range of 1000:1 to an accuracy that exceeds the IEC 61036 Class 1 specification.

The integrated circuit includes all the required functions for single phase power and energy measurement. Two A/D converters sample the voltage and current inputs. The calculations required for power and energy are performed and pulses on the LED, MON and MOP outputs represent the results.

Internal offsets are eliminated through the use of cancellation techniques. The SA2102D generates pulses at a frequency that is proportional to the power consumption. Complimentary output pins MOP and MON are provided for driving a stepper motor. A MOP pulse followed immediately by a MON pulse represents an energy pulse. This minimizes the risk of (after power up) losing the first energy pulse as a result of the stepper motor residing in the wrong phase.

The LED output is normally proportional to the average power consumption measured. When in FAST mode, the LED output is proportional to the instantaneous active power consumption. The FAST mode is intended for meter calibration purposes.

The two A/D converters convert the signals on the voltage and current sense inputs to a digital format for further processing. The current sense inputs (IIP and IIN) are identical and balanced. A input signal with a range of 1:1000 is measured at these inputs.

An integrated anti-creep function prevents any output pulses if the measured power is less than 0.02% of the meters rated current.

The two digital signals, accurately representing the current and voltage inputs, are multiplied using digital multiplication. The output of the multiplier is the instantaneous power.

For voltage and current in phase instantaneous power is calculated by:

$$\begin{aligned} \text{Instantaneous power } p(t) &= v(t) \times i(t) \\ &= V_M \sin(\omega t + \theta) \times I_M \sin(\omega t + \psi) \end{aligned}$$

$$\text{let } \phi = \theta - \psi, V_{RMS} = \frac{V_M}{\sqrt{2}}, I_{RMS} = \frac{I_M}{\sqrt{2}}$$

$$\begin{aligned} p(t) &= V_M I_M \sin(\omega t + \theta) \sin(\omega t + \psi) \\ &= V_M I_M \sin(\omega t + \theta) \sin(\omega t + \theta - \phi) \\ &= V_{RMS} I_{RMS} [\cos \phi - \cos(2(\omega t + \theta) - \phi)] \end{aligned}$$

where  $v(t)$  is the instantaneous voltage  
 $i(t)$  is the instantaneous current,  
 $V_M$  is the maximum amplitude of the voltage signal,  
 $I_M$  is the maximum amplitude of the current signal,  
 $\theta$  is the voltage phase angle,  
 $\psi$  is the current phase angle and  
 $V I \cos(2(\omega t + \theta) - \phi) = 100\text{Hz noise component on a } 50\text{Hz mains system.}$

This power information is then integrated over time to provide the average power information.

$$\begin{aligned} \text{Average Power (P)} &= \frac{1}{T} \int_0^T p(t) dt \\ &= V_{RMS} I_{RMS} \cos \phi \end{aligned}$$

Where  $p(t)$  is the instantaneous power and  $\cos \phi$  is the power factor.

**ANALOG INPUT CONFIGURATION**

The input circuitry of the current and voltage sensor inputs is illustrated in figure 5.

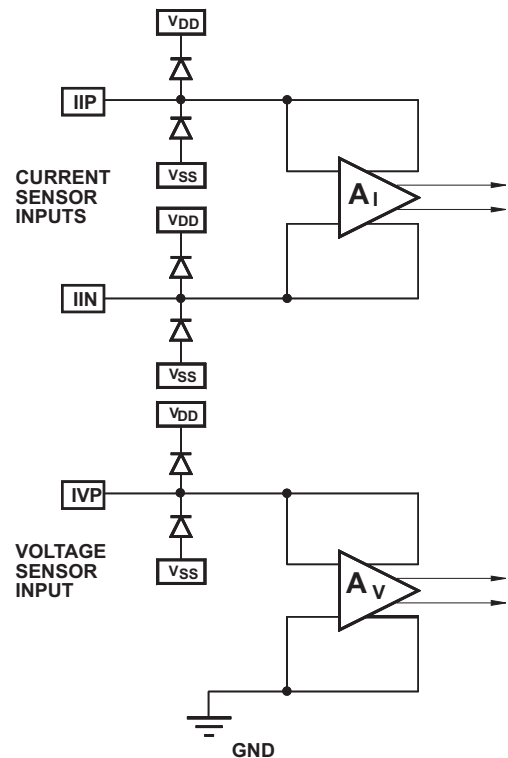

DR-01148

Figure 5: Analog input configuration

## SA2102D

These inputs are protected against electrostatic discharge through clamping diodes.

The feedback loops from the outputs of the amplifiers  $A_I$  and  $A_V$  generate virtual shorts on the signal inputs. Exact duplications of the input currents are generated for the analog signal processing circuitry.

The current and voltage sense inputs are both identical. Both inputs are differential current driven up to  $\pm 25\mu\text{A}$  peak. One input of the voltage sense amplifier is internally connected to AGND. This is possible because the voltage sense input is much less sensitive to externally induced parasitic signals compared to the current sense inputs.

### POWER CONSUMPTION

The power consumption of the SA2102D integrated circuit is less than 25mW.

### INPUT SIGNALS

#### Voltage Reference (VREF)

A bias resistor of  $47\text{k}\Omega$  sets optimum bias and reference conditions on chip. Calibration of the SA2102D should be done on the voltage input as described in the Typical Application section and not on the Vref input.

#### Current sense input (IIP and IIN)

Figure 6 shows the typical connections for the current sensor input. The resistor R1 and R2 define the current level into the current sense inputs of the SA2102D. At Maximum Rated Mains current ( $I_{MAX}$ ) the resistor values should be selected for an input current of  $16\mu\text{A}_{RMS}$ .

The values for resistors R1 and R2 can be calculated as follows:

$$R1 = R2 = (I_L / 16\mu\text{A}) \times RSH / 2$$

Where  $I_L$  = Line current

$RSH$  = Shunt resistor or termination resistor if a CT is used as the current sensor.

The value of  $RSH$ , if used as the CT's termination resistor, should be less than the DC resistance of the CT's secondary winding. The voltage drop across  $RSH$  should not be less than  $20\text{mV}_{RMS}$  at  $I_{M \times}$

#### Voltage Sense Input (IVP)

The current into the A/D converter should be set at  $14\mu\text{A}_{RMS}$  at Nominal Mains Voltage ( $V_{NOM}$ ). This is to allow a variation of  $\pm 10\%$  for the mains voltage without saturating the voltage sense input. The voltage sense input saturates at an input current of  $\pm 25\mu\text{A}$  peak. Referring to Figure 6 the typical connections for the voltage sense input is illustrated. Resistors R3, R4 and R5 set the current for the voltage sense input. The Nominal Mains Voltage is divided down to  $14V_{RMS}$ . The current into the A/D converter input is set at  $14\mu\text{A}_{RMS}$  via resistor R5 of value  $1\text{M}\Omega$ .

#### Fast Mode Select (FAST)

The FAST pin is used to select between STANDARD and FAST mode. Leaving this pin open or connecting to  $V_{SS}$  enables the STANDARD mode and connecting to  $V_{DD}$  enables FAST mode.

When STANDARD mode is enabled the LED output pulses at a low frequency. This low frequency allows a longer accumulation period and the output pulses are therefore proportional to the average power consumption measured.

The Rated Select Condition pins (R0, R1 and R2) are used to select different LED output frequencies which in turn selects the applications meter constant. Refer to figure 8 for the LED output timing diagram in STANDARD mode.

When the FAST mode is enabled the LED output generates pulses at a frequency of 1160Hz at  $I_{MAX}$  and  $V_{NOM}$ . In this mode the pulse frequency is proportional to the instantaneous power consumption measured. This mode is used for meter calibration purposes and can also be used when interfacing to a microcontroller. Refer to figure 9 for the LED output timing diagram in FAST mode.

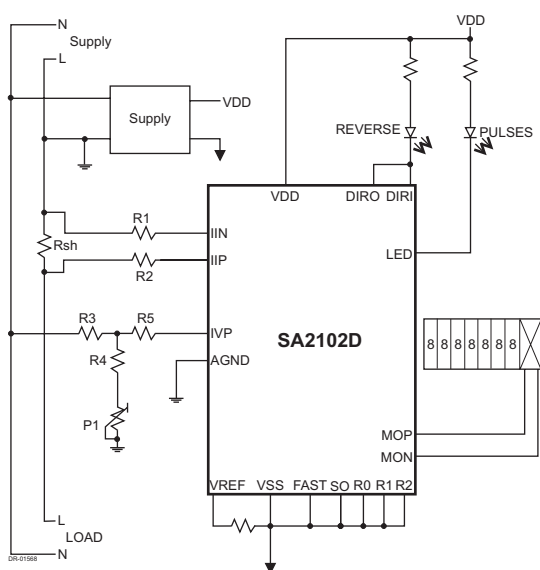

Figure 6: Application circuit

**Select Output (SO)**

The SA2102D has unique internal circuitry that can be user enabled to stabilize the LED output. When in FAST mode, connecting the SO input pin to Vdd will enable the LED pulse stability feature. Stabilizing the LED pulse output allows for shorter meter calibration times. Leaving the SO pin open or connecting to Vss will disable the LED pulse stability circuitry. Figure 9 indicates the operation of pulse stability.

**Rated Condition Select (R0, R1, R2)**

The Rated Condition Select pins R0, R1 and R2 are inputs pins used to configure the SA2102D for different Maximum Rated Mains Currents and Nominal Mains Voltages. This feature allows for the use of different stepper motor gear ratios.

To calculate the LED output pulse rate (in STANDARD mode) and motor drive pulse rate for any meter ratings ( $I_{MAX}$  and  $V_{NOM}$ ) the following formulae can be used:

$$\text{LED pulses / kWh} = 1160 \times (1/DF\_LED) \times \frac{3600}{(V_{NOM} \times I_{MAX}) / 1000}$$

Where: ..... ①

$I_{MAX}$  = Maximum Rated Mains current

$V_{NOM}$  = Nominal Mains Voltage

DF\_LED is the dividing factor and depends on R2, R1 and R0:

R2	R1	R0	DF_LED
0	0	0	322
0	0	1	322
0	1	0	322
0	1	1	322
1	0	0	536
1	0	1	214
1	1	0	214

Table 1: LED Output Constants

$$\text{Motor pulses / kWh} = \text{LED pulses/kWh} / DF\_MO$$

Where: ..... ②

LED pulses / kWh as calculated in formula 1

DF\_MO is the dividing factor and depends on R1 and R0:

R1	R0	DF_MO
0	0	64
0	1	32
1	0	16
1	1	8

Table 2: MOTOR Output Constants

Table 3 shows some of the meter constants available for several maximum currents ( $I_{MAX}$ ) and with a line voltage of 220V while in STANDARD mode.

Note that the values calculated using formulae 1 and 2 are close approximations to the values listed in table 3. The SA2102D has to be calibrated (using the voltage input) to give the exact value listed.

R2	R1	R0	Vnom / Imax	LED Output (Pulses/kWh)	MOP and MON Outputs (Pulses/kWh)
0	0	0	220V/10A	6400	100
0	0	1	220V/20A	3200	100
0	1	0	220V/40A	1600	100
0	1	1	220V/80A	800	100
1	0	0	220V/6A	6400	100
1	0	1	220V/30A	3200	100
1	1	0	220V/60A	1600	100

Table 3: Some meter constants available for several maximum currents ( $I_{MAX}$ ) and with a line voltage of 220V, while in STANDARD mode.

**Direction Select Input (DIRI)**

Depending on the state of the DIRI pin the energy to be measured can be in the positive direction only, or in the negative direction only, or in both directions.

Connecting DIRI to VDD will result in energy only being measured in the positive direction. Energy flowing in the negative direction will not be measured. Connecting DIRI to VSS will result in energy only being measured in the negative direction. Energy flowing in the positive direction will not be measured. Connecting the DIRI pin to the DIRO output pin enables the bi-direction mode where energy is measured regardless of direction.



**OUTPUT SIGNALS**

**Motor pulse output (MOP, MON)**

The MOP and MON pins are complimentary outputs with a frequency proportional to the average power consumption measured. These outputs can be used to either directly drive a stepper motor counter or an electro mechanical impulse counter. The Rated Conditions Select pins (R0, R1, R2) allows the selection of different output frequencies corresponding to different Meter Constants. Figure 7 indicates the timing of these signals.

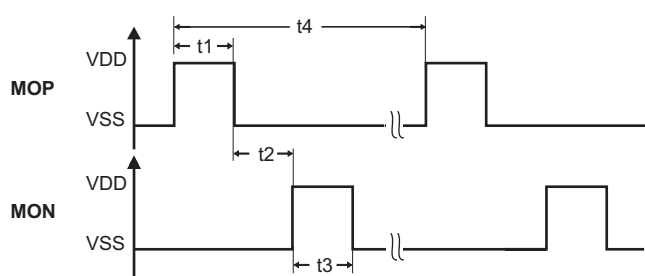

t1 = t2 = t3 = 213ms

t4 is proportional to the average power and can be calculated using Equation 2 and the Motor Output Constants in Table 2.

Figure 7: Motor output MON and MOP

**LED Output (LED)**

The LED output pin provides a pulse output with a frequency proportional to the average energy when in STANDARD mode and the instantaneous energy when in FAST mode. This output is primarily used for calibration purposes. The Rated Conditions Select pins (R0, R1, R2) allow different frequencies to be selected. The LED output is active low. Figure 8 shows the LED waveform when in STANDARD mode.

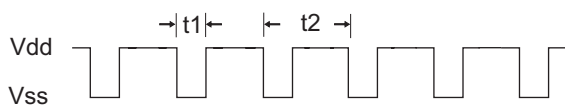

t1 = 90ms

t2 is proportional to the average power and can be calculated using Equation 1 along with the appropriate LED Output Constant in Table 1.

Figure 8: LED pulse output in STANDARD mode

In FAST mode the LED pulse output is set at a high frequency of 1160Hz at I<sub>MAX</sub> and V<sub>NOM</sub>. This mode is useful for fast calibration and can be used to interface to a micro-controller. Figure 9 indicates the LED output signal in FAST mode.

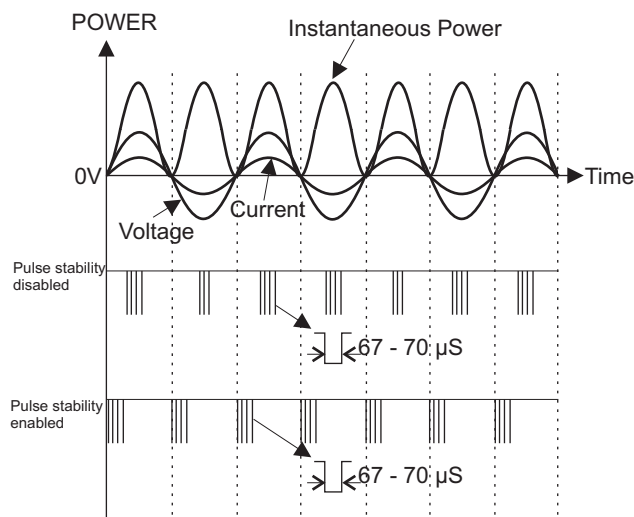

Figure 9: LED pulse output in fast mode

To convert pulses per kilowatt-hour to frequency (in Hz ) or vice versa the following equations can be used:

$$\text{Frequency (pulses per second)} = \text{P/kWh} \left/ \left[ \frac{3600}{(I \times V)} \right] \right.$$

$$\text{P/kWh} = \text{frequency} \times \left[ \frac{3600}{(I \times V)} \right]$$

where:

P/kWh = LED or MON/MOP pulse constant

I = current in amperes

V = voltage (normally V<sub>NOM</sub>)

**Direction Indicator Output (DIRO)**

The direction energy flow may be ascertained by monitoring the DIRO pin. A logic 0 on this pin indicates negative energy flow. Positive energy flow, is indicated on pin DIRO as a logic 1. The DIRO pin may be used to drive a LED.

**TYPICAL APPLICATION**

In figure 10, the components required for a stand alone power metering application, are shown. The application uses a shunt resistor for the mains current sensing. The meter is designed for 220V/40A operation.

The critical external components for the SA2102D integrated circuit are the current sense resistors, the voltage sense resistors as well as the bias setting resistor.

**BIAS RESISTOR**

R13 defines all on-chip and reference currents. With R13=47kΩ, optimum conditions are set. Device calibration is done on the voltage input of the device.

**SHUNT RESISTOR**

The voltage drop across the shunt resistor at rated current should be at least 20mV. If a shunt resistor of 625μΩ is chosen and a voltage of 25mV across the shunt is required at I<sub>MAX</sub> then the power dissipation in the current sensor is:

$$\begin{aligned}
 P &= I^2R \\
 &= (40A)^2 \times 625\mu\Omega \\
 &= 1W.
 \end{aligned}$$

**CURRENT SENSE RESISTORS**

The resistors R6 and R7 define the current level into the current sense inputs of the device. The resistor values are selected for an input current of 16μA on the current inputs of the SA2102D at I<sub>MAX</sub>.

According to equation described in the Current Sense inputs section:

$$\begin{aligned}
 R6 = R7 &= (IL / 16\mu A) \times RSH/2 \\
 &= 40A / 16\mu A \times 625\mu/2 \\
 &= 781.25\Omega
 \end{aligned}$$

A resistor with value of 820Ω is chosen, the 5% deviation from the calculated value will be compensated for when calculating resistor values for the voltage path.

**VOLTAGE DIVIDER**

The voltage divider is calculated for a voltage drop of 14V + 5%(14.7V). Equations for the voltage divider in figure 10 are: R1 + R2 + R3 = RA and R12 || (R11+P1) = RB. Combining the two equations gives:

$$(RA + RB) / 220V = RB / 14.7V$$

A 5k trimpot will be used in the voltage channel for meter calibration. The center position on the pot is used in the calculations. P1 = 2.5kΩ and values for resistors R11 = 22kΩ and R12 = 1MΩ are chosen.

Substituting the values will result in:

RB=23.91kΩ and RA=RB x (220V/14.7V - 1) resulting in RA=333kΩ so the resistor values of R1, R2 and R3 are chosen to be 110kΩ.

**PROGRAMMING**

The resistor values are calculated for a 40A rated meter. The LED pulse rate must be set accordingly by programming pins R0, R1 and R2. Using the Rated Conditions Select section, pins R0 and R2 is set to VSS and R1 set to VDD. These settings will configure the SA2102D for 220V/40A operation with a LED pulse rate of 1600 pulses/kWh. The FAST pin is set to VSS for STANDARD operation.

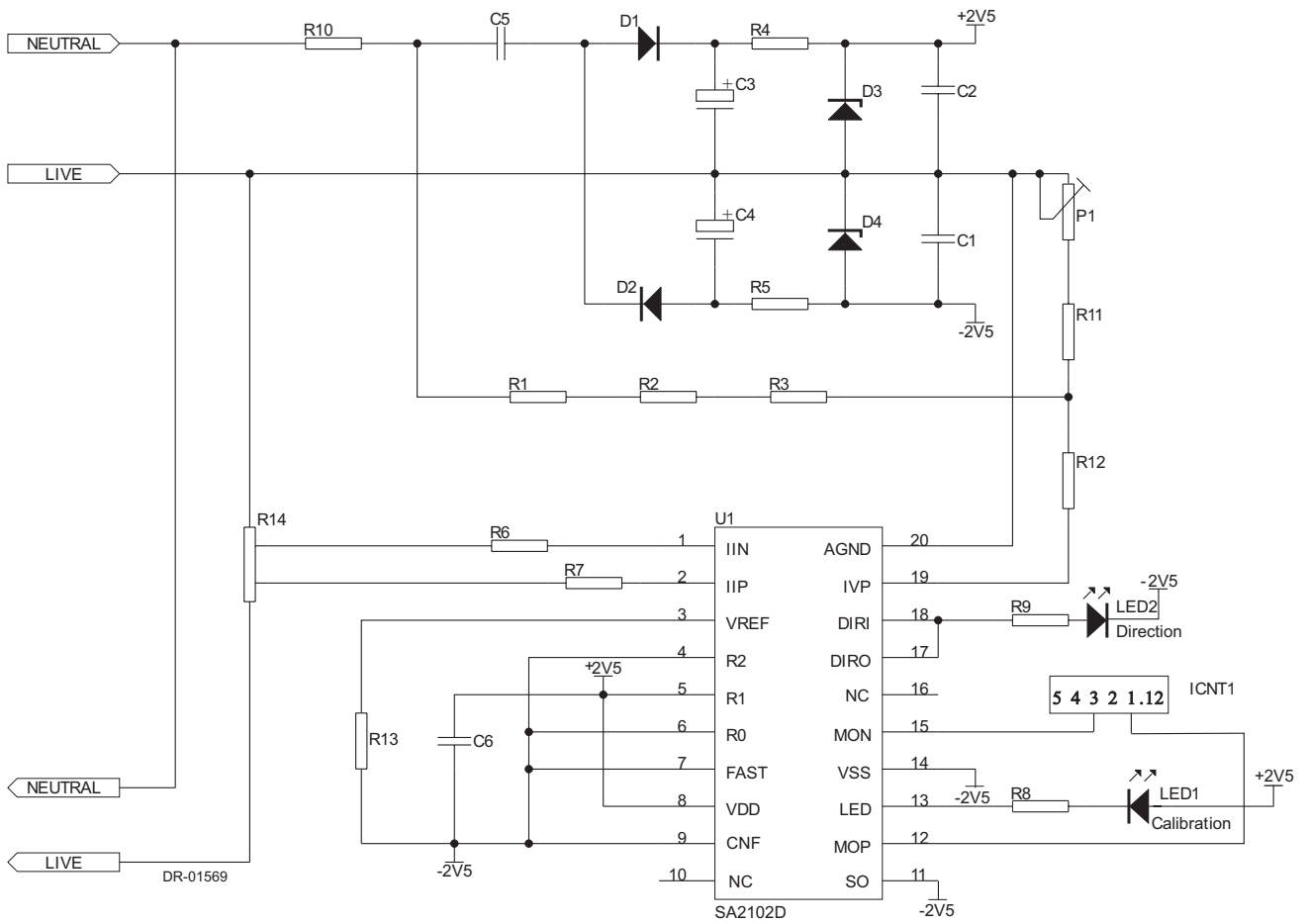

220V/40A meter with 1600 pulses/kWh resolution

Figure 10: Application circuit

**Parts List for Application Circuit: Figure 10**

Symbol	Description	Detail
U1	SA2102D	PDIP20/SOIC20
D1	Diode, Silicon, 1N4002	
D2	Diode, Silicon, 1N4002	
D3	Diode, Zener, 2.4V	
D4	Diode, Zener, 2.4V	
R1	Resistor, 110k, 1/4W, 1%, metal	
R2	Resistor, 110k, 1/4W, 1%, metal	
R3	Resistor, 110k, 1/4W, 1%, metal	
R4	Resistor, 680, 1/4W, 1%, metal	
R5	Resistor, 680, 1/4W, 1%, metal	
R6	Resistor, 820, 1/4W, 1%, metal	Note 1
R7	Resistor, 820, 1/4W, 1%, metal	Note 1
R8	Resistor, 2K, 1/4W	
R9	Resistor, 2K, 1/4W	
R10	Resistor, 47R, 2W, 5%, wire wound	
R11	Resistor, 22k 1/4W, 1%, metal	
R12	Resistor, 1M, 1/4W, 1%, metal	
R13	Resistor, 47k, 1/4W, 1%, metal	
R14	Shunt resistor 625 $\mu\Omega$	Note 1
P1	Trim pot, 5k, Multi turn	
C1	Capacitor, 220nF, Ceramic	
C2	Capacitor, 220nF, Ceramic	
C3	Capacitor, 100uF, 16V, electrolytic	
C4	Capacitor, 100uF, 16V, electrolytic	
C5	Capacitor, 330nF, 250VAC	
C6	Capacitor, 820nF, Ceramic	Note 2
LED1	3mm Light emitting diode	
LED2	3mm Light emitting diode	
ICNT1	Stepper Motor	

Note 1: Resistor (R6 and R7) values are dependant on the selected shunt resistor (R14) value.

Note 2: Capacitor C6 to be positioned as close as possible to supply pins.

**ORDERING INFORMATION**

Part Number	Package
SA2102DPA	PDIP20
SA2102DSA	SOIC20





**NOTES:**

**DISCLAIMER:**

The information contained in this document is confidential and proprietary to South African Micro-Electronic Systems (Pty) Ltd ("SAMES") and may not be copied or disclosed to a third party, in whole or in part, without the express written consent of SAMES. The information contained herein is current as of the date of publication; however, delivery of this document shall not under any circumstances create any implication that the information contained herein is correct as of any time subsequent to such date. SAMES does not undertake to inform any recipient of this document of any changes in the information contained herein, and SAMES expressly reserves the right to make changes in such information, without notification, even if such changes would render information contained herein inaccurate or incomplete. SAMES makes no representation or warranty that any circuit designed by reference to the information contained herein, will function without errors and as intended by the designer.

Any sales or technical questions may be posted to our e-mail address below:  
**[energy@sames.co.za](mailto:energy@sames.co.za)**

For the latest updates on datasheets, please visit our web site:  
**<http://www.sames.co.za>**

**SOUTH AFRICAN MICRO-ELECTRONIC  
SYSTEMS (PTY) LTD**

**Tel:** (012) 333-6021  
**Tel: Int** +27 12 333-6021  
**Fax:** (012) 333-8071  
**Fax: Int** +27 12 333-8071

**P O BOX 15888  
LYNN EAST  
0039  
REPUBLIC OF SOUTH AFRICA**

**33 ELAND STREET  
KOEDOESPOORT INDUSTRIAL AREA  
PRETORIA  
REPUBLIC OF SOUTH AFRICA**