

Single Phase Power/Energy Metering IC with Tamper Detection



sames

SA2007M

FEATURES

- Provides direct interface to mechanical counters
- Monitors Live and Neutral for tamper detection
- Performs bidirectional energy measurement
- Various setup modes selectable
- Meets the IEC 521/1036 Specification for Class 1 AC Watt hour meters

- Total power consumption rating below 40mW
- Adaptable to different types of sensors
- Operates over a wide temperature range
- Precision voltage reference on-chip
- Precision oscillator on chip

DESCRIPTION

The SAMES SA2007M is a single-phase bidirectional energy metering integrated circuit. It provides a mono-chip solution for energy meters with electro-mechanical displays, such as stepper motors and impulse counters. A precision oscillator, that replaces an external crystal is integrated on chip.

Two current sensor inputs allow the measurement of energy consumption on both the live and neutral.

Direction detection of energy flow as well as other common tamper conditions are flagged.

The power consumption on both the live and neutral are continuously measured and the larger of the two is selected for energy metering.

The SA2007M drives the calibration LED, the indicator LEDs and the electro-mechanical counter directly.

The SA2007M integrated circuit is available in 20 pin dual-in-line plastic (DIP-20) and small outline (SOIC-20) package types.

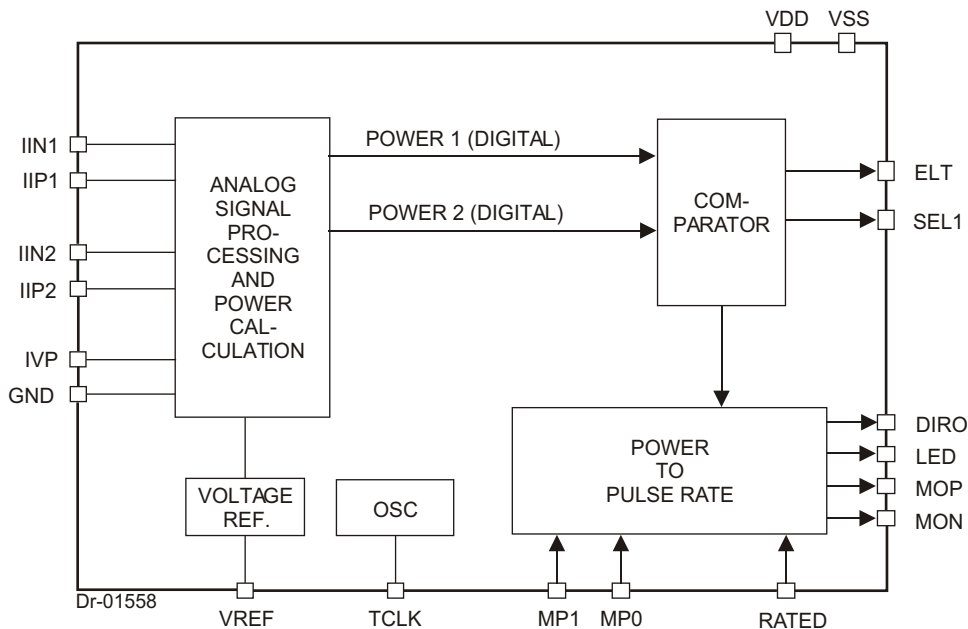

Figure 1: Block diagram

**ELECTRICAL CHARACTERISTICS**(V_{DD} = 2.5V, V_{SS} = -2.5V, over the temperature range -10°C to +70°C#, unless otherwise specified.)

Parameter	Symbol	Min	Typ	Max	Unit	Condition
Operating temp. Range	T _O	-25		+85	°C	
Supply Voltage: Positive	V _{DD}	2.25		2.75	V	
Supply Voltage: Negative	V _{SS}	-2.75		-2.25	V	
Supply Current: Positive	I _{DD}	4.1	5.8	8.2	mA	
Supply Current: Negative	I _{SS}	4.1	5.8	8.2	mA	
Current Sensor Inputs (Differential)						
Input Current Range	I _{II}	-25		+25	µA	Peak value
Voltage Sensor Input (Asymmetrical)						
Input Current Range	I _{IV}	-25		+25	µA	Peak value
Pin VREF						
Ref. Current	-I _R	45	50	55	µA	With R = 24k connected to V _{SS} Reference to V _{SS}
Ref. Voltage	V _R	1.1		1.3	V	
Digital I/O						
Pins DIRO, LED, MON, MOP Output High Voltage Output Low Voltage	V _{OH} V _{OL}	V _{DD} -1		V _{SS} +1	V V	I _{OH} = -2mA I _{OL} = 5mA
Pins MP0, MP1, TCLK, RATED, SEL1, ELT Input High Voltage Input Low Voltage	V _{IH} V _{IL}	V _{DD} -1		V _{SS} +1	V V	
Pin RATED Pin scan current**	I _{IH} -I _{IL}	3.1 2		7 4.6	mA mA	V _I = V _{DD} V _I = V _{SS}
Pins MP0, MP1, TCLK Pull down current	I _{IH}	48		110	µA	V _I = V _{DD}

#Extended Operating Temperature Range available on request.

** Switched to pin-scan mode every 1.1 seconds for 71µs.

ABSOLUTE MAXIMUM RATINGS*

Parameter	Symbol	Min	Max	Unit
Supply Voltage	V _{DD} -V _{SS}	3.6V	6.0	V
Current on any pin	I _{PIN}	-150	+150	mA
Storage Temperature	T _{STG}	-40	+125	°C
Operating Temperature	T _O	-25	+85	°C

*Stresses above those listed under "Absolute Maximum Ratings" may cause permanent damage to the device. This is a stress rating only. Functional operation of the device at these or any other condition above those indicated in the operational sections of this specification, is not implied. Exposure to Absolute Maximum Ratings for extended periods may affect device reliability.

**PIN DESCRIPTION**

PIN	Designation	Description
20	GND	Analog Ground. The voltage to this pin should be mid-way between V_{DD} and V_{SS} .
8	V_{DD}	Positive supply voltage. The voltage to this pin is typically +2.5V if a shunt resistor is used for current sensing or in the case of a current transformer a +5V supply can be applied.
14	V_{SS}	Negative supply voltage. The voltage to this pin is typically -2.5V if a shunt resistor is used for current sensing or in the case of a current transformer a 0V supply can be applied.
19	IVP	The current into the A/D converter should be set at $14\mu A_{RMS}$ at nominal mains voltage. The voltage sense input saturates at an input current of $\pm 25\mu A$ peak.
1, 2, 3, 4	IIN1, IIP1 IIN2, IIP2	Inputs for current sensor - channel 1 and channel 2. The shunt resistor voltage from each channel is converted to a current of $16\mu A_{RMS}$ at rated conditions. The current sense input saturates at an input current of $\pm 25\mu A$ peak.
5	VREF	This pin provides the connection for the reference current setting resistor. A 24k resistor connected to V_{SS} sets the optimum operating condition.
6, 7	MP0, MP1	Motor pulse rate select inputs. Described under Input Signals.
9, 12	MON, MOP	Motor pulse outputs. These outputs can be used to drive an impulse counter or stepper motor directly.
13	LED	Calibration LED output. Refer to section Led Output (LED) for the pulse rate output options.
15	RATED	Rated condition select input. Described under Input Signals.
16	SEL1	Current channel select output. This output indicates which channel is been used for kWh metering.
17	ELT	Earth loop tamper output. This output indicates an earth loop tamper condition.
18	DIRO	Direction output. This output indicates the energy flow direction.
11	NC	No Connection.
10	TCLK	Test input. Connect to V_{SS} for normal operation.

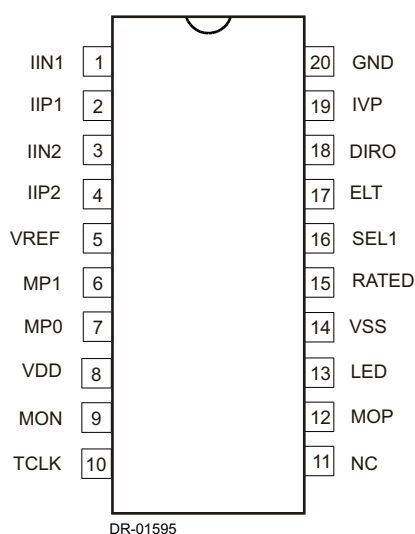
**ORDERING INFORMATION**

Part Number	Package
SA2007MPA	DIP-20
SA2007MSA	SOIC-20

Figure 2: Pin connections: Package: DIP-20, SOIC-20

FUNCTIONAL DESCRIPTION

The SA2007M is a CMOS mixed signal analog/digital integrated circuit, which performs power/energy calculations across a power range of 1000:1, to an overall accuracy of better than Class 1.

The integrated circuit includes all the required functions for 1-phase power and energy measurement such as oversampling A/D converters for the voltage and current sense inputs, power calculation and energy integration. Internal offsets are eliminated through the use of cancellation procedures. The SA2007M incorporates an anti-tamper scheme by continuously measuring the power consumption on both LIVE and NEUTRAL lines. A fault is indicated when these measurements differ by more than 12.5%. The SA2007M generates pulses with a frequency proportional to the larger of the two current measurements. The source (LIVE or NEUTRAL) for these pulses is indicated on the SEL1 pin.

Frequency outputs (MOP, MON and LED) are available. The pulse rate on these pins follows the instantaneous active power consumption measured.

A low voltage stepper may be driven directly from the device by connecting it between the MOP and MON pins, alternatively an impulse counter may be driven directly by connecting it between MOP and V_{SS} .

POWER CALCULATION

In Figure 6, the voltage drops across the current transformers terminating resistors are converted to currents for each current sense input, by means of resistors R_{10} and R_{11} (channel 1) as well as R_{12} and R_{13} (channel 2). The current sense input saturates at an input current of $\pm 25\mu\text{A}$ peak.

The mains voltage (230VAC) is divided down through a divider to $14V_{RMS}$. The current into the A/D converter input is set at $14\mu\text{A}_{RMS}$ at nominal mains voltage, via resistor R_7 (1M).

Different pulse rates are available at the MOP and MON pins. The device can be programmed for a 1, 10 or 100 dividing ratio for this output (counter resolution), depending on the status of the motor pulse rate select pins MP0 and MP1.

The rated condition select pin allows the metering constants (LED output and Motor Drive output) to remain unchanged for different rated conditions having a 1:2:3 scaling ratio, for example 230V/20A, 230V/40A and 230V/60A. This facility allows meter manufacturers to cater for a wide range of metering applications with minimal design changes.

ANALOG INPUT CONFIGURATION

The input circuitry of the current and voltage sensor inputs are illustrated below.

These inputs are protected against electrostatic discharge through clamping diodes.

The feedback loops from the outputs of the amplifiers A_I and A_V generate virtual shorts on the signal inputs. Exact duplications of the input currents are generated for the analog signal processing circuitry.

ELECTROSTATIC DISCHARGE (ESD) PROTECTION

The SA2007M integrated circuit's input's/outputs are protected against ESD.

POWER CONSUMPTION

The power consumption rating of the SA2007M integrated circuit is less than 40mW.

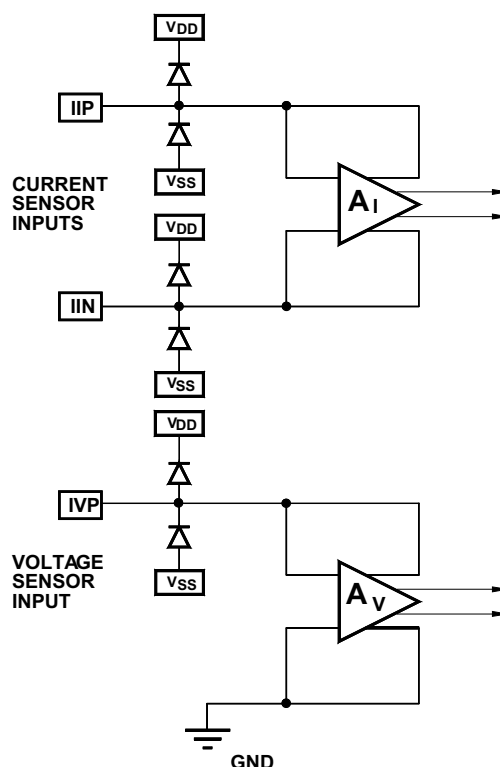

DR-01288

Figure 3: Analog input internal configuration



SA2007M

INPUT SIGNALS

VREF

The bias resistor of 24k optimum bias and reference conditions on chip. Calibration of the SA2007M should be done on the voltage input as described in Typical Application.

Rated condition select (RATED)

The rated condition select pin allows the metering constants (LED output and Motor Drive output) to remain unchanged for different rated conditions having a 1:2:3 scaling ratio, for example 230V/20A, 230V/40A and 230V/60A. This option allows for the development of different rated meters requiring minimal changes. The only changes to be implemented is the selection of the current sense resistors for the expected rated load currents and the selection of pins RATED, MP1 and MP0.

RATED pin	Rated Conditions Multiplying Ratio
V _{SS}	1/3
OPEN	2/3
V _{DD}	3/3

At a rated condition of 230V/60A (13800W), setting the RATED pin to VDD (ratio set to 3/3) the LED pulse rate will be 6400 pulses/KWh. With a combination of RATED, MP0 and MP1 settings, various rated condition can easily be met. Refer to the section "Using the RATED, MP0 and MP1 inputs" for further information.

Motor pulse rate select (MP1 and MP0)

The MP1 and MP2 inputs select between 1, 10 and 100 dividing ratio for the motor drive outputs (counter resolution). Please note that the device will not perform metering functions while in test mode.

The following table shows the combinations for some the common rated conditions:

RATED Pin	Rated Condition	LED output (Pulses / kWh)	Motor Pulse Rate		
			MP1 pin	MP0 pin	Pulse / kWh
V _{SS}	230V / 10A (2300 watts)	12800	V _{SS}	V _{SS}	4
			V _{SS}	V _{DD}	40
			V _{DD}	V _{SS}	400
V _{SS}	230V / 20A (4600 watts)	6400	V _{SS}	V _{SS}	2
			V _{SS}	V _{DD}	20
			V _{DD}	V _{SS}	200
Open	230V / 40A (9200 watts)	6400	V _{SS}	V _{SS}	2
			V _{SS}	V _{DD}	20
			V _{DD}	V _{SS}	200
V _{DD}	230V / 60A (13800 watts)	6400	V _{SS}	V _{SS}	2
			V _{SS}	V _{DD}	20
			V _{DD}	V _{SS}	200
Open	230V / 80A (18400 watts)	3200	V _{SS}	V _{SS}	1
			V _{SS}	V _{DD}	10
			V _{DD}	V _{SS}	100

Pulse Rate Selection Input		Counter resolution
MP1	MP0	
V _{DD}	V _{SS}	1
V _{SS}	V _{DD}	10
V _{SS}	V _{SS}	100
V _{DD}	V _{DD}	Test Mode

Using the RATED, MP1 and MP0 inputs

The following formulas can be used to calculate the LED output and motor pulse rates. **Note that for the motor pulse rates shown in the datasheet a MOP pulse followed by a MON pulse is treated as two energy pulses.**

$$\text{LED pulses per kWh} = 25.04 \times \text{Rated pin} \times \left[\frac{3600}{I_{\text{max}} \times V_{\text{nom}}} \right] \times 1000$$

Where:

I_{max} = Meters maximum rated current

V_{nom} = Meters nominal voltage

Rated pin = 1/3, 2/3 or 3/3 (see rated conditions select pin section)

$$\text{Motor pulse rate} = \frac{\text{LED pulses per kWh}}{64} \times \frac{1}{\text{resolution}}$$

Where:

Resolution = 1, 10 or 100 (see motor pulse select rate section)



SA2007M

sames

The LED pulse is not restricted to the rates mentioned in the above table. Using the formulae's on page 5, different combinations can be achieved as shown in the following table.

I _{max} (at 230V)	RATED PIN		
	V _{ss}	OPEN	V _{dd}
10	12800	25600	38400
20	6400	12800	19200
30	4566	8533	12800
40	3200	6400	9600
60	2133	4266	6400
80	1600	3200	4800
100	1066	2133	3200

A suitable motor pulse rate can be selected from the following table:

LED Pulse rate	Motor pulse rate (as per MP0 and MP1 settings)		
3200	1	10	100
6400	2	20	200
12800	4	40	400
25600	8	80	800

OUTPUT SIGNALS

Motor output (MOP, MON)

The MON pulse will follow the MOP pulse within 142ms. This prevents that the motor armature is in the wrong position after a power failure. A low voltage stepper may be driven directly from the device by connecting it between the MOP and MON pins, alternatively an impulse counter may be driven directly by connecting it between MOP and V_{SS}. Both MOP and MON outputs are active high. The motor drive wave forms are shown below:

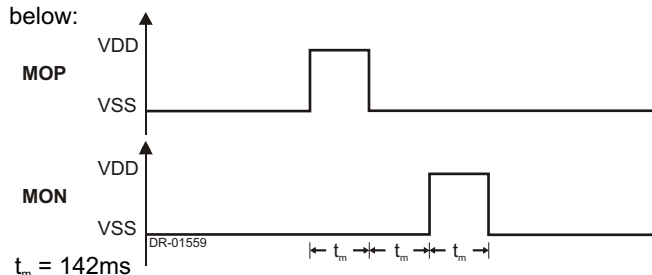

Figure 4: Motor drive waveform

LED output (LED)

The LED output is active low. Refer to the section "Using the RATED MP1 and MP0 inputs" to calculate the LED pulse rate. The LED waveform is shown below:

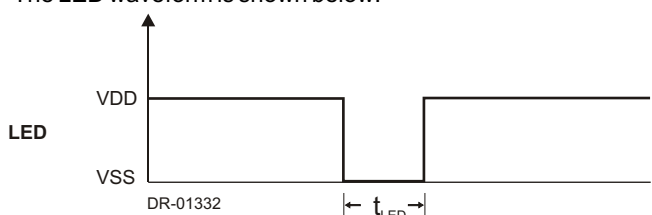

Figure 5: LED pulse output

An integrated anti-creep function prevents any output pulses if the measured power is less than 0.02% of the meters rated current.

Selected input indicator (SEL1)

The SA2007M continuously compares the power consumptions on current channel 1 inputs and current channel 2 inputs. The larger of the two measurements are used for metering. The SEL1 output pin indicates which channel is currently being used for the pulse output.

Switching between channels will not be faster than once per second when both channels are balanced.

Signal Output	Value	Description
SEL 1	0	Channel 1 selected (IIN1/IIP1)
	1	Channel 2 selected (IIN2/IIP2)

Earth loop tamper indication (ELT)

If the power measurements from both current channels differ by more than 12.5%, (indicating a earth loop tamper condition), the ELT output is set to zero. The SA2007M continues to generate output pulses from the larger of the two measured powers in this condition. The ELT output is active low.

Direction indication (DIRO)

The SA2007M provides information about the energy flow direction of both current channels on pin DIRO .

A logic 0 on pin DIRO indicates reverse energy flow of both current channels. Reverse energy flow is defined as the condition where the voltage sense input and current sense input are out of phase (greater than 90 degrees).

Positive energy flow, when voltage sense and both current sense input are in phase, is indicated on pin DIRO as a logic 1.

The DIRO output will toggle between 1 and 0 a rate of 1Hz when one of the current channels measure positive energy and the other negative energy. This condition may occur with a improper installed or tampered meter.

The DIRO pin may be used to drive a LED in order to indicate reverse energy.

Signal Output	Value	Description
DIRO	0	Reverse energy flow
	1	Forward energy flow
	1Hz	Out of phase current channels



TYPICAL APPLICATION

The analog (metering) interface described in this section is designed for measuring 230V/60A with precision better than Class 1.

The most important external components for the SA2007M integrated circuit are the current sense resistors, the voltage sense resistors and the bias setting resistor. The resistors used in the metering section should be of the same type so temperature effects are minimized.

Current Input IIN1, IIP1, IIN2, IIP2

Two current transformers are used to measure the current in the live and neutral phases. The output of the current transformer is terminated with a low impedance resistor. The voltage drop across the termination resistor is converted to a current that is fed to the differential current inputs of the SA2007M.

CT Termination Resistor

The voltage drop across the CT termination resistor at rated current should be at least 20mV. The CTs have low phase shift and a ratio of 1:2500. The CT is terminated with a 3.6 resistor giving a voltage drop of 86.4mV across the termination resistor at rated conditions (I_{max} for the meter).

The termination resistor on the second current channel is adjustable by means of P2 to facilitate channel equalization calibration. The termination resistor is chosen so that a 10 trimpot in parallel will provide a sufficient channel range.

Current Sensor Input Resistors

The resistors R10, R11 and R12, R13 define the current level into the current sense inputs of the SA2007M. The resistor values are selected for an input current of 16µA on the current inputs of the SA2007M at rated conditions. For a 60A meter at 2500:1 CT the resistor values are calculated as follows:

$$R10 = R11 = (I_L / 16\mu A) \times R_{SH} / 2 \\ = 60A / 2500 / 16\mu A \times 3.6 / 2 \\ = 2.7k$$

I_L = Line current

RSH = CT Termination resistor

2500 = CT ratio

The two current channels are identical so R10 = R11 = R12 = R13.

Voltage Input IVP

The voltage input of the SA2007M (IVP) is driven with a current of 14µA at nominal mains voltage. The voltage input saturates

at approximately 17µA. At a nominal voltage current of 14µA allows for 20% overdriving. The mains voltage is divided with a voltage divider to 14V that is fed to the voltage input pins via a 1M resistor.

Voltage Divider

The voltage divider is calculated for a voltage drop of 14V. Equations for the voltage divider are:

$$RA = R1 + R2 + R3 \\ RB = R7 || (R5 + P1)$$

A 5k trimpot will be used in the voltage channel for meter calibration. The center position on the pot is used in the calibration P1 = 2.5k .

Combining the two equations gives:

$$(RA + RB) / 230V = RB / 14V$$

Values for resistors R5 = 22k , P1 = 2.5k and R7 = 1M is chosen.

Substituting the values result in:

$$RB = 23.9k \\ RA = RB \times (230V / 14V - 1) \\ RA = 369k .$$

Standard resistor values of R1, R2 and R3 are chosen to be 120k , 120k and 130k .

The capacitor C1 is used to compensate for phase shift between the voltage sense inputs and the current sense inputs of the device, in cases where CTs with phase errors are used. The phase shift caused by the CT may be corrected by inserting a capacitor in the voltage divider circuit. To compensate for a phase shift of 0.18 degrees the capacitor value is calculated as follows:

$$C = 1 / (2 \times \text{Mains frequency} \times R5 \times \tan(\text{Phase shift angle})) \\ C = 1 / (2 \times 50 \times 1M \times \tan(0.18 \text{ degrees})) \\ C = 1.013\mu F$$

Reference Voltage Bias resistor

R6 defines all on chip and reference currents. With R6 = 24k optimum conditions are set. Device calibration is done on the voltage input of the device.

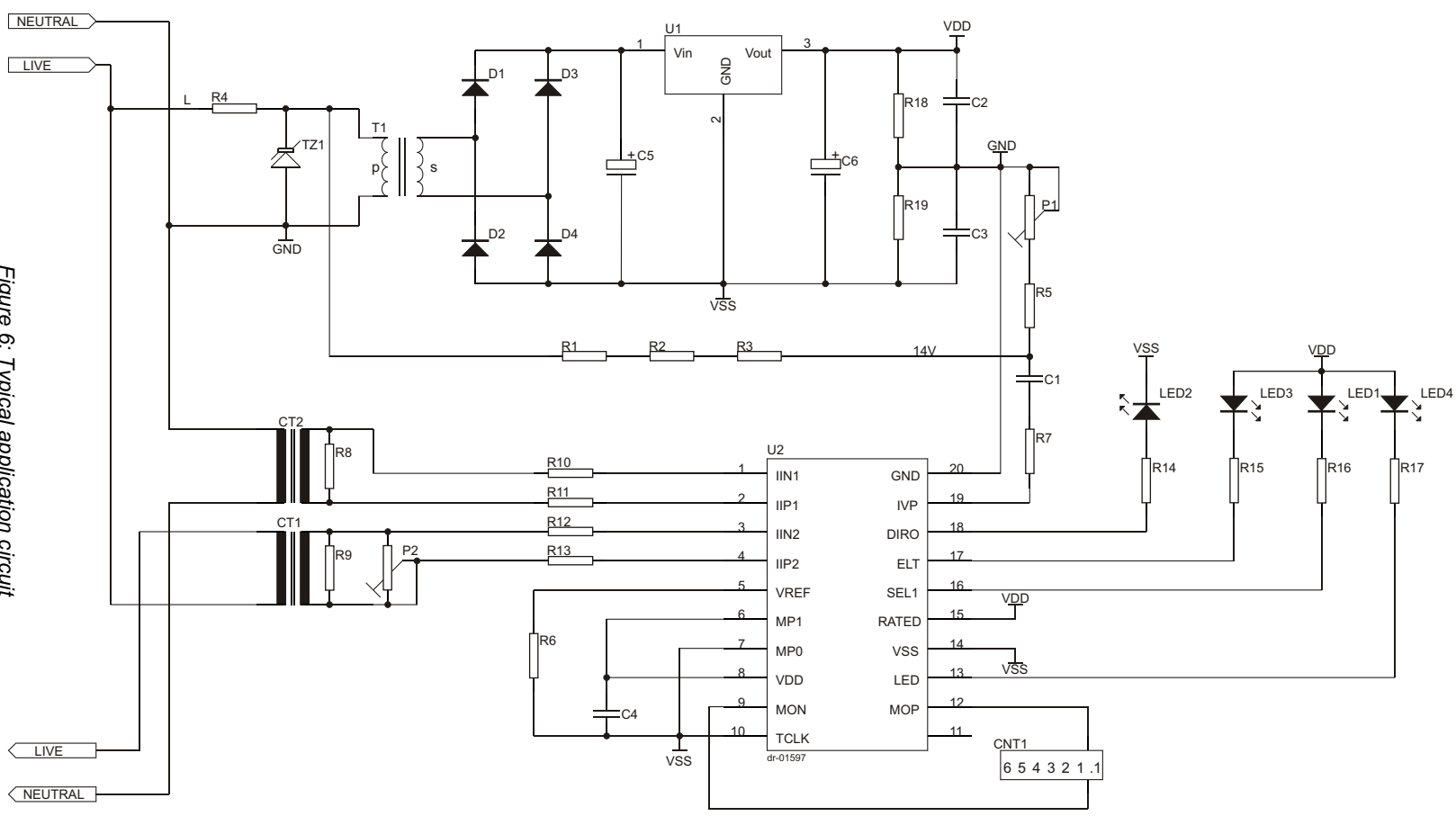

Figure 6: Typical application circuit



Parts List for Application Circuit: Figure 6

Item	Symbol	Description	Detail
1	U2	SA2007M	DIP-20/SOIC-20
2	D1	Diode, Silicon 1N4148	or Similar
3	D2	Diode, Silicon 1N4148	or Similar
4	D3	Diode, Silicon 1N4148	or Similar
5	D4	Diode, Silicon 1N4148	or Similar
6	LED1	Light emitting diode, Amber	
7	LED2	Light emitting diode, Green	
8	LED3	Light emitting diode, Red	
9	LED4	Light emitting diode, Green	
10	R1	Resistor, 120k, 1/4W, 1%, metal	
11	R2	Resistor, 120k, 1/4W, 1%, metal	
12	R3	Resistor, 130k, 1/4W, 1%, metal	
13	R4	Resistor, 10 Ω , 2W, Wire wound	
14	R5	Resistor, 24k, 1/4W, 1%, metal	
15	R6	Resistor, 24k, 1/4W, 1%, metal	
16	R7	Resistor, 1M, 1/4W, 1%, metal	
17	R8	Resistor, 1/4W, 1%, metal	Note 2
18	R9	Resistor, 1/4W, 1%, metal	Note 2
19	R10	Resistor, 1/4W, 1%, metal	Note 1
20	R11	Resistor, 1/4W, 1%, metal	Note 1
21	R12	Resistor, 1/4W, 1%, metal	Note 1
22	R13	Resistor, 1/4W, 1%, metal	Note 1
23	R14	Resistor, 1k, 1/4W, 5%	
24	R15	Resistor, 1k, 1/4W, 5%	
25	R16	Resistor, 1k, 1/4W, 5%	
26	R17	Resistor, 1k, 1/4W, 5%	
27	R18	Resistor, 1k, 1/4W, 5%, metal	
28	R19	Resistor, 1k, 1/4W, 5%, metal	
29	P1	Multi-turn, Trim pot, 10k	Note 2
30	P2	Multi-turn, Trim pot, 10	
31	C1	Capacitor	Note 4
32	C2	Capacitor, 220nF	
33	C3	Capacitor, 220nF	
34	C4	Capacitor, 820nF	Note 3
35	C5	Capacitor, 2200 μ F, 25V, electrolytic	
36	C6	Capacitor, 100 μ F, 16V, electrolytic	
37	CT1	Current Transformer	
38	CT2	Current Transformer	
39	T1	Transformer, 230V/9V	
40	U1	78LC05, Voltage regulator	
41	CNT1	Bipolar step motor	
42	TZ1	400V, Metal oxide varistor	

Note 1: Resistor (R10, R11, R12 and R13) values are dependent upon the selected value of R8 and R9

Note 2: See TYPICAL APPLICATION when selected the value of R8 and R9.

Note 3: Capacitor (C4) to be positioned as closed to Supply Pins (V_{DD} & V_{SS}) of U-1, as possible.

Note 4: Capacitor (C1) selected to minimize phase error introduced by current transformer (typically 1.5 μ F for normal CTs)



sames

SA2007M

DISCLAIMER:

The information contained in this document is confidential and proprietary to South African Micro-Electronic Systems (Pty) Ltd ("SAMES") and may not be copied or disclosed to a third party, in whole or in part, without the express written consent of SAMES. The information contained herein is current as of the date of publication; however, delivery of this document shall not under any circumstances create any implication that the information contained herein is correct as of any time subsequent to such date. SAMES does not undertake to inform any recipient of this document of any changes in the information contained herein, and SAMES expressly reserves the right to make changes in such information, without notification, even if such changes would render information contained herein inaccurate or incomplete. SAMES makes no representation or warranty that any circuit designed by reference to the information contained herein, will function without errors and as intended by the designer.

Any sales or technical questions may be posted to our e-mail address below:
energy@sames.co.za

For the latest updates on datasheets, please visit our web site:
<http://www.sames.co.za>.

SOUTH AFRICAN MICRO-ELECTRONIC SYSTEMS (PTY) LTD

Tel: (012) 333-6021
Tel: Int +27 12 333-6021
Fax: (012) 333-8071
Fax: Int +27 12 333-8071

**P O BOX 15888
33 ELAND STREET
LYNN EAST 0039
REPUBLIC OF SOUTH AFRICA**

**33 ELAND STREET
KOEDOESPOORT INDUSTRIAL AREA
PRETORIA
REPUBLIC OF SOUTH AFRICA**