

Single Phase Kilowatt-hour Metering IC for Mechanical Display Applications



Sames

SA2002D

FEATURES

- Provides a single chip solution for energy meters having a mechanical display
- No external crystal or resonator required
- Direct stepper motor / impulse counter drive
- Unidirectional and bi-directional energy measurement
- Meets the IEC 521/1036 Specification requirements for Class 1 AC Watt hour meters
- Configurable for different meter ratings
- Adaptable to different types of current sensors
- Precision voltage reference on chip
- Operates over a wide temperature range
- Low power consumption

DESCRIPTION

The SAMES SA2002D provides a single chip solution for single phase energy meters. Very few external components are required and it has direct drive capability for electromechanical counters. The SA2002D does not require an external crystal. A precision oscillator, which supplies the circuitry with a stable frequency, is integrated on chip.

Programmable inputs allow the meter manufacturer to configure the SA2002D for different meter ratings without having to change the stepper motor or impulse counter gear ratio. A high frequency pulse output is available at the LED output for meter calibration purposes. The SA2002D includes an anti-creep feature.

The SA2002D can be configured for positive, negative or bi-directional energy measurement.

The SA2002D Single Phase kWh metering integrated circuit generates a pulse rate output, the frequency of which is proportional to the power consumption. The SA2002D performs the calculation for active power. The method of calculation takes the power factor into account.

The SA2002D integrated circuit is available in 20 pin dual-in-line plastic (PDIP20), as well as 20 pin small outline (SOIC20) package types.

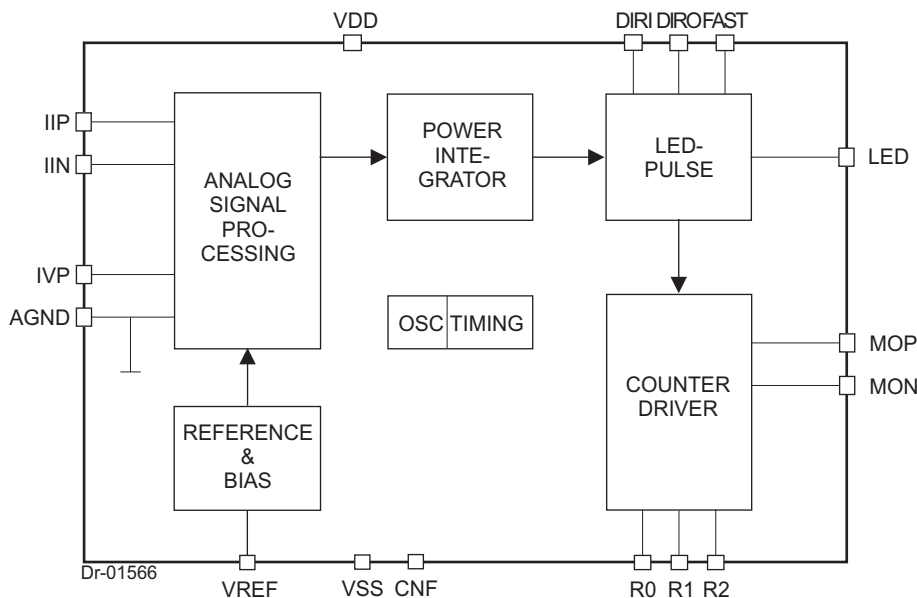

Figure 1: Block diagram

**ELECTRICAL CHARACTERISTICS**(V_{DD} = 2.5V, V_{SS} = -2.5V, over the temperature range -10°C to +70°C[#], unless otherwise specified.)

Parameter	Symbol	Min	Typ	Max	Unit	Condition
Operating temp. Range	T _O	-25		+85	°C	
Supply Voltage: Positive	V _{DD}	2.25		2.75	V	
Supply Voltage: Negative	V _{SS}	-2.75		-2.25	V	
Supply Current: Positive	I _{DD}	2.5	3.6	5	mA	
Supply Current: Negative	I _{SS}	2.5	3.6	5	mA	
Current Sensor Inputs (Differential)						
Input Current Range	I _{II}	-25		+25	µA	Peak value
Voltage Sensor Input (Asymmetrical)						
Input Current Range	I _{IV}	-25		+25	µA	Peak value
Pin VREF						
Ref. Current	-I _R	45	50	55	µA	With R = 24kΩ connected to V _{SS} Reference to V _{SS}
Ref. Voltage	V _R	1.1		1.3	V	
Digital I/O						
Pin R0, R1, R2, DIR1, CNF Input High Voltage Input Low Voltage	V _{IH} V _{IL}	V _{DD} -1		V _{SS} +1	V V	
Pin MOP, MON, LED, DIRO Output High Voltage Output Low Voltage	V _{OH} V _{OL}	V _{DD} -1		V _{SS} +1	V V	

#Extended Operating Temperature Range available on request.

ABSOLUTE MAXIMUM RATINGS*

Parameter	Symbol	Min	Max	Unit
Supply Voltage	V _{DD} -V _{SS}	3.2	6.0	V
Current on any pin	I _{PIN}	-150	+150	mA
Storage Temperature	T _{STG}	-40	+125	°C
Operating Temperature	T _O	-25	+85	°C

*Stresses above those listed under "Absolute Maximum Ratings" may cause permanent damage to the device. This is a stress rating only. Functional operation of the device at these or any other condition above those indicated in the operational sections of this specification, is not implied. Exposure to Absolute Maximum Ratings for extended periods may affect device reliability.

**PIN DESCRIPTION**

PIN	Designation	Description
20	AGND	Analog Ground. The supply voltage to this pin should be mid-way between V_{DD} and V_{SS} .
8	V_{DD}	Positive supply voltage. The voltage to this pin is typically +2.5V if a shunt resistor is used for current sensing or in the case of a current transformer a +5V supply can be applied.
14	V_{SS}	Negative supply voltage. The voltage to this pin is typically -2.5V if a shunt resistor is used for current sensing or in the case of a current transformer a 0V supply can be applied.
19	IVP	Analog Input for Voltage. The current into the A/D converter should be set at $14\mu A_{RMS}$ at nominal mains voltage. The voltage sense input saturates at an input current of $\pm 25\mu A$ peak.
1, 2	IIN, IIP	Inputs for current sensor. The shunt resistor voltage from each channel is converted to a current of $16\mu A_{RMS}$ at rated conditions. The current sense input saturates at an input current of $\pm 25\mu A$ peak.
3	VREF	This pin provides the connection for the reference current setting resistor. A $24k\Omega$ resistor connected to V_{SS} sets the optimum operating condition.
6, 5, 4	R0, R1, R2	Rated Condition Select. These inputs are used for the different rated condition configuration, including the LED frequency calibration pulse.
7	FAST	FAST calibration. The LED pulse rate change to 1252Hz at rated conditions if FAST is connected to V_{DD} .
9	CNF	Configure / Test input. For normal operation this pin must be connected to V_{SS} .
12, 15	MON, MOP	Motor pulse outputs. These outputs can drive an electromechanical counter directly.
13	LED	Calibration LED output. Refer to the rated condition select section of the pulse rate output options.
17	DIRO	Direction output. This output indicates the energy flow direction.
18	DIRI	Direction input. This input is used to enable either bi-directional or unidirectional energy measurement.
10,11,16	NC	No Connection

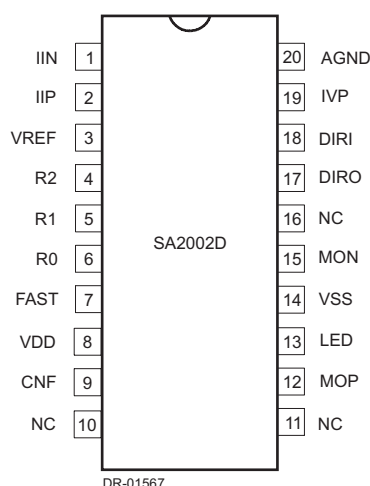
**ORDERING INFORMATION**

Part Number	Package
SA2002DPA	PDIP20
SA2002DSA	SOIC20

Figure 2: Pin connections: Package: PDIP20, SOIC20

FUNCTIONAL DESCRIPTION

The SA2002D is a CMOS mixed signal Analog/Digital integrated circuit, which performs power/energy calculations across a power range of 1000:1, to an overall accuracy of better than Class 1.

The integrated circuit includes all the required functions for 1-phase power and energy measurement such as two oversampling A/D converters for the voltage and current sense inputs, power calculation and energy integration. Internal offsets are eliminated through the use of cancellation procedures. The SA2002D generates pulses, the frequency of which is proportional to the power consumption. A complementary output (MOP and MON) is provided for the stepper motor. One energy pulse is represented by MOP pulse and subsequently followed by a MON pulse. This configuration avoids the possibility that, after power up, the first energy pulse is lost due to the stepper motor being in the wrong phase. The pulse rate on these pins follow the instantaneous active power consumption. The LED pulse output follows the average power consumption measured and is intended for calibration purposes.

POWER CALCULATION

In the Application Circuit (Figure 3), the voltage drops across the shunt will be between 0 and $16mV_{RMS}$ (0 to 80A through a shunt resistor of $200\mu\Omega$). The voltage is converted to a current of between 0 and $16mV_{RMS}$, by means of resistors R1 and R2. The current sense input saturates at an input current of $\pm 25\mu A$ peak.

For the voltage sensor input, the mains voltage (230VAC) is

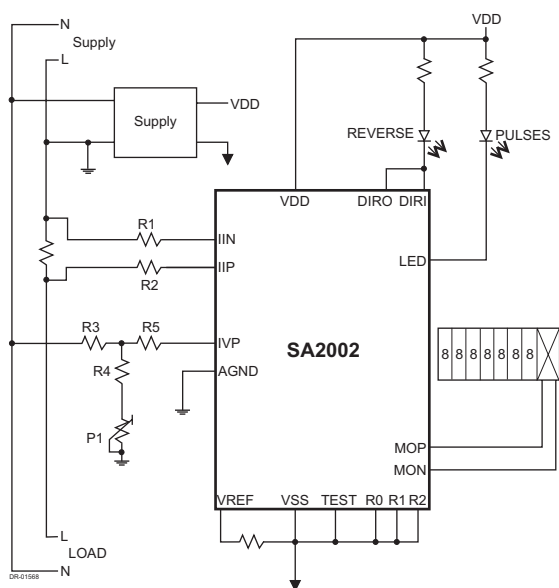

Figure 3: Application Circuit

divided down through a divider (R3, R4 and P1) to $14V_{RMS}$. The current into the A/D converter input is set at $14\mu A_{RMS}$ at nominal mains voltage, via resistor R5 ($1M\Omega$). P1 may be varied for calibration purposes.

The pulse rate available at the motor drive pins MOP and MON (counter resolution) is fixed at 100 (200) impulses/kWh*. The frequency of the LED pin is dependant on the settings of pins R0, R1 and R2, which allow a selection of different rated conditions. In this case (R0, R1 and R2 set to logic 0) the LED output is 6400 impulses/kWh, with the rated conditions set to 220V/10A. This facility allows meter manufacturers to cater for a wide range of metering applications with minimal design changes.

ANALOG INPUT CONFIGURATION

The input circuitry of the current and voltage sensor inputs is illustrated in figure 3.

These inputs are protected against electrostatic discharge through clamping diodes.

The feedback loops from the outputs of the amplifiers A_I and A_V generate virtual shorts on the signal inputs. Exact duplications of the input currents are generated for the analog signal processing circuitry.

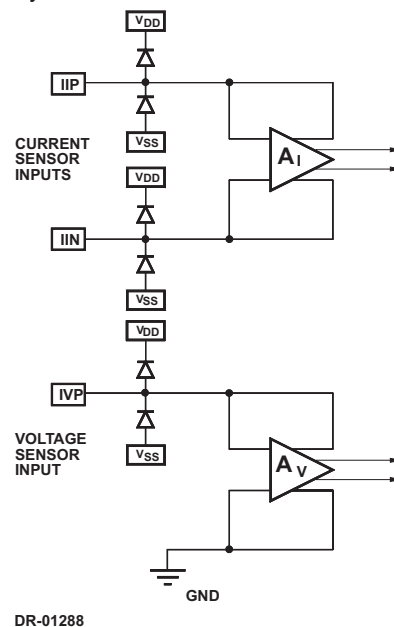

Figure 4: Analog Input Internal Configuration

*The figure not in parenthesis indicates that a MOP pulse followed by a MON pulse is treated as one energy pulse. The figure inside parenthesis means that a MOP pulse followed by a MON pulse is treated as two energy pulses.



The current and voltage sense inputs are both identical. Both inputs are differential current driven up to $\pm 25\mu\text{A}$ peak. One input of the voltage sense amplifier is internally connected to GND. This is possible because the voltage sense input is much less sensitive to externally induced parasitic signals compared to the current sense inputs.

ELECTROSTATIC DISCHARGE (ESD) PROTECTION

The SA2002D integrated circuit's inputs/outputs are protected against ESD.

POWER CONSUMPTION

The power consumption rating of the SA2002D integrated circuit is less than 25mW.

INPUT SIGNALS

VREF

A bias resistor of $24\text{k}\Omega$ sets optimum bias and reference conditions on chip. Calibration of the SA2002D should be done on the voltage input as described in Typical Applications.

Current sense input (IIP and IIN)

Figure 3 on page 4 shows the typical connections for the current sensor input. The resistor R1 and R2 define the current level into the current sense inputs of the SA2002D. At maximum rated current the resistor values should be selected for input currents of $16\mu\text{A}_{\text{RMS}}$.

The values for resistors R1 and R2 can be calculated as follows:

$$R1 = R2 = (I_L / 16\mu\text{A}) \times \text{RSH} / 2$$

Where I_L = Line current

RSH = Shunt resistor or termination

Resistor if a CT is used as the current sensor.

The value of RSH, if used as the CT's termination resistor, should be less than the DC resistance of the CT's secondary winding. The voltage drop across RSH should not be less than 16mV_{RMS} at rated currents.

Voltage Sense Input (IVP)

The current into the A/D converter should be set at $14\mu\text{A}_{\text{RMS}}$ at nominal mains voltage. The voltage sense input saturates at an input current of $\pm 25\mu\text{A}$ peak. Referring to Figure 3 the typical connections for the voltage sense input is illustrated. Resistors R3, R4 and R5 set the current for the voltage sense input. The mains voltage is divided down to 14V_{RMS} . The current into the A/D converter input is set at $14\mu\text{A}_{\text{RMS}}$ via resistor R5.

Rated condition select (R0, R1, R2)

The rated condition select pins R0, R1 and R2 are inputs, which configure the SA2002D for different rated conditions. This feature eliminates the need for different stepper motor gear ratios. The LED pulse output follows the average power consumption measured.

R2	R1	R0	Rated Condition	LED Output (Pulses/ KWh)	Motor Pulse Rate (Pulses/ KWh)*
0	0	0	220V/10A	6400	100 (200)
0	0	1	220V/20A	3200	100 (200)
0	1	0	220V/40A	1600	100 (200)
0	1	1	220V/80A	800	100 (200)
1	0	0	220V/6A	6400	100 (200)
1	0	1	220V/30A	3200	100 (200)
1	1	0	220V/60A	1600	100 (200)
1	1	1	Test Mode	Test Mode	-

Table 1

*This figure not in parenthesis indicates that a MOP pulse followed by a MON pulse is treated as one energy pulse. The figure inside parenthesis means that a MOP pulse followed by a MON pulse is treated as two energy pulses.

The Motor pulse rate is not restricted to 100 (200) pulses/kWh. The following examples show how different LED and motor pulse rates can be achieved:

Example 1. A manufacturer designing a 220V/10A meter can choose to have the pins R2, R1 and R0 connected as for a 220V/20A (R2=0, R1=0 and R0=1). In comparison to table 1 the Rated Condition is now half (2200W), this in turn doubles the LED and Motor Pulse output rates as shown in the following table:

R2	R1	R0	Rated Condition	LED Output (Pulses/ KWh)	Motor Pulse Rate (Pulses/ KWh)*
0	0	1	220V/10A	6400	100 (200)

Example 2. A manufacturer designing a 220V/80A meter can choose to have the pins R2, R1 and R0 connected as for a 220V/40A (R2=0, R1=0 and R0=1). In comparison to table 1 the Rated Condition has doubled (17600W), this in turn halves the LED and Motor Pulse output rates as shown in the following table:

R2	R1	R0	Rated Condition	LED Output (Pulses/ KWh)	Motor Pulse Rate (Pulses/ KWh)*
0	1	0	220V/80A	800	50 (100)



Direction input (DIRI)

The DIRI input pin allows the representation of the measured energy to be selected. The representation can be of any three types:

Positive Energy

Pulses are generated on the output if the energy flow is positive. Any negative energy (reverse energy) flow is disregarded.

Negative Energy

Pulses are generated on the output if the energy flow is negative. Any positive energy flow is disregarded. Negative energy flow is defined as the condition where the voltage sense input and current sense input are out of phase (greater than 90 degrees).

Bi-direct

Pulses are generated on the output if the energy flow is positive or negative. The energy direction may be ascertained by monitoring the DIRO pin.

Energy Direction Selection

DIRI	Direction
1	Positive
0	Negative
DIRO	Bi-direct

Fast Calibration (FAST)

The SA2002D may be put in a fast calibration mode by setting FAST to V_{DD}. In this mode the pulse rate is 1252Hz on the LED output at rated conditions.

OUTPUT SIGNALS

Motor Pulse Output (MOP, MON)

These outputs can be used to drive an electromechanical counter directly at 100 (200) impulses per kWh. See table 1.

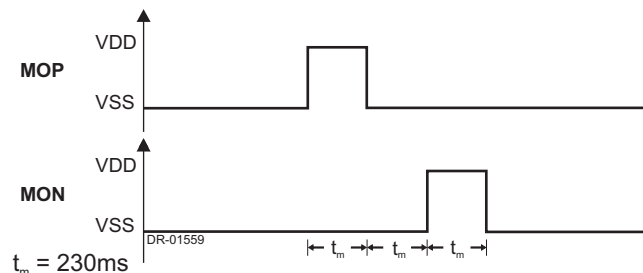

Figure 5: Motor output MON and MOP

LED Output (LED)

The LED pulse output follows the average power consumption measured and is intended for calibration purposes. The pulse rate is dependant on the settings of pins R0, R1 and R2 (see rated conditions select). The LED output is active low. The LED waveform is shown below:

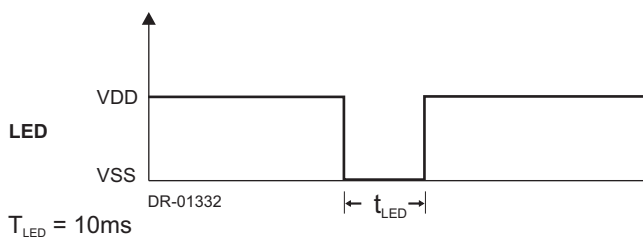

Figure 6: LED pulse output

An integrated anti-creep function prevents any output pulses if the measured power is less than 0.02% of the meters rated current.

Direction Indication (DIRO)

The SA2002D provides information about the energy flow direction on pin DIRO. A logic 0 on pin DIRO indicates reverse energy flow. Reverse energy flow is defined as the condition where the voltage sense input and current sense input are out of phase (90..270 degrees).

Positive energy flow, when voltage sense and current sense input are in phase, is indicated on pin DIRO as a logic 1.

The DIRO pin may be used to drive a LED in order to indicate reverse energy.



TYPICAL APPLICATION

In figure 7, the components required for stand alone power metering application, are shown. The application uses a shunt resistor for the mains current sensing. The meter is designed for 220V/40A I_{MAX} operation.

The most important external components for the SA2002D integrated circuit are the current sense resistors, the voltage sense resistors as well as the bias setting resistor.

BIAS RESISTOR

R13 defines all on-chip and reference currents. With R13=24kΩ, optimum conditions are set. Device calibration is done on the voltage input of the device.

SHUNT RESISTOR

The voltage drop across the shunt resistor at rated current should be at least 20mV. A shunt resistor with a value of 625μΩ is chosen. The voltage drop across the shunt resistor is 25mV at rated conditions (I_{max}). The power dissipation in the current sensor is:

$$P=(40A)^2 \times 625\mu\Omega = 1W.$$

CURRENT SENSE RESISTORS

The resistors R6 and R7 define the current level into the current sense inputs of the device. The resistor values are selected for an input current of 16μA on the current inputs of the SA2002D at rated conditions.

According to equation described in the Current Sense inputs section:

$$\begin{aligned} R6 = R7 &= (I_i / 16\mu A) \times R_{SH} / 2 \\ &= 40A / 16\mu A \times 625\mu\Omega / 2 \\ &= 781.25\Omega \end{aligned}$$

A resistor with value of 820Ω is chosen, the 5% deviation from the calculated value will be compensated for when calculating resistor values for the voltage path.

VOLTAGE DIVIDER

The voltage divider is calculated for a voltage drop of 14V + 5%(14.7V). Equations for the voltage divider in figure 7 are: R1+R2+R3=RA and R12 || (R11+P1)=RB. Combining the two equations gives:

$$(RA + RB) / 220V = RB / 14.7V$$

A 5k trimpot will be used in the voltage channel for meter calibration. The center position on the pot is used in the calculations. P1 = 2.5kΩ and values for resistors R11 = 22kΩ and R12 = 1MΩ is chosen.

Substituting the values will result in:

RB = 23.91kΩ and RA = RB x (230V/14.7V - 1) resulting in RA = 333kΩ so the resistor values of R1, R2 and R3 are chosen to be 110kΩ.

PROGRAMMING

The resistor values are calculated for a 40A rated meter. The LED pulse rate must be set accordingly by programming pins R0, R1 and R2. Using the table Rated Conditions Select (On page 5) pins R0 and R2 is set to V_{SS} and R1 set to V_{DD}. These settings will configure the SA2002D for 220V/40A operation with a LED pulse rate of 1600 pulses/kWh. The FAST pin is set to V_{SS} for normal operation.

Figure 7: Application Circuit

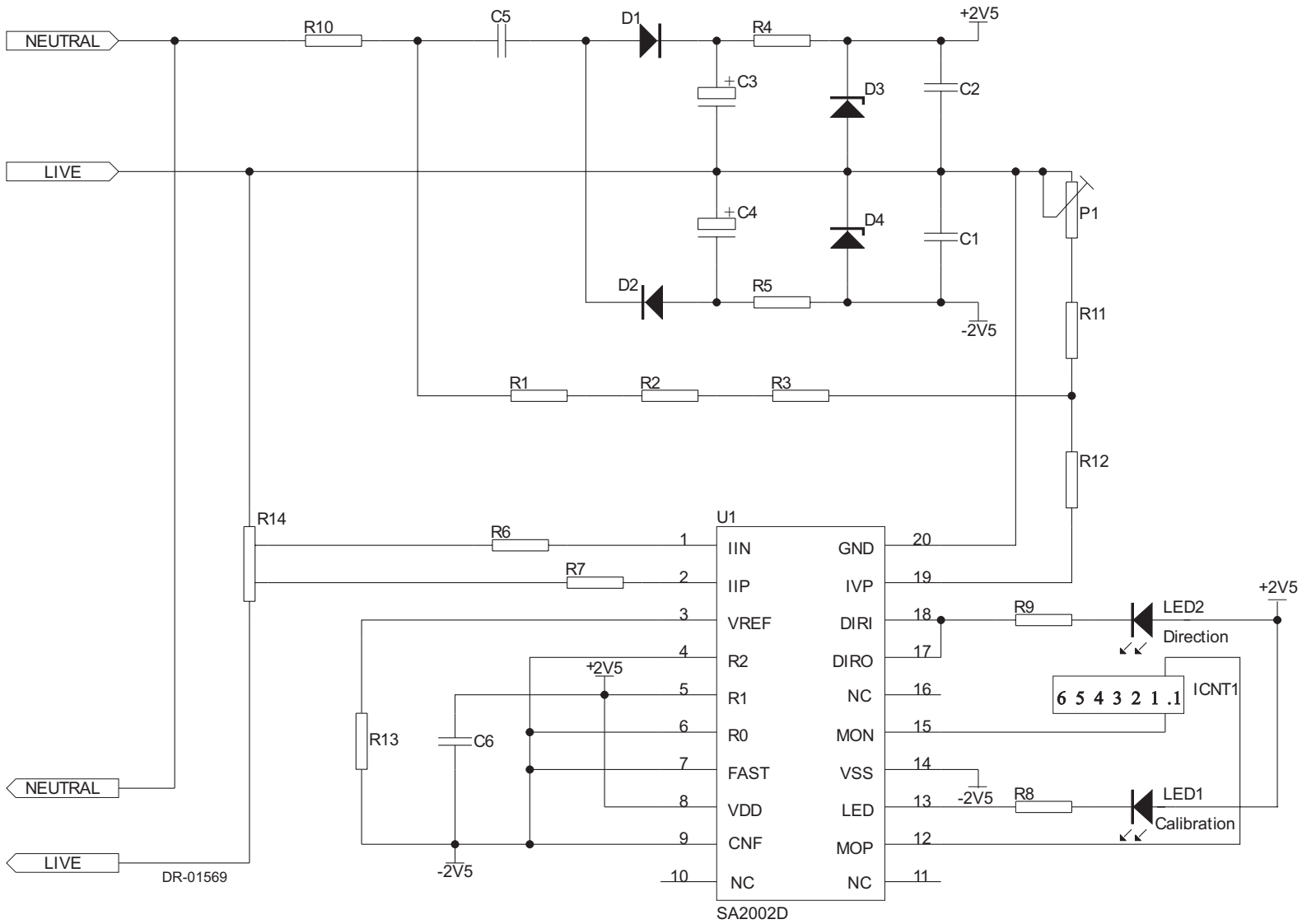

220V/40A meter with 1600 pulses/kWh resolution



**Parts List for Application Circuit: Figure 7**

Symbol	Description	Detail
U1	SA2002D	PDIP20/SOIC20
D1	Diode, Silicon, 1N4002	
D2	Diode, Silicon, 1N4002	
D3	Diode, Zener, 2.4V	
D4	Diode, Zener, 2.4V	
R1	Resistor, 110k, 1/4W, 1%, metal	
R2	Resistor, 110k, 1/4W, 1%, metal	
R3	Resistor, 110k, 1/4W, 1%, metal	
R4	Resistor, 680R, 1/4W, 1%, metal	
R5	Resistor, 680R, 1/4W, 1%, metal	
R6	Resistor, 820R, 1/4W, 1%, metal	Note 1
R7	Resistor, 820R, 1/4W, 1%, metal	Note 1
R8	Resistor, 680R, 1/4W	
R9	Resistor, 680R, 1/4W	
R10	Resistor, 47R, 2W, 5%, wire wound	
R11	Resistor, 22k 1/4W, 1%, metal	
R12	Resistor, 1M, 1/4W, 1%, metal	
R13	Resistor, 24k, 1/4W, 1%, metal	
R14	Shunt resistor 625 $\mu\Omega$	Note 1
P1	Trim pot, 5k, Multi turn	
C1	Capacitor, 220nF	
C2	Capacitor, 220nF	
C3	Capacitor, 100uF, 16V, electrolytic	
C4	Capacitor, 100uF, 16V, electrolytic	
C5	Capacitor, 330nF, 250VAC	
C6	Capacitor, 820nF	Note 2
LED1	3mm Light emitting diode	
LED2	3mm Light emitting diode	
ICNT1	Mechanical counter	

Note 1: Resistor (R6 and R7) values are dependant upon the selected shunt resistor (R14) value.

Note 2: Capacitor C6 to be positioned as close as possible to supply pins.

**DISCLAIMER:**

The information contained in this document is confidential and proprietary to South African Micro-Electronic Systems (Pty) Ltd ("SAMES") and may not be copied or disclosed to a third party, in whole or in part, without the express written consent of SAMES. The information contained herein is current as of the date of publication; however, delivery of this document shall not under any circumstances create any implication that the information contained herein is correct as of any time subsequent to such date. SAMES does not undertake to inform any recipient of this document of any changes in the information contained herein, and SAMES expressly reserves the right to make changes in such information, without notification, even if such changes would render information contained herein inaccurate or incomplete. SAMES makes no representation or warranty that any circuit designed by reference to the information contained herein, will function without errors and as intended by the designer.

Any sales or technical questions may be posted to our e-mail address below:
energy@sames.co.za

For the latest updates on datasheets, please visit our web site:
<http://www.sames.co.za>

SOUTH AFRICAN MICRO-ELECTRONIC SYSTEMS (PTY) LTD

Tel: (012) 333-6021
Tel: Int +27 12 333-6021
Fax: (012) 333-8071
Fax: Int +27 12 333-8071

**PO BOX 15888
LYNN EAST
0039
REPUBLIC OF SOUTH AFRICA**

**33 ELAND STREET
KOEDOESPOORT INDUSTRIAL AREA
PRETORIA
REPUBLIC OF SOUTH AFRICA**