

General Description

Optoi-Bee Z-master consists in a 802.15.4 standard compliant 2.4GHz transmitter unit (z-node OIS7) plus a master board (OIS8 or OIS12). The items together form a coordinator, which allows to build and supervise a wireless sensor's network. Any RFD can be connected to a coordinator. Each network needs at least one coordinator as a controller (i.e. OIS10-USB z-master), and up to 19 RFDs (see Figure 1 or application notes). In order to extend the network, more coordinators can be connected in a Modbus bus (a coordinator becomes a slave in Modbus protocol). The z-master data connection can be virtual COM port over USB or RS485. The communication protocol is Modbus (physically over RS-485 or USB wire). The power supply can be taken from USB or a standard 12-24V dc power supply.

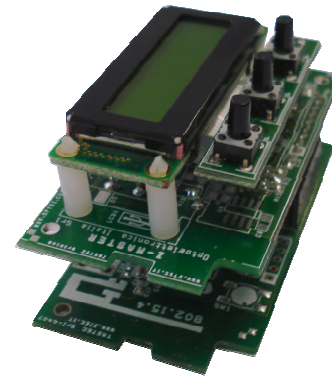

Figure 2 – Z-master module

Applications

Industrial environments
 Factory automation systems
 Home and industrial control
 Home automation
 Building automation
 Smart sensors network

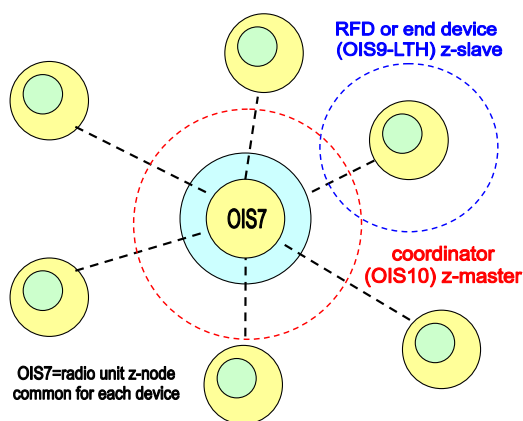

Figure 1 – Star network (1 coordinator and many RFD)

Features

- High distance range covered (≈ 30m without external antenna)
- 802.15.4 standard, unique MAC address
- Flexible and easy installation (compatible with standard wall boxes)
- Ecological (environmental power saving)
- Global band transmission (16 channels @ 2.4GHz)
- External SMA antenna option (it extends range more than 100m)
- Small dimensions (L=75,5mm W=36,5mm H=46,0mm)
- High sensitivity (up to -90dBm)
- Wide power supply range (8-30Vdc)
- Standard output protocol (Modbus RS-485)

Optoi-Bee WSN Ordering Information

OIS8	Master board: USB interface
OIS12	Master board: MODBUS interface
OIS7	802.15.4 transmission module (z-node board)
OIS10-USB	Complete z-master USB with integrated antenna
OIS10-MOD	Complete z-master MODBUS with integrated antenna

ABSOLUTE MAXIMUM RATINGS

Symbol	Parameter	Min	Max	Unit
T _A	Operating Temperature Range	-10	60	°C
V _{CC}	Supply Voltage Range (MODBUS version)	9	30	Vdc
	Supply Voltage Range (USB version)	4.5	9	Vdc
T _S	Storage Temperature	-25	85	°C

Stresses beyond those listed under "Absolute Maximum Ratings" may cause permanent damage to the device. These are stress ratings only, and functional operation of the device at these or any other conditions beyond those indicated in the operational sections of the specifications is not implied. Exposure to absolute maximum rated conditions for extended periods may affect device reliability.

ELECTRICAL Z-MASTER CHARACTERISTICS

T_A = 25°C, unless otherwise noted.

Symbol	Parameter	Conditions	Min	Typ	Max	Unit
V _{CC}	Supply Voltage Range	USB version	4.5	5	9	V
		MODbus version§	9		24	V
I _{CC}	Supply dc average current	USB version		45		mA
		MODbus version§		45		mA
d	Distance covered (FFD and RFD with integrated antenna)	outdoor		70		m
		indoor		30		m
d	Distance covered (FFD with external 5 dBi antenna and RFD with integrated antenna)	outdoor		300		m
		indoor		100		m

MODBUS Z-MASTER ELECTRICAL PARAMETERS

T_A = 25°C, unless otherwise noted.

Configure the application with this parameters in order to communicate to z-master.

Symbol	Parameter	Conditions	Min	Typ	Max	Unit
B	Baud rate			57600		Bps
D	Data bits			8		-
P	Parity			N		-
S	Stop bits			1		-
N°	Number of binded nodes allowable		1		19	-
addr	Address node number		0x0001		0x0013	

MODBUS Z-MASTER SOFTWARE TABLES

The RFD (sensors) data is stored into the coordinator's RAM as a structure like the one showed below:

RFD STRUCT

```
{
    WORD flags;          (flag field)
    WORD temp;          (temperature value)
    WORD lum;           (luminosity value)
    WORD hum;           (humidity value)
    WORD msg1;          (message 1)
    WORD msg2;          (message 2)
}
```

A structure like this is stored into the z-master's RAM, and it is repeated 19 times, for every RFD that could be connected to the coordinator. If more than 19 nodes per network are required, it is necessary to increase the coordinator's RAM memory size ** or extend the network for example adding another coordinator (38 nodes).

FLAG FIELD

The first word location (flags) contains some status node information, like:

- the active sensors are LTH (bit 0-2) ;
- RSSI (bit 3-7) ;
- battery level (bit 8-12) ;
- there are pending messages for a specific node (bit 13) → NOT IMPLEMENTED ;
- a new data has been updated (bit 14) ;
- the node is active (bit 15).

§ DC voltage only

** available on request

OIS10

The flag field is explained in the table below.

The lower byte for instances denotes the sensors board type. The typical value “0x07” means that the slave is an OIS9-LTH, that is a temperature, humidity and luminosity sensor node.

UPPER BYTE								LOWER BYTE								Flag Description
A	U	P	BATTERY					RSSI				L	H	T	A=active U=updated P=pending	
15	14	13	12	11	10	09	08	07	06	05	04	03	02	01	00	L=luminosity H=humidity T=temperature

In the table below it is possible to see the Modbus RAM locations (starting from address 40001), where the RFD’s information are stored.

RAM CONFIGURATION

Location	Parameter	Parameter	Description
40001	Reserved	Reserved	-
40002	Nodes 9-16	Nodes 1-8	Flags updated nodes
40003	Nodes 25-32	Nodes 17-24	Flags updated nodes
40004	Nodes 41-48	Nodes 33-40	Flags updated nodes
40005	Nodes 57-64	Nodes 49-56	Flags updated nodes
40006	Nodes 73-80	Nodes 65-72	Flags updated nodes
40007	Flags	Flags	Flags node 1
40008	Temp hi	Temp lo	Temperature value node 1
40009	Lum hi	Lum lo	Luminosity value node 1
40010	Hum hi	Hum lo	Humidity value node 1
40011	Msg1 hi	Msg1 lo	Message 1node 1
40012	Msg2 hi	Msg2 lo	Message 2node 1
40013	Flags	Flags	Flags node 2
...
40019	Flags	Flags	Flags node 3
...
40025	Flags	Flags	Flags node 4
...
44000	Modbus address	Max last net activity	††
44001	Binding mode	Tx power	

The area 40001-40006 is useful to know if there are new data. This area contains a copy of the flags indicating that the data is updated, the application software could watch this area first, in order to minimize the bus overhead.

†† This values are a copy of the eeprom, carried out to allow to modify it. After each change of one of this values, the OIS10 resets, in order to let changes to be effective.

READ EXAMPLE

This is an example of reading procedure: send the following frame:

0x01	0x03	0x00	0x06	0x00	0x06	0x25	0xC9
Byte 1	Byte 2	Byte 3	Byte 4	Byte 5	Byte 6	Byte 7	Byte 8

In specific this frame reads the first node parameters:

- the MSB (byte1) indicates the z-master short address;
- the second means that this is a command frame that wants to read in RAM;
- the third and fourth bytes indicates the start RAM address for reading (0x0006 means start from 0x0007);
- the fifth and sixth bytes represent the number of registers (words) to read;
- the last two bytes are the CRC-16 of the whole frame.

With this command it is read a memory area between addresses 40007 and 40012.

The master should reply with this frame:

0x01	0x03	0x0C	0xD7	0x07	0x00	0xF9	0x02	0x56	0x13	0x10	0x00	0x00	0x00	0x00	0xA4	0x99
Byte1	Byte2	Byte3	Byte4	Byte5	Byte6	Byte7	Byte8	Byte9	Byte10	Byte11	Byte12	Byte13	Byte14	Byte15	Byte16	Byte17

Meaning of reply frame:

- the MSB (byte 1) indicates the z-master short address;
- the second means that this is an answer of 0x03 type;
- the third byte indicates the number of the reading bytes;
- the fourth and fifth bytes represent the flags of node number 1;
- the sixth and seventh bytes are the temperature value of node number 1 (in tenth of Celsius degrees);
- the eighth and ninth bytes are the luminosity level of node number 1 (in lux);
- the tenth and eleventh bytes represent the humidity value of node number 1 (in 1/10000 of R.H.);
- the twelfth and thirteenth bytes are messages for node number 1 (NOT IMPLEMENTED);
- the last two bytes are CRC-16 of the whole frame. ‡‡

WRITE EXAMPLE

This is an example of writing procedure: send the following frame:

0x01	0x10	0x0F	0xA0	0x00	0x01	0x02	0x05	0xFF	0x87	0x0F
Byte 1	Byte 2	Byte 3	Byte 4	Byte 5	Byte 6	Byte 7	Byte 8	Byte 9	Byte 10	Byte 11

In specific this frame writes:

- the MSB (byte1) indicates the z-master MODBUS address;
- the second means that this is a command frame that wants to write in RAM (0x10 or 16, see Modbus specs.);
- the third and fourth bytes indicates the start RAM address for reading (0x0FA0 = 4000);
- the fifth and sixth bytes represent the number of registers (words) to write;
- the seventh indicates the number of bytes to write;

‡‡ For more details see Modbus protocol specifications

OIS10

- the eighth and ninth represent the data to be written in the register (please note that the MODBUS writes a word, so the writing frame affects 2 bytes);
- the last two bytes are the CRC-16 of the whole frame.

The command of the example is showing how to modify the modbus Z-master address from default of 0x01 to 0x05:

The master should replay with this frame at the command above:

0x01	0x10	0x0F	0xA0	0x00	0x01	0x05	0xFF	0xBD	0x64
Byte 1	Byte 2	Byte 3	Byte 4	Byte 5	Byte 6	Byte 7	Byte 8	Byte 9	Byte 10

Meaning of the frame above:

- the MSB (byte 1) indicates the z-master short address;
- the second means that this is an answer of 0x10 question (write frame);
- the third and fourth bytes indicate the start RAM address of writing operation;
- the fifth and sixth bytes indicate the number of written registers;
- the seventh and eighth bytes represent the content of the writing frame;
- the last two bytes are the CRC-16 of the whole frame.

The parameters which can be written are:

Parameter	Modbus address	EEPROM address
MODBUS ADDRESS	44000 MSB	0X14
MAX LAST NET ACTIVITY	44000 LSB	0X15
BINDING MODE	44001 MSB	0X11
TX-POWER	44001 LSB	0X0B

EEPROM CONFIGURATION

Location	Parameter	Description	Default value
0x00	MAC address	MAC module address	Optoi IAB§§
0x06	Short address	Module ID	
0x08	App_number	Application ID # in a channel (0-255)	134
0x09	Net_identifier	Net ID # in a channel (0-255)	125
0x0B	Tx power		254 (-1dBm)
0x10	Debug enabled	Disabled	0
0x11	Binding mode	Automatic	1
0x14	Modbus address	Modbus address	0x01
0x15	Max last net activity	Time after which OIS10 restarts itself if no activity is present [minutes]	15

§§ Every product is marked with an unique address, for more details see IEEE 802 MAC address

MECHANICAL DIMENSIONS

Units=mm Mechanical tolerance=+/-0.2mm

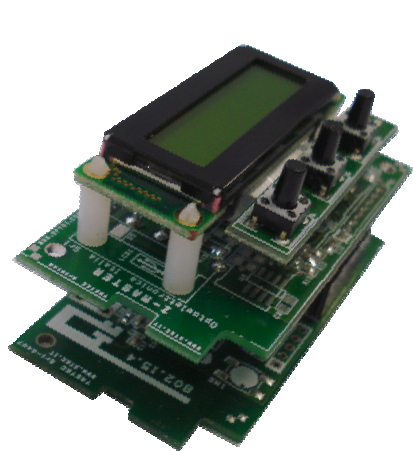
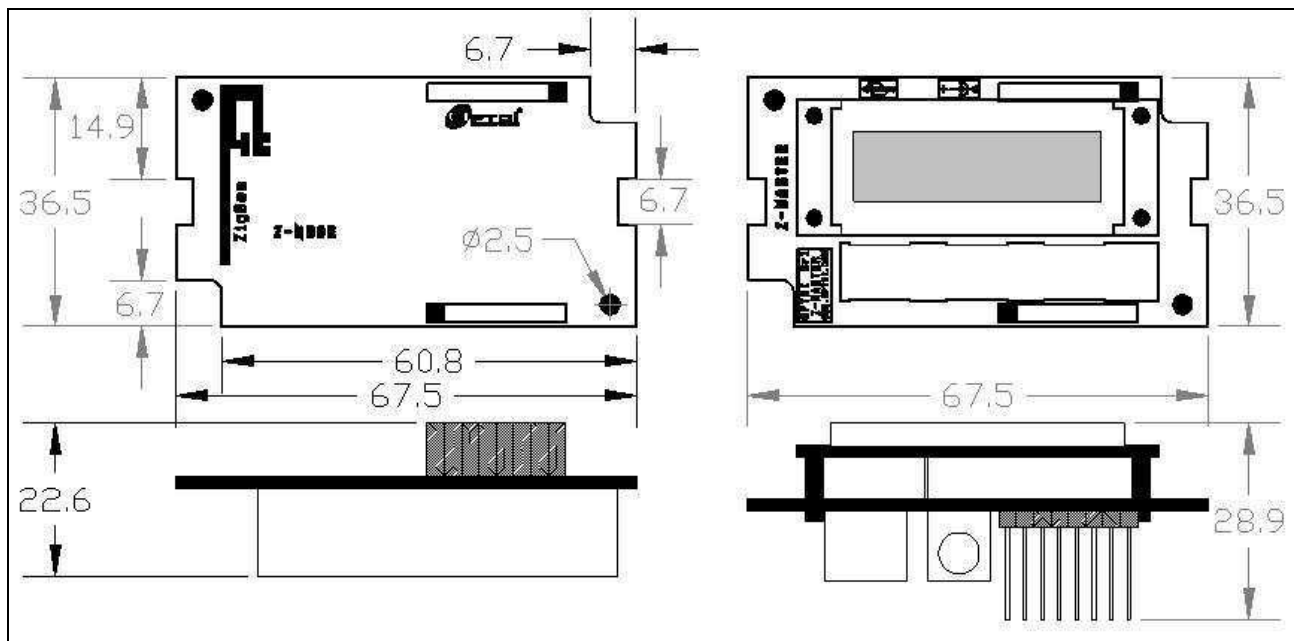

USB connector

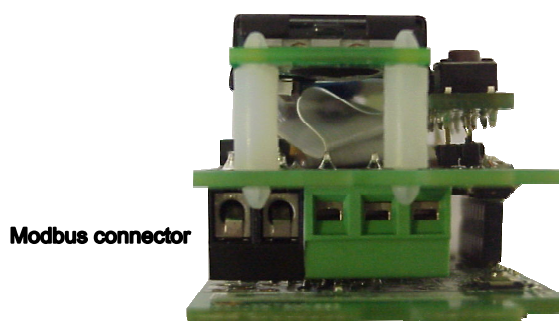

Modbus connector

Figure 3 – Z-master’s configuration

Detailed Description

The z-slave OIS9 is a network element named also RFD. In the network it is just capable of talking; it talks only to a coordinator, in specific its coordinator. The object has few memory resources and it do not stores data. The only stored information are its parameters. The z-slaves transmits on a specific radio channel of 802.15.4 standard, over 2.4 GHz and it cannot relay data from other devices.

The node has a 64 bit unique address, the lowest part (16 bit) is the network address.

Standard 802.15.4

The stack is compliant to 802.15.4 standard, which is based on the OSI (Open Systems Interconnection) seven layers model, but specifies the two lower levels: the physical layer (PHY) and the medium access control sub-layer (MAC). The network and the application layers are Optoi proprietary. The responsibilities of the network layer (NWK) are the following:

- starting a network, the ability to successfully establish a new network;
- joining and leaving a network, the ability to gain membership (join) or relinquish membership (leave) a network;
- configuring a new device, the ability to sufficiently configure the stack for operation as required;
- addressing, the ability of a coordinator to assign addresses to devices joining the network.
- synchronization within a network, the ability for a device to achieve synchronization with another device either through tracking beacons or by polling;
- security, applying security to outgoing frames and removing security to terminating frames;
- routing: routing frames to their intended destinations.

The application layer (APS) has the responsibility of:

- maintaining tables for binding;
- initiating and responding to binding requests;
- establishing a secure relationship between network devices.

Binding Procedure

The first initialization (also called binding) configures the network: it consists in the registration of each sensor in the network, assigning a unique ID code to the component. The binding is the logical link (“virtual wire”) between z-master and z-slave. It is assigned one time only, in the first phase of net configuration. For a binding procedure these steps must be followed:

- switch on the z-master that controls the network;
- hold down the button on the z-slave that must be binded;
- connect the batteries on z-slave and wait until the green led blinks;
- the z-master will recognize the new device that wants belong to the network, showing the message “binding request” on its LCD;
- just press OK letting the z-slave join the network, if manual binding is selected.

The binding procedure can also be set to automatic (z-master menu), in this case pay attention because all the

z-slaves requests will be satisfied automatically, until the z-master addressing space will be full.

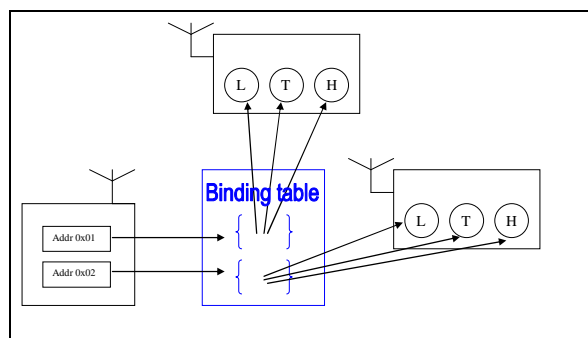

Figure 4 – binding procedure

Channels

The available channels in the band 2.4GHz are 16, from 11th to 26th. Regarding the binding procedure it is possible to let the z-slave search in some channels only. The start search and stop search channels are set at the EEPROM locations 0x12 (start) and 0x13 (stop). The permitted values are from 0x0B (ch 11) to 0x1A (ch 26). By default the node searches in the whole band: the start channel is set to 11 and the stop channel to 26. The IEEE 802.15.4 has two PHY layers, that operate at 868/915MHz and 2.4GHz. This last frequency is used worldwide and this product is tuned on this band.

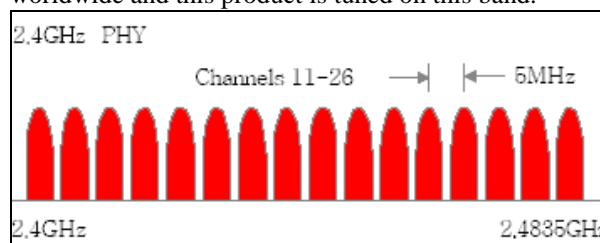

Figure 5 – frequency channels

Joining/leaving the network

Even if the node leaves the network, z-master maintains the information regarding this node. After the z-slave is binded, it can leave or join the network in every moment; it is always recognized by the coordinator. This case could happened for instance when the batteries are low, or when the signal isn't good enough; the node becomes inactive and cannot transmit its values . A particularly attention must be paid if some z-slaves have the same network address. The z-master will recognize both z-slaves and the values will be overwritten every time at the address space reserved.

Data transmission-wake-up time

The data of the three sensors is transmitted every specified time interval. This value is user selectable (see table EEPROM areas) and it is specified at the address 0x0A (wake-up and send data) in multiple of 8s.

In order to improve the module's performances, it is also possible to set another time interval, value specified at the address 0x0C (wake-up alarm and send data). This data represents the sending time interval in case of one ore more sensor's values exceed the threshold parameters (see thresholds EEPROM area).

If z-master doesn't reply to the z-slave message, z-slave

transmits again for maximum 5 times, after which the module resets itself and searches again a network. If it doesn't find any nets, it goes to sleep.

Data format

The message from the slave to the master is built in this form:

Node ID	TEMP	HUM	LUM	BAT	CRC
RFD addr.	tempera- ture level	humidity level	luminosity level	battery level	CRC code

Z-slave waits the master response and then goes to sleep.

When it wakes up again (every 8s) z-slave tests the switch value and if pressed, waits to be released. Both leds will blink at high frequency. When the switch will be released the node will reset itself.

If the switch is not pressed and it is time to send data, the z-slave transmits the string; if there are no data to transmit, the device goes to sleep again. The transmission rate can be only multiple of 8s (wake-up time).

At the location 0x0F the user can set the time in which the z-slave is trying to search the network again (default every 10 minutes).

Sleepmode

The z-slave goes into sleep mode after receiving the command "go to sleep" by z-master.

The second reason is when the z-slave doesn't find any network (because the master is switched off or there is no field).

In the first case the wake-up time is 8 seconds, in the second case it is set into the EEPROM area at the address 0x0F.

Transmission power

The transmission power is user selectable and the value must be set into the EEPROM at the address 0x0B. The default value is the maximum value, 0dBm. A lower value means less module power consumption. See the specific table to set the desired value.

Sensors

The OIS6 sensors board is build up with three fundamental sensors: temperature, relative humidity and luminosity.

The sensors are very accurate, they in are factory calibrated and the drifts are controlled by a microprocessor unit. The temperature accuracy is 1°C full range, the humidity is 1% R.H. (in the range 30-70% R.H.) and the luminosity is 15 lux full range.††

The humidity degree of accuracy is obtained first with a initial calibration (in factory) and second thanks to an internal temperature compensation during operation. The recovery time after condensation (90% to 10% R.H.) is less than 10s.

The responsivity of the luminosity sensor is centred on the human eye peak responsivity; the output is internally filtered, in order to achieve a noise rejection to 50Hz and 100Hz. The response of this sensor is reset to zero at wavelengths > 700nm, so that infrared radiations emitted by lamps are also rejected.

†† These values are not valid if the sensor board is changed without module calibration

Accuracy and precision

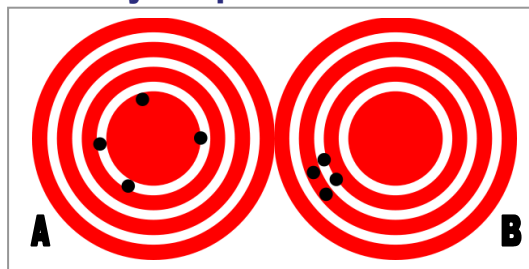

Figure 6 – accurate (A) and precise (B) measurement

Accuracy is the degree of truthfulness in a measurement. Repeated measurements are compared to arrows that are fired at a target. Accuracy describes the closeness of arrows to the bulls eye at the target center. Arrows that strike closer to the bulls eye are considered more accurate. The closer a system's measurements to the accepted value, the more accurate the system is considered to be. Precision is the degree of reproducibility of a measure. Precision is the size of the cluster one would expect if this were repeated many times under the same conditions. When all arrows are grouped tightly together, the cluster is considered precise since they all struck close to the same spot, if not necessarily near the bull's-eye.

Network

The allowed network type is a star network. Each coordinator is able to manage up to 19 z-slaves. If more elements are needed it is possible to build a Modbus network. Each z-sensor is linked to its coordinator only (binding) and it cannot interfere with the other elements. In order to avoid undesired interferences it is suggested to operate in different channels for every WSN. In Figure 7 a multiple WSN can be observed. In this case it is necessary to have a master Modbus, which could be a PC for example. The master Modbus must poll every z-master in order to avoid collisions. The z-masters send the data only if polled. Each z-master is the coordinator of its WSN. The master Modbus is needed to coordinate the multiple system.

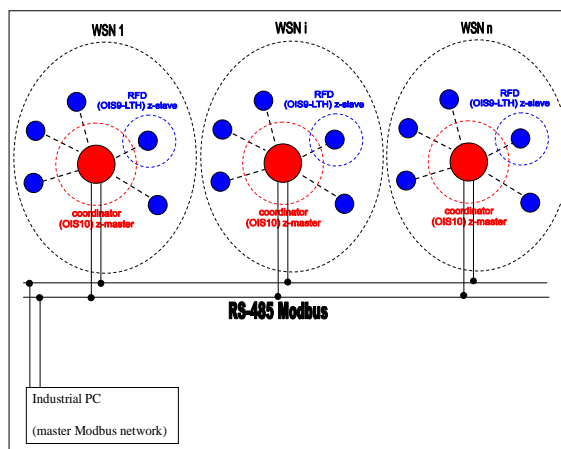

Figure 7 – multiple WSN

CRC-16 calculation

The CRC-16 calculation of a frame is explained as follows:

1. Load into a 16-bit register the value 0xFFFF. This register is called CRC-reg.
2. Extract from the sending frame the first byte (first 8 bit) and do a XOR operation with the 8 least significant bits of the CRC-reg. Put the result again into CRC-reg.
3. Shift CRC-reg 1 bit to the left, inserting a 0 into the most significant bit.

Examine the least significant bit of this register.

4. If it is “0” then repeat point number 3, else calculate the XOR between CRC-reg and the constant value 0xA001; save the result into CRC-reg.
5. Repeat steps 3 and 4 until 8 shifts have been made. Once completed it has been processed 8 bytes.
6. Repeat points from 2 to 5 eight times. In case of the message size isn’t 16 byte, queue 0x00 until the length becomes 16 byte.
7. Exchange MSB and LSB of CRC-reg.

REGULATORY COMPLIANCE TABLE

Generic normative	Description	Level
ETSI EN 301 489-17 V1.2.1 (2002)	Electromagnetic compatibility and Radio spectrum Matters (ERM) EMC standard for radio equipment and services Part 17 Specific conditions for 2.4GHz	-
ETSI EN 301 489-1 V1.6.1 (2005)	Electromagnetic compatibility and Radio spectrum Matters (ERM) EMC standard for radio equipment and services. Part1 Common technical requirements	-
ETSI EN 300 328 V1.7.1 (2006-10)	Electromagnetic compatibility and Radio spectrum Matters (ERM); Wide-band transmission systems; Data transmission equipment operating in the 2,4GHz ISM band and using wide band modulation techniques; Harmonized EN covering essential requirements under article 3.2 of the R&TTE Directive	-
EN 61000-6-1 (2007)	Electromagnetic compatibility (EMC). Generic standards. Immunity for residential, commercial and light-industrial environments	-
EN 61000-6-3 (2007)	Electromagnetic compatibility (EMC). Generic standards. Emission standard for residential, commercial and light-industrial environments	-
EN 60950-1 (2006)	Information technology equipment. Safety. General requirements	-

Application notes



Connecting the z-master

The z-master is composed in two parts. The easier version of master point is simply a z-node (tx and rx board) plus a master (USB or MODBUS) board (OIS7 + OIS8 = OIS10).

The two items are plugged together with standard strip connectors.

Install the USB serial port drivers into your PC (www.ftdi.com) if you have the OIS10-USB model.

Simply connect the z-master to the PC via USB port and choose the option “search the best driver for this application”.

The OS will recognize the device as a general purpose USB device.

Install the software “Domotic WSN” and run the application. If there are z-slaves already connected to the master they are recognized by the software, otherwise connect the z-slaves following the procedure below.

Connecting the z-slaves

The z-slave is composed in two parts. The first version of z-slave is the OIS9-LTH: this is a multi sensor board (luminosity, temperature and relative humidity) combined with a z-node (OIS6 + OIS7 = OIS9).

The sensor’s values are transmitted every time slot (this parameter can be modified) and after transmission the module goes to sleep.

For the first time installing a network a “binding” procedure is necessary: this procedure associates the slaves to a master. Only the binded slave can talk to the master into its net; the master stores the slaves ID for other times.

The binding procedure is described below:

- press the switch on the z-node and connect the power supply (batteries); after that release the switch;
- the master display should show a message “binding request”;
- press the switch correspondent on the master to accept the binding request;

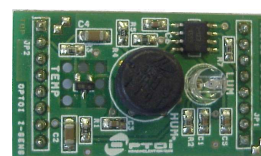

- the slave is stored into the master memory as authorized slave.

Demo Software

Launch the file “Domotic WSN”. The program searches for the master connected and displays either the connection or the number of slaves connected to the master. A plant (jpeg format) can be loaded from the panel and the user can place the sensors in the right position on the map. The sensors can be added or removed from the main panel. Pushing the run button an acquisition begins. A graph can visualize the trend of the physical values VS the time. The sensor’s data can be stored in a unique file or in split files for each node.



Low power detecting systems	Outdoor Air Quality	Industrial remote monitoring
Low cost and flexible transmission	Process control	Wireless Sensors Networks
Energy conservation	Green building systems	Indoor Air Quality

Safety indoor monitoring

Optoi-Bee OIS9-LTH can be used as building safety monitoring. The wireless power supply and data transmission of the z-slave can avoid wire connection problems.

The most indoor wellness parameters like temperature, luminosity level and relative humidity can be controlled directly by a master node. The z-master node can be connected to a PC (OIS10-USB), to another bus network (OIS10-MODBUS) or simply operate as data logger, in order to record data, control or activate alarms, switches, relay...

The wellness and security parameters in disable and old-age people houses often needs to be controlled by a supervisory sensor network. This kind of network is easy to install and to use, compared to previous custom installations of home master remotes.

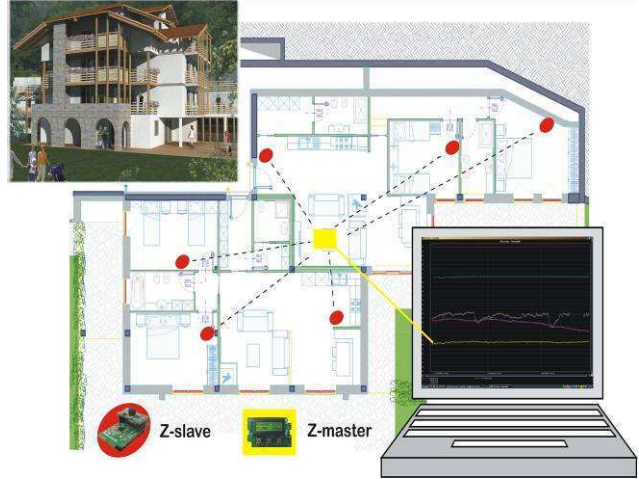

Outdoor monitoring

OIS9 can also be used in outdoor applications, in order to measure the main parameters like air quality or outdoor wellness parameters. The continuous monitoring of essential parameters in streets, cities, quarters is very important for the human wellness and safety. The sensor networks in general can also help to monitor bridge conditions, streets conditions, real-time tracking of agriculture environments.

The Kyoto protocol observance means more and frequent ambient parameters control. Wireless networks could be built by the cities that want to examine the ambient situation around.

Production parameters control

The advantage of using wireless sensors in industrial field are the lower installation costs compared to wired systems.

The industrial waste needs often to be monitored, either to prevent pollution, or to increase the system efficiency. This is compliant with Kyoto protocol and with the new industrials politics.

Energy saving

With the increased cost of energy and demands by corporate boards to “go green”, there has never been a better time to consider the value proposition of an enterprise energy management strategy for buildings. It is necessary to achieve sustainable and green buildings. Moreover the cut of energy costs like lighting, heating, ventilation, cooling can be realized trough more efficient energy management and control.

