

General Description

Optoi **OIAC2** is an absolute inclinometer, based on MEMS (micro electro mechanical systems) technology 3-Axis accelerometer. The device is able to sense tilt angles over ± 30 degrees range in the pitch and roll axis. **OIAC2** belongs to a new category of inclinometers, that are compact, low cost, rugged, fast and very flexible. The accuracy in both angles is ± 0.5 deg in the whole angle and temperature ranges.

OIAC2 detects mathematically the tilt angles, based on all sensed accelerations (gravity) applied to the inclinometer along the X and Y axis. The signals are then filtered using an analog second order low-pass filter with cut-off frequency of 20Hz (fixed filter) and a user programmable digital filter (variable filter). The sum of these filters produces a formidable noise rejection (to vibrations for example) on the measured angles. The digital filter is a moving average filter, which is programmable from 1 to 1000 samples. The noise is reduced increasing the number of samples on which the signal is averaged and also the measured angle is less sensible to the vibration. However a larger number of samples coincides with a longer response time.

Applications

Construction Equipments
Solar Farms
Warehouse Automation
Agricultural Machines
Building automation
Mining Equipments
Car and Truck Overturn Alarm Systems

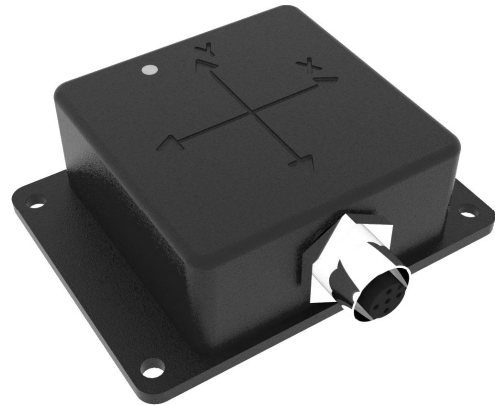

Features

- Accuracy of ± 0.5 deg in $\pm 30^\circ$ range, both axis, whole temperature range
- Very fast sampling rate (up to 550 S/s)
- CANopen bus interface (protocol conform to CANopen Draft Standard 301 v4.02)
- ± 30 deg capability in pitch and roll axis
- Wide (9-36V) power supply range
- MEMS Technology
- Anti-Vibration flexible filter
- Small dimension 30(H)x70(L)x88(W) mm
- Reduced temperature drift
- Field Programmable
- Factory Calibrated
- Customization available on request

Pin Functions

	Name	Function
1	SHIELD	Optional CAN shield
2	VCC	Power Supply
3	GND	Ground
4	Data AH	CAN_H bus line (dominant high)
5	Data BL	CAN_L bus line (dominant low)

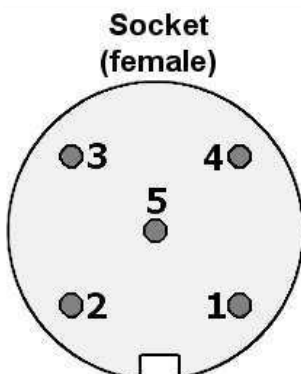

Ordering Information

OIAC2 ± 30 deg CAN OPEN 301 4.02 protocol

OIAC2

ABSOLUTE MAXIMUM RATINGS

Symbol	Parameter	Min	Max	Unit
T _A	Operating Temperature Range	-30	60	°C
V _{CC}	Supply Voltage Range (dc voltage)	9	36	V
T _S	Storage Temperature	-40	100	°C

Stresses beyond those listed under "Absolute Maximum Ratings" may cause permanent damage to the device. These are stress ratings only, and functional operation of the device at these or any other conditions beyond those indicated in the operational sections of the specifications is not implied. Exposure to absolute maximum rated conditions for extended periods may affect device reliability.

ELECTRICAL CHARACTERISTICS

T_A = 25°C, unless otherwise noted.

Symbol	Parameter	Conditions	Min	Typ	Max	Unit
T _A	Operating Temperature Range		-30		60	°C
V _{CC}	Supply Voltage Range		9	12/24	36	V
I _{CC}	Current consumption		60	65	70	mA
R	Resolution	-30°C < T _A < +60°C		0.1		deg
A	Accuracy ²	+/-30 deg range, filter max		±0.5		deg
SR	Sample Rate			550		S/s
BR	Baud Rate		20	250	1000	Kbit/s
D	Temperature Drift			±0.008		deg/°C
S	Sampling rate	Normal operation		550		S/s

MECHANICAL CHARACTERISTICS AND DIMENSIONS

Symbol	Parameter	Conditions	Min	Typ	Max	Unit
R	Range roll		-30		+30	deg
P	Range pitch		-30		+30	deg

Units=mm Mechanical tolerance=+/-0.2mm

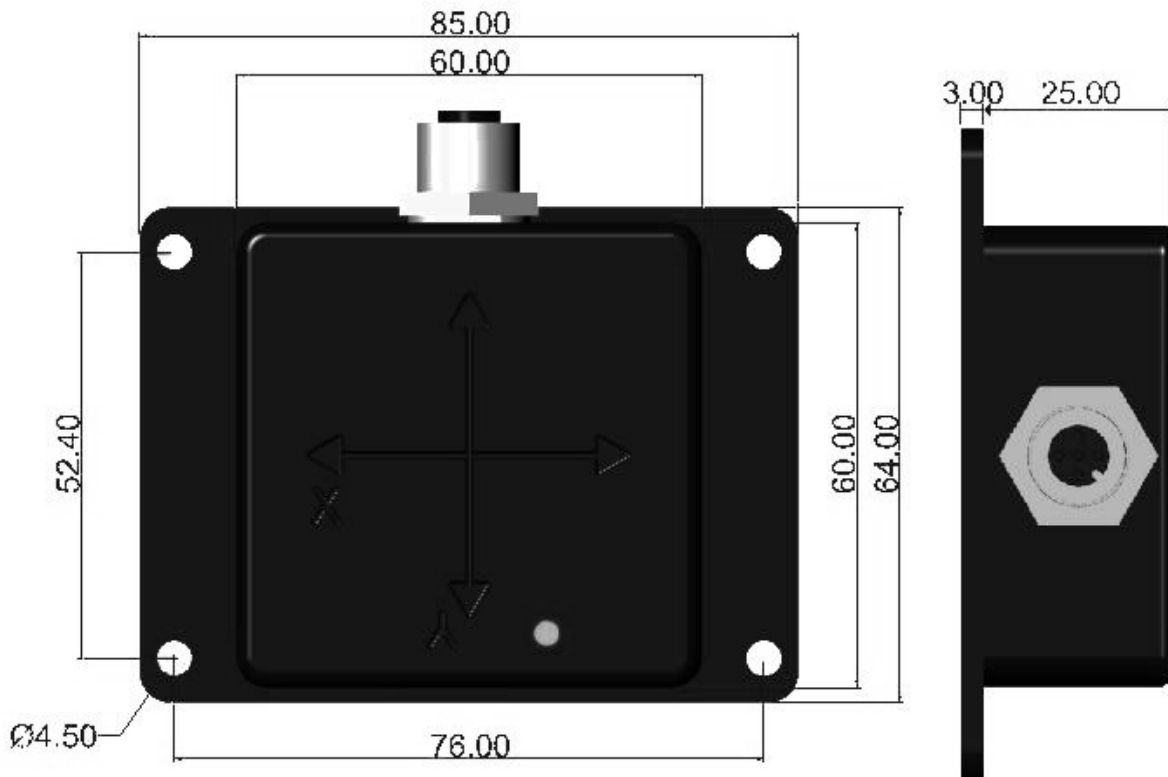

² Accuracy is intended as the maximum deviation of the measure from the real value in the whole temperature range for a fully and correctly calibrated sensor in the ±30° range

Detailed Description

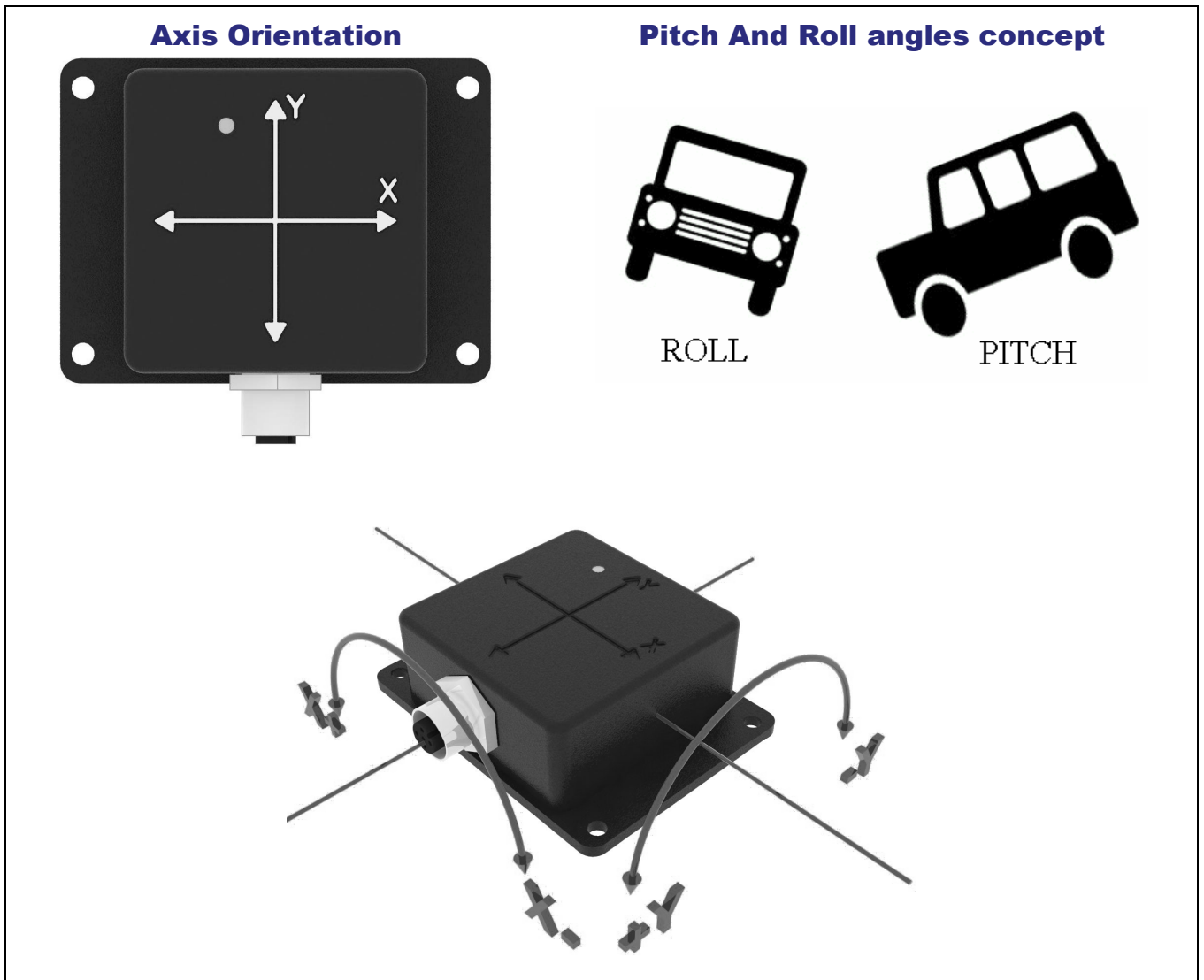

CAN bus line wiring scheme

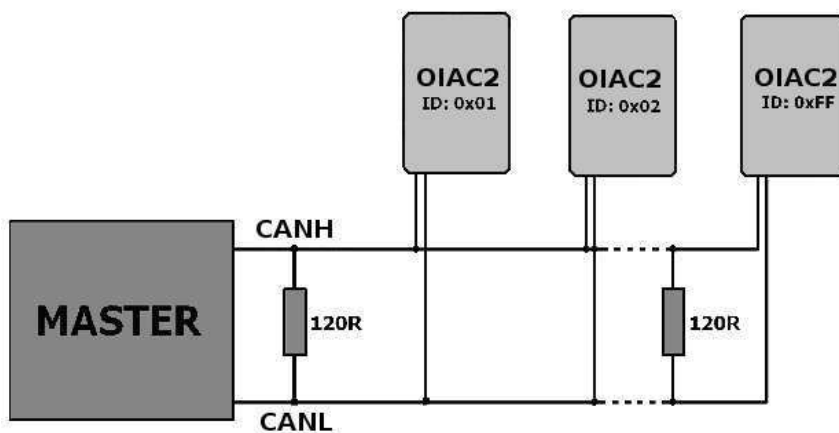

OIAC2 doesn't have any internal bus line terminator resistor, so the user must take care of this aspect, connecting the 120ohm terminator at the beginning and at the end of the bus.

Node ID and Supported Baud Rate

Any change applied at the *Node ID* and *Baud Rate* will have effect only after the node reset. The reset can be an hardware reset or also a software reset, issued with “*Reset application*” or “*Reset communication*” NMT frame. These parameters are infact saved immediately in the non volatile memory of the node, and only after reset all the COB ID’s are recalculated, according to the pre-defined connection set. It’s possible to restore the default values of *Node ID* and *Baud Rate*, writing the “*load*” string in the “*Restore default parameters*” object in the object dictionary.

Default ID	0x41
Default Baud Rate	250 kbit\s

The OIAC2 is designed to support different CAN baud rates, as referred in the CANopen Draft Standard 301. The supported baud rates are reported in the following table: its possible to set one of these values simply writing the corresponding hex value in the “*CAN baud rate*” object of the object dictionary.

Supported Baud Rates (kbit\s)	20	50	125	250	500	800	1000
--------------------------------------	----	----	-----	-----	-----	-----	------

COB identifiers

Message	Direction	COB-ID	Descriptions
NMT	RX	0x000	Network Management services: operational, pre-operational, stop, reset
Boot Up	TX	0x80 + NodeID	Boot Up (CANopen sd301 v3.0)
TX-PDO 1	TX	0x180 + NodeID	One axis mode data
TX-PDO 2	TX	0x280 + NodeID	Two axis mode data
TX-PDO 4	TX	0x480 + NodeID	Internal temperature and error register data
SDO (Client → Server)	RX	0x600 + NodeID	Access to object dictionary
SDO (Server → Client)	TX	0x580 + NodeID	Reply to SDO request
BootUp \ Heartbeat	TX	0x700 + NodeID	Boot Up (CANopen sd301 v4.x) Heartbeat: sent periodically if configured

Network management objects

During the boot-up procedure the node sends two different boot-up messages; after the node initialization is completed the device enters in the *pre-operational* state.

COB-ID	Number of Data Bytes	Byte 1	Description
0x080 + NID	0	-	Boot-up message in accord to CANopen sd301 v3.0
0x700 + NID	1	0x00	Boot-up message in accord to CANopen sd301 v4.x

Network management services uses the COB ID 0x0000, so the message can be broadcasted to all the network nodes or directly to a specific one, writing the corresponding ID in the second data byte of the NMT frame. In the first byte of the frame is specified the command code. There are several commands available: those commands are reported in the following table:

COMMAND CODE	Description
0x01	Start remote node → Enter the node's OPERATIONAL state
0x02	Stop remote node → Enter the node's STOP state
0x80	Enter node's PRE – OPERATIONAL state
0x81	Reset Node
0x82	Reset Communications

NMT frame structure:

CAN Identifier	Byte 0	Byte 1
0x0000	COMMAND	0x00 (broadcast) or Node – ID (specific node)

How to configure the OIAC2

It's possible to configure the OIAC2 using it's *object dictionary*, like all the CANopen devices. The *object dictionary* is accessible reading and writing the configuration value via CAN messages (SDO frame).

Refer to the object dictionary table located at the end of this datasheet, for the dictionary object structure (address and values).

Reading Data from Object Dictionary

To read data from object dictionary the user must send an *SDO Request Frame* to the device, specifying the address and the eventual sub-index of the desired object. OIAC2 will answer to the *SDO Request Frame* with another SDO frame, which will contain the desiderate data.

SDO Request data frame:

COB ID	Byte 0	Byte 1	Byte 2	Byte 3	Byte 4 ... Byte 7
0x600 + NID	0x40	Index LOW	Index HIGH	Sub-Index	Not used

Answer frame from OIAC2 :

COB ID	Byte 0	Byte 1	Byte 2	Byte 3	Byte 4 ... Byte 7
0x580 + NID	table below	Index LOW	Index HIGH	Sub-Index	Data (low to high bye)

Meaning of the Byte 0 in the answer frame:

Value	Data length
0x40	Any size length
0x4F	1
0x4B	2
0x43	4

Writing Data in the Object Dictionary

To write a parameter in the object dictionary the user must send an *SDO Download Request Frame* to the device, specifying the address and the eventual sub-index of the desiderate object. The length of the value sent to the OIAC2 can be 1byte, 2byte, 3byte or 4byte long. The segmented transfer for data length above 4 bytes is not supported by this device. The OIAC2 will answer to the *SDO Download Request Frame* with another SDO frame, which will contain the value corresponding to the specified address (address and eventual sub-index if needed).

SDO Download request data frame:

COB ID	Byte 0	Byte 1	Byte 2	Byte 3	Byte 4 ... Byte 7
0x600 + NID	Table below	Index LOW	Index HIGH	Sub-Index	Parameter to write

Meaning of the Byte 0 in the SDO Download request frame:

Value	Data length
0x22	Any lenght
0x2F	1 byte
0x2B	2 bytes
0x23	4 bytes

Answer frame of OIAC2 :

COB ID	Byte 0	Byte 1	Byte 2	Byte 3	Byte 4 ... Byte 7
0x580 + NID	0x60	Index LOW	Index HIGH	Sub-Index	Not used

SDO abort codes

In case of failure of a *SDO Request* or a *SDO Download Request* the OIAC2 responds with a *SDO Abort Message*, where the cause of the error is explained with an error code.

SDO Abort frame:

COB ID	Byte 0	Byte 1	Byte 2	Byte 3	Byte 4 ... Byte 7
0x600 + NID	0x80	Index LOW	Index HIGH	Sub-Index	Error code

Code	Bytes 4...7	Failure Reason
0504 0001	0x01;0x00;0x04;0x05	SDO command specifier not valid or unknown
0601 0002	0x02;0x00;0x01;0x06	Attempt to write a read only object
0602 0000	0x00;0x00;0x02;0x06	Object does not exist in the object dictionary
0604 0043	0x43;0x00;0x04;0x06	General incompatibility reason
0607 0010	0x10;0x00;0x07;0x06	Data type does not match, length of service does not match
0609 0011	0x11;0x00;0x09;0x06	Sub-index does not exist
0609 0030	0x30;0x00;0x09;0x06	Value range of parameter exceeded (only for write access)

Error register codes

The error's types are stored into the 8-bit *Error Register*. Each bit in the register is associated with a specific error in the OIAC2 working conditions, communications or OIAC2 internal error. This register is accessible by reading the object at index 0x4000 sub-index 0x0A of the dictionary. The register is also transmitted in TPDO4 frame, that contains also the device's internal temperature. An error is signaled setting to logic value "1" the corresponding bit in the error register. In a normal condition, without errors, the value of the register is 0x00.

It is possible to reset the error bits simply writing the value 0x00 in the object dictionary at the address 0x4000 sub-index 0x0A .

Bit 7	Not used
Bit 6	Device axis's not calibrated
Bit 5	CAN BUS OFF
Bit 4	CAN message lost
Bit 3	Not used
Bit 2	Not used
Bit 1	MEMS sensor fault
Bit 0	Internal temperature out of range

Heart beat producer

To enable the transmission of the heartbeat frame, a period great than zero has to be written into the object dictionary at index 0x1017 sub-index 0x00. The object is initialized by default to zero, no heartbeat transmission. Writing a value greater than zero in the producer heartbeat interval time object the heartbeat frame transmission is enabled and the device sends the following periodic message:

COB ID	Byte 0	Corresponding OIAC2 state
0x700 + NID	0x00	Boot up
	0x04	Stop condition
	0x05	Run condition
	0x75	Pre-operational condition

OIAC2 in operational mode

The OIAC2 inclination sensor is designed to operate in two different operational modes:

- Two axis ± 30 degree inclinometer (main mode)
- One axis full 360 degree inclinometer

To set the operational mode it is necessary writing the object in the dictionary at index 0x320C sub-index 0x00. By default the two axis operational mode is selected (object value 0x01).

Depending on the selected operational mode for OIAC2, different PDO frames are enabled/disabled:

MODE	PDO1	PDO2	PDO3	PDO4
One axis mode	Enabled	Disabled	Not implemented	Enabled
Two axis mode	Disabled	Enabled	Not implemented	Enabled

OIAC2 in one axis (360°) operational mode

In this mode of operation the OIAC2 must be mounted in vertical position and the user can specify a non zero offset for the angle, writing the desiderate value (two's complement) in the object at address 0x320E sub-index 0x01. During the tilt angle calculation the OIAC2 will subtract this value from the absolute tilt angle value. This offset value can be saved in the non-volatile memory sending a "save application" or "save all" command to the OIAC2.

During two axis inclinometer operational mode the transmitted PDO frames are PDO1 and PDO4.

PDO1 frame organization

COB ID	Byte 0,1	Byte 2,3	Byte 4,5	Byte 6	Byte 7
0x180 + NID	Angle value in 0.1° units (LSB first)	Sinus *1000 (LSB first)	Cosine * 1000 (LSB first)	Quadrant (1,2,3,4)	Not used

OIAC2 in two axis ($\pm 30^\circ$) operational mode

In this mode the OIAC2 must be mounted in horizontal position. Is possible to set the x and y angles offset values automatically writing the value 0x00 in the object at address 0x320E sub-index 0x02. After that the user can read the offset accessing in the dictionary at addresses 0x320D sub-index 0x09 for the X axis and sub-index 0x0A for the Y axis. These values will automatically subtracted from the measured angles. These two offset values can be saved in the non-volatile memory sending a "Save Application" or "Save All" command to the OIAC2.

PDO2 frame organization

COB ID	Byte 0,1	Byte 2,3	Byte 4,5,6,7
0x280 + NID	X angle value in 0.1° units (LSB first)	Y angle value in 0.1° units (LSB first)	Not used

PDO4 frame organization

COB ID	Byte 0	Byte 1	Byte 2,3,4,5,6,7
0x480 + NID	Internal temperature 1°C units	Error register content	Not used

TX-PDO transmission type

While CANopen specifies different transmission types, the OIAC2 implements only transmission type 0xFE (254), that corresponds to the asynchronous event-driven transmission type. This means that the PDO frames are transmitted when the value change respect to the last transmitted value.

It's possible to set also an event timer to force PDO temporized transmission, even if the value does not change. This event timer can be configured with *SDO Download Request Frame*, writing the corresponding PDO communication parameters object in the dictionary. These address are 0x01800 sub-index 0x05 for PDO1, 0x1801 sub-index 0x05 for PDO2 and 0x1803 sub-index 0x05 for PDO4. The default value for all the event timers is 0x00: this means that the event timer is deactivated and PDO will be transmitted only if the measured value changes from the last transmission. The event timers can be set with value multiple of 1ms from a minimum of 1ms to a maximum of 65535ms.

It's also possible to set an inhibit timer, that can be used to prevent CAN bus flooding due to continuous frequent transmissions. The inhibit time can be configured with *SDO Download Request Frame*, writing the corresponding PDO communication parameters object in the dictionary. These address are 0x1800 sub-index 0x03 for PDO1, 0x1801 sub-index 0x03 for PDO2 and 0x1803 sub-index 0x03 for PDO4. Default value is 0, but the implementation imposes a minimum delay of 10ms: this means that, even if the inhibit time is shorter than 10ms, the device will not send two PDO frame within less than 10 ms. The value can be set multiple of 100us, from a minimum of 10ms to a maximum of 6553ms.

OIAC2 Filters

The OIAC2 has two filters, in order to reduce the noise of the measure: the first is an active 2nd order analogical filter, with a cut off frequency of 25Hz (fixed and hardware), the second is a software filter, which is user selectable. The noise reduction is typically necessary when the environment is vibrating. The OIAC2 implements a moving average filter in order to cut the noise and get a stable value. The optimal number of sample that must be averaged to achieve a more stable measure depends on the application and is a of result of a trade off between measure's stability and sensor's reaction time. This filter parameter is in the object dictionary at index 0x3210 sub-index 0x00. Default value is 0x64 (100 samples). The same parameter affects the angle in one-axis mode and two-axis mode. If the value is set to 0x01, the samples aren't filtered at all (average over one single sample).

Frequency response of the filter is strictly correlated to the number of averaged samples and the sample rate, as shown in the formula and in the chart here below. OIAC2 has a sample rate of 550 samples for second in normal run condition, which means no frame transmitted or received, no non-volatile memory writing. Non-volatile memory writing can heavily slow down the sample rate, due to the time that is necessary to write the data in the memory.

$$H[f] = \frac{\sin(\pi \times f \times M)}{M \times \sin(\pi \times f)}$$

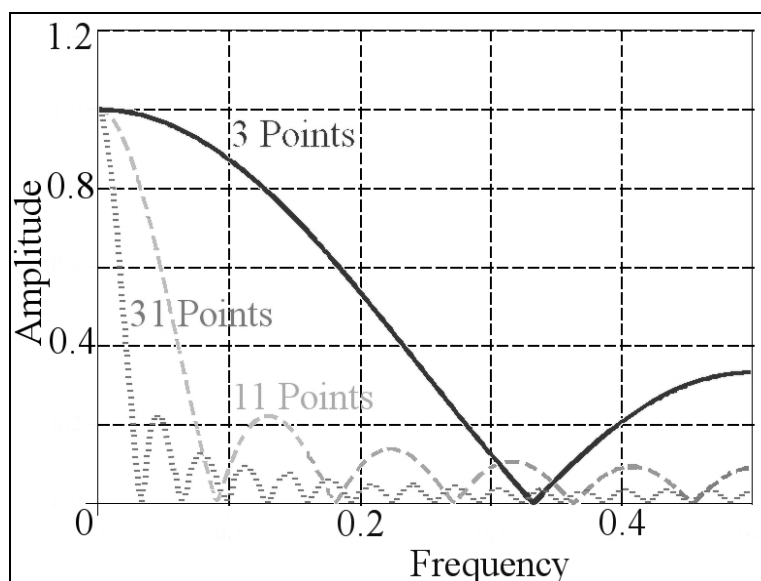

Figure 1 – software filter response in frequency domain

Where frequency is expressed in radians per sample, the sampling rate is 550.

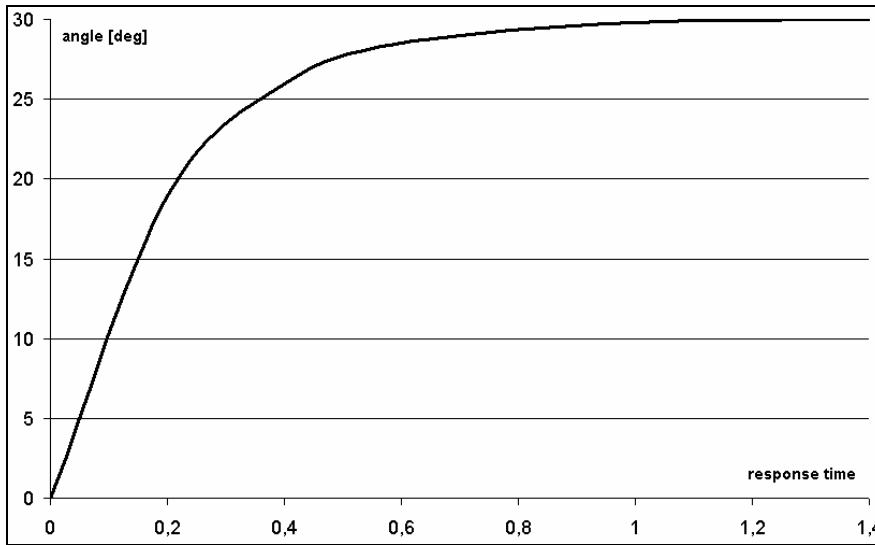

Figure 2 – step response in time domain with 550 samples filter

The damping time (or response time) can be calculated dividing the number of samples averaged per reported position by 1.82 milliseconds (sampling time).

$$\# \text{ samples} = \frac{T_d}{T_s} \text{ where } T_d \text{ is the damping time and } T_s \text{ is the sampling time (fixed at 1.82ms)}$$

Example: if the user wants to have a damping time of 1second (see figure above), the number of samples which must be set into the filter is: $1000/1.82 = 550$ samples.

OIAC2							
Index	Sub-index	Parameter description	Data Type	Access	Default value	Range	Store
1000h	0	Device type (device profile 410, two axes)	UNS32	const.	0		
1001h	0	Error register	UNS8	RO	0		
1010h	Save parameters						
	0	Largest supported sub-index	UNS8	RO	4		
	1	Save ALL parameters ("save" = 0x73,0x61,0x76,0x65h)	UNS32	RW	1		
	2	Save COMMUNICATION parameters ("save" = 0x73,0x61,0x76,0x65h)	UNS32	RW	1		
	3	Save APPLICATION parameters ("save" = 0x73,0x61,0x76,0x65h)	UNS32	RW	1		
	4	Save CALIBRATION parameters ("save" = 0x73,0x61,0x76,0x65h)			1		
1011h	Restore default parameters						
	0	Largest supported sub-index	UNS8	RO	4		
	1	Reload ALL DEFAULT parameters ("load" = 0x6C,0x6F,0x61,0x65)	UNS32	RW	1		
	2	Reload COMMUNICATION parameters ("load" = 0x6C,0x6F,0x61,0x65)	UNS32	RW	1		
	3	Reload APPLICATION parameters ("load" = 0x6C,0x6F,0x61,0x65)	UNS32	RW	1		
	4	Reload NID and BAUD RATE parameters ("load" = 0x6C,0x6F,0x61,0x65)	UNS32	RW	1		
1017h	0	Producer Heartbeat interval time [multiple of 1ms, 0 = disabled]	UNS16	RW	0	0-65535	Type 1
1018h	Identity Object						
	0	Largest supported sub-index	UNS8	RO	4		
	1	Vendor ID	UNS32	RO	N.D.		
	2	Product code	UNS32	RO	{device dep.}		
	3	Revision number	UNS32	RO	{device dep.}		
	4	Serial number	UNS32	RO	{device dep.}		
1800h	Transmit PDO1 communication parameters						
	0	Largest supported sub-index	UNS8	RO	5		
	1	COB ID	UNS32	RO	0x40000180h + NID		
	2	Transmission type [synchronous, manufacturer specific]	UNS8	RO	FE h		
	3	Inhibit time between two TPDO object [multiple of 100us]	UNS16	RW	0		Type 1
	4	Reserved	UNS8	RO	0		
	5	Event timer for cyclical transmission [multiple of 1ms, 0 = disabled]	UNS16	RW	0		Type 1
1801h	Transmit PDO2 communication parameters						
	0	Largest supported sub-index	UNS8	RO	5		
	1	COB ID	UNS32	RO	0x40000280h + NID		
	2	Transmission type [synchronous, manufacturer specific]	UNS8	RO	FE h		
	3	Inhibit time between two TPDO object [multiple of 100us]	UNS16	RW	0		Type 1
	4	Reserved	UNS8	RO	0		
	5	Event timer for cyclical transmission [multiple of 1ms, 0 = disabled]	UNS16	RW	0		Type 1
1803h	Transmit PDO4 communication parameters						
	0	Largest supported sub-index	UNS8	RO	5		
	1	COB ID	UNS32	RO	0x40000480h + NID		
	2	Transmission type [synchronous, manufacturer specific]	UNS8	RO	FE h		
	3	Inhibit time between two TPDO object [multiple of 100us]	UNS16	RW	0		Type 1
	4	Reserved	UNS8	RO	0		
	5	Event timer for cyclical transmission [multiple of 1ms, 0 = disabled]	UNS16	RW	0		Type 1
1A00h	Transmit PDO1 mapping parameters (fixed mapping)						
	0	Largest supported sub-index	UNS8	RO	4		
	1	Mapping: angle (Maps 4000/01, 16bit)	UNS32	RO	0x40000110		
	2	Mapping: angle sinus (Maps 4000/04, 16bit)	UNS32	RO	0x40000410		
	3	Mapping: angle cosines (Maps 4000/05, 16bit)	UNS32	RO	0x40000510		
	4	Mapping: quadrant (Maps 4000/03, 8bit)	UNS32	RO	0x40000308		
1A01h	Transmit PDO2 mapping parameters (fixed mapping)						
	0	Largest supported sub-index	UNS8	RO	2		
	1	Mapping: x-angle (Maps: 4000/06, 16bit)	UNS32	RO	0x40000610		
	2	Mapping: y-angle (Maps: 4000/07, 16bit)	UNS32	RO	0x40000710		
1A03h	Transmit PDO4 mapping parameters (fixed mapping)						
	0	Largest supported sub-index	UNS8	RO	2		
	1	Mapping: temperatura (Maps: 4000/02, 8bit)	UNS32	RO	0x40000208		
	2	Mapping: error bit (Maps: 4000/0A, 8bit)	UNS32	RO	0x40000A08		
3200h	0	Node ID	UNS8	RW	0x41	1...127(7Fh)	Type 2
3201h	0	Baud Rate [kBits]	UNS16	RW	250	20...1000	Type 2
320Ch	0	Mode configuration (0 = one axis ; 1 = two axis)	UNS8	RW	1	0,1	Type 3
320Dh	Reserved for calibration and debug values						
	0	Largest supported sub-index	UNS8	RO	18		
	1	X0	UNS16	RO	...	{type dep.}	
	2	Y0	UNS16	RO	...	{type dep.}	
	3	XP	UNS16	RO	...	{type dep.}	
	4	YP	UNS16	RO	...	{type dep.}	
	5	XN	UNS16	RO	...	{type dep.}	
	6	YN	UNS16	RO	...	{type dep.}	
	7	Current X axis measured value [mV]	UNS16	RO	
	8	Current Y axis measured value [mV]	UNS16	RO	
	9	offset X in two axis mode	SIGN16	RO	0	...	
	10	offset Y in two axis mode	SIGN16	RO	0	...	

	...	not used	UNS16	RO	
	18	not used	UNS16	RO	
320Eh	Mounting calibration						
	0	Largest supported sub-index	UNS8	RO	2		
	1	Offset for one axis mode (angle in 0.1°)	SIGN16	RW	0	-3600...3600	Type 3
	2	Set angle 0,0 in two axis mode (write 0 to set x-angle and y-angle to 0)	UNS8	RW	0	...	Type 3
3210h	0	Filtered samples	UNS16	RW	100	1...1000	Type 3
3211h	0	Left / Right mounting (0: right side ; 1: left side)	UNS8	RW	0	0,1	Type 3
4000h	Output values used in TPDO mapping						
	0	Largest supported sub-index	UNS8	RO	0x0A		
	1	Angle in one axis mode (0.1deg units)	UNS16	RO	...	-3600...3600	
	2	Device internal temperature (1°C units)	SIGN16	RO	...	-127...+127	
	3	Quadrant in one axis mode	UNS8	RO	...	1...4	
	4	Sinus of angle in one axis mode	SIGN16	RO	...	0...1	
	5	Cosine of angle in one axis mode	SIGN16	RO	...	0...1	
	6	X-angle in two axis mode (0.1deg units)	SIGN16	RO	...	-30...+30	
	7	Y-angle in two axis mode (0.1deg units)	SIGN16	RO	...	-30...+30	
	8	not implemented	UNS8	RO	
	9	not implemented	UNS	RO	
	A	Error bits	UNS8	RW	

Legenda	
RO	Read only register
RW	Read/write register
Type 1	Active immediately after write. Saved in the non volatile memory with communication parameters on command.
Type 2	Saved in the non volatile memory immediately afert write. Activeonly after node reset.
Type 3	Active immediately after write. Saved in the non volatile memory with application parameters on command.

REGULATORY COMPLIANCE TABLE

Generic Normative	Description	Level
EN61000-6-3	Electromagnetic compatibility (EMC). Generic standards. Emission standard for residential, commercial and light-industrial environments	
EN61000-6-2	Electromagnetic compatibility (EMC). Generic standards. Immunity standard for industrial environments	
EN60068-2-6	Environmental testing. Sinusoidal vibration test.	
EN60068-2-27	Environmental testing. Shock test.	

Application Examples

Pitch detection



Pitch and roll detection



Alarm thresholds

