

General Description

The OIER8 is a fully integrated module, designed for applications requiring an optical reflective sensor, especially for barcode reader.

The device contains a 650nm visible LED as emitter and a photodiode as photodetector.

A specific optical system made by lenses and a shutter is used to image the active area of the emitter at a distance of 3.6 mm and to detect the reflected signal.

The photodiode generates an output current signal of several nano Amperes.

The sensor is packaged in a high profile 8 pin TO-5 metal can with glass window. The emitter and receiver chips are mounted on the base of the header, side by side. Above these active elements an aspherical lens is positioned: it is needed to focus them to the same point.

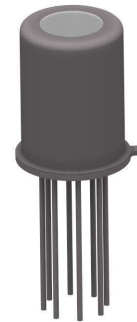

Applications

- Bar code scanning
- Pattern recognition and verification
- Object sizing
- Optical limit switching
- Textile thread counting and defect detection
- Dimensional monitoring
- Line locating

Features

- Focused emitter/receiver in single package
- 650nm visible emitter
- 0,3mm resolution
- TO-5 sealed package
- Photodiode output
- Fast response
- Output signal in photovoltaic or biased mode

Pin Functions

No.	Name	Function
1		Photodiode cathode
2		NC
3		Led cathode
4		NC
5		Led Anode
6		NC
7		NC
8		Photodiode anode

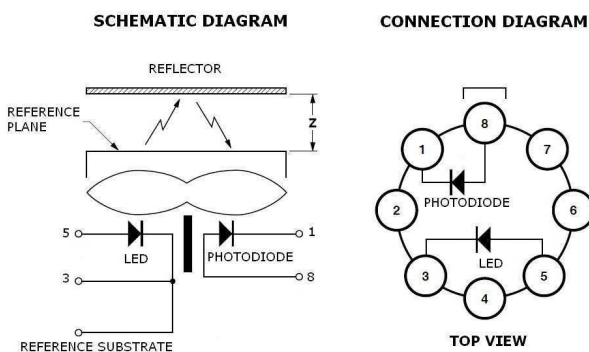

Ordering Information

OIER8-PD Standard version with output photodiode

ABSOLUTE MAXIMUM RATINGS

Symbol	Parameter	Min	Max	Unit	Note
T _A	Operating Temperature Range	-20	70	°C	
T _S	Storage Temperature	-40	80	°C	
	Lead Soldering Temperature		260 for 5 s	°C	1
I _F	Continuous LED Forward Current		20	mA	
I _{FP}	Peak LED Forward Current		50	mA	

Stresses beyond those listed under "Absolute Maximum Ratings" may cause permanent damage to the device. These are stress ratings only, and functional operation of the device at these or any other conditions beyond those indicated in the operational sections of the specifications is not implied. Exposure to absolute maximum rated conditions for extended periods may affect device reliability.

ELECTRICAL CHARACTERISTICS

T_A = 25°C, unless otherwise noted.

Symbol	Parameter	Conditions	Min	Typ	Max	Unit	Note	Figure
V _F	LED Forward voltage	I _F = 6mA		1,9	2,3	V		4
V _R	LED Reverse voltage	I _R = 10µA	12			V		
λ _P	LED Peak wavelength	I _F = 20mA	640	650	660	nm		
Z	Maximum signal point	I _F = 6mA		3.6		mm	2,3,4	2,10
I _{pr}	Photodiode reflected current (Led ON)	I _F = 6mA		500		nA	2	11
I _{ps}	Photodiode internal reflection(Led ON)	I _F = 6mA		50		nA	4	
I _d	Photodiode dark current (Led OFF)	I _F = 0		10		nA	5	
Q	Quality factor	I _F = 6mA	0.8	0.88		-	4,6	
d	System optical sensitivity	I _F = 6mA	300			µm	7	11

Notes:

- CAUTION: The thermal constraints of the optical plastic parts don't permit normal wave soldering procedures.
- If the thermal conditions stress the devices beyond its absolute maximum ratings, a damage or defocusing may be introduced, causing unwanted operations of the sensor.
- Reflected photocurrent generated by the photodiode with sensor positioned perpendicular and focused to the target. The target is a common white sheet of paper.
- The maximum signal point is obtained when the reflector is positioned at the distance Z where the image of the emitter is focused respect to the target. Distance Z is measured from the edge of the cap to the surface of the target
- The measured photocurrent I_{pt} is the sum of a component reflected from the target (I_{pr}) and a component induced by internal reflections to the sensor (I_{ps}): I_{pt} = I_{pr} + I_{ps}.
- Leakage current of the photodiode measured in the dark with led off.
- Quality factor Q shows the quality of the packaged sensor. It is the ratio between the photocurrent really reflected to the target and the total photocurrent measured by the photodiode.
- The optical sensitivity is the minimum width of the black bar on a white sheet that the sensor can detect with sensor focused.
- This is not a test parameter, but for information only.

MECHANICAL DIMENSIONS

(tolerance ±0.1mm unless otherwise noted; units:mm)

Figure 1: Mechanical dimension of TO5 package

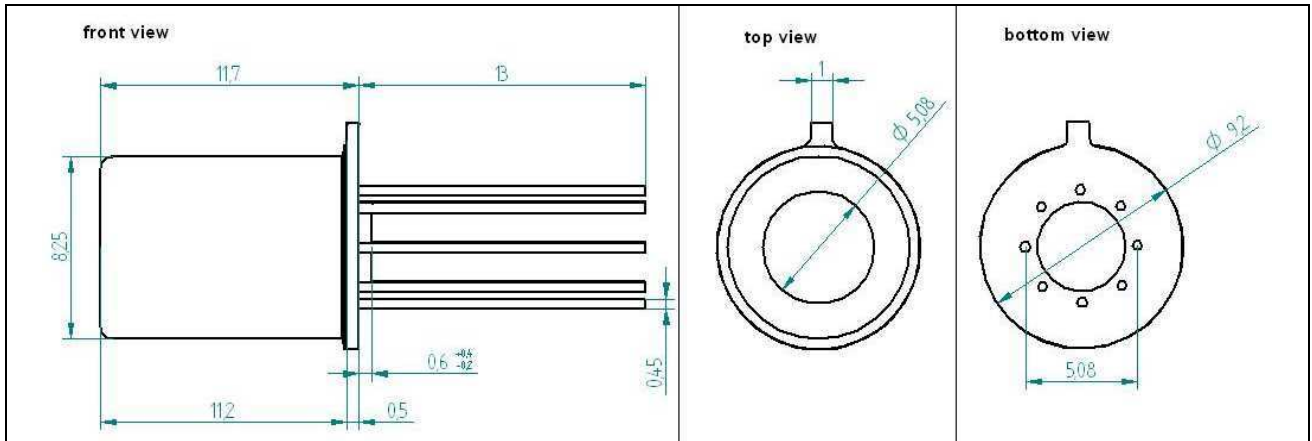

Figure 2: Photocurrent test circuit

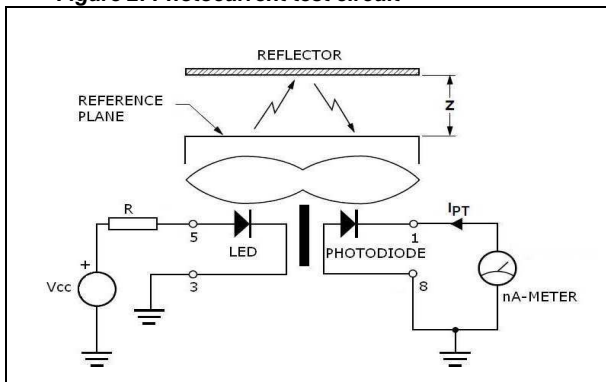
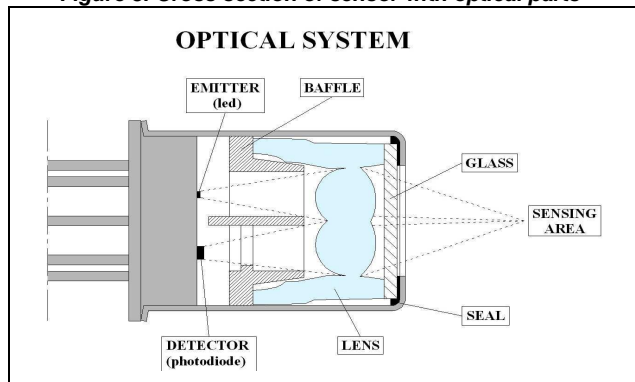

Figure 3: Cross section of sensor with optical parts



TYPICAL PERFORMANCE CURVES

Figure 4: Led forward characteristics

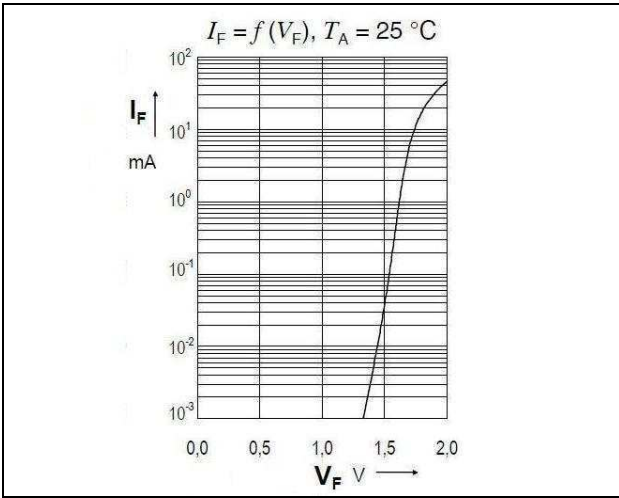

Figure 5: Radiant power of LED.

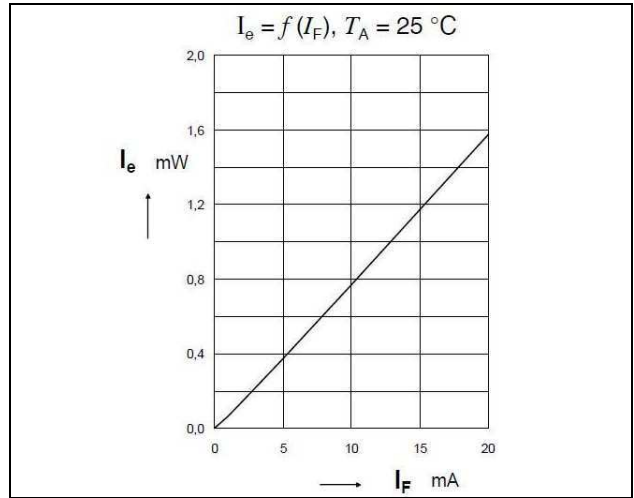

Figure 6: Photodiode forward characteristics

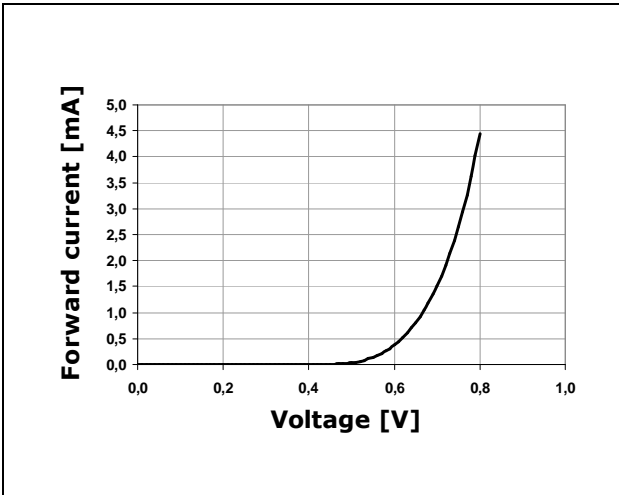

Figure 7: Photodiode reverse characteristics

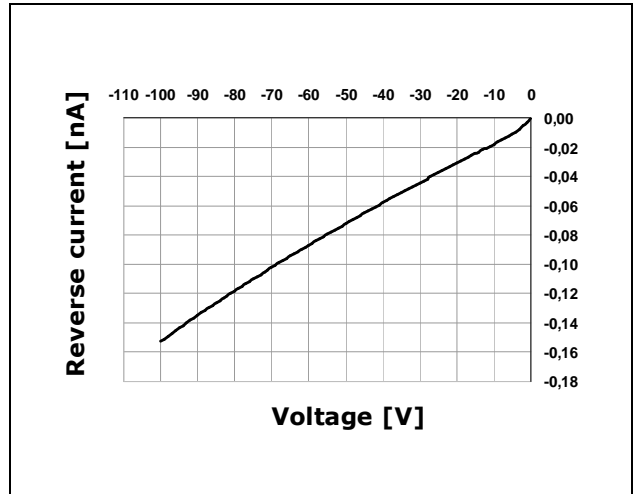

Figure 8: Photodiode spectral responsivity

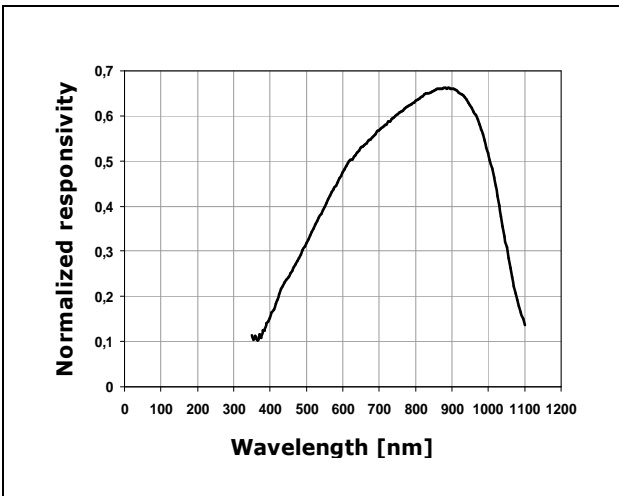

Figure 9: Temperature behaviour

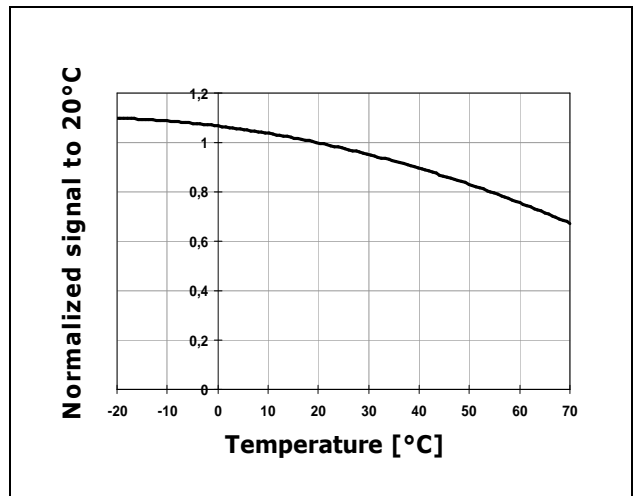

Figure 10: Normal distribution of focal length

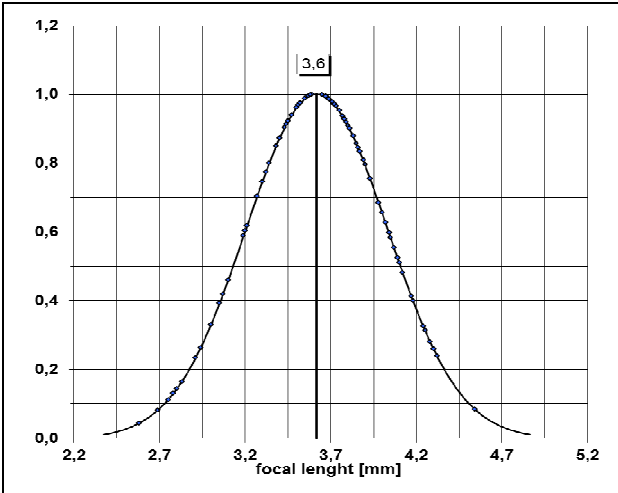
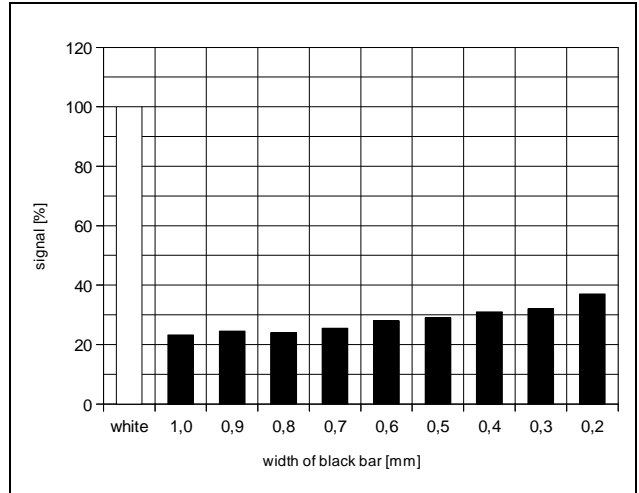

Figure 11: Current responsivity vs width of black/white bar



TYPICAL APPLICATIONS

Figure 12: typical application with current (I_{PT}) to voltage (V_O) transducer

