

General Description

The OIER3 reflective sensor consists in an infrared emitting diode and a double NPN silicon phototransistor. The components together are mounted side by side in a plastic black SMD housing. The black package avoids light reflections, noise and behaves as a barrier between led and photoreceivers.

The phototransistors respond to radiation emitted from the diode only if a reflective object surface is within the field of view of the detector.

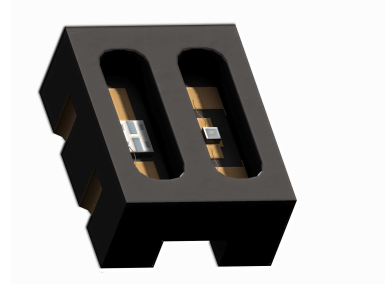

Applications

Scanning

Automated transaction systems

Metering systems

Motion control systems

Non invasive medical equipment

Low distance metering

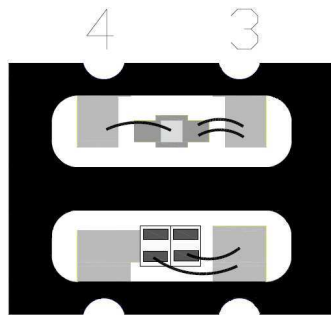

Top view

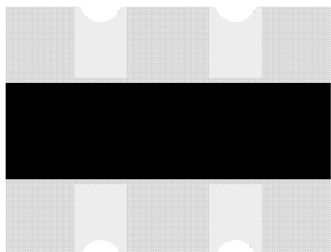

Bottom view

Features

- Unfocused for sensing diffused surface
- SMT package
- High uniformity
- Very stable measurements
- High gain phototransistor
- No contact surface sensing
- Low profile
- Low cost
- Milling on the backside for side PCB mounting

Pin Functions

No.	Name	Function
1	C	Phototransistor Collector
2	E	Phototransistor Emitter
3	A	LED Anode
4	K	LED Cathode

Ordering Information

OIER3

Reflective Sensor with Infrared LED

OIER3

ABSOLUTE MAXIMUM RATINGS

Symbol	Parameter	Min	Max	Unit
T_A	Operating Temperature Range	-25	85	°C
T_s	Storage temperature	-40	85	°C
T_{sol}	Lead temperature (solder) s		270	°C
Emitter				
I_F	Continuous forward current		50	mA
V_r	Reverse voltage		4	V
Receiver				
V_{CE0}	Collector-emitter voltage		30	V
P_d	Power dissipation		100	mW
I_c	Collector DC current		30	mA

Stresses beyond those listed under "Absolute Maximum Ratings" may cause permanent damage to the device. These are stress ratings only, and functional operation of the device at these or any other conditions beyond those indicated in the operational sections of the specifications is not implied. Exposure to absolute maximum rated conditions for extended periods may affect device reliability.

ELECTRICAL/OPTICAL CHARACTERISTICS

$T_A = 25^\circ\text{C}$ unless otherwise noted.

Symbol	Parameter	Conditions	Min	Typ	Max	Unit
Emitter						
V_F	Forward voltage	$I_F=10\mu\text{A}$		1.1		V
		$I_F=20\text{mA}$		1.5	1.7	V
λ_p	Peak wavelength	$I_F=20\text{mA}$		875		nm
$\Delta\lambda$	Spectral bandwidth at 50%	$I_F=20\text{mA}$		45		nm
Receiver						
I_{CE0}	Collector dark current	$V_{CE}=10\text{V}$		10	100	nA
$V_{(BR)CE0}$	Collector-emitter breakdown voltage		50			V
T_r	Rise time	$R_l=1\text{k}\Omega$ $V_{CE}=5\text{V}$ $I_c=1\text{mA}$		10		μs
T_f	Fall time	$R_l=1\text{k}\Omega$ $V_{CE}=5\text{V}$ $I_c=1\text{mA}$		11		μs
H_{fe}	Phototransistor's gain		500	750	1000	
Coupled						
I_c	Collector current (reflective surface @ $D=1\text{mm}$)	$V_{CE}=5\text{V}$ $I_F=20\text{mA}$	0.5	1		mA
V_{Cesat}	Collector-emitter saturation voltage	$I_F=20\text{mA}$ $V_{CE}=5\text{V}$ $D=1\text{mm}$			0.3	V
D	Optimal distance to reflective surface†			1.1		Mm

MECHANICAL CHARACTERISTICS

Unit: mm Tolerance: ± 0.2 mm

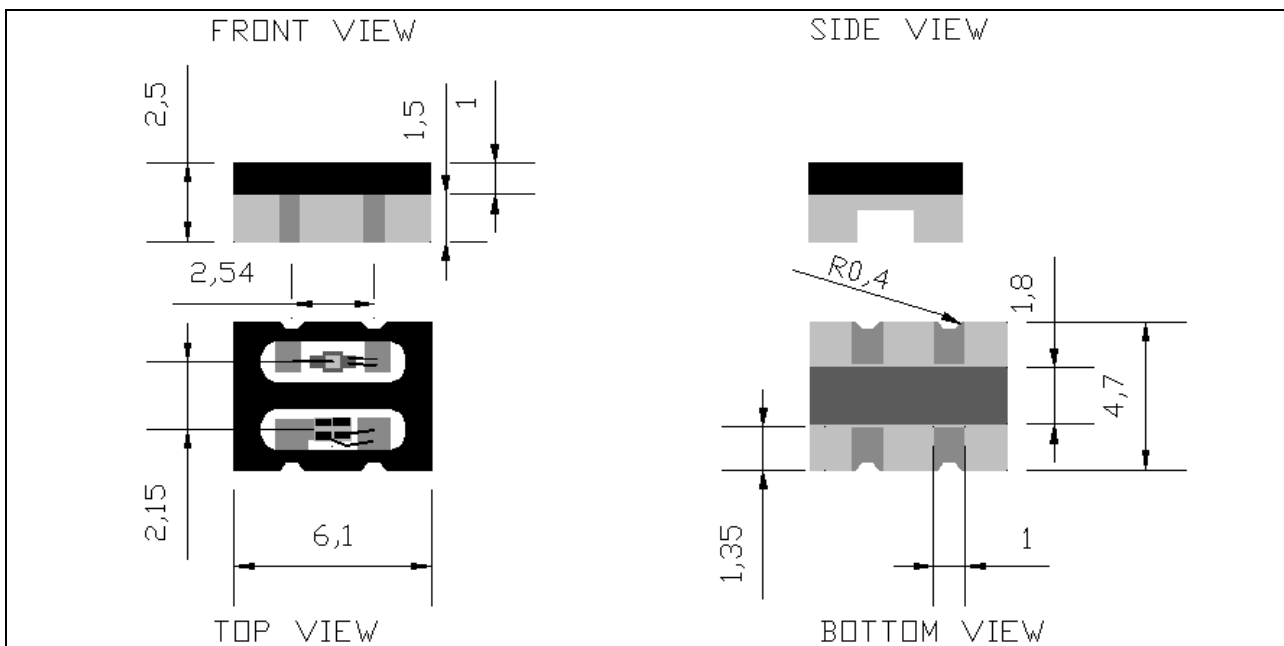

† See Figure 1

TYPICAL PERFORMANCE CURVES

Figure 1 – Normalized collector current VS Distance to reflective surface [mm] §

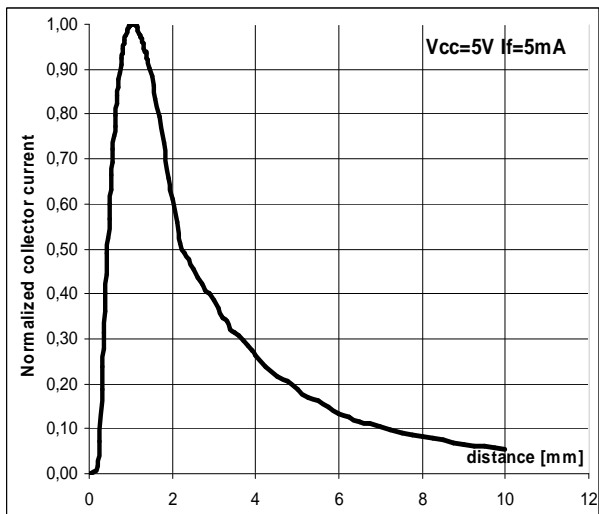

Figure 2 – Normalized collector current typical drift VS temperature [°C]

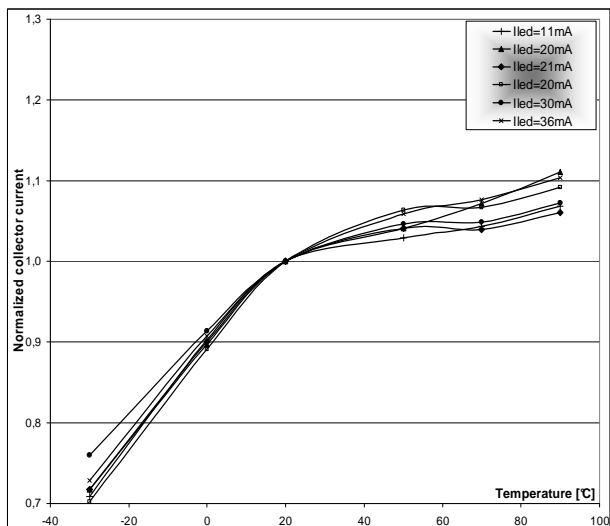

Figure 3 – Normalized collector current [Ic/Ic5mA] VS Forward led current [mA] §

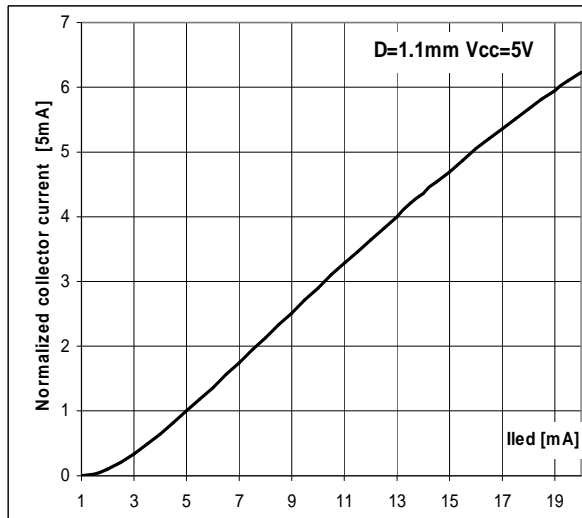
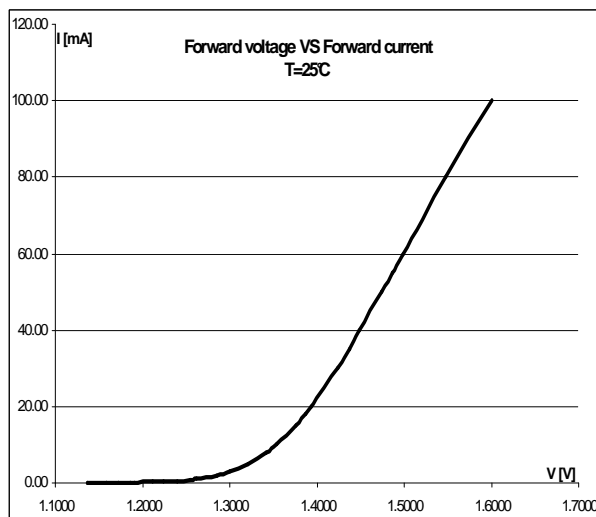
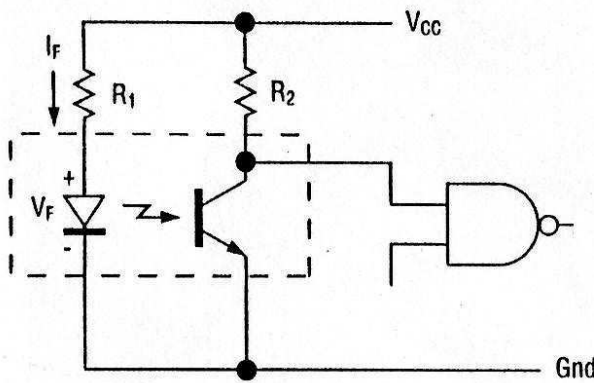

Figure 4 – Forward led current [mA] VS Forward led voltage [V] §



§ Ta=25°C unless otherwise noted



$$R_1 = \frac{V_{cc} - V_F}{I_F}$$

$$R_2 = \frac{V_{cc} - V_{ce_{sat}}}{I_{sat}}$$

Figure 5 – Digital interface

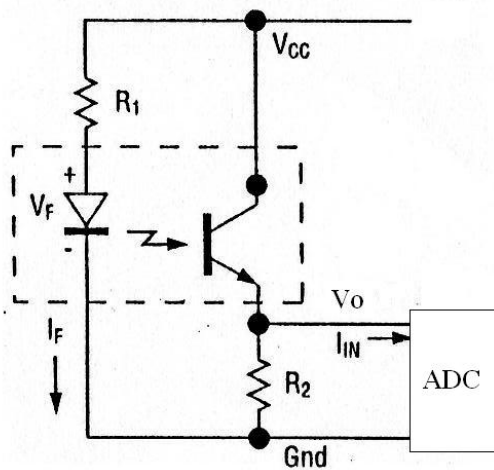

$$R_1 = \frac{V_{cc} - V_F}{I_F}$$

$$R_2 = \frac{V_{cc} - V_{ce}}{I_{R2}}$$

I_{IN} input current required for AD conversion
 V_o output analog voltage
 (the voltage gain is given by R_2 and I_F)

Figure 6 –Linear signal conversion to digital

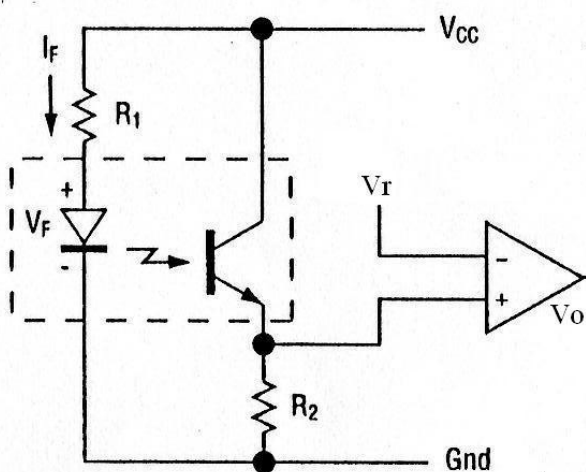

$$R_1 = \frac{V_{cc} - V_F}{I_F}$$

$$R_2 = \frac{V_{cc} - V_{ce}}{I_{R2}}$$

$$V_o = A_{ol} * (V_{R2} - V_r)$$

V_r voltage threshold
 V_o voltage digital output

Figure 7 – Threshold comparator