

MECL PLL COMPONENTS $\div 20/21$ DUAL MODULUS
SEMICONDUCTOR TECHNICAL DATA

Legacy Device: *Motorola MC12019*

The ML12019 is a divide by 20 and 21 dual modulus prescaler. It will divide by 20 when the modulus control input is HIGH and divide by 21 when the modulus control input is LOW.

- 225 MHz Toggle Frequency
- Low-Power 7.5 mA Maximum at 5.5 V
- Control Input is Compatible with Standard Motorola or Lansdale CMOS Synthesizers
- Emitter Follower Output
- Operating Temperature Range $T_A = -40$ to 85°C

P DIP 8 = PP
PLASTIC PACKAGE
CASE 626-04

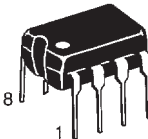

SO 8 = -5P
PLASTIC PACKAGE
CASE 751
(SO-8)



CROSS REFERENCE/ORDERING INFORMATION

PACKAGE	MOTOROLA	LANSDALE
P-DIP 8	MC12019P	ML12019PP
SO 8	MC12019D	ML12019-5P

Note: Lansdale lead free (**Pb**) product, as it becomes available, will be identified by a part number prefix change from **ML** to **MLE**.

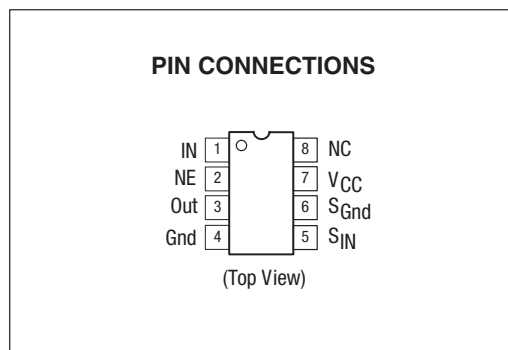
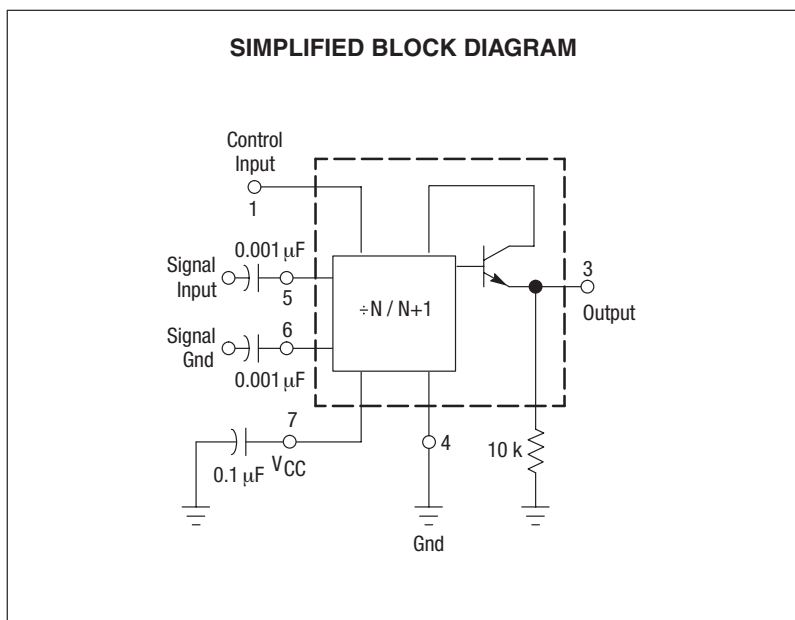

MAXIMUM RATINGS

Rating	Symbol	Value	Unit
Power Supply Voltage, Pin 7	V _{CC}	8.0	Vdc
Operating Temperature Range	T _A	-40 to +85	°C
Storage Temperature Range	T _{stg}	-65 to +175	°C

ELECTRICAL CHARACTERISTICS (V_{CC} = 4.5 to 5.5 V; T_A = -40 to 85°C), unless otherwise noted.)

Characteristic	Symbol	Min	Typ	Max	Unit
Toggle Frequency (Sine Wave Input)	f _{max}	225	-	-	MHz
	f _{min}	-	-	20	
Supply Current	I _{CC}	-	-	7.5	mA
Control Input HIGH (+20)	V _{IH}	2.0	-	-	V
Control Input LOW (+21)	V _{IL}	-	-	0.8	V
Output Swing Voltage (10 kΩ to ground)	V _{out}	600	-	1200	mVpp
Input Voltage Sensitivity 20 MHz to 225 MHz	V _{in}	-	-	-	mVpp
		200	-	800	
PLL Response Time (Notes 1 and 2)	t _{PLL}	-	-	t _{out-70}	ns

- NOTES:** 1. t_{PLL} = the period of time the PLL has from the prescaler rising output transition (50%) to the modulus control input edge transition (50%) to ensure proper modulus selection.
2. t_{out} = period of output waveform.

Figure 1. Generic block diagram showing prescaler connection to PLL device

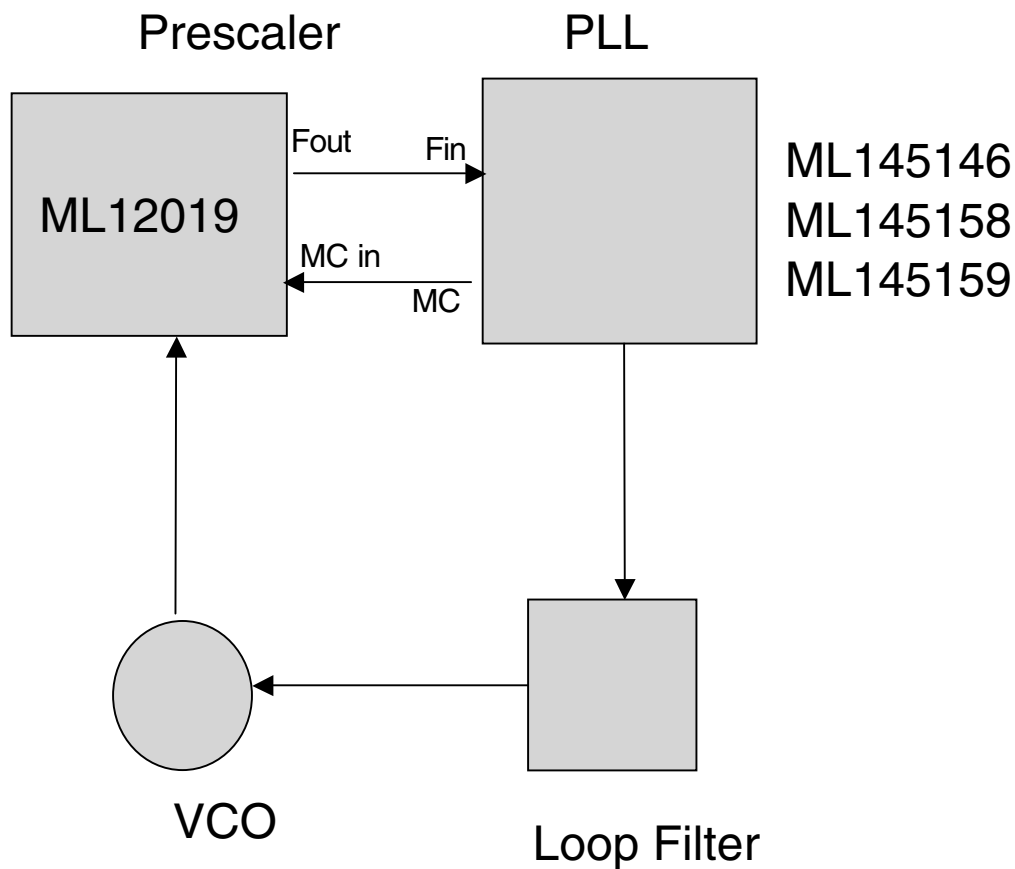
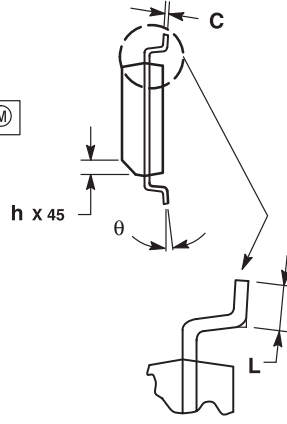
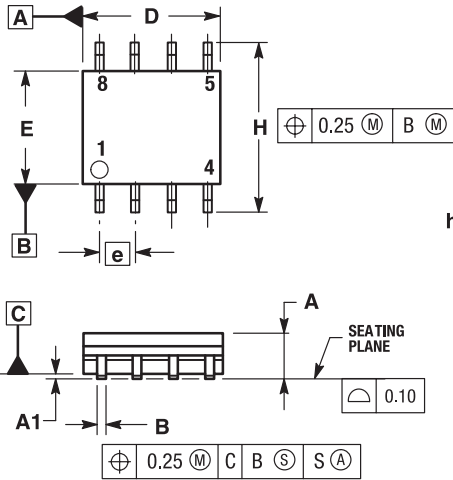

Figure 1 shows a generic block diagram for connecting a prescaler to a PLL device that supports dual modulus control. Application note AN535 describes using a two-modulus prescaler technique. By using a prescaler, higher frequencies can be achieved than by a single CMOS PLL device.

OUTLINE DIMENSIONS

SO 8= -5P
 PLASTIC PACKAGE
 (ML12019-5P)
 CASE 751-06
 (SO-8)
 ISSUE T



- NOTES:
1. DIMENSIONING AND TOLERANCING PER ASME Y14.5M, 1994.
 2. DIMENSIONS ARE IN MILLIMETER.
 3. DIMENSION D AND DO NOT INCLUDE MOLD PROTRUSION.
 4. MAXIMUM MOLD PROTRUSION 0.15 PER SIDE.
 5. DIMENSION B DOES NOT INCLUDE DAMBAR PROTRUSION. ALLOWABLE DAMBAR PROTRUSION SHALL BE 0.127 TOTAL IN EXCESS OF THE B DIMENSION AT MAXIMUM MATERIAL CONDITION.

MILLIMETERS		
DIM	MIN	MAX
A	1.35	1.75
A1	0.10	0.25
B	0.35	0.49
C	0.19	0.25
D	4.80	5.00
E	3.80	4.00
e	1.27 BSC	
H	5.80	6.20
h	0.25	0.50
L	0.40	1.25
θ	0°	7°

P DIP 8 = PP
 PLASTIC PACKAGE
 (ML12019PP)
 CASE 626-04

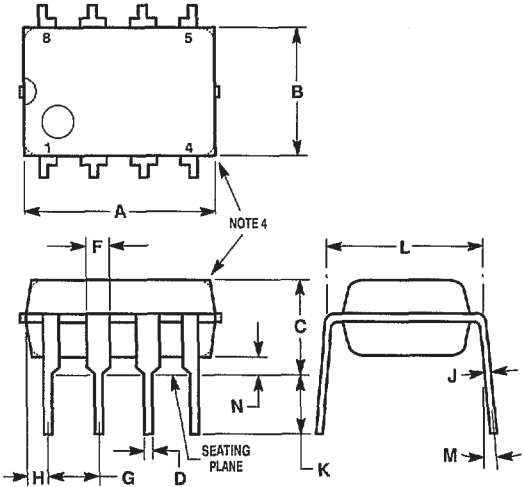

- NOTES:
1. LEAD POSITIONAL TOLERANCE:
 $\phi 0.13 (0.005) \text{ (M) T A (M) B (M)}$
 2. DIMENSION L TO CENTER OF LEADS WHEN FORMED PARALLEL.
 3. PACKAGE CONTOUR OPTIONAL (ROUND OR SQUARE CORNERS).
 4. DIMENSIONS A AND B ARE DATUMS.
 5. DIMENSIONING AND TOLERANCING PER ANSI Y14.5M, 1982.

DIM	MILLIMETERS		INCHES	
	MIN	MAX	MIN	MAX
A	9.40	10.16	0.370	0.400
B	6.10	6.60	0.240	0.260
C	3.94	4.45	0.155	0.175
D	0.38	0.51	0.015	0.020
F	1.02	1.52	0.040	0.060
G	2.54 BSC		0.100 BSC	
H	0.76	1.27	0.030	0.050
J	0.20	0.30	0.008	0.012
K	2.92	3.43	0.115	0.135
L	7.62 BSC		0.300 BSC	
M	— 10°		— 10°	
N	0.51	0.76	0.020	0.030

Lansdale Semiconductor reserves the right to make changes without further notice to any products herein to improve reliability, function or design. Lansdale does not assume any liability arising out of the application or use of any product or circuit described herein; neither does it convey any license under its patent rights nor the rights of others. "Typical" parameters which may be provided in Lansdale data sheets and/or specifications can vary in different applications, and actual performance may vary over time. All operating parameters, including "Typicals" must be validated for each customer application by the customer's technical experts. Lansdale Semiconductor is a registered trademark of Lansdale Semiconductor, Inc.