

INTELLIGENT **POWER²**[®]

for

Industrial/Automotive Applications

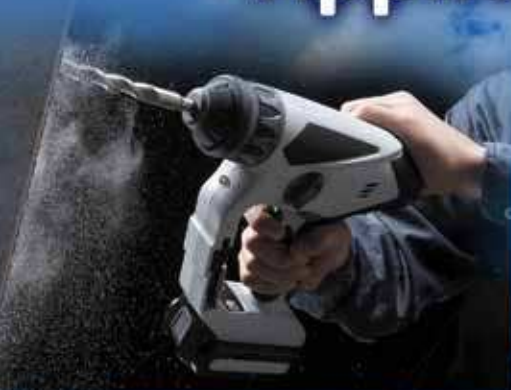

O₂Micro
Breaking Life into Mobility

Industrial/Automotive Product Guide

Part Number	Description	Cell(s)	Package(s) Available (Lead-free)	Page No.
Analog Front End (AFE)				
OZ9350	AFE with Cell Balance and I ² C Interface	4-7 Cells	16 QFN, SOP	5
Battery Management Units (BMUs) and Gauges (with cell balance)				
OZ890	High Power BMU	5-13 Cells	64 LQFP	6
OZ8920	High Power BMU	5-8 Cells	48 LQFP	7
OZ8930	High Power BMU	3-6 Cells	24 QFN, TSSOP	8
OZ8940	High Power BMU	6-12 Cells	32 LQFP	9
OZ9310	SBS Battery Gauge and Protection	3-4 Cells	40 QFN, 38 TSSOP	10
OZ9320/ OZ9324	SBS Battery Gauge and Protection	2 Cells	24 TSSOP/ 30 TSSOP	11
OZ9313	Battery Gauge for High Power BMU	Any Cells	30 TSSOP	12
Cell Monitors, BMUs and Gauges (without cell balance)				
OZ8800	Monitor and Secondary Protection	3-7 Cells	10 DFN	13
OZ8806	Monitor + High Accuracy Coulomb Counter	1-2 Cells	10 QFN	14
OZ8952	Low Cost Li-Ion BMU	3-4 Cells	16 SOP, SSOP	15
OZ8953	Low Cost Li-Ion BMU	5 Cells	16 SOP, SSOP	16
OZ8955	Low Cost Li-Ion BMU	3-5 Cells	16 SOP, SSOP	17
Hybrid Electric Vehicle (HEV)/Electric Vehicle (EV)				
OZ8902	Stackable High Power BMU with Cell Balance	12 Cells	48 LQFP	18
DC/DC Converter Controllers				
OZ8033	3A Low Dropout Linear Regulator		8 E-SOP	19
OZ8116/ OZ8138	Single/Dual Ultra High Efficiency DC/DC		16 QFN/ 24 QFN	20

Industrial/Automotive Product Guide

Part Number	Description	Package(s) Available (Lead-free)	Page No.
LED Controller ICs for GENERAL LIGHTING Applications – NON-ISOLATED			
OZ8022A/ OZ8022B/ OZ8022M	3-Step Dimming	SOT-23-6	21
OZ8022T	High Power Factor, 3-Step Dimming	16 QFN	22
OZ8022V	High Power Factor	SOT-23-6	23
OZ8024	Continuous Dimming	16 QFN, 8 SOP	24
LED Controller ICs for GENERAL LIGHTING Applications – ISOLATED			
OZ8027	High Power Factor	8 SOP	25
OZ8027A	High Power Factor, 3-Step Dimming	8 SOP	26
OZ8023/ OZ8025	High Power Factor, 3-Step Dimming for High Power Applications	8 SOP/SOT-23-6	27

Industrial/Automotive Applications

Mission Statement

Lead the industry as the supplier of highly integrated and efficient Industrial and Automotive solutions for battery and power management in electronic products for the Computer, Consumer, Industrial, Automotive, and Communications markets worldwide.

PRODUCTS

O₂Micro's *Intelligent Power for Industrial and Automotive Application* products cross three IC categories – **Battery**, **Power Management**, and **Lighting**.



Battery Management Unit (BMU) products are highly integrated, mixed signal ICs designed with **Cool Battery Technology**[®]. BMUs provide next generation, safe battery management.

DC/DC Controllers are **Power Management** ICs. Equipped with **Constant-Ripple-Current**[®] technology, they are specially developed to design high efficiency power supplies.

Lighting LED Drivers, part of the *Intelligent Lighting* family of ICs, include patented **Free Dimming**[™] technology for step dimming and continuous dimming control.



OZ9350

FEATURES

- Analog Front End (AFE) with Cell Balance and I₂C communications with a microcontroller
- Input: 4–7 cells series connected; Lithium Ion (Li-Ion), Li-Polymer, Phosphate and Lead acid (PbA) battery cells
- Output: Multiplexes and level shifts individual cell, battery pack, and chip internal temperature voltages to an analog output for a host microcontroller
- I²C BUS serial communication with host microcontroller
- Fast analog: Voltage output stable within 100µs after channel selection
- Integrated reverse voltage protection (0.9V typical threshold) to prevent cell damage
- Integrated Under-Voltage Lockout (UVLO) protection
- Integrated cell balance drivers eliminate external components
- 3.3V LDO with 25mA output drive ability to power microcontroller
- Integrated charge MOSFET driver (P-channel in high side or N-channel in low side) and discharge N-channel MOSFET driver (low side)
- Low power consumption modes: Full power < 80µA, Sleep < 10µA (5µA typical value at 25°C), and Power down < 1µA (0.1µA typical value at 25°C)

GENERAL DESCRIPTION

OZ9350 is an AFE IC for 4-7 cell battery pack applications. It is designed to work with a host microcontroller and its Analog-to-Digital Converter (ADC).

OZ9350's internal analog multiplexer level shifts and conditions the individual cell voltages becoming a ground referenced signal, that a microcontroller can directly measure, increasing accuracy, eliminating discrete components and simplifying analog design.

APPLICATIONS

- Electric Bicycle
- Power Tool
- Battery Backup System
- Hybrid Vehicle
- Portable Test Equipment
- Medical System
- Military Electronics

APPLICATION BLOCK DIAGRAM

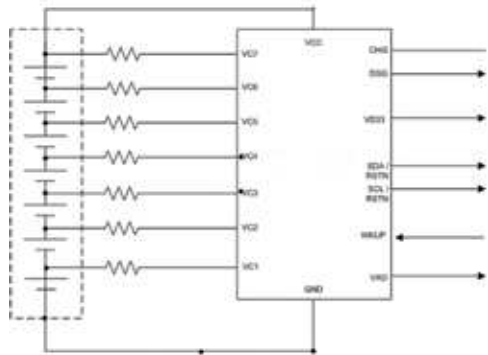

OZ890

FEATURES

- High power BMU
- Highly integrated battery pack monitor and protection
 - Li-Ion and Li-Polymer (Co, Mn and FeP chemistries) and NiMH battery cells
 - 5-13 cells standalone, and addressable up to 208 cells (16 BMU ICs)
 - 5-13 voltage channels, 3 external temperature channels and 1 current channel
 - Fully EEPROM programmable battery protection parameters
 - Built-in protection includes: over-voltage, under-voltage, over-current, short circuit, over-temperature, under-temperature, cell unbalance, and permanent failure
- External and Internal cell balancing
- Current measurement for coulomb counting with external microcontroller
- Low power consumption

GENERAL DESCRIPTION

OZ890 is a highly integrated IC for battery pack protection and monitoring, used to manage Li-Ion and Li-Polymer or Nickel Metal Hydride (NiMH) packs with 5-13 series cells.

With an integrated multi-channel, 16-bit Analog-to-Digital Converter (ADC), OZ890 continuously monitors each cell voltage, charge current, discharge current and pack temperature to provide maximum battery safety. It also provides a Permanent Failure function that will automatically assert a signal to blow an external fuse to open the power line or to issue an alarm to the user in extreme conditions.

OZ890 may be configured to work in standalone “hardware” mode or with a microcontroller in “software” mode by configuring the EEPROM.

APPLICATIONS

- Electric Bicycle
- Electric Motorcycle
- Power Tool
- Uninterruptable Power Supply (UPS) Backup Battery
- Electric Vehicle (EV/HEV/PHEV)

APPLICATION DIAGRAM

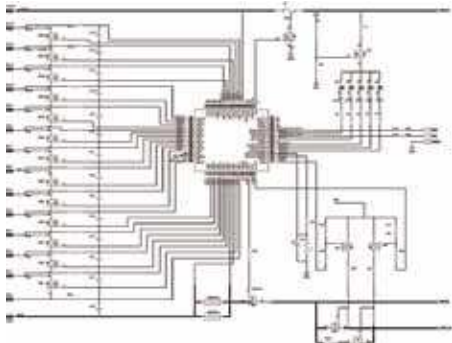

U.S. Patent #'s 6,744,394; 7,081,737; 7,161,520; 7,196,652; 7,352,155; 7,466,104; 7,629,771; 7,642,750; 7,679,324; 7,696,725; 7,701,177; 7,821,229; 7,973,514; 8,004,246; 8,030,895; 8,044,815; and more patents pending.

OZ8920

FEATURES

- High power BMU
- Highly integrated battery pack monitor and protection
 - Li-Ion and Li-Polymer (Co, Mn and FeP chemistries) and NiMH battery cells
 - 5-8 cells standalone, and addressable up to 144 cells (16 BMU ICs)
 - 5-8 voltage channels, 3 external temperature channels and 1 current channel
 - Fully EEPROM programmable battery protection parameters
 - Built-in protection includes: over-voltage, under-voltage, over-current, short circuit, over-temperature, under-temperature, cell unbalance, and permanent failure
- External and Internal cell balancing
- Current measurement for coulomb counting with external microcontroller
- Low power consumption

GENERAL DESCRIPTION

OZ8920 is a highly integrated IC for battery pack protection and monitoring, used to manage Li-Ion and Li-Polymer packs with 5-8 series cells.

With an integrated multi-channel 16-bit Analog-to-Digital Converter, OZ8920 continuously monitors each cell voltage, the charge current, discharge current and pack temperature to provide maximum battery safety. It also provides a Permanent Failure function that will automatically assert a signal to blow an external fuse to open the power line or to issue an alarm to the user in extreme conditions.

OZ8920 may be configured to work in standalone “hardware” mode or with a microcontroller in “software” mode by configuring the EEPROM.

APPLICATIONS

- Electric Bicycle
- Electric Motorcycle
- Power Tool
- Energy Storage System (ESS)/UPS Backup Battery

APPLICATION DIAGRAM

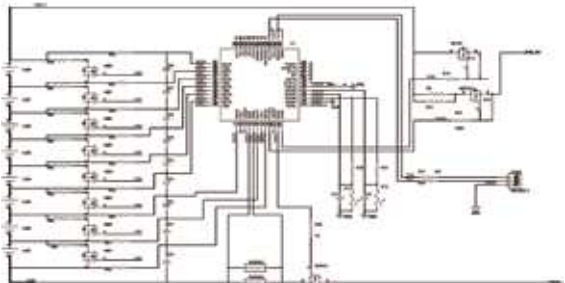

OZ8930

FEATURES

- High power BMU
- Highly integrated battery pack monitor and protection
 - Li-Ion and Li-Polymer, and Phosphate battery cells
 - 3-6 cells standalone
 - 3-6 voltage channels, 2 external temperature channels and 1 current channel
 - JEITA standard compliant
 - Self-diagnostics
 - OTP programmable battery protection parameters
 - Built-in protection includes: over-voltage, under-voltage, over-current (COC, DOC0, DOC1), short circuit, over-temperature, under-temperature, cell unbalance, and permanent failure
- Internal cell balancing
- Current measurement for coulomb counting with external microcontroller
- Low power consumption

GENERAL DESCRIPTION

OZ8930 is a highly integrated IC for battery pack protection and monitoring, used to manage Li-Ion and Li-Polymer packs with 3-6 series cells.

With an integrated multi-channel 14-bit Analog-to-Digital Converter, OZ8930 continuously monitors each cell voltage, charge current, discharge current and pack temperature to provide maximum battery safety. It also provides a Permanent Failure function that will automatically assert a signal to blow an external fuse to open the power line or to issue an alarm to the user in extreme conditions.

OZ8930 may be configured to work in standalone “hardware” mode or with a microcontroller in “software” mode by configuring the OTP programmable memory.

APPLICATIONS

- Power Tool
- Backup Power Supply

APPLICATION DIAGRAM

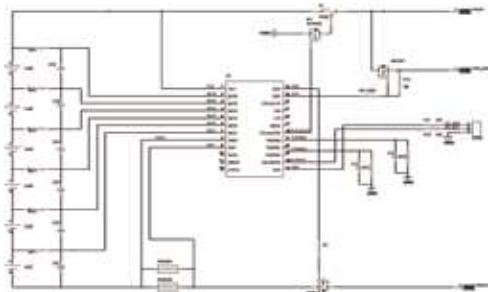

U.S. Patent #'s 6,744,394; 7,081,737; 7,161,520; 7,196,652; 7,352,155; 7,466,104; 7,629,771; 7,642,750; 7,696,725; 7,701,177; 7,821,229; 8,004,246; and more patents pending.

OZ8940

FEATURES

- High power BMU
- Highly integrated battery pack monitor and protection
 - Li-Ion and Li-Polymer (Co, Mn and FeP chemistries), NiMH and Fuel cells
 - 6-12 cells standalone
 - 6-12 voltage channels, 2 external temperature channels
 - Fully programmable battery protection parameters
 - Built-in protection includes: over-voltage, under-voltage, over-current, short circuit, over-temperature, under-temperature, cell unbalance, and permanent failure
- Internal cell balancing
- Low power consumption

GENERAL DESCRIPTION

OZ8940 is a highly integrated IC for battery pack protection and monitoring, used to manage Li-Ion and Li-Polymer packs with 6-12 series cells.

With an integrated multi-channel 12-bit ADC, OZ8940 continuously monitors each cell voltage and pack temperature to provide maximum battery safety. It also provides a Permanent Failure function that will automatically assert a signal to blow an external fuse to open the power line or to signal an alarm to the user.

OZ8940 may be configured to work in standalone “hardware” mode or with a microcontroller in “software” mode by configuring the EEPROM.

APPLICATIONS

- Electric Bicycle
- Electric Motorcycle
- Power Tool
- UPS Backup Battery
- Electric Vehicle (EV/HEV/PHEV)
- Fuel Cell

APPLICATION DIAGRAM

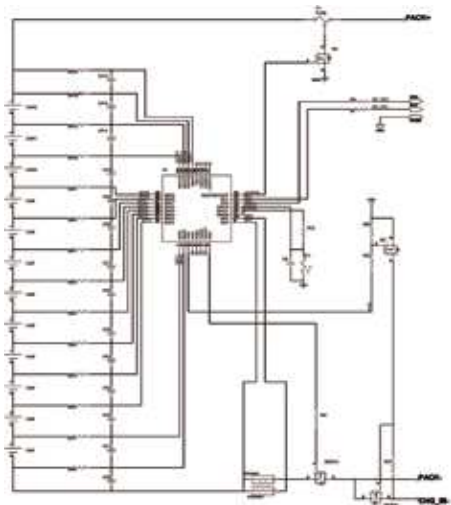

U.S. Patent #'s 6,744,394; 7,081,737; 7,161,520; 7,196,652; 7,352,155; 7,466,104; 7,629,771; 7,642,750; 7,696,725; 7,701,177; 7,821,229; 8,004,246; and more patents pending.

OZ9310

FEATURES

- Fully integrated, high accuracy battery gauge with protection functions for 3 and 4 cell Li-Ion and Li-Polymer batteries
- Compliant with Smart Battery Specification (SBS) version 1.1, IEEE1625, and JEITA
- Supports Intel NVDC and CBB topology
- Battery Gauge with hardware for impedance measurement
- Measures charge current and discharge current with a dedicated 16-bit ADC
- Monitors individual cell and terminal voltages with up to 15-bit resolution
- Integrated cell balancing circuits and temperature sensor
- Integrated, multiple-level cell protection includes: over-voltage, under-voltage, over-current, short circuit, over-temperature, under-temperature, cell unbalance, and permanent failure
- Embedded flash program and data storage allows flexible support of battery changing
- *Integrated* multi-GPIOs; 8-bit PWM with 2-bit pre-scalar (option); 10-bit PDM controller; 3.3V and 1.8V voltage regulators; and pre-charge, charge and discharge FET drivers
- Low standby current: 20 μ A typical

GENERAL DESCRIPTION

OZ9310 is a highly integrated battery gauge and protection IC. It measures the state-of-charge of a Li-Ion or Li-Polymer battery pack and its individual cells with a highly accurate, low power battery gauge function.

The Battery Gauge software calibrates itself automatically and continuously, without waiting for a full charge and discharge cycle to occur, significantly increasing the reliability and accuracy of the battery pack.

APPLICATIONS

- Notebook Computer
- Portable Equipment
- Test Equipment

APPLICATION DIAGRAM

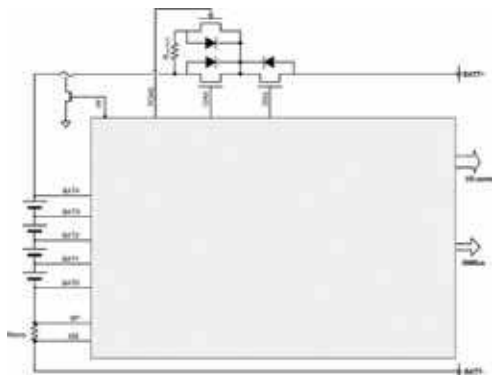

U.S. Patent #'s 6,744,394; 7,081,737; 7,095,221; 7,161,520; 7,196,652; 7,589,499; 7,646,169; 7,667,435; 7,696,725; 8,004,246; 8,030,973; 8,169,249; and more patents pending.

OZ9320/9324

FEATURES

- Fully integrated, high accuracy battery gauge with protection functions for 2-cell Li-Ion and Li-Polymer batteries
- Compliant with SBS version 1.1, IEEE1625, and JEITA
- Implements Intel NVDC and CBB topology
- Battery Gauge with hardware for impedance detection
- Measures charge current and discharge current with a dedicated 16-bit ADC
- Monitors individual cell and terminal voltages with up to 15-bit resolution
- Integrated cell balancing circuits and temperature sensor
- Integrated, multiple-level cell protection includes: over-voltage, under-voltage, over-current, short circuit, over-temperature, under-temperature, cell unbalance, and permanent failure
- Embedded flash program and data storage allows flexible support of battery changing
- **OZ9320:** *Integrated* multi-GPIOs; 8-bit Pulse Width Modulation (PWM) with 2-bit pre-scalar (option); 10-bit Pulse Density Modulation (PDM) controller; 3.3V and 1.8V voltage regulators; and pre-charge, charge/discharge FET drivers
- **OZ9324:** *Integrated* multi-GPIOs; 10-bit PDM controller; 3.3V and 1.8V voltage regulators; and pre-charge, charge/discharge FET drivers
- Low standby current: 20 μ A typical

GENERAL DESCRIPTION

OZ9320/24 are highly integrated battery gauge and protection ICs for 2-cell battery packs. Each measures the state-of-charge of a Li-Ion or Li-Polymer battery pack and its individual cells with a highly accurate, low power battery gauge function.

The Battery Gauge software calibrates itself automatically and continuously, without waiting for a full charge and discharge cycle to occur, significantly increasing the reliability and accuracy of the battery pack.

APPLICATIONS

- Netbook/Notebook Computer
- Tablet PC
- Digital Camcorder/Camera
- Portable Equipment

APPLICATION DIAGRAM

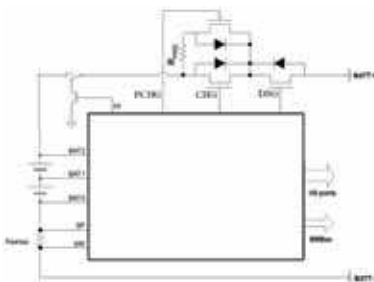

U.S. Patent #'s 6,744,394; 7,081,737; 7,095,221; 7,161,520; 7,196,652; 7,589,499; 7,646,169; 7,667,435; 7,696,725; 8,004,246; 8,030,973; 8,169,249; and more patents pending.

OZ9313

FEATURES

- Integrated, 8-bit microcontroller with high performance and low power consumption
- Integrated, highly accurate ADC with different types of BMU ICs in a high power battery, providing an accurate state-of-charge:
 - OZ890 +OZ9313: 5-13 cells
 - OZ8940 +OZ9313: 6-12 cells
 - OZ8920 +OZ9313: 5-8 cells
 - Stacked protection ICs + OZ9313
- SBS version 1.1 compatible; and supports JEITA
- Measures charge and discharge current with a dedicated 16-bit ADC
- Monitors individual cell and terminal voltages, and external temperature from BMU chips
- Integrated internal temperature sensor
- Programmed to scan BMU protection that includes: over-voltage, under-voltage, over-current, short circuit, over-temperature, and under-temperature
- Embedded 64k bytes flash and 1k bytes SRAM to support a variety of battery characteristics in high power applications
- Integrated 8-bit PWM with 2-bit pre-scalar; multi-GPIOs, 2 GPO; and 1.8V voltage regulator
- Full power and sleep modes; low sleep mode current < 10 μ A typical

GENERAL DESCRIPTION

OZ9313 is a highly accurate battery gauge designed to work with O₂Micro's high power battery protection BMU ICs. It directly measures charge and discharge current using its low power, sigma-delta ADC, resulting in accurate state-of-charge information.

OZ9313, with proprietary battery gauge software, automatically self-calibrates without waiting to complete a charge/discharge cycle, significantly increasing the reliability and accuracy of a variety of high power battery packs.

APPLICATIONS

- Electric Bicycle
- Electric Motorcycle
- Power Tool
- Backup Battery Pack

APPLICATION DIAGRAM

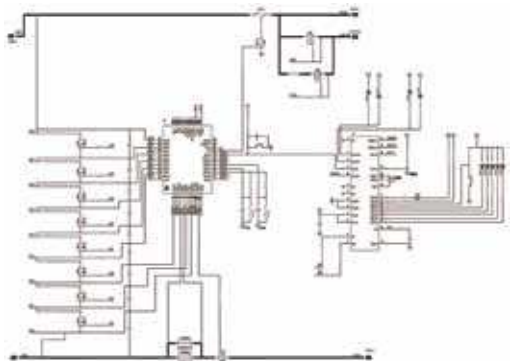

U.S. Patent #'s 6,744,394; 7,095,211; 7,161,520; 7,196,652; and more patents pending.

OZ8806

FEATURES

- Efficient Smart Phone battery monitor and high accuracy Coulomb Counter for 1-2 cell batteries
- Monitors:
 - Battery voltage
 - Temperature
 - Current for coulomb counting and battery gauge
- Resides in either the Host or the Battery Pack
- I²C communication protocol
- OCV (Open Circuit Voltage) detection when chip is in start-up and sleep modes
- Low power consumption

GENERAL DESCRIPTION

OZ8806 is a single cell battery monitor chip that works either in the battery pack or host. It provides current-flow, voltage, and temperature measurement data to support battery capacity monitoring in cost-sensitive applications.

Current measurement and coulomb counting is accomplished by monitoring the voltage drop across an external sense resistor. Voltage measurement is accomplished through a separate voltage-sense input. Two GPIOs may be used to detect battery temperature or for other purposes.

APPLICATIONS

- Netbook Computer
- Tablet
- Smart Phone
- PDA
- Cell Phone
- Handheld Rechargeable Battery

APPLICATION DIAGRAM

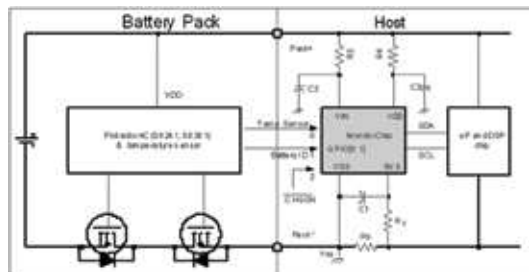

OZ8952

FEATURES

- 3-4 Cell Monitor and Protection for Li-Ion, Li-Polymer, and Phosphate batteries
- High accuracy over-voltage and under-voltage monitor and protection
- Built-in over-voltage, under-voltage, over-current, short circuit, over-temperature protection
- Three-level, high accuracy over-current protection (DOC1, DOC2, SC)
- Three modes for current fault release
 - Charger-in release
 - Load-open release
 - Timer release (optional)
- Indicates OV (Over-voltage) and PF (Permanent Failure)
- Low Power Consumption

GENERAL DESCRIPTION

OZ8952 is a highly integrated, low cost, battery pack protection and monitor IC used to manage Li-Ion and Li-Polymer packs with 3-4 cells.

OZ8952 has high accuracy voltage detection. It uses lower resistance for current sense to reduce power dissipation, while maintaining high accuracy current detection.

APPLICATIONS

- Power Tool
- Notebook Computer
- UPS
- Remote Controlled Vehicle

APPLICATION DIAGRAM

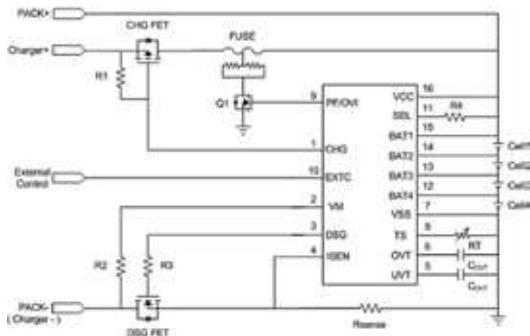

OZ8955

FEATURES

- Highly integrated 3-5 Cell Monitor and Protection circuit for Li-Ion and Li-Polymer batteries
- High accuracy fault protection, with time delay to prevent false trigger
 - Over-voltage and under-voltage detection
 - Over-temperature detection
 - Permanent fault protection
 - Charging permission check
- Self-contained charge/discharge power path control with strong power MOSFET drivers
- Open cell tap and Load (OL) detection
- Charger detection
- Pre-charge enable
- LED alarm indicator
- Low power consumption

GENERAL DESCRIPTION

OZ8955 is a highly integrated, low cost, protection and monitoring IC for battery packs with 3-5 Li-Ion or Li-Polymer cells.

One IC for 12V – 18V power tools results in one PCB design. No software programming necessary, simply use O₂Micro's PC-based design tool to load parameters; quick easy design. Manufacturing line flexibility for running changes.

APPLICATIONS

- Power Tool/Appliance
- Notebook Computer
- UPS
- Remote Controlled Vehicle

APPLICATION DIAGRAM

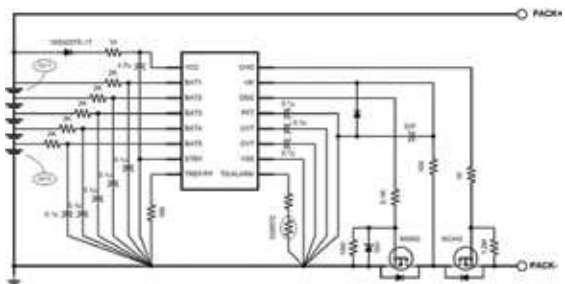

OZ8902

FEATURES

- Data acquisition for 6-12 cell battery packs using Li-Ion, Li-Polymer, LiFePO₄, and Nickel Metal Hydride (NiMH) battery cells; fuel cells, PbA batteries, or ultra-capacitors
- Compliant with ISO16949 standard
- High accuracy cell voltage detection: <+15mV (-40 ~ 105°C)
- 12-bit, multi-channel ADC
- Trigger scan enables current and voltage measurement synchronization
- Embedded, non-volatile memory
- Cell integrated balance drivers with high drive capability
- Integrated 5.0V voltage regulator
- 8-wire SPI Vertical communication bus (V-SPI bus)
- 4-wire SPI Lateral bus (L-SPI bus) to communicate with any SPI bus device (e.g., active balance controller)
- Broken cell tap connection detection
- Low power modes: Scan, 5.2mA @ full speed [5ms scan cycle], Standby (60µA), and Power down (50µA)

GENERAL DESCRIPTION

OZ8902 is a data acquisition chip, designed for use in the battery management systems of electric vehicle applications. It monitors the battery module cell voltages and temperatures.

OZ8902 uses Balancing on demand[®] to achieve cell balancing. Cell balancing is controlled by the host by setting the balance registers for cell voltage balance. Cell balance ensures longer battery life.

APPLICATIONS

- Electric Bicycle
- Electric Motorcycle
- UPS Backup Battery
- Electric Vehicle (EV/HEV/PHEV)

APPLICATION DIAGRAM

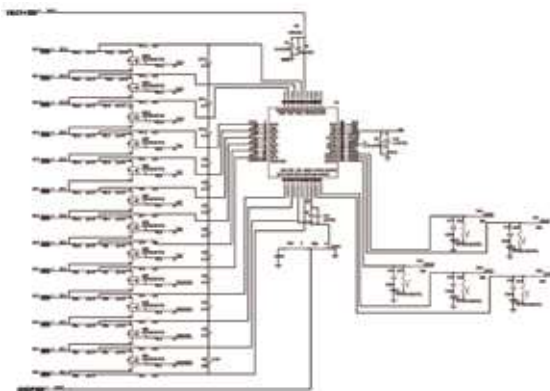

U.S. Patent #'s 7,081,737; 7,352,155; 7,629,771; 7,679,324; 7,696,725; 7,796,069; 7,973,514; 8,004,246; 8,015,452; 8,022,669; 8,030,895; and more patents pending.

OZ8033

FEATURES

- Ultra low dropout (LDO) regulator
- 170mV dropout
- 1.5% Accuracy over Line/Load/Temperature
- Fast load Transient Response
- Internal soft start function
- Protection includes: Over-current (OCP), Output Under-voltage (UVP), Under-voltage Lockout (UVLO) for VDDA and VIN, and Over-temperature (OTP)

GENERAL DESCRIPTION

OZ8033 is a fast, high current, and ultra low dropout (LDO) regulator designed for DSP Core, front side bus VTT and other similar applications.

The device uses two power supplies: VIN and VDDA. VIN is the main supply providing the output current; VDDA is an auxiliary supply for all other internal circuitry. The voltages of both power supplies are internally monitored by the Under-voltage Lockout circuitry, which disables the chip when any of these voltages is lower than the safe operation threshold.

APPLICATIONS

- Notebook Computer
- Industrial Computer
- Automotive Infotainment
- FPGA
- DSP Core and I/O Voltage
- Front Side Bus VTT
- Motherboard

APPLICATION DIAGRAM

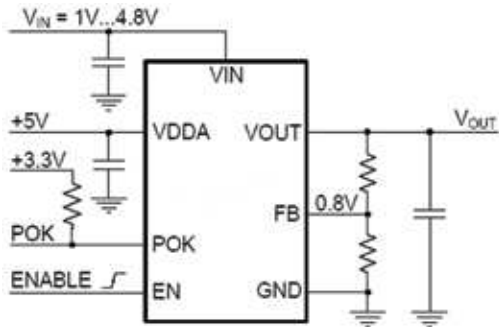

OZ8116/8138

FEATURES

- **OZ8116:** Single DC/DC SMPS controller with integrated drivers
- **OZ8138:** Dual DC/DC SMPS controller with integrated drivers
- Constant-Ripple-Current® control allows designing for optimum inductor size
- High efficiency up to 94%; High light load efficiency >85% at 100mA
- VREF accuracy of 1.5%
- Input voltage from 3V to 25V; Output voltage adjustable from 0.5V to 2.75V
- Output current – up to 15A
- Output protection: latched over- and under-voltage, and over-current
- Input protection: under-voltage lockout on VDDA and VIN
- Soft start at start-up
- Soft stop at shutdown

GENERAL DESCRIPTION

OZ8116/8138 are DC/DC Switched Mode Power Supply (SMPS) controllers specially developed to provide power control for next generation microprocessors, their peripherals and chipsets.

These ICs step down the high battery voltage to low output voltages in the range of 0.5V to 2.75V. High efficiency, DC accuracy and excellent transient response make OZ8116/8138 the perfect choice to supply low voltage CPU peripherals, chipset cores, and graphics processors.

APPLICATIONS

- Power Supplies for Notebook CPU, Microcontrollers and Peripherals
- Industrial Computer
- GPS

APPLICATION DIAGRAMS

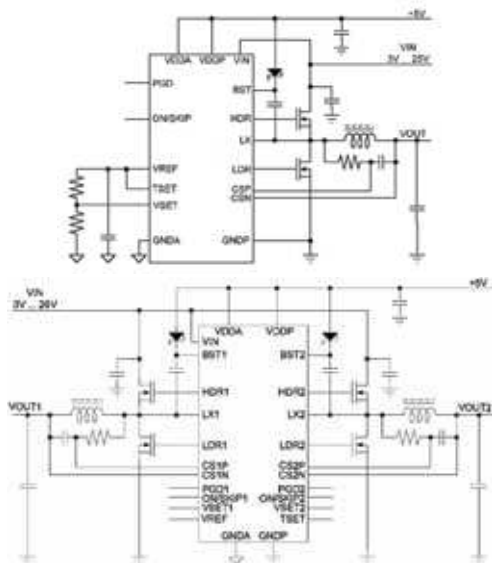

U.S. Patent #'s 6,844,710; 6,965,221; 7,098,642; 7,202,650; 7,466,113; 7,598,718; 7,816,896; and more patents pending.

OZ8022A/B/M

FEATURES

- 3-level forward analog dimming control using a wall switch
- Quasi-resonant converter controller for high-brightness LEDs
- Low start-up current and operating current, maximizing conversion efficiency
- Peak current-mode control simplifies circuit design
- Under-voltage lockout with hysteresis
- Minimum off-time control for light-load operation, maximizing efficiency
- Provides complete protection functions:
 - OZ8022A/B: Maximum gate drive output at 19.5V
 - OZ8022M: Maximum gate drive output clamp
 - Over-voltage for IC bias voltage
 - Cycle-by-cycle current limit
 - LED short circuit; output over-voltage; and internal over-temperature

GENERAL DESCRIPTION

The OZ8022A/B/M are controllers for Buck converters that use quasi-resonant conversion technology. Each can be used to drive high-brightness LEDs in of-line applications.

OZ8022A/B/M provide proprietary patented Free Dimming™ technology to control LED brightness using an ON/OFF wall switch.

APPLICATIONS

- LED Driver

APPLICATION DIAGRAM

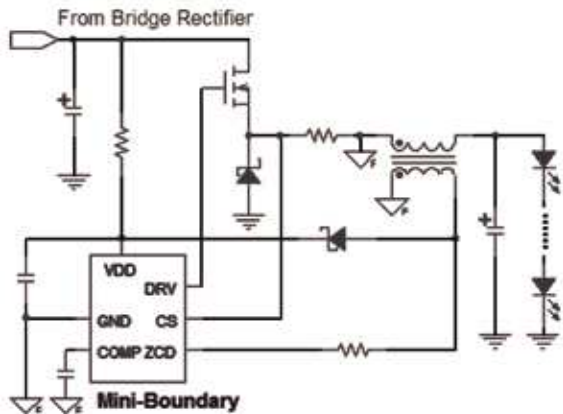

OZ8024

FEATURES

- Proprietary continuous PWM dimming technology using a wall switch
- Quasi-resonant converter controller for high-brightness LEDs
- Low stand-by and operating current
- Peak current-mode control simplifies circuit design
- Under-voltage lockout with hysteresis
- Minimum off-time control at high-input voltage operation condition
- Provides complete protection functions:
 - Maximum gate drive output
 - Over-voltage for IC bias voltage
 - Cycle-by-cycle current limit
 - LED short circuit; output over-voltage; and internal over-temperature

GENERAL DESCRIPTION

The OZ8024 is a controller for Buck converters that uses quasi-resonant conversion technology to provide regulated power for high-brightness LEDs in offline applications.

It provides a patented technology to control LED brightness using an ON/OFF wall switch. End-users can simply select a desired LED brightness.

APPLICATIONS

- LED Driver

APPLICATION DIAGRAM

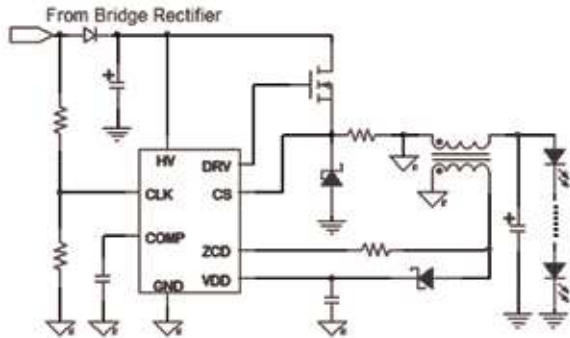

OZ8027

FEATURES

- Primary side control, AC/DC converter controller
- High power factor with wide range input voltage
- Constant current output
- Fixed operation frequency
- Built-in high-voltage startup circuit
- Compatible with neon indicators in wall switch
- Provides complete protection functions:
 - VDD over-voltage
 - VDD under-voltage lockout with hysteresis
 - Open and Short LED
 - Primary side cycle-by-cycle current limit
 - Maximum gate drive output clamp
 - Over-temperature

GENERAL DESCRIPTION

The OZ8027 is a primary side control, LED driver controller. It can be used in high power factor AC/DC converter applications.

OZ8027 works with neon indicators in a traditional wall switch, without interference.

APPLICATIONS

- LED Lighting

APPLICATION DIAGRAM

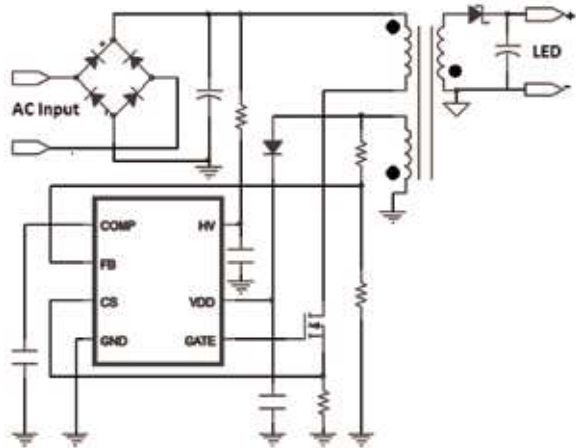

OZ8027A

FEATURES

- Primary side control, AC/DC converter controller
- High power factor with wide range input voltage
- Constant current output
- 3-level analog dimming control using a wall switch
- Fixed operation frequency
- Built-in high-voltage startup circuit
- Compatible with neon indicators in wall switch
- Provides complete protection functions:
 - VDD over-voltage
 - VDD under-voltage lockout with hysteresis
 - Open and Short LED
 - Primary side cycle-by-cycle current limit
 - Maximum gate drive output clamp
 - Over-temperature

GENERAL DESCRIPTION

The OZ8027A is a primary side control, LED driver controller. It can be used in high power factor AC/DC converter applications.

OZ8027A works with neon indicators in a traditional wall switch, without interference.

APPLICATIONS

- LED Lighting

APPLICATION DIAGRAM

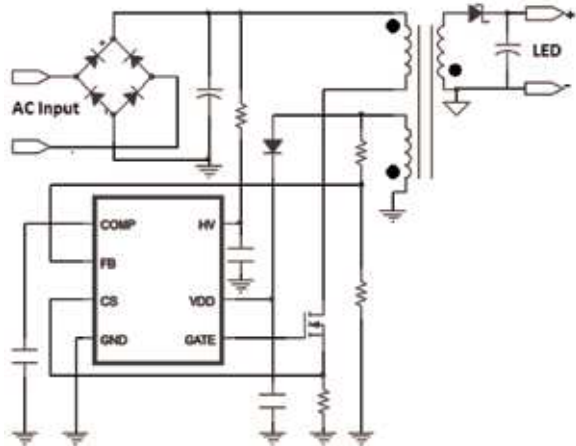

OZ8023/8025

FEATURES – OZ8023

- Quasi-resonant converter controller
- Built-in high-voltage startup circuit
- Voltage-mode control simplifies circuit design
- Under-voltage lockout with hysteresis
- Minimum off-time control for light-load operation, maximizing efficiency
- Excellent line-voltage regulation
- Provides complete protection functions:
 - Clamped gate drive output
 - Over-voltage for IC bias voltage
 - Cycle-by-cycle current limit
 - Output short circuit; over load; output over-voltage; and internal over-temperature

FEATURES – OZ8025

- Secondary side LED controller
- 3-level analog dimming control using a wall switch
- Low operating current
- Provides complete protection functions:
 - VDD over-voltage
 - Output over-voltage
 - Internal over-temperature

GENERAL DESCRIPTION

The **OZ8023** is a voltage-mode, quasi-resonant converter controller, suitable for offline, AC/DC flyback converter applications. It can be used as a single-stage power factor correction controller for an isolated power supply or LED driver applications.

The **OZ8025** is a controller for an isolated LED driver application. It provides a proprietary 3-level dimming control to LEDs using an ON/OFF wall switch.

APPLICATIONS

- Isolated LED Driver

APPLICATION DIAGRAM OZ8023/8025

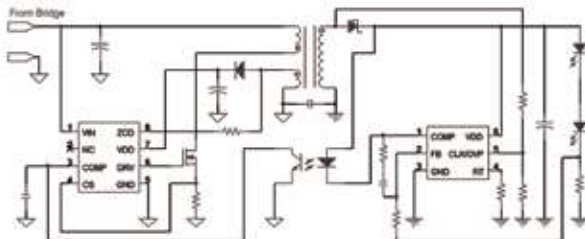

Company Background

Founded in April 1995, O₂Micro® International Limited (NASDAQ: OIIM) designs, develops and markets innovative **power management** and **e-commerce** components for the Computer, Consumer, Industrial/Automotive, and Communications markets.

O₂Micro maintains an extensive portfolio of intellectual property, and has numerous Trademark Applications and Copyright Registrations.

The company's extensive list of customers includes many of the world's leading electronics manufacturers.

For additional information, including sales office locations, please visit the O₂Micro web site at **www.o2micro.com**.

Copyright © 2012-13 by O₂Micro. All rights reserved.

PO₂WER, the O₂Micro logo, O₂Micro, Cool Battery Technology, Constant-Ripple-Current, Balancing on demand, and combinations thereof are registered trademarks of O₂Micro. Free Dimming and combinations thereof are trademarks of O₂Micro.

All other trademarks are the property of their respective owners.

R-092112

O₂Micro®
Breathing Life into Mobility