

FEATURES

- Access Times of 70, 90 and 120ns
- Single 5V±10% Power Supply
- Simple Byte and Page Write
- Low Power CMOS:
 - 80 mA Active Current
 - 3 mA Standby Current
- Fast Write Cycle Times
- Software Data Protection
- CMOS & TTL Compatible Inputs and Outputs
- Endurance:
 - 10,000 Write Cycles
 - 100,000 Write Cycles (optional)
- Data Retention: 10 Years
- Available in the following package:
 - 28-Pin 600 mil Ceramic DIP
 - 32-Pin Ceramic LCC (450x550 mils)

DESCRIPTION

The PYA28HC256 is a 5 Volt 32Kx8 EEPROM. The device supports 64-byte page write operation. The PYA28HC256 features $\overline{\text{DATA}}$ and Toggle Bit Polling as well as a system software scheme used to indicate early completion of a

Write Cycle. The device also includes user-optional software data protection. Data Retention is 10 Years. The device is available in a 28-Pin 600 mil wide Ceramic DIP and 32-Pin LCC.

FUNCTIONAL BLOCK DIAGRAM

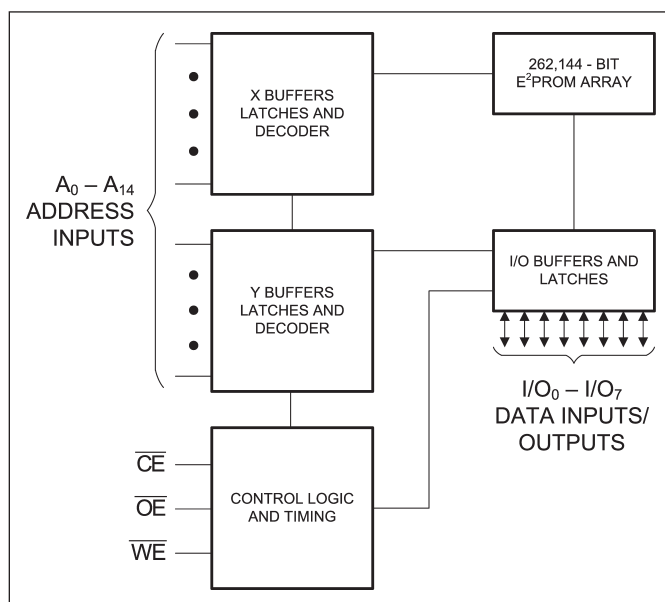

PIN CONFIGURATION

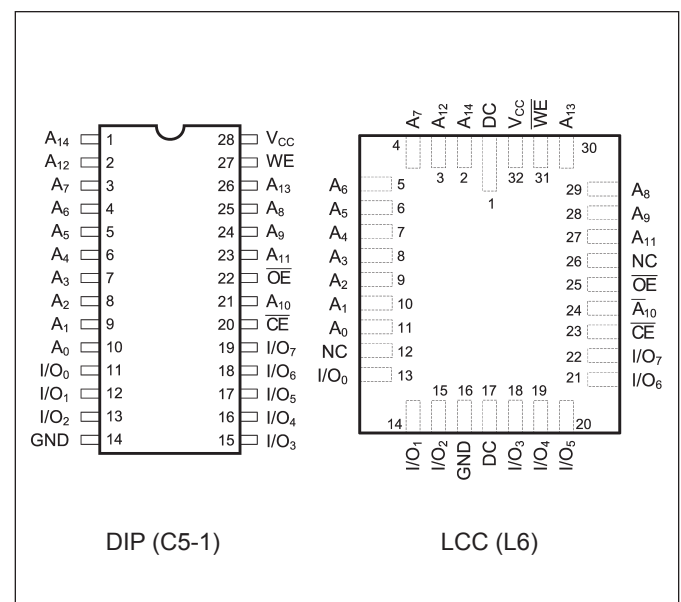



OPERATION

READ

Read operations are initiated by both \overline{OE} and \overline{CE} LOW. The read operation is terminated by either \overline{CE} or \overline{OE} returning HIGH. This two line control architecture eliminates bus contention in a system environment. The data bus will be in a high impedance state when either \overline{OE} or \overline{CE} is HIGH.

BYTE WRITE

Write operations are initiated when both \overline{CE} and \overline{WE} are LOW and \overline{OE} is HIGH. The PYA28HC256 supports both a \overline{CE} and \overline{WE} controlled write cycle. That is, the address is latched by the falling edge of either \overline{CE} or \overline{WE} , whichever occurs last. Similarly, the data is latched internally by the rising edge of either \overline{CE} or \overline{WE} , whichever occurs first. A byte write operation, once initiated, will automatically continue to completion.

PAGE WRITE

The page write feature of the PYA28HC256 allows 1 to 64 bytes of data to be consecutively written to the PYA28HC256 during a single internal programming cycle. The host can fetch data from another device within the system during a page write operation (change the source address), but the page address (A_6 through A_{14}) for each subsequent valid write cycle to the part during this operation must be the same as the initial page address. The bytes within the page to be written are specified with the A_0 through A_5 inputs.

The page write mode can be initiated during any write operation. Following the initial byte write cycle, the host can write an additional 1 to 63 bytes in the same manner as the first byte was written. Each successive byte load cycle, started by the \overline{WE} HIGH to LOW transition, must begin within 150 μ s of the falling edge of the preceding \overline{WE} . If a subsequent \overline{WE} HIGH to LOW transition is not detected within 150 μ s, the internal automatic programming cycle will commence. There is no page write window limitation. Effectively, the page write window is

infinitely wide, so long as the host continues to access the device within the byte load cycle time of 150 μ s.

WRITE STATUS BITS

The PYA28HC256 provides the user two write operation status bits. These can be used to optimize a system write cycle time. The status bits are mapped onto the I/O bus as shown below.

DATA POLLING

The PYA28HC256 features \overline{DATA} Polling as a method to indicate to the host system that the byte write or page write cycle has completed. \overline{DATA} Polling allows a simple bit test operation to determine the status of the PYA28HC256, eliminating additional interrupts or external hardware. During the internal programming cycle, any attempt to read the last byte written will produce the complement of that data on I/O_7 (i.e., write data=0xxx xxxx, read data=1xxx xxxx). Once the programming cycle is complete, I/O_7 will reflect true data. Note: If the PYA28HC256 is in the protected state and an illegal write operation is attempted, \overline{DATA} Polling will not operate.

TOGGLE BIT

The PYA28HC256 also provides another method for determining when the internal write cycle is complete. During the internal programming cycle, I/O_6 will toggle from HIGH to LOW and LOW to HIGH on subsequent attempts to read the device. When the internal cycle is complete the toggling will cease and the device will be accessible for additional read or write operations.





MAXIMUM RATINGS⁽¹⁾

Sym	Parameter	Value	Unit
V _{CC}	Power Supply Pin with Respect to GND	-0.3 to +6.25	V
V _{TERM}	Terminal Voltage with Respect to GND (up to 6.25V)	-0.5 to +6.25	V
T _A	Operating Temperature	-55 to +125	°C
T _{BIAS}	Temperature Under Bias	-55 to +125	°C
T _{STG}	Storage Temperature	-65 to +150	°C
P _T	Power Dissipation	1.0	W
I _{OUT}	DC Output Current	50	mA

RECOMMENDED OPERATING CONDITIONS

Grade ⁽²⁾	Ambient Temp	GND	V _{CC}
Military	-55°C to +125°C	0V	5.0V ± 10%

CAPACITANCES⁽⁴⁾

(V_{CC} = 5.0V, T_A = 25°C, f = 1.0MHz)

Sym	Parameter	Conditions	Typ	Unit
C _{IN}	Input Capacitance	V _{IN} = 0V	10	pF
C _{OUT}	Output Capacitance	V _{OUT} = 0V	10	pF

DC ELECTRICAL CHARACTERISTICS

(Over Recommended Operating Temperature & Supply Voltage)⁽²⁾

Sym	Parameter	Test Conditions	Min	Max	Unit
V _{IH}	Input High Voltage		2.0	V _{CC} + 0.3	V
V _{IL}	Input Low Voltage		-0.5 ⁽³⁾	0.8	V
V _{HC}	CMOS Input High Voltage		V _{CC} - 0.2	V _{CC} + 0.5	V
V _{LC}	CMOS Input Low Voltage		-0.5 ⁽³⁾	0.2	V
V _{OL}	Output Low Voltage (TTL Load)	I _{OL} = +2.1 mA, V _{CC} = Min		0.45	V
V _{OH}	Output High Voltage (TTL Load)	I _{OH} = -0.4 mA, V _{CC} = Min	2.4		V
I _{LI}	Input Leakage Current	V _{CC} = Max V _{IN} = GND to V _{CC}	-10	+10	µA
I _{LO}	Output Leakage Current	V _{CC} = Max, $\overline{CE} = V_{IH}$, V _{OUT} = GND to V _{CC}	-10	+10	µA
I _{SB}	Standby Power Supply Current (TTL Input Levels)	$\overline{CE} \geq V_{IH}$, $\overline{OE} = V_{IL}$, 90, 120ns V _{CC} = Max, f = Max, Outputs Open	—	3	mA
		70ns		60	mA
I _{SB1}	Standby Power Supply Current (CMOS Input Levels)	$\overline{CE} \geq V_{HC}$, V _{CC} = Max, f = 0, Outputs Open, V _{IN} ≤ V _{LC} or V _{IN} ≥ V _{HC}	—	300	µA
I _{CC}	Supply Current	$\overline{CE} = \overline{OE} = V_{IL}$, $\overline{WE} = V_{IH}$, All I/O's = Open, Inputs = V _{CC} = 5.5V	—	80	mA

Notes:

- Stresses greater than those listed under MAXIMUM RATINGS may cause permanent damage to the device. This is a stress rating only and functional operation of the device at these or any other conditions above those indicated in the operational sections of this specification is not implied. Exposure to MAXIMUM rating conditions for extended periods may affect reliability.
- Extended temperature operation guaranteed with 400 linear feet per minute of air flow.
- Transient inputs with V_{IL} and I_{IL} not more negative than -3.0V and -100mA, respectively, are permissible for pulse widths up to 20ns.
- This parameter is sampled and not 100% tested.



POWER-UP TIMING

Symbol	Parameter	Max	Unit
t_{PUR}	Power-up to Read operation	100	μ s
t_{PUW}	Power-up to Write operation	5	ms

AC ELECTRICAL CHARACTERISTICS—READ CYCLE

($V_{CC} = 5V \pm 10\%$, All Temperature Ranges)⁽²⁾

Sym	Parameter	-70		-90		-120		Unit
		Min	Max	Min	Max	Min	Max	
t_{AVAV}	Read Cycle Time	70		90		120		ns
t_{AVQV}	Address Access Time		70		90		120	ns
t_{ELQV}	Chip Enable Access Time		70		90		120	ns
t_{OLQV}	Output Enable Access Time		35		40		50	ns
t_{ELQX}	Chip Enable to Output in Low Z	0		0		0		ns
t_{EHQZ}	Chip Disable to to Output in High Z		35		40		50	ns
t_{OLQX}	Output Enable to Output in Low Z	0		0		0		ns
t_{OHQZ}	Output Disable to Output in High Z		35		40		50	ns
t_{AVQX}	Output Hold from Address Change	0		0		0		ns

TIMING WAVEFORM OF READ CYCLE

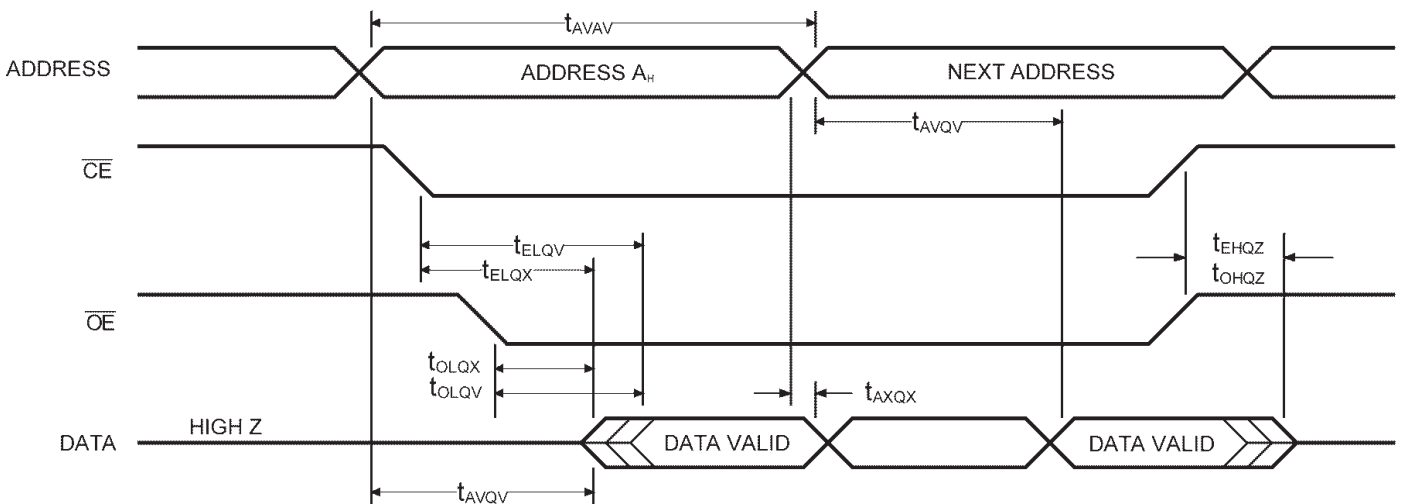

**AC CHARACTERISTICS—WRITE CYCLE** $(V_{CC} = 5V \pm 10\%, \text{ All Temperature Ranges})^{(2)}$

Symbol	Parameter	70 / 90 / 120		Unit
		Min	Max	
t_{WHWL1} t_{EHEL1}	Write Cycle Time		10	ms
t_{AVEL} t_{AVWL}	Address Setup Time	0		ns
t_{ELAX} t_{WLAX}	Address Hold Time	50		ns
t_{WLEL} t_{ELWL}	Write Setup Time	0		ns
t_{WHEH}	Write Hold Time	0		ns
t_{OHEL} t_{OHWL}	\overline{OE} Setup Time	10		ns
t_{WHOL}	\overline{OE} Hold Time	10		ns
t_{ELEH} t_{WLWH}	\overline{WE} Pulse Width	100		ns
t_{DVEH} t_{DVWH}	Data Setup Time	50		ns
t_{EHDX} t_{WHDX}	Data Hold Time	0		ns
t_{EHEL2} t_{WHWL2}	Byte Load Cycle Time	0.2	150	μ s
t_{ELWL}	\overline{CE} Setup Time	1		μ s
t_{OVHWL}	Output Setup Time	1		μ s
t_{EHWH}	\overline{CE} Hold Time	1		μ s
t_{WHOH}	\overline{OE} Hold Time	1		μ s



TIMING WAVEFORM OF BYTE WRITE CYCLE (\overline{CE} CONTROLLED)

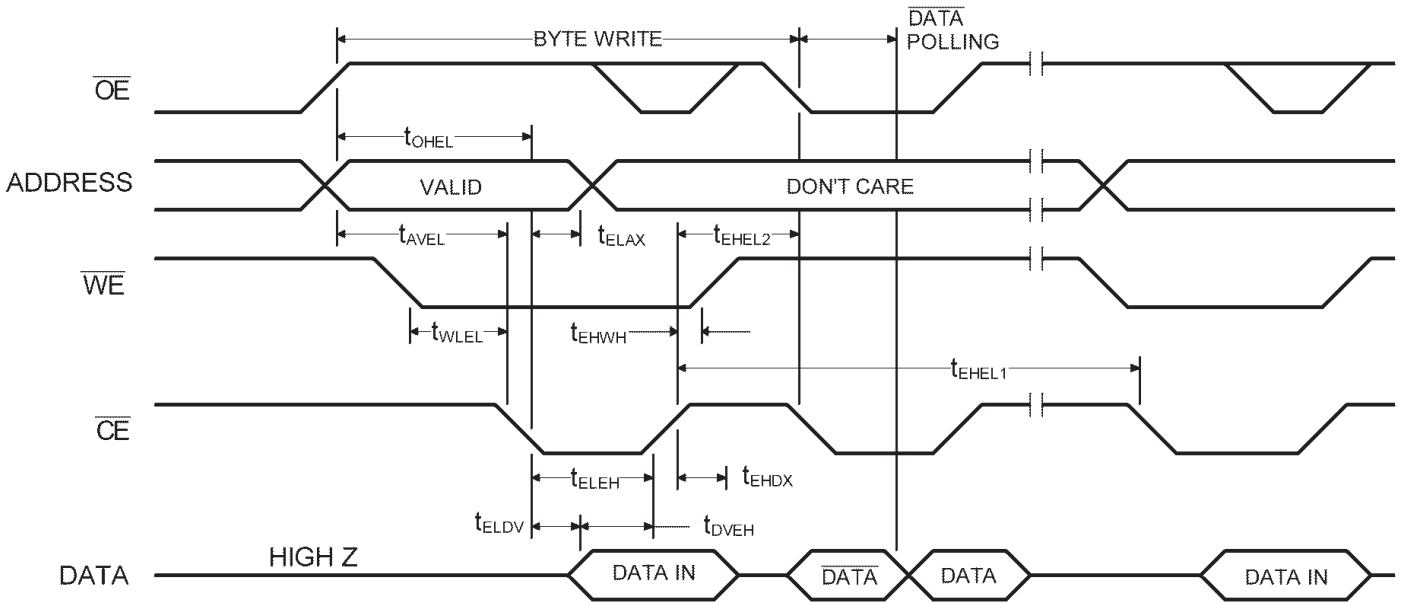

TIMING WAVEFORM OF BYTE WRITE CYCLE (\overline{WE} CONTROLLED)

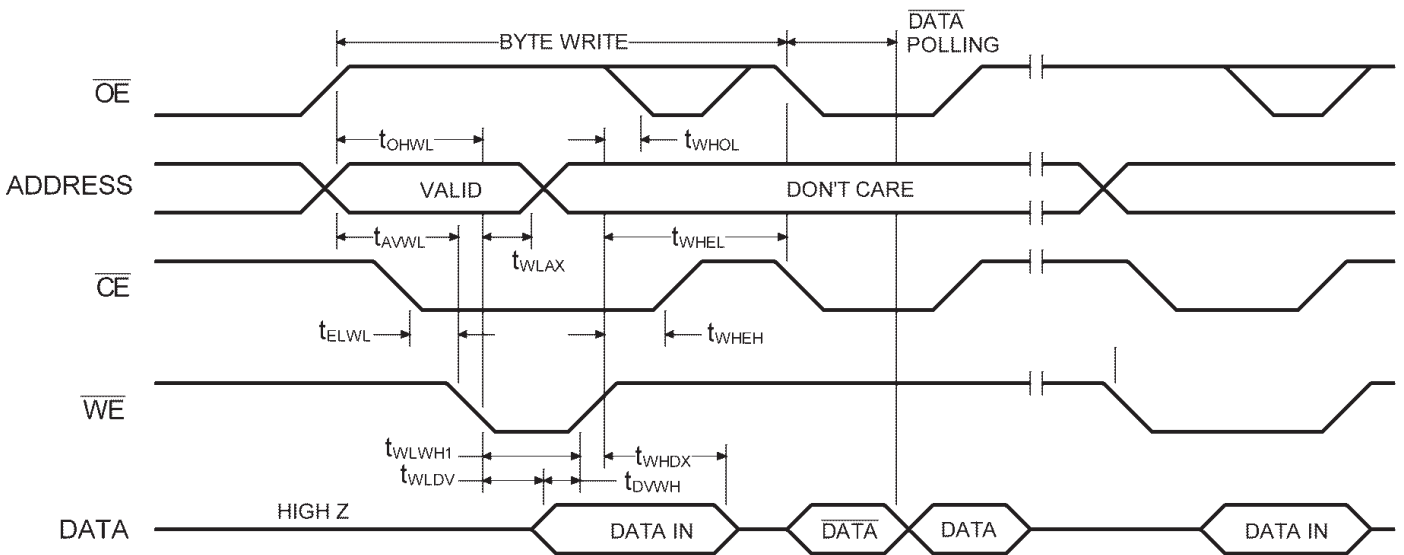



TIMING WAVEFORM OF PAGE WRITE CYCLE

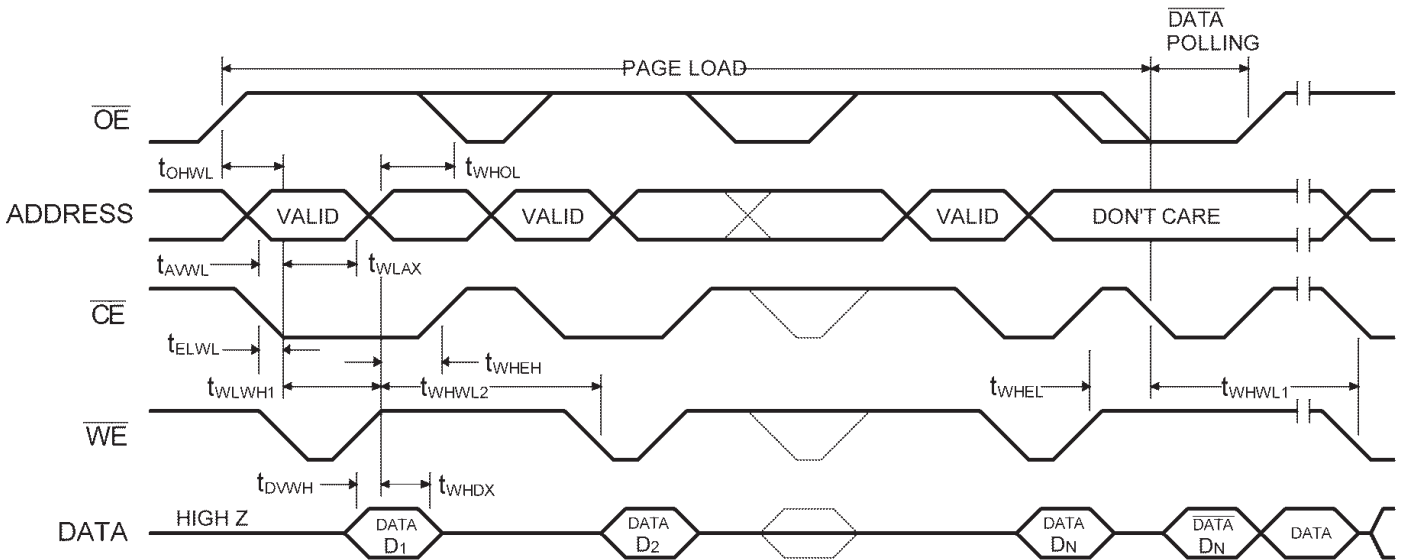

NOTES:

- For each successive write within the page write operation, A_6-A_{14} should be the same. Otherwise, writes to an unknown address could occur.
- Between successive byte writes within a page write operation, \overline{OE} can be strobed LOW. For example, this can be done with \overline{CE} and \overline{WE} HIGH to fetch data from another memory device within the system for the next write. Alternatively, this can be done with \overline{WE} HIGH and \overline{CE} LOW, effectively performing a polling operation.
- The timings shown above are unique to page write operations. Individual byte load operations within the page write must conform to either the \overline{CE} or \overline{WE} controlled write cycle timing.



WRITE SEQUENCE FOR SOFTWARE DATA PROTECTION

SOFTWARE SEQUENCE TO DE-ACTIVATE SOFTWARE DATA PROTECTION

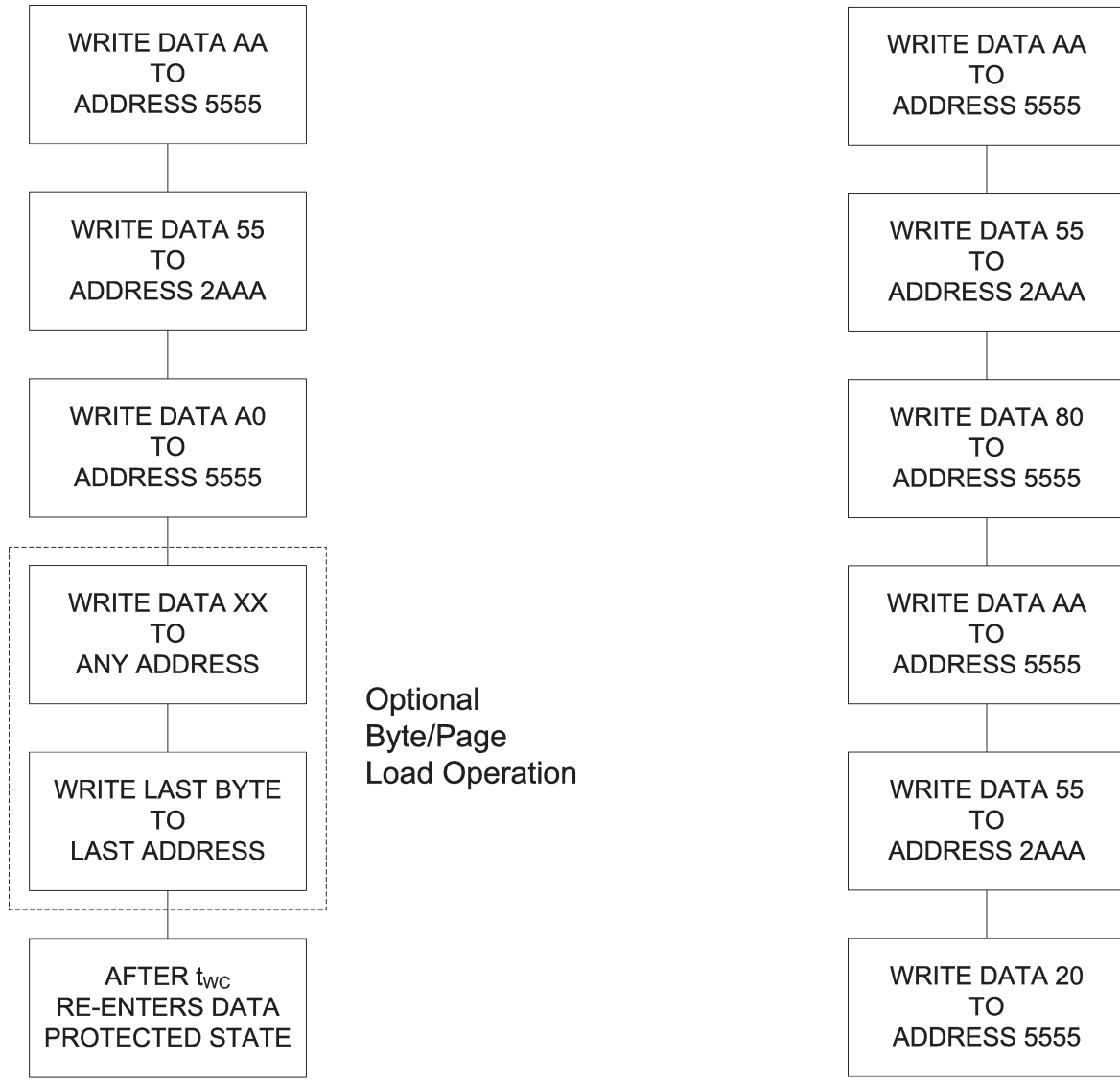

(SDP Set)

(SDP Reset)



AC TEST CONDITIONS

Input Pulse Levels	GND to 3.0V
Input Rise and Fall Times	10ns
Input Timing Reference Level	1.5V
Output Timing Reference Level	1.5V
Output Load	See Figure 1

TRUTH TABLE

Mode	\overline{CE}	\overline{OE}	\overline{WE}	I/O
Read	L	L	H	D _{OUT}
Write	L	H	L	D _{IN}
Write Inhibit	X	L	X	—
Write Inhibit	X	X	H	—
Standby	H	X	X	High Z
Output Disable	X	H	X	High Z

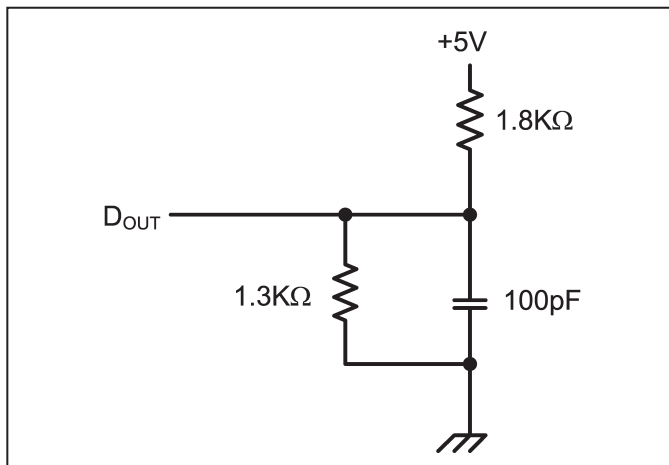

Figure 1. Output Load



ORDERING INFORMATION

PYA28HC256

 x xx x x
 Device Type Endurance Speed Package Processing

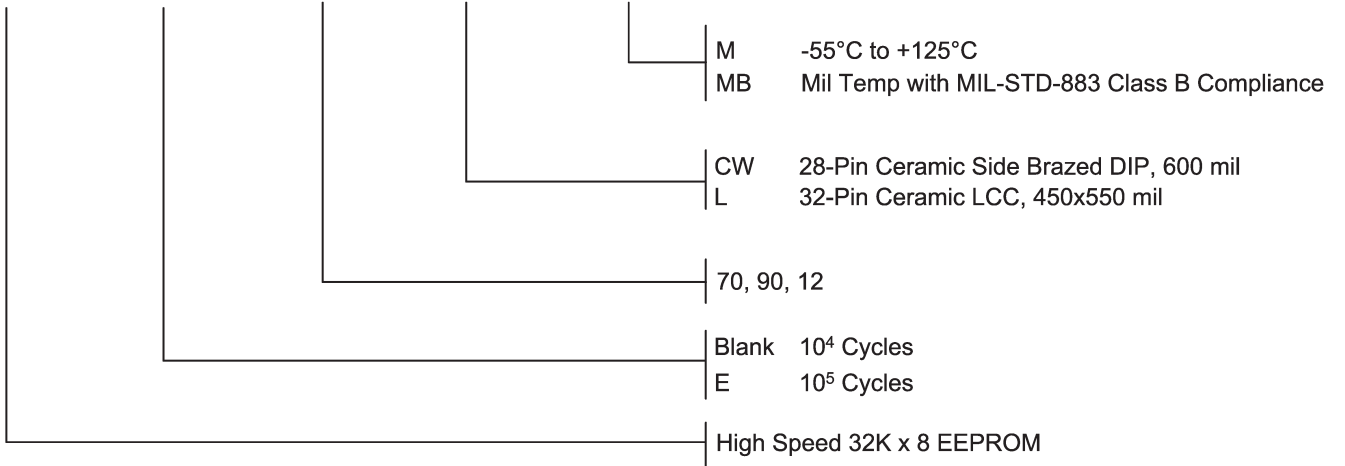



Pkg #	C5-1	
# Pins	28 (600 mil)	
Symbol	Min	Max
A	-	0.232
b	0.014	0.026
b2	0.045	0.065
C	0.008	0.018
D	-	1.490
E	0.500	0.610
eA	0.600 BSC	
e	0.100 BSC	
L	0.125	0.200
Q	0.015	0.060
S1	0.005	-
S2	0.005	-

SIDE BRAZED DUAL IN-LINE PACKAGE (600 mils)

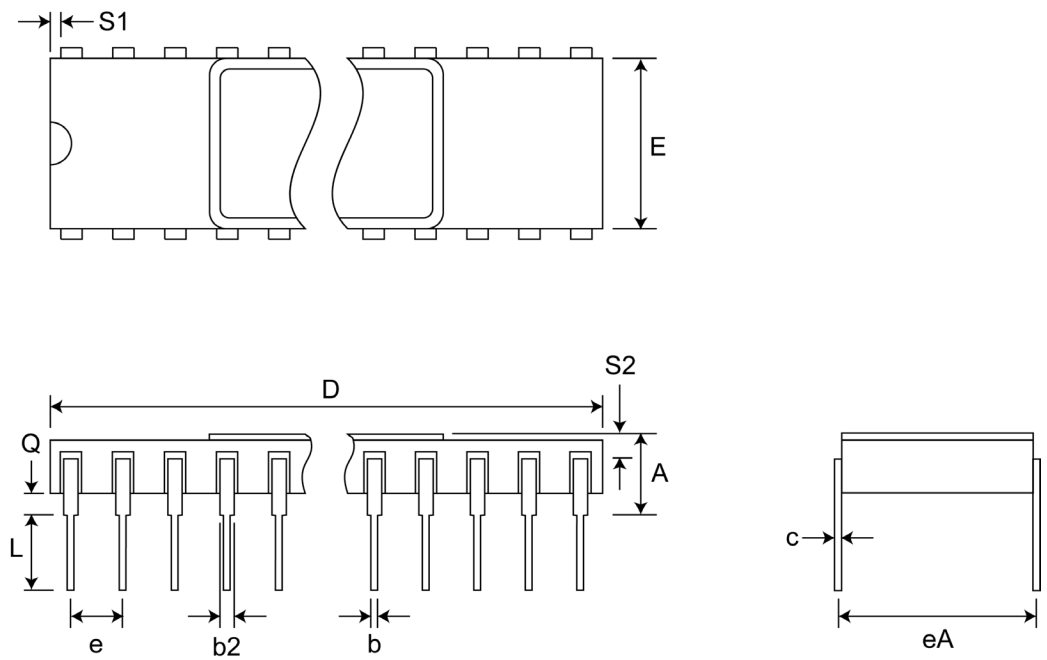

Pkg #	L6	
# Pins	32	
Symbol	Min	Max
A	0.060	0.075
A1	0.050	0.065
B1	0.022	0.028
D	0.442	0.458
D1	0.300 BSC	
D2	0.150 BSC	
D3	-	0.458
E	0.540	0.560
E1	0.400 BSC	
E2	0.200 BSC	
E3	-	0.558
e	0.050 BSC	
h	0.040 REF	
j	0.020 REF	
L	0.045	0.055
L1	0.045	0.055
L2	0.075	0.095
ND	7	
NE	9	

RECTANGULAR LEADLESS CHIP CARRIER

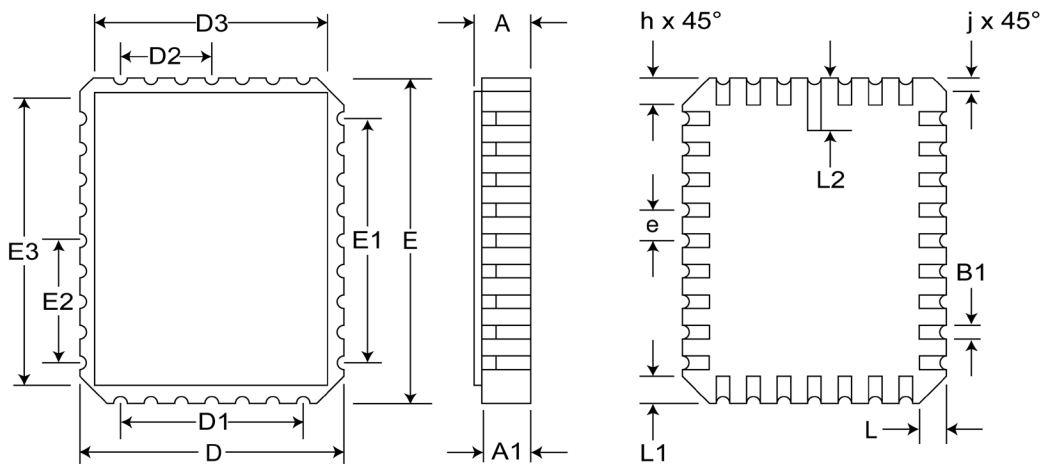

**REVISIONS**

DOCUMENT NUMBER	EEPROM106
DOCUMENT TITLE	PYA28HC256 - HIGH SPEED 32K x 8 EEPROM

REV	ISSUE DATE	ORIGINATOR	DESCRIPTION OF CHANGE
OR	Jan 2011	JDB	New Data Sheet
A	Nov 2011	JDB	Updated Ordering Info