

FEATURES

- EPROM Technology for reprogramming
- High Speed
 - 25/35/45/55 ns (Commercial)
 - 25/35/45/55 ns (Military)
- Low Power Operation:
 - 660 mW Commercial
 - 770 mW Military
- Single 5V±10% Power Supply

- Windowed devices for reprogramming
- Fully TTL Compatible Inputs and Outputs
- Standard Pinout (JEDEC Approved)
 - 24-Pin 300 mil Windowed Cerdip (PY263)
 - 24-Pin 300 mil Non-Windowed Plastic DIP (PY263)
 - 24-Pin 600 mil Windowed Cerdip (PY264)
 - 24-Pin 600 mil Non-Windowed Plastic DIP (PY264)



DESCRIPTION

The PY263 and PY264 are 8Kx8 CMOS PROMs. The devices are available in windowed packages which when exposed to UV light, the memory content in the PROM is erased and can be reprogrammed. EPROM technology is used in the memory cells for programming. The EPROM requires a 12.5V for programming. Devices are tested to insure that performance of the device meets the DC and AC specification limits after customer programming.

To perform a read operation from the device, \overline{CS} is LOW. The memory contents in the address established by the Address pins (A_0 to A_{12}) will become available on the outputs (O_0 to O_7).

The PY263 is available in 24-pin 300 mil Ceramic DIPs (Windowed) and Plastic DIPs (Non-Windowed).

The PY264 is available in 24-pin 600 mil Ceramic DIPs (Windowed) and Plastic DIPs (Non-Windowed).



FUNCTIONAL BLOCK DIAGRAM

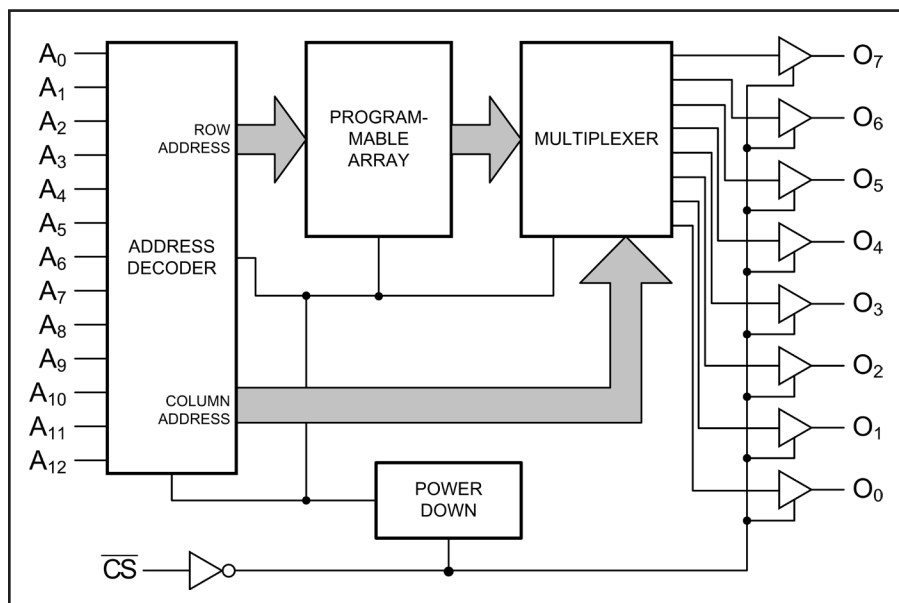

PIN CONFIGURATION

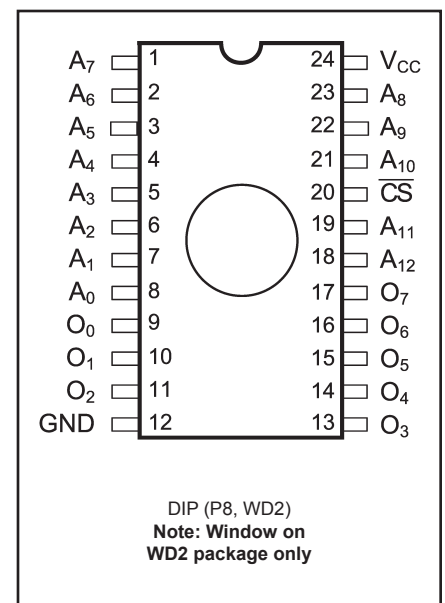



MAXIMUM RATINGS⁽¹⁾

Sym	Parameter	Value	Unit
V _{CC}	Power Supply Pin with Respect to GND	-0.5 to +7	V
V _{TERM}	Terminal Voltage with Respect to GND (up to 7.0V)	-0.5 to V _{CC} + 0.5	V
V _{PP}	Program Voltage	13	V
T _A	Operating Temperature	-55 to +125	°C
T _{BIAS}	Temperature Under Bias	-55 to +125	°C
T _{STG}	Storage Temperature	-65 to +150	°C
P _T	Power Dissipation	1.0	W
I _{OUT}	DC Output Current	50	mA

RECOMMENDED OPERATING CONDITIONS

Grade ⁽²⁾	Ambient Temp	GND	V _{CC}
Commercial	0°C to 70°C	0V	5.0V ± 10%
Military	-55°C to +125°C	0V	5.0V ± 10%

CAPACITANCES⁽⁴⁾

(V_{CC} = 5.0V, T_A = 25°C, f = 1.0MHz)

Sym	Parameter	Conditions	Typ	Unit
C _{IN}	Input Capacitance	V _{IN} =0V	10	pF
C _{OUT}	Output Capacitance	V _{OUT} =0V	10	pF

DC ELECTRICAL CHARACTERISTICS

(Over Recommended Operating Temperature & Supply Voltage)⁽²⁾

Sym	Parameter	Test Conditions	PY263 / PY264		Unit	
			Min	Max		
V _{IH}	Input High Voltage		2.0	V _{CC}	V	
V _{IL}	Input Low Voltage		-0.5 ⁽³⁾	0.8	V	
V _{HC}	CMOS Input High Voltage		V _{CC} - 0.2	V _{CC} + 0.5	V	
V _{LC}	CMOS Input Low Voltage		-0.5 ⁽³⁾	0.2	V	
V _{OL}	Output Low Voltage (TTL Load)	I _{OL} = +16 mA, V _{CC} = Min.		0.4	V	
V _{OH}	Output High Voltage (TTL Load)	I _{OH} = - 4 mA, V _{CC} = Min	2.4		V	
I _{LI}	Input Leakage Current	V _{CC} = Max, V _{IN} = GND to V _{CC}	COM	-10	+10	μA
			MIL	-40	+40	μA
I _{LO}	Output Leakage Current	V _{CC} = Max, $\overline{CE} = V_{IH}$, V _{OUT} = GND to V _{CC}	COM	-10	+10	μA
			MIL	-40	+40	μA
V _{PP}	Programming Supply Voltage		12	13	V	
I _{PP}	Programming Supply Current			50	mA	
V _{IHP}	Input HIGH Programming Voltage		4.75		V	
V _{ILP}	Input LOW Programming Voltage			0.4	V	

POWER DISSIPATION CHARACTERISTICS VS. SPEED

Sym	Parameter	Temperature Range	-25	-35	-45	-55	Unit
I _{CC}	Dynamic Operating Current	Commercial	120	100	100	100	mA
		Military	140	120	120	120	mA

* V_{CC} = 5.5V. Tested with outputs open. f = Max. Switching inputs are 0V and 3V. $\overline{CS} = V_{IL}$.



AC ELECTRICAL CHARACTERISTICS—READ CYCLE

($V_{CC} = 5V \pm 10\%$, All Temperature Ranges)⁽²⁾

Sym	Parameter	-25		-35		-45		-55		Unit
		Min	Max	Min	Max	Min	Max	Min	Max	
t_{AA}	Address to Output Valid		25		35		45		55	ns
t_{HZCS}	Chip Select Inactive to High Z		12		20		30		35	ns
t_{ACS}	Chip Select Active to Output Valid		12		20		30		35	ns
t_{PU}	Chip Select Active to Power-Up	0		0		0		0		ns

TIMING WAVEFORM OF READ CYCLE

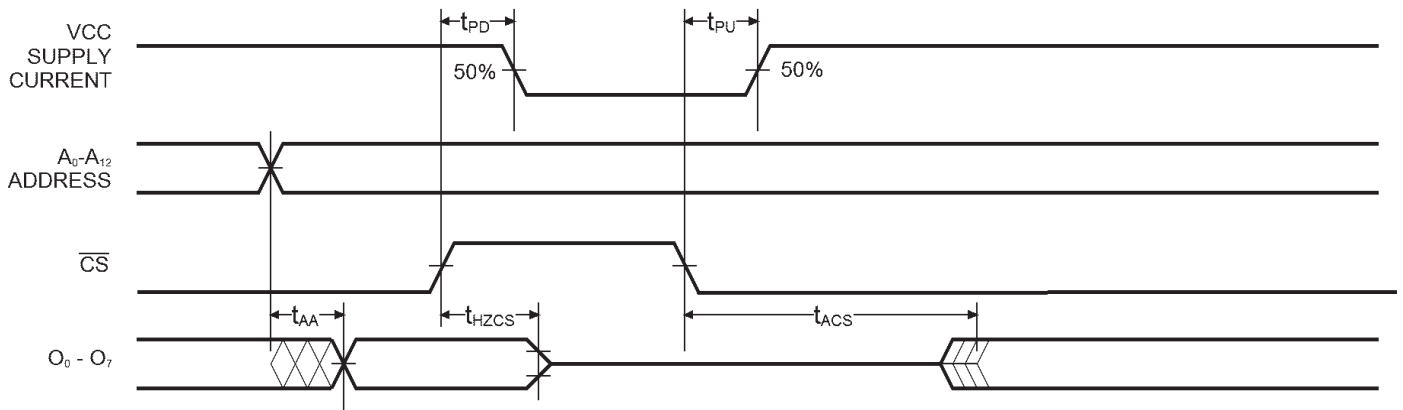

Notes:

1. Stresses greater than those listed under MAXIMUM RATINGS may cause permanent damage to the device. This is a stress rating only and functional operation of the device at these or any other conditions above those indicated in the operational sections of this specification is not implied. Exposure to MAXIMUM rating conditions for extended periods may affect reliability.
2. Extended temperature operation guaranteed with 400 linear feet per minute of air flow.
3. Transient inputs with V_{IL} and I_{IL} not more negative than $-3.0V$ and $-100mA$, respectively, are permissible for pulse widths up to 20ns.
4. This parameter is sampled and not 100% tested.



DEVICE ERASURE

If the device is subjected to wavelengths of light below 4000 Angstroms, device erasure will commence. It is therefore recommended to use an opaque label over the window in the event the device will be exposed to lighting for a long time. The UV dose for erasure requires a wavelength of 2,537 Angstroms for a minimum dose of 25 Wsec/cm². If using a UV lamp of 12 mW/cm², the exposure time is estimated to be 35 minutes. Devices should be positioned within 1 inch of the lamp during the erasure process. Permanent damage can occur to the devices if exposed to UV light for an extended period of time.

READ MODE

Reading the addressed content is the normal operating mode for a programmed device. Signals are at normal TTL levels. Addressing is applied to the 13 address pins and \overline{CS} is LOW. Under these conditions, the addressed location contents are presented to the output pins.

MODE SELECTION

Mode	Pin Function							
	Read or Output Disable	A ₁₂	A ₁₁	A ₁₀	A ₉	A ₈	\overline{CS}	O ₇ -O ₀
	Program	NA	V _{PP}	LATCH	\overline{PGM}	\overline{VFY}	\overline{CS}	D ₇ -D ₀
Read		A ₁₂	A ₁₁	A ₁₀	A ₉	A ₈	V _{IL}	O ₇ -O ₀
Output Disable		A ₁₂	A ₁₁	A ₁₀	A ₉	A ₈	V _{IH}	High Z
Program		V _{ILP}	V _{PP}	V _{ILP}	V _{ILP}	V _{IHP}	V _{ILP}	D ₇ -D ₀
Program Inhibit		V _{ILP}	V _{PP}	V _{ILP}	V _{IHP}	V _{IHP}	V _{ILP}	High Z
Program Verify		V _{ILP}	V _{PP}	V _{ILP}	V _{IHP}	V _{ILP}	V _{ILP}	O ₇ -O ₀
Blank Check		V _{ILP}	V _{PP}	V _{ILP}	V _{IHP}	V _{ILP}	V _{ILP}	O ₇ -O ₀

PROGRAMMING PINOUTS

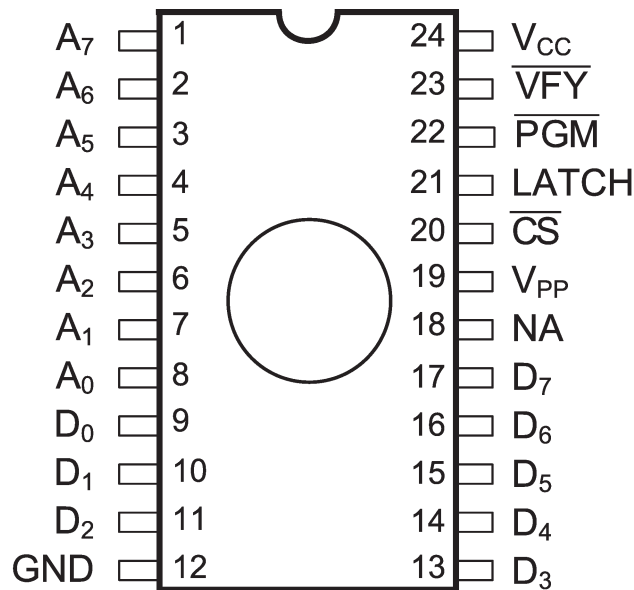



AC TEST CONDITIONS

Input Pulse Levels	GND to 3.0V
Input Rise and Fall Times	3ns
Input Timing Reference Level	1.5V
Output Timing Reference Level	1.5V
Output Load	See Figures 1 and 2

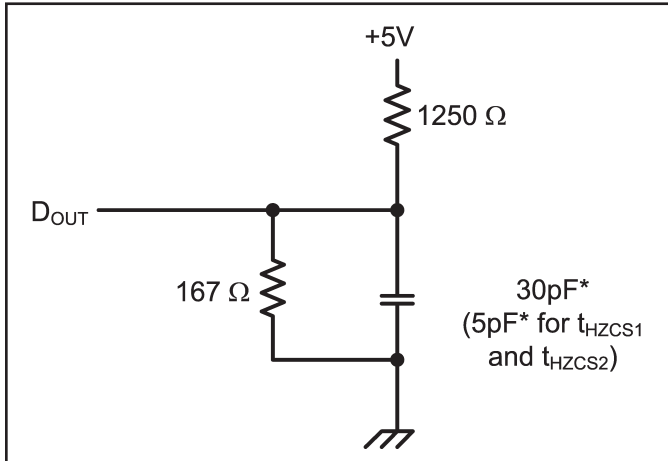

Figure 1. Output Load

* including scope and test fixture.

Note:

Because of the ultra-high speed of the PY263/PY264, care must be taken when testing this device; an inadequate setup can cause a normal functioning part to be rejected as faulty. Long high-inductance leads that

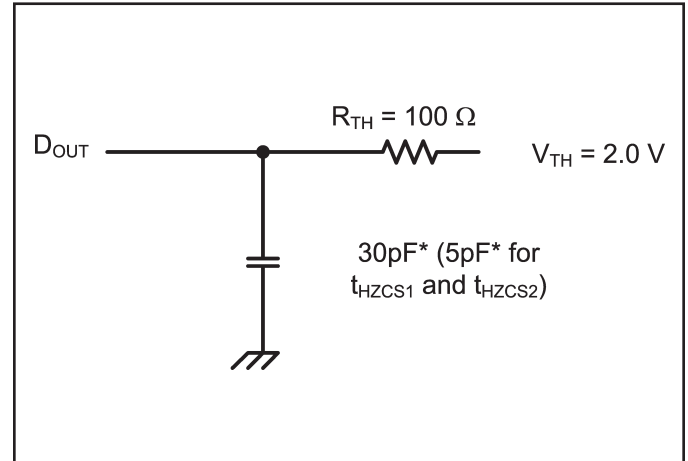
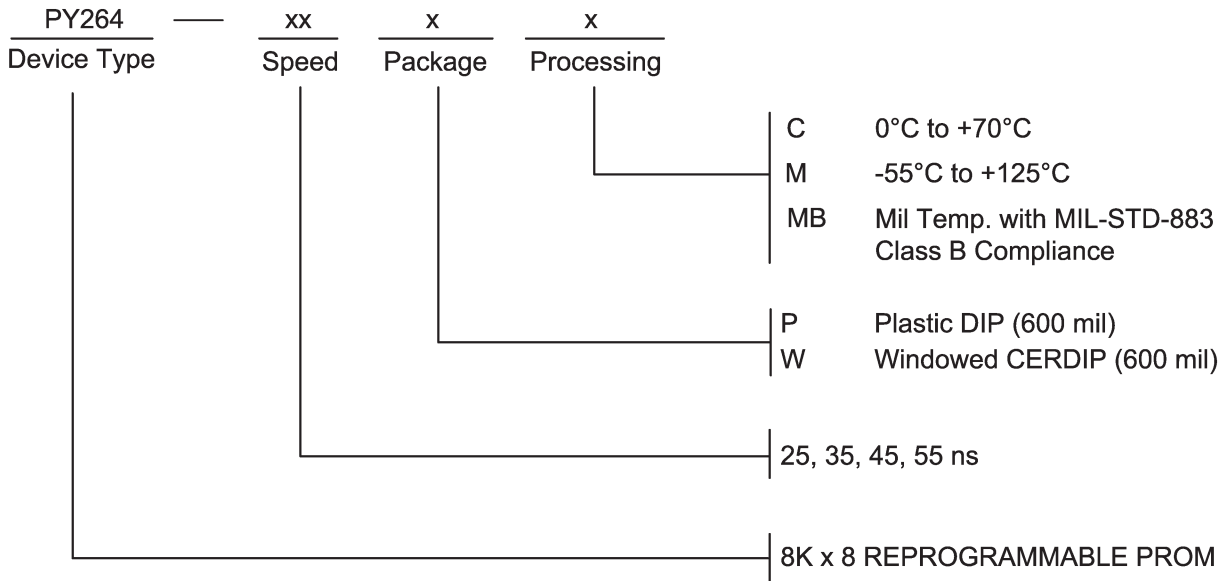
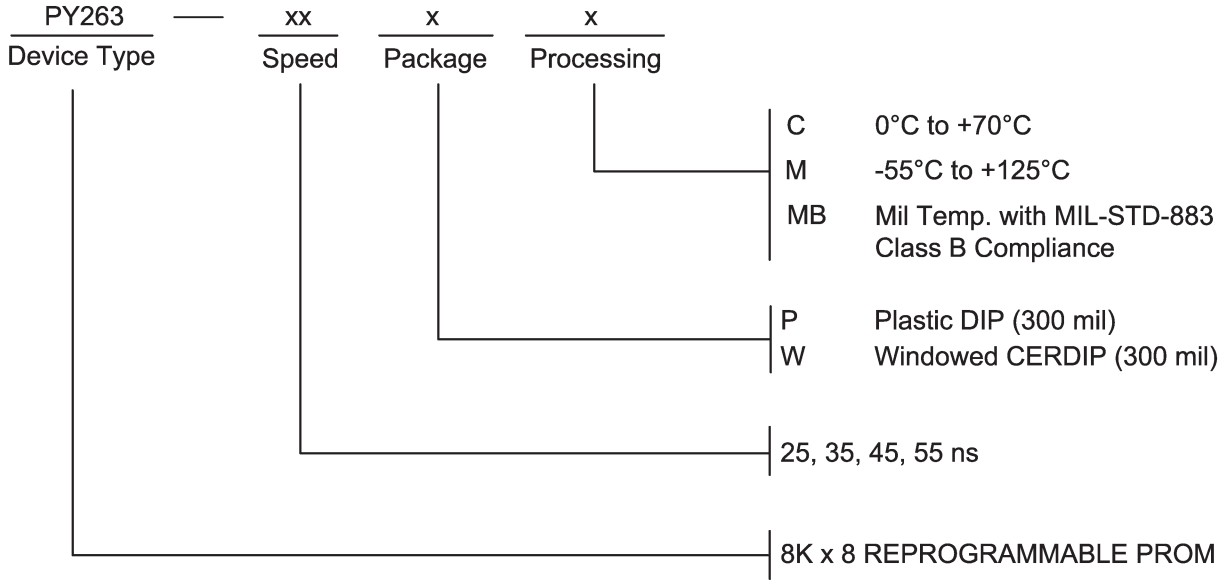

Figure 2. Thevenin Equivalent

cause supply bounce must be avoided by bringing the V_{CC} and ground planes directly up to the contactor fingers. A 0.01 μF high frequency capacitor is also required between V_{CC} and ground.



ORDERING INFORMATION





Pkg #	WD1	
# Pins	24 (300 mil)	
Symbol	Min	Max
A	-	0.200
b	0.014	0.026
b2	0.045	0.065
C	0.008	0.018
D	-	1.280
E	0.220	0.310
eA	0.300 BSC	
e	0.100 BSC	
L	0.125	0.200
Q	0.015	0.060
S1	0.005	-
α	0°	15°
WD	0.175	

CERAMIC DUAL INLINE PACKAGE (WINDOWED)

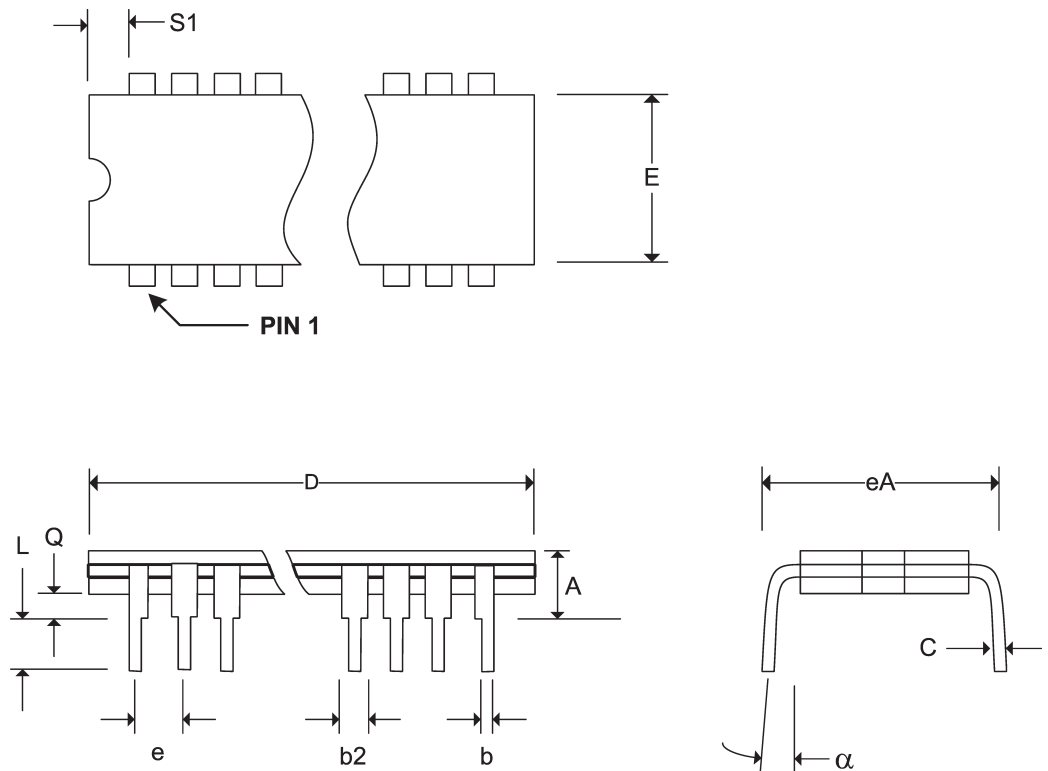

Pkg #	WD2	
# Pins	24 (600 mil)	
Symbol	Min	Max
A	0.175	0.225
b	0.015	0.020
b2	0.045	0.065
C	0.009	0.012
D	-	1.280
E	0.505	0.550
eA	0.600 BSC	
e	0.100 BSC	
L	0.125	0.200
Q	0.015	0.060
S1	0.005	-
α	0°	15°
WD	0.280	

CERAMIC DUAL INLINE PACKAGE (WINDOWED)

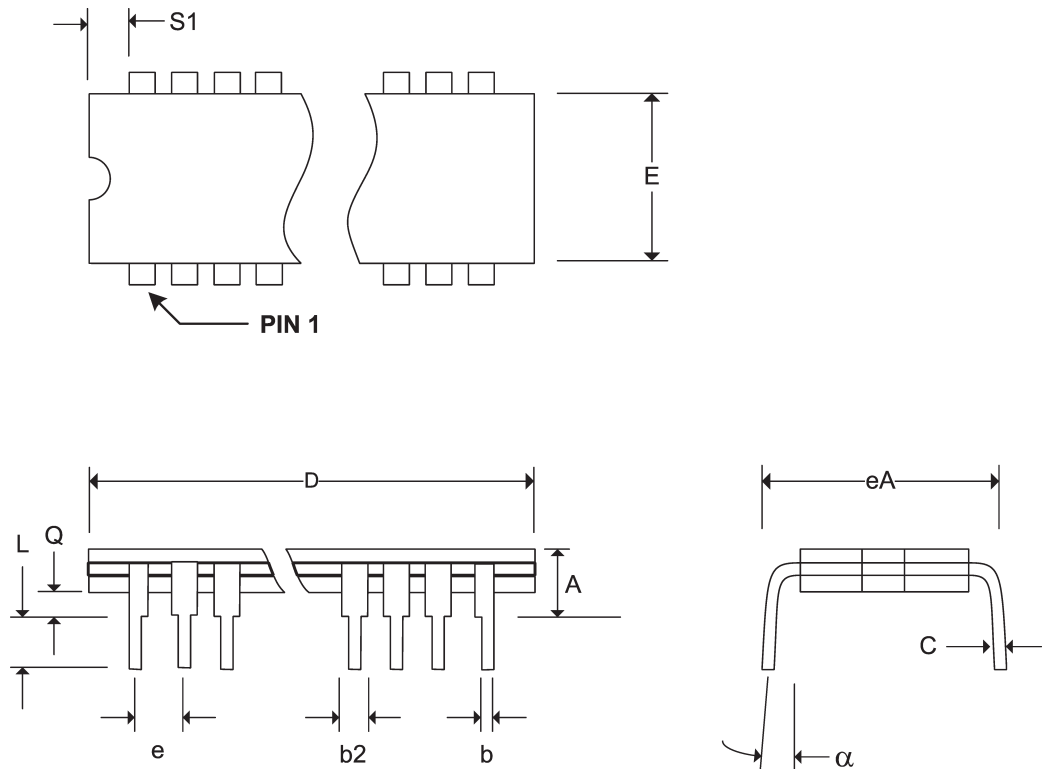



Pkg #	P4	
# Pins	24 (300 Mil)	
Symbol	Min	Max
A	-	0.210
A1	0.015	-
b	0.014	0.022
b2	0.045	0.070
C	0.008	0.014
D	1.230	1.280
E1	0.240	0.280
E	0.280	0.325
e	0.100 BSC	
eB	-	0.430
L	0.115	0.160
α	0°	15°

PLASTIC DUAL INLINE PACKAGE (NON-WINDOWED)

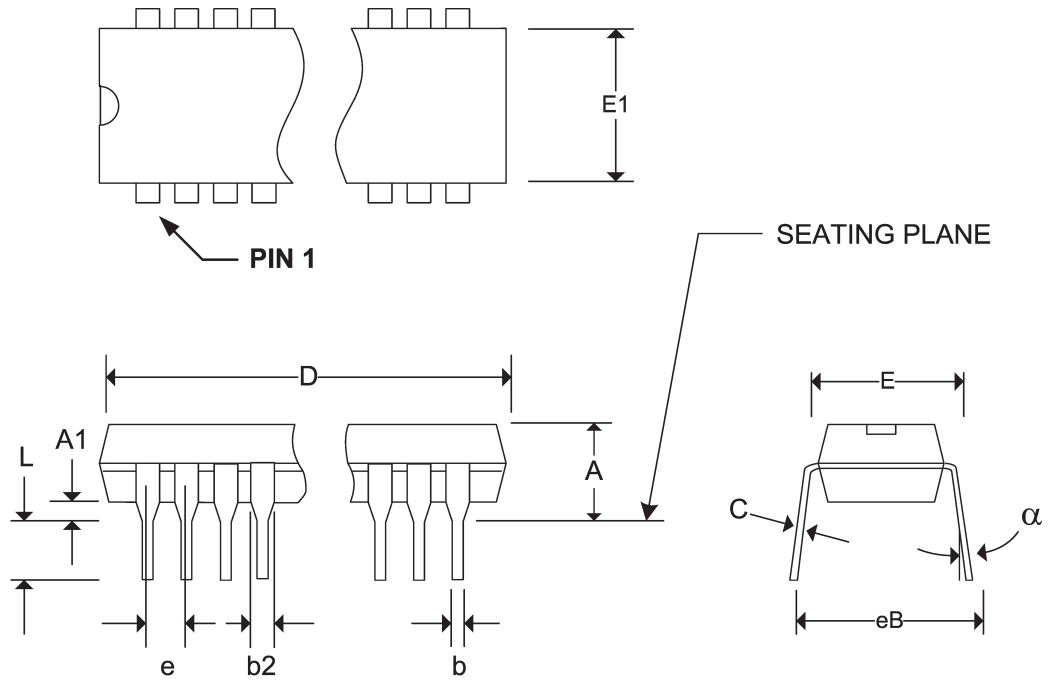

Pkg #	P8	
# Pins	24 (600 mil)	
Symbol	Min	Max
A	0.155	0.200
A1	0.015	0.060
b	0.015	0.020
b2	0.055	0.065
C	0.009	0.012
D	1.230	1.260
E1	0.530	0.550
E	0.570	0.625
e	0.100 BSC	
eB	0.610	0.685
L	0.115	0.160
α	0°	15°

PLASTIC DUAL INLINE PACKAGE (NON-WINDOWED)

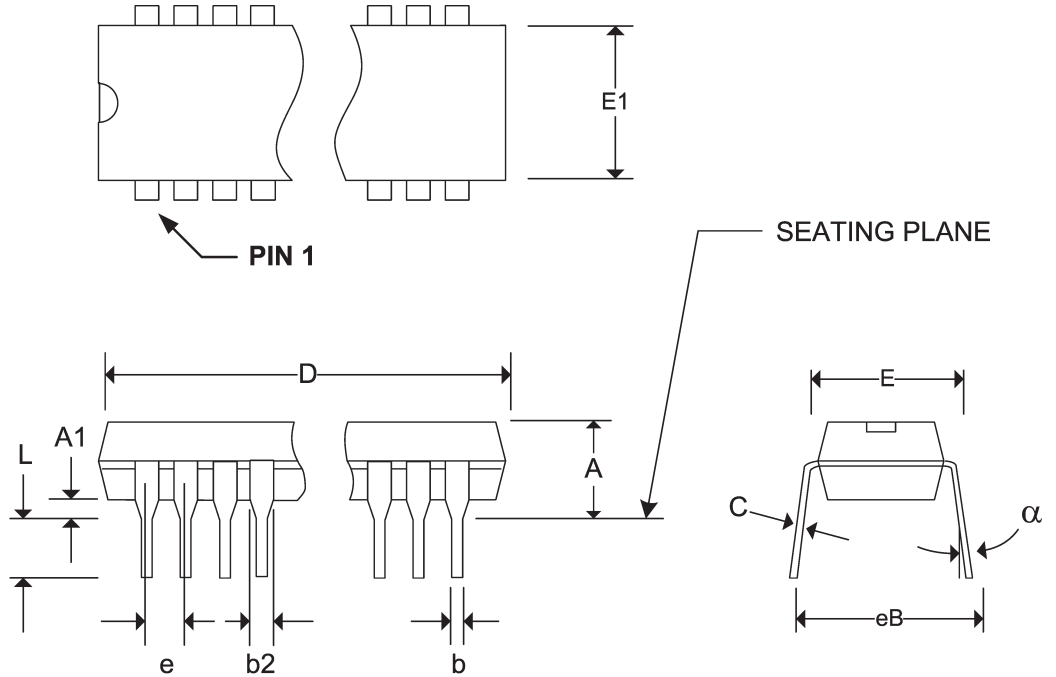

**REVISIONS**

DOCUMENT NUMBER	EPROM102
DOCUMENT TITLE	PY263 / PY264 8K X 8 PROGRAMMABLE PROM

REV	ISSUE DATE	ORIGINATOR	DESCRIPTION OF CHANGE
OR	Jul-2007	JDB	New Data Sheet
A	Mar-2009	JDB	Added PY263 (300 mil)