

# PY291A

## 2K x 8 REPROGRAMMABLE PROM



### FEATURES

- EPROM Technology for reprogramming
- High Speed
  - 20/25/35/50 ns (Commercial)
  - 25/35/50 ns (Industrial)
  - 35/50 ns (Military)
- Low Power Operation: 660 mW
- Single 5V±10% Power Supply
- Windowed devices for reprogramming
- Fully TTL Compatible Inputs and Outputs
- Standard Pinout (JEDEC Approved)
  - 24-Pin 300 mil DIP
    - Windowed Cerdip
    - Non-Windowed Cerdip
    - Non-Windowed Plastic DIP



### DESCRIPTION

The PY291A is a 2Kx8 CMOS PROM. The device is available in windowed packages which when exposed to UV light, the memory content in the PROM is erased and can be reprogrammed. EPROM technology is used in the memory cells for programming. The EPROM requires a 12.5V for programming. Devices are tested to insure that performance of the device meets the DC and AC specification limits after customer programming.

and  $CS_2$  and  $CS_3$  are HIGH. The memory contents in the address established by the Address pins ( $A_0$  to  $A_{10}$ ) will become available on the outputs ( $O_0$  to  $O_7$ ).

The PY291A is available in 24-pin 300 mil Ceramic DIPs (Cerdip, Windowed and Non-Windowed) and Plastic DIPs (Non-Windowed).

To perform a read operation from the device,  $\overline{CS}_1$  is LOW



### FUNCTIONAL BLOCK DIAGRAM

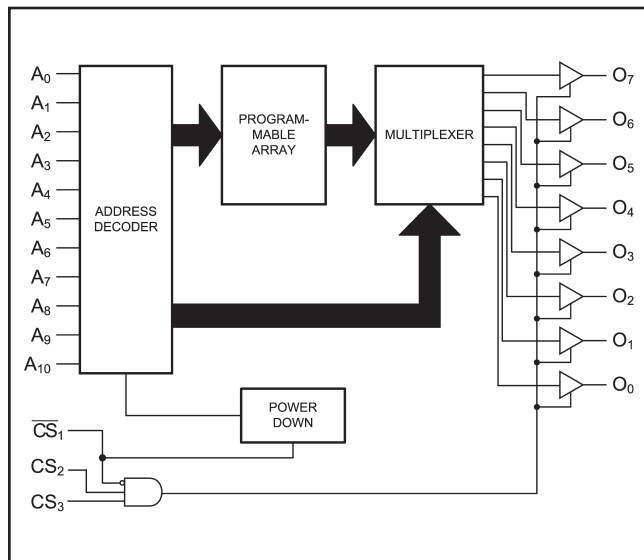

### PIN CONFIGURATION

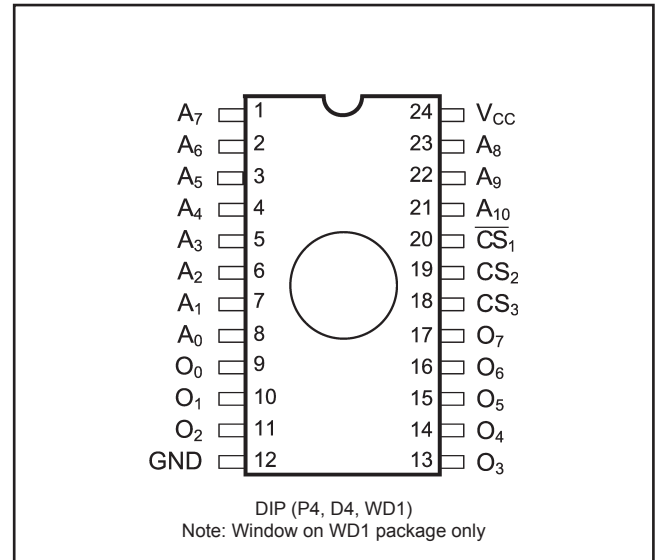

## MAXIMUM RATINGS<sup>(1)</sup>

Symbol	Parameter	Value	Unit
$V_{CC}$	Power Supply Pin with Respect to GND	-0.5 to +7	V
$V_{TERM}$	Terminal Voltage with Respect to GND (up to 7.0V)	-0.5 to $V_{CC} + 0.5$	V
$V_{PP}$	Program Voltage	13	V

Symbol	Parameter	Value	Unit
$T_A$	Operating Temperature	-55 to +125	°C
$T_{BIAS}$	Temperature Under Bias	-55 to +125	°C
$T_{STG}$	Storage Temperature	-65 to +150	°C
$P_T$	Power Dissipation	1.0	W
$I_{OUT}$	DC Output Current	50	mA

## RECOMMENDED OPERATING CONDITIONS

Grade <sup>(2)</sup>	Ambient Temp	Gnd	Vcc
Commercial	0°C to +70°C	0V	5.0V ±10%
Industrial	-40°C to +85°C	0V	5.0V ±10%
Military	-55°C to +125°C	0V	5.0V ±10%

## CAPACITANCES<sup>(4)</sup>

( $V_{CC} = 5.0V$ ,  $T_A = 25^\circ C$ ,  $f = 1.0MHz$ )

Symbol	Parameter	Conditions	Typ.	Unit
$C_{IN}$	Input Capacitance	$V_{IN} = 0V$	10	pF
$C_{OUT}$	Output Capacitance	$V_{OUT} = 0V$	10	pF

## DC ELECTRICAL CHARACTERISTICS

Over recommended operating temperature and supply voltage<sup>(2)</sup>

Symbol	Parameter	Test Conditions	PY291A		Unit
			Min	Max	
$V_{IH}$	Input High Voltage		2.0	$V_{CC}$	V
$V_{IL}$	Input Low Voltage		-0.5 <sup>(3)</sup>	0.8	V
$V_{HC}$	CMOS Input High Voltage		$V_{CC} - 0.2$	$V_{CC} + 0.5$	V
$V_{LC}$	CMOS Input Low Voltage		-0.5 <sup>(3)</sup>	0.2	V
$V_{OL}$	Output Low Voltage (TTL Load)	$I_{OL} = +16\text{ mA}$ , $V_{CC} = \text{Min.}$		0.4	V
$V_{OH}$	Output High Voltage (TTL Load)	$I_{OH} = -4\text{ mA}$ , $V_{CC} = \text{Min.}$	2.4		V
$I_{LI}$	Input Leakage Current	$V_{CC} = \text{Max.}$ $V_{IN} = \text{GND to } V_{CC}$	-10	+10	µA
$I_{LO}$	Output Leakage Current	$V_{CC} = \text{Max.}$ , $\overline{CE} = V_{IH}$ , $V_{OUT} = \text{GND to } V_{CC}$	-10	+10	µA
$V_{PP}$	Programming Supply Voltage		12	13	V
$I_{PP}$	Programming Supply Current			50	mA
$V_{IHP}$	Input HIGH Programming Voltage		3.0		V
$V_{ILP}$	Input LOW Programming Voltage			0.4	V

## POWER DISSIPATION CHARACTERISTICS VS. SPEED

Symbol	Parameter	Temperature Range	-20	-25	-35	-50	Unit
$I_{CC}$	Dynamic Operating Current*	Commercial	120	90	90	90	mA
		Industrial	N/A	90	90	90	mA
		Military	N/A	N/A	90	90	mA

**AC ELECTRICAL CHARACTERISTICS—READ CYCLE** $(V_{CC} = 5V \pm 10\%$ , All Temperature Ranges)<sup>(2)</sup>

Symbol	Parameter	-20		-25		-35		-50		Unit
		Min	Max	Min	Max	Min	Max	Min	Max	
$t_{AA}$	Address to Output Valid		20		25		35		50	ns
$t_{HZCS1}$	Chip Select Inactive to High Z		15		15		20		20	ns
$t_{ACS1}$	Chip Select Active to Output Valid		15		15		20		20	ns
$t_{HZCS2}$	Chip Select Inactive to High Z		22		27		35		45	ns
$t_{ACS2}$	Chip Select Active to Output Valid		22		27		35		45	ns
$t_{PU}$	Chip Select Active to Power-Up	0		0		0		0		ns
$t_{PD}$	Chip Slect Inactive to Power-Down		22		27		35		45	ns

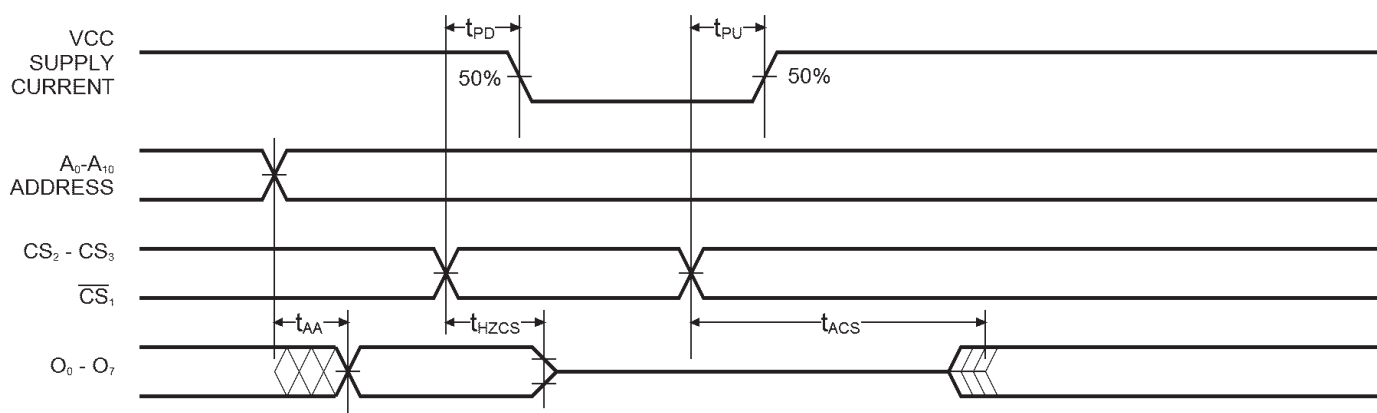
**TIMING WAVEFORM OF READ CYCLE****Notes:**

- Stresses greater than those listed under MAXIMUM RATINGS may cause permanent damage to the device. This is a stress rating only and functional operation of the device at these or any other conditions above those indicated in the operational sections of this specification is not implied. Exposure to MAXIMUM rating conditions for extended periods may affect reliability.
- Extended temperature operation guaranteed with 400 linear feet per minute of air flow.
- Transient inputs with  $V_{IL}$  and  $I_{IL}$  not more negative than  $-3.0V$  and  $-100mA$ , respectively, are permissible for pulse widths up to 20 ns.
- This parameter is sampled and not 100% tested.

## DEVICE ERASURE

If the device is subjected to wavelengths of light below 4000 Angstroms, device erasure will commence. It is therefore recommended to use an opaque label over the window in the event the device will be exposed to lighting for a long time. The UV dose for erasure requires a wavelength of 2,537 Angstroms for a minimum dose

of 25 Wsec/cm<sup>2</sup>. If using a UV lamp of 12 mW/cm<sup>2</sup>, the exposure time is estimated to be 35 minutes. Devices should be positioned within 1 inch of the lamp during the erasure process. Permanent damage can occur to the devices if exposed to UV light for an extended period of time.

## MODE SELECTION

Mode	Pin Function					
	Read or Output Disable	A <sub>10</sub> -A <sub>0</sub>	CS <sub>3</sub>	CS <sub>2</sub>	$\overline{CS}_1$	O <sub>7</sub> -O <sub>0</sub>
	Other	A <sub>10</sub> -A <sub>0</sub>	$\overline{PGM}$	$\overline{VFY}$	V <sub>PP</sub>	D <sub>7</sub> -D <sub>0</sub>
Read		A <sub>10</sub> -A <sub>0</sub>	V <sub>IH</sub>	V <sub>IH</sub>	V <sub>IL</sub>	O <sub>7</sub> -O <sub>0</sub>
Output Disable		A <sub>10</sub> -A <sub>0</sub>	X	X	V <sub>IH</sub>	High Z
Output Disable		A <sub>10</sub> -A <sub>0</sub>	X	V <sub>IL</sub>	X	High Z
Output Disable		A <sub>10</sub> -A <sub>0</sub>	V <sub>IL</sub>	X	X	High Z
Program		A <sub>10</sub> -A <sub>0</sub>	V <sub>ILP</sub>	V <sub>IHP</sub>	V <sub>PP</sub>	D <sub>7</sub> -D <sub>0</sub>
Program Verify		A <sub>10</sub> -A <sub>0</sub>	V <sub>IHP</sub>	V <sub>ILP</sub>	V <sub>PP</sub>	O <sub>7</sub> -O <sub>0</sub>
Program Inhibit		A <sub>10</sub> -A <sub>0</sub>	V <sub>IHP</sub>	V <sub>IHP</sub>	V <sub>PP</sub>	High Z
Intelligent Program		A <sub>10</sub> -A <sub>0</sub>	V <sub>ILP</sub>	V <sub>IHP</sub>	V <sub>PP</sub>	D <sub>7</sub> -D <sub>0</sub>
Blank Check Zeros		A <sub>10</sub> -A <sub>0</sub>	V <sub>IHP</sub>	V <sub>ILP</sub>	V <sub>PP</sub>	Zeros

X = Don't Care

## PROGRAMMING PINOUTS

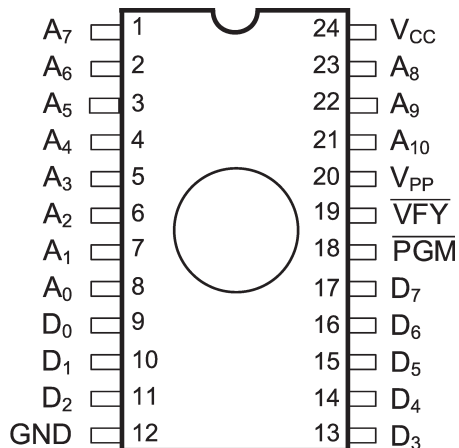

## AC TEST CONDITIONS

Input Pulse Levels	GND to 3.0V
Input Rise and Fall Times	3ns
Input Timing Reference Level	1.5V
Output Timing Reference Level	1.5V
Output Load	See Figures 1 and 2

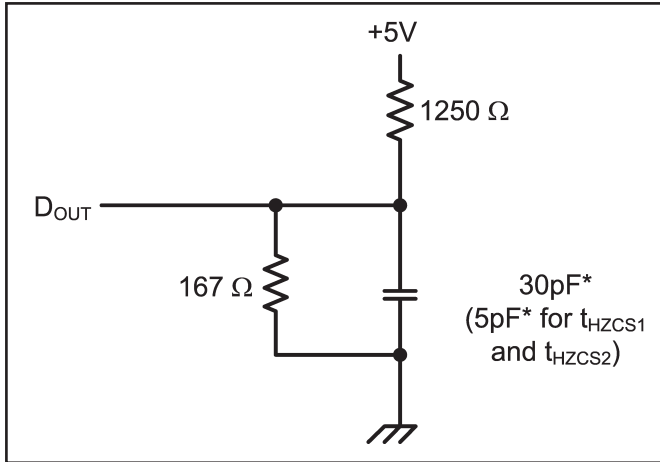

Figure 1. Output Load

\* including scope and test fixture.

**Note:**

Because of the ultra-high speed of the PY291A, care must be taken when testing this device; an inadequate setup can cause a normal functioning part to be rejected as faulty. Long high-inductance leads that cause

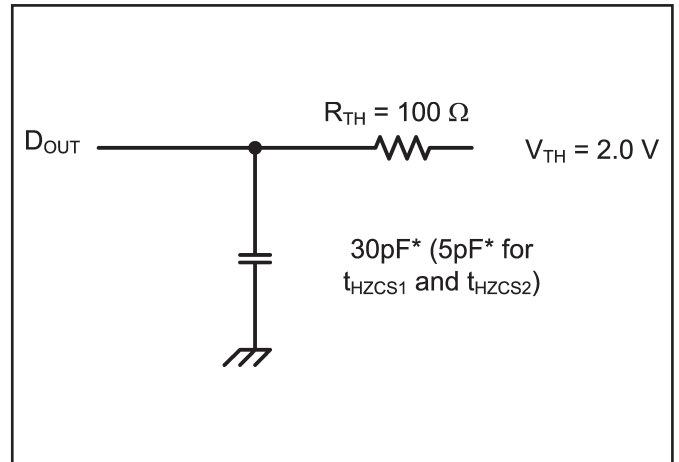
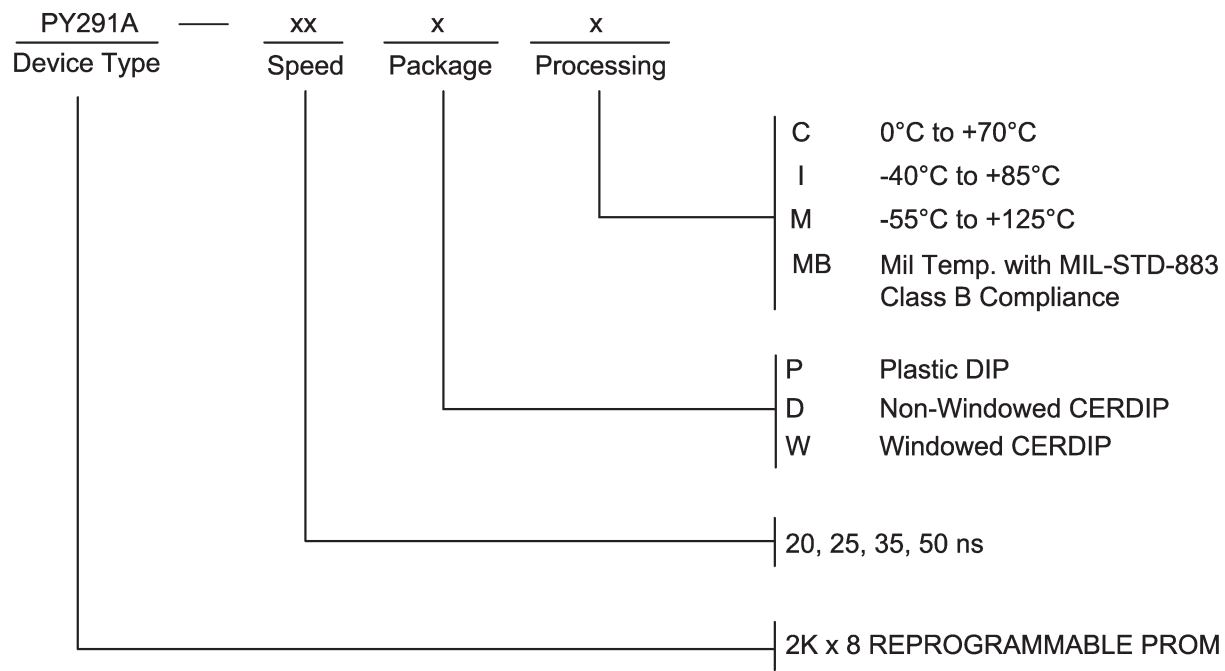

Figure 2. Thevenin Equivalent

supply bounce must be avoided by bringing the  $V_{CC}$  and ground planes directly up to the contactor fingers. A 0.01  $\mu$ F high frequency capacitor is also required between  $V_{CC}$  and ground.

## ORDERING INFORMATION



Pkg #	D4	
# Pins	24 (300 mil)	
Symbol	Min	Max
A	-	0.200
b	0.014	0.026
b2	0.045	0.065
C	0.008	0.018
D	-	1.280
E	0.220	0.310
eA	0.300 BSC	
e	0.100 BSC	
L	0.125	0.200
Q	0.015	0.060
S1	0.005	-
$\alpha$	0°	15°

**CERAMIC DUAL IN-LINE PACKAGE (NON-WINDOWED)**

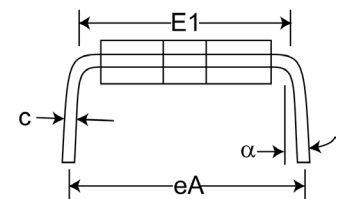
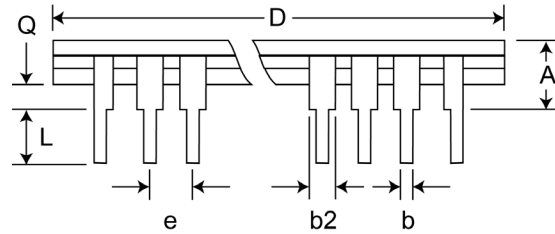
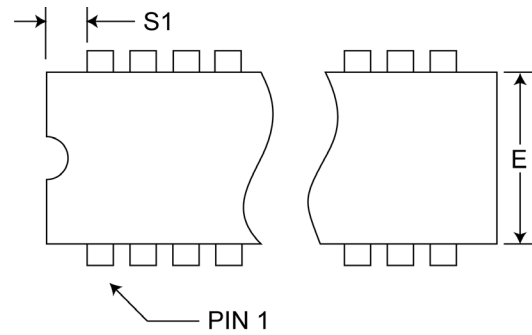

Pkg #	WD1	
# Pins	24 (300 mil)	
Symbol	Min	Max
A	-	0.200
b	0.014	0.026
b2	0.045	0.065
C	0.008	0.018
D	-	1.280
E	0.220	0.310
eA	0.300 BSC	
e	0.100 BSC	
L	0.125	0.200
Q	0.015	0.060
S1	0.005	-
$\alpha$	0°	15°
WD	0.175	

**CERAMIC DUAL IN-LINE PACKAGE (WINDOWED)**

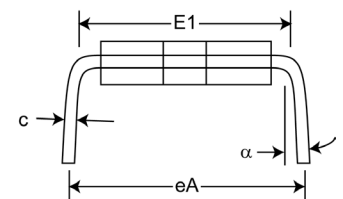
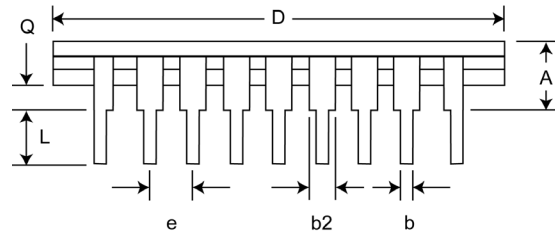
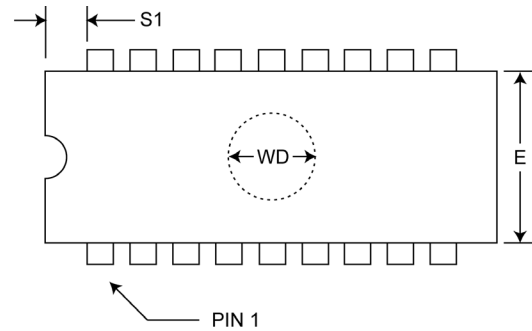

Pkg #	P4	
# Pins	24 (300 Mil)	
Symbol	Min	Max
A	-	0.210
A1	0.015	-
b	0.014	0.022
b2	0.045	0.070
C	0.008	0.014
D	1.230	1.280
E1	0.240	0.280
E	0.280	0.325
e	0.100 BSC	
eB	-	0.430
L	0.115	0.160
$\alpha$	0°	15°

**PLASTIC DUAL IN-LINE PACKAGE**

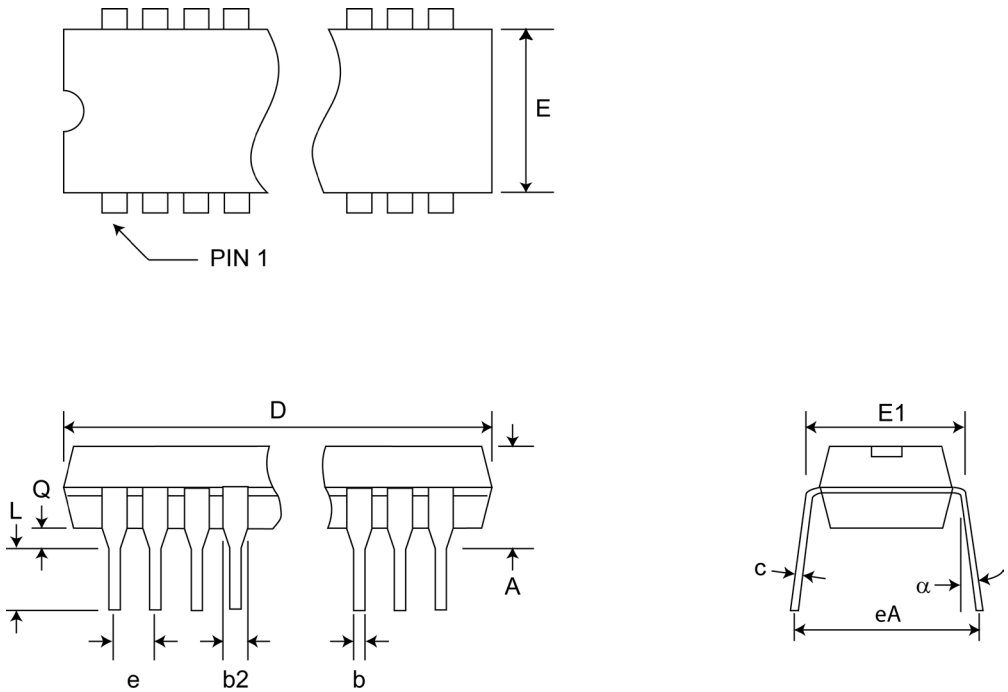

**REVISIONS**

<b>DOCUMENT NUMBER</b>	EPROM101
<b>DOCUMENT TITLE</b>	PY291A 2K x 8 REPROGRAMMABLE PROM

<b>REV</b>	<b>ISSUE DATE</b>	<b>ORIGINATOR</b>	<b>DESCRIPTION OF CHANGE</b>
OR	Jun-2007	JDB	New Data Sheet
01	Mar-2010	JDB	Added Industrial Temperature Range