

P1750AE/SOS SINGLE CHIP, 30MHz, ENHANCED SPACE PROCESSOR



FEATURES

- Implements the MIL-STD-1750A Instruction Set Architecture
- Single Chip MIL-STD-1750AE Processor
- Form-Fit-Functionally Compatible with the P1750A CMOS Processor
- DAIS Instruction Mix Execution Performance Including Floating Point Arithmetic
 - 1.8 MIPS at 20 MHz
 - 2.25 MIPS at 25 MHz
 - 2.7 MIPS at 30 MHz
- BIF Instructions Allow for High Throughput Implementations of Transcendental Functions, Navigational Algorithms, and DSP Functions
- 20, 25 and 30 MHz Operation over the Military Temperature Range (-55 to +125°C)
- Extensive Error and Fault Management and Interrupt Handling Capability. Built in Self Test.
- Two programmable Timers
- 26 User Accessible Registers
- TTL Signal Level Compatible Inputs and Outputs
- Single 5V ± 10% Power Supply
- Multiprocessor and Co-processor Capability
- Available in:
 - - 68-Lead Quad Pack (Leaded Chip Carrier)
 - Space Radiation Tolerant
 - Absolute latch up immunity
 - Total Dose: > 100K Rad/Si
 - SEU Tolerance < 10⁻¹⁰ errors per day



GENERAL DESCRIPTION

The P1750AE/SOS is a general purpose, single chip, 16-bit CMOS/SOS microprocessor designed for high performance floating point and integer arithmetic, with extensive real time environment support. It offers a variety of data types, including bits, bytes, 16-bit and 32-bit integers, and 32-bit and 48-bit floating point numbers. It provides 13 addressing modes, including direct, indirect, indexed, based, based indexed and immediate long and short, and it can access 2 MWords memory.

The P1750AE/SOS offers a well-rounded instruction set with 130 instruction types, including a comprehensive integer, floating point, integer-to-floating point and floating point-to-integer set, a variety of stack manipulation instructions, high level language support instructions such as Compare Between Bounds and Loop Control Instructions. It also offers some unique instructions such as vectored I/O, as well as supports executive and user modes, and provides an escape mechanism which allows

user-defined instructions, using a coprocessor.

The chip includes an array of real time application support resources, such as 2 programmable timers, a complete interrupt controller supporting 16 levels of prioritized internal and external interrupts, and a faults and exceptions handler controlling internally and externally generated faults.

The P1750AE/SOS uses a single multiplexed 16-bit parallel bus. Status signals are provided to determine whether the processor is in the memory or I/O bus cycle, reading and writing, and whether the bus cycle is for data or instructions.

The P1750AE/SOS is fabricated using insulated substrate silicon on sapphire technology to provide absolute immunity from destructive latch up caused by natural space radiation as well as increased total dose and SEU tolerance.

P1750A, P1750A/SOS, P1750AE, & P1750AE/SOS PROCESSORS

Pyramid Semiconductor offers four single chip MIL-STD-1750A Processors. Two of these processors, the P1750A and the P1750AE are manufactured with industry standard CMOS Technology. The P1750A/SOS and the P1750AE/SOS are derivatives of the P1750A and P1750AE and are manufactured with insulated substrate Silicon on Sapphire, CMOS/SOS Technology to provide absolute immunity from destructive latch up caused by the exposure of a space vehicle to natural space radiation.

The P1750AE is architecturally more efficient than the P1750A and provides higher throughput at the same clock frequency. All four processors are mechanically interchangeable, they have the same pinouts. The processors are electrically interchangeable as long as the specification limits for the slowest processor in the interchangeability matrix are not violated. All four processors are stand alone single chip, fully compliant MIL-STD-1750A Processors.

The P1750AE is a second generation MIL-STD-1750A Processor that has been designed as a direct ("plug in") electrical, mechanical, and software compatible replacement for the P1750A. The P1750A and the P1750AE are also proven replacements for other MIL-STD-1750A Processors that are no longer available. The P1750AE has been application proven in a number of critical applications aboard a wide range of platforms including combat aircraft, helicopters, submarines, surface vehicles, and satellites. The P1750AE operates the MIL-STD-1750A Instruction Set in fewer "clocks" than the P1750A. Depending upon the number of arithmetic instructions used, the P1750AE can easily provide more than 3X the throughput of the P1750A at the same clock frequency with the same operational software; see Tables 1 and 2. The P1750A and P1750AE have the same bus cycle. Basic execution instructions such as add/subtract, set/test/reset bit, load & store, byte manipulation, logical OR/NAND/AND, etc. all execute with the same number of "clocks" in both the P1750A and P1750AE. The standard CMOS P1750A and P1750AE are specified by DSCC SMD 5962-87665.

The P1750A/SOS and P1750AE/SOS are derivatives of the P1750A and P1750AE. These SOS processors are targeted for use aboard space vehicles and are manufactured with insulated substrate Silicon on Sapphire (SOS) Technology so as to provide high tolerance to the natural space radiation environment which can degrade or destroy standard CMOS Technology processors. The space radiation tolerance for the P1750AE/SOS is shown in Table 4. The P1750A/SOS is interchangeable with the P1750A and the P1750AE/SOS is interchangeable with the P1750AE provided that the electrical specifications for

the SOS Processor are utilized in the design. Processors manufactured with SOS Technology have higher power requirements and, for some signals, longer delays than the standard CMOS Processors. However, both the CMOS and CMOS/SOS Processors operate the MIL-STD-1750A Instructions with the same number of clocks.

In space, CMOS/SOS provides absolute immunity from destructive Single Event Latchup which can occur when high energy ionizing particles, found naturally in space, enter the space craft when passing through an integrated circuit, these particles introduce enough charge in standard CMOS devices to cause a destructive internal short circuit from the device power supply through the standard CMOS substrate to ground. This latchup current can be more than the integrated circuit can safely carry and the device is either severely weakened reducing its operational life time or is immediately destroyed.

DIFFERENCES BETWEEN THE P1750A AND P1750AE

The P1750AE achieves a 40% boost in performance (in clock cycles) over the P1750A. This reduction in clocks per instruction is because of three architectural enhancements:

- 1) The inclusion of a 24 x 24 Multiply Accumulate (MAC) array.
- 2) A reduction in non-bus cycles to 2 clocks (bus cycles remain at 4 clocks to maintain full compatibility with the CPU's peripheral chips).
- 3) Branch calculation logic.

Table 1. P1750A vs. P1750AE
of "Clocks" Required to Execute Selected Instructions

Instruction	P1750A # of Clocks	P1750AE # of Clocks	Throughput Increase ⁽¹⁾
Integer Multiply	23	4	5.75
Compare Between Limits	24	20	1.2
Flt. Point Add/Subtract	28	18	1.56
Flt. Point Multiply	43	9	4.78
Flt. Point Compare	6	4	1.5
Convert Flt. Point To Integer	22	16	1.38
Shift Logical Left/Right	9	6	1.5
Exchange	6	4	1.5
Branch	12	8	1.5

Note:

1. Number of P1750A Clocks divided by number of P1750AE Clocks.

Table 2. P1750AE BUILT-IN FUNCTIONS

A core set of additional instructions has been included in the PACE1750AE. These instructions utilize the Built-In Function (BIF) opcode space. The objective of these new opcodes is to enhance the performance of the 1750AE in critical application areas such as navigation, DSP, transcendentals, and other LINPAK and matrix instructions. Below is a list of the BIFs and their execution times (N = the number of elements in the vector being processed).

Instruction	Mnemonic	Address Mode	Number of Clocks	Notes
Memory Parametric Dot Product - Single	VDPS	4F3(RA)	$10+8^N$	Interruptable
Memory Parametric Dot Product - Double	VDPD	4F1(RA)	$10+16^N$	Interruptable
3 x 3 Register Dot Product	R3DP	4F03	6	
Double Precision Multiply Accumulate	MACD	4F02	8	
Polynomial	POLY	4F06	7^{N-2}	
Clear Accumulator	CLAC	4F00	4	
Store Accumulator (32-Bit)	STA	4F08	7	
Store Accumulator (48-Bit)	STAL	4F04	11	
Load Accumulator (32-Bit)	LAC	4F05	9	
Load Accumulator Long (48-Bit)	LACL	4F07	9	
Move MMU Page Block	MMPG	4F0F	$16+8^N$	Privileged
Load Timer A Reset Register	LTAR	4F0D	4	
Load Timer B Reset Register	LTBR	4F0E	4	

ABSOLUTE MAXIMUM RATINGS¹

Supply Voltage Range	-0.5V to +7.0V
Input Voltage Range	-0.5V to $V_{CC} + 0.5V$
Storage Temperature Range	-65°C to +150°C
Input Current Range	-30mA to +5mA
Voltage applied to Inputs	-0.5V to $V_{CC} + 0.5V$
Current applied to Output ³	150 mA
Maximum Power Dissipation ²	1.5W

MAXIMUM CONTINUOUS OPERATING RANGE

Case Temperature	GND	V_{CC}
-55°C to +125°C	0	4.5V to +5.5V

SPACE RADIATION TOLERANCE

Requirement	Specification	Comment
Total Dose (Ionizing Radiation)	≥ 100 K Rads (Si)	MIL-STD-883TM1019 Cond. B Processor meets all data sheet specification limits following exposure to ≥ 100 K Rad (Si).
Single Event Upset (SEU)	$< 10^{-10}$ Errors per day	Adams 90% worst case cosmic Ray environment upset rate calculated with creme.
Single Event Latchup (SEL)	Absolute Immunity	CMOS/SOS Technology eliminates the latchup mechanism.

NOTES:

1. Stresses above the absolute maximum rating may cause permanent damage to the device. Extended operation at the maximum levels may degrade performance and affect reliability.
2. Must withstand the added power dissipation due to short circuit test e.g., los.
3. Duration: 1 second or less.

DC ELECTRICAL SPECIFICATIONS (Over recommended operating conditions)

Symbol	Parameter		Min	Max	Unit	Conditions ¹	
V _{IH}	Input HIGH Level Voltage		2.0	V _{CC} + 0.5	V		
V _{IL}	Input LOW Level Voltage ²		-0.5	0.8	V		
V _{OH}	Output HIGH Level Voltage		2.4		V	V _{CC} = 4.5V	I _{OH} = -8.0mA
			V _{CC} - 0.2		V	V _{CC} = 4.5V	I _{OH} = -300μA
V _{OL}	Output LOW Level Voltage			0.5	V	V _{CC} = 4.5V	I _{OL} = 8.0mA
				0.2	V	V _{CC} = 4.5V	I _{OL} = 300μA
I _{IH1}	Input HIGH Level Current, except I _{B0} - I _{B15} , $\overline{\text{BUS BUSY}}$, $\overline{\text{BUS LOCK}}$			100	μA	V _{IN} = V _{CC} , V _{CC} = 5.5V	
I _{IH2}	Input HIGH Level Current, I _{B0} - I _{B15} , $\overline{\text{BUS BUSY}}$, $\overline{\text{BUS LOCK}}$			100	μA	V _{IN} = V _{CC} , V _{CC} = 5.5V	
I _{IL1}	Input LOW Level Current, except I _{B0} - I _{B15} , $\overline{\text{BUS BUSY}}$, $\overline{\text{BUS LOCK}}$			-50	μA	V _{IN} = GND, V _{CC} = 5.5V	
I _{IL2}	Input LOW Level Current, I _{B0} - I _{B15} , $\overline{\text{BUS BUSY}}$, $\overline{\text{BUS LOCK}}$			-50	μA	V _{IN} = GND, V _{CC} = 5.5V	
I _{OZH}	Output Three-State Current			50	μA	V _{OUT} = 2.4V, V _{CC} = 5.5V	
I _{OZL}	Output Three-State Current			-50	μA	V _{OUT} = 0.5V, V _{CC} = 5.5V	
I _{CCQC}	Quiescent Power Supply Current (CMOS Input Levels)			25	mA	V _{IN} < 0.2V or < V _{CC} - 0.2V, f = 0MHz, Outputs Open, V _{CC} = 5.5V	
I _{CCQT}	Quiescent Power Supply Current (TTL Input Levels)			100	mA	V _{IN} < 3.4V, f = 0MHz, Outputs Open, V _{CC} = 5.5V	
I _{CCD}	Dynamic Power Supply Current	20 MHz		140	mA	V _{IN} = 0V to V _{CC} , tr = tf = 2.5 ns, Outputs Open,	
		25 MHz		150	mA	V _{CC} = 5.5V	
		30 MHz		160	mA		
I _{OS}	Output Short Circuit Current ³		-25		mA	V _{OUT} = GND, V _{CC} = 5.5V	
C _{IN}	Input Capacitance			10	pF		
C _{OUT}	Output Capacitance			15	pF		
C _{I/O}	Bi-directional Capacitance			15	pF		

Notes

- 4.5V ≤ V_{CC} ≤ 5.5V, -55°C ≤ T_C ≤ +125°C. Unless otherwise specified, testing shall be conducted at worst-case conditions.
- V_{IL} = -3.0V for pulse widths less than or equal to 20ns.
- Duration of the short should not exceed one second; only one output may be shorted at a time.

SIGNAL PROPAGATION DELAYS^{1,2}

Symbol	Parameter	20 MHz		25 MHz		30 MHz		Unit
		Min	Max	Min	Max	Min	Max	
$t_{C(BR)L}$	$\overline{\text{BUS REQ}}$		33		30		26	ns
$t_{C(BR)H}$	BUS REQ		33		30		26	ns
$t_{BGV(C)}$	$\overline{\text{BUS GNT}}$ setup	5		5		5		ns
$t_{C(BG)X}$	$\overline{\text{BUS GNT}}$ hold	5		5		5		ns
$t_{C(BB)L}$	$\overline{\text{BUS BUSY}}$ LOW		38		33		25	ns
$t_{C(BB)H}$	$\overline{\text{BUS BUSY}}$ HIGH		38		33		25	ns
$t_{BBV(C)}$	$\overline{\text{BUS BUSY}}$ setup	5		5		5		ns
$t_{C(BB)X}$	$\overline{\text{BUS BUSY}}$ hold	5		5		5		ns
$t_{C(BL)L}$	$\overline{\text{BUS LOCK}}$ LOW		38		34		32	ns
$t_{C(BL)H}$	$\overline{\text{BUS LOCK}}$ HIGH		34		30		32	ns
$t_{BLV(C)}$	$\overline{\text{BUS LOCK}}$ setup	5		5		5		ns
$t_{C(BL)X (IN)}$	$\overline{\text{BUS LOCK}}$ hold	5		5		5		ns
$t_{C(ST)V}$	D/ $\overline{\text{I}}$ Status, AS ₀ -AS ₃ , AK ₀ -AK ₃ , M/ $\overline{\text{I/O}}$, R/ $\overline{\text{W}}$		32		28		25	ns
			32		28		25	ns
$t_{C(ST)X}$	M/ $\overline{\text{I/O}}$, R/ $\overline{\text{W}}$, D/ $\overline{\text{I}}$ Status, AS ₀ -AS ₃ , AK ₀ -AK ₃	0		0		0		ns
$t_{C(SA)H}$	STRBA HIGH		24		20		18	ns
$t_{C(SA)L}$	STRBA LOW		24		20		18	ns
$t_{SAL(IBA)X}$	Address hold from STRBA LOW	5		5		5		ns
$t_{RAV(C)}$	RDYA setup	5		5		5		ns
$t_{C(RA)X}$	RDYA hold	5		5		5		ns
$t_{C(SDW)L}$	$\overline{\text{STRBD}}$ LOW write		24		20		18	ns
$t_{C(SD)H}$	$\overline{\text{STRBD}}$ HIGH		24		20		18	ns
$t_{FC(SDR)L}$	$\overline{\text{STRBD}}$ LOW read		24		20		18	ns
$t_{SDRH(IBD)X}$	$\overline{\text{STRBD}}$ HIGH	0		0		0		ns
$t_{SDWH(IBD)X}$	$\overline{\text{STRBD}}$ HIGH	28		27		25		ns
$t_{SDL(SD)H}$	$\overline{\text{STRBD}}$ write	28		26		24		ns
$t_{RDV(C)}$	RDYD setup	5		5		5		ns
$t_{C(RD)X}$	RDYD hold	5		5		5		ns
$t_{C(IBA)V}$	IB ₀ -IB ₁₅		36		32		28	ns
$t_{FC(IBA)X}$	IB ₀ -IB ₁₅	0		0		0		ns
$t_{IBDRV(C)}$	IB ₀ -IB ₁₅ setup	5		5		5		ns
$t_{C(IBD)X}$	IB ₀ -IB ₁₅ hold (read)	5		5		5		ns
$t_{C(IBD)X}$	Data valid out (write)	0		0		0		ns

SIGNAL PROPAGATION DELAYS^{1,2} (continued)

Symbol	Parameter	20 MHz		25 MHz		30 MHz		Unit
		Min	Max	Min	Max	Min	Max	
$t_{FC(IBD)V}$	IB ₀ -IB ₁₅		38		34		32	ns
$t_{C(SNW)}$	SNEW		34		30		28	ns
$t_{FC(TGO)}$	$\overline{TRIGO RST}$		34		30		28	ns
$t_{RSTL(DMA ENL)}$	DMA enable		44		40		38	ns
$t_{C(DME)}$	DMA enable		44		40		38	ns
$t_{FC(NPU)}$	Normal power up		44		40		38	ns
$t_{C(ER)}$	Clock to major error unrecoverable		60		55		52	ns
$t_{RSTL(NPU)}$	\overline{RESET}		50		45		40	ns
$t_{REQV(C)}$	Console request	0		0		0		ns
$t_{C(REQ)X}$	Console request	15		15		15		ns
$t_{FV(BB)H}$	Level sensitive faults	5		5		5		ns
$t_{BBH(F)X}$	Level sensitive faults	5		5		5		ns
$t_{IRV(C)}$	IOL _{1,2} INT user interrupt (0-5) setup	0		0		0		ns
$t_{C(IR)X}$	Power down interrupt level sensitive hold	15		15		15		ns
$t_{RSTL} (t_{RSTH})$	Reset pulse width	25		25		20		ns
$t_{C(XX)Z}$	Clock to three-state		24		20		18	ns
$t_{f(F)}, t_{1(1)}$	Edge sensitive pulse width	5		5		5		ns
t_r, t_f	Clock rise and fall		5		4		3	ns

Notes

1. $4.5V \leq V_{CC} \leq 5.5V$, $-55^{\circ}C \leq T_C \leq +125^{\circ}C$. Unless otherwise specified, testing shall be conducted at worst-case conditions.
2. All timing parameters are composed of Three elements. The first "t" stands for timing. The second represents the "from" signal. The third in parentheses indicates "to" signal. When the CPU clock is one of the signal elements, either the rising edge "C" or the falling edge "FC" is referenced. When other elements are used, an additional suffix indicates the final logic level of the signal. "L" - low level, "H" - high level, "V" - valid, "Z" - high impedance, "X" - don't care, "LH" - low to high, "ZH" - high impedance to high, "R" - read cycle, and "W" - write cycle.
3. Functional test shall consist of the same functional test patterns used when testing the equivalent standard CMOS SMD 5962-87665 processor.

MINIMUM WRITE BUS CYCLE TIMING DIAGRAM

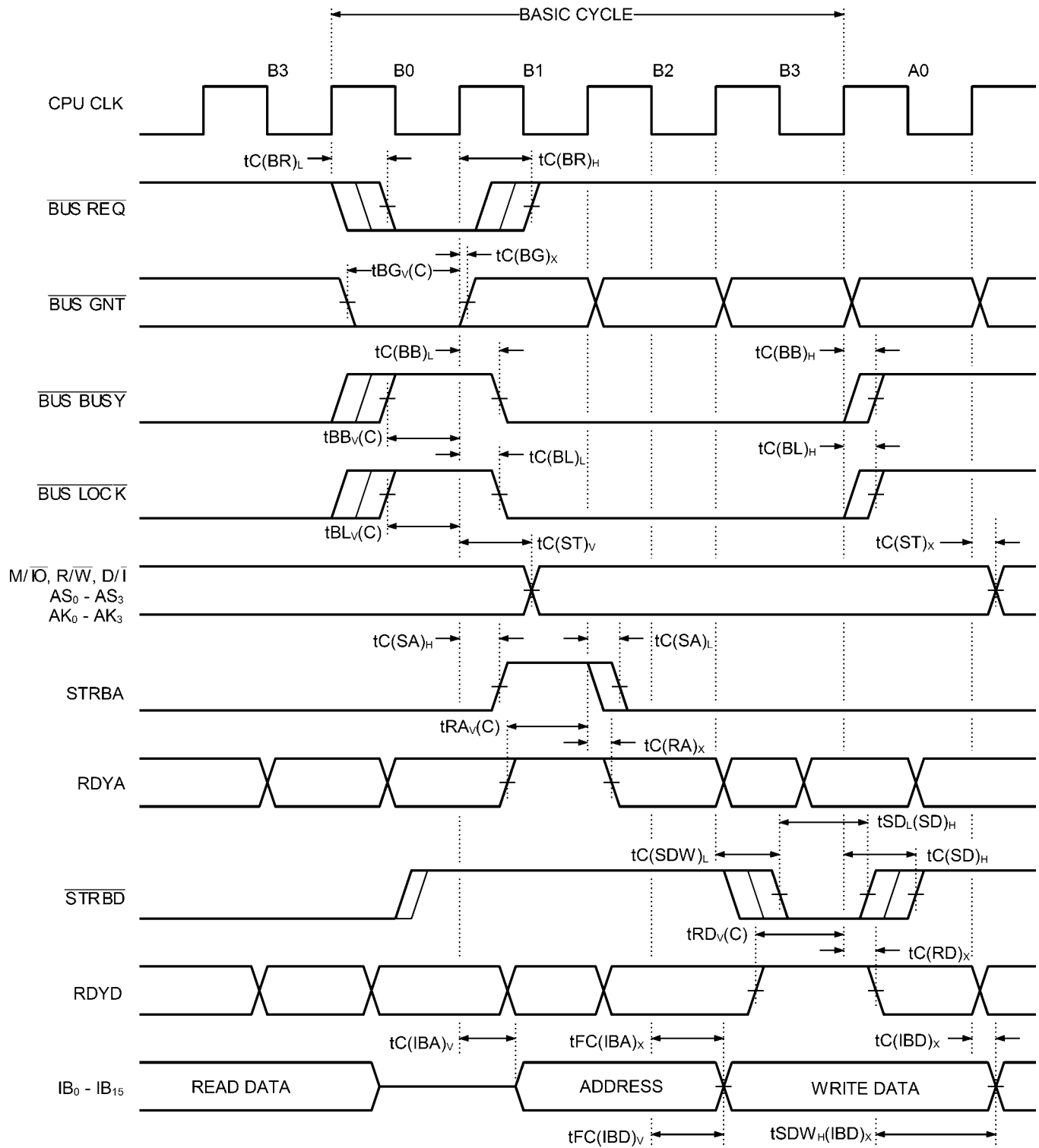

Note:
All time measurements on active signals relate to the 1.5 volt level.

MINIMUM READ BUS CYCLE TIMING DIAGRAM

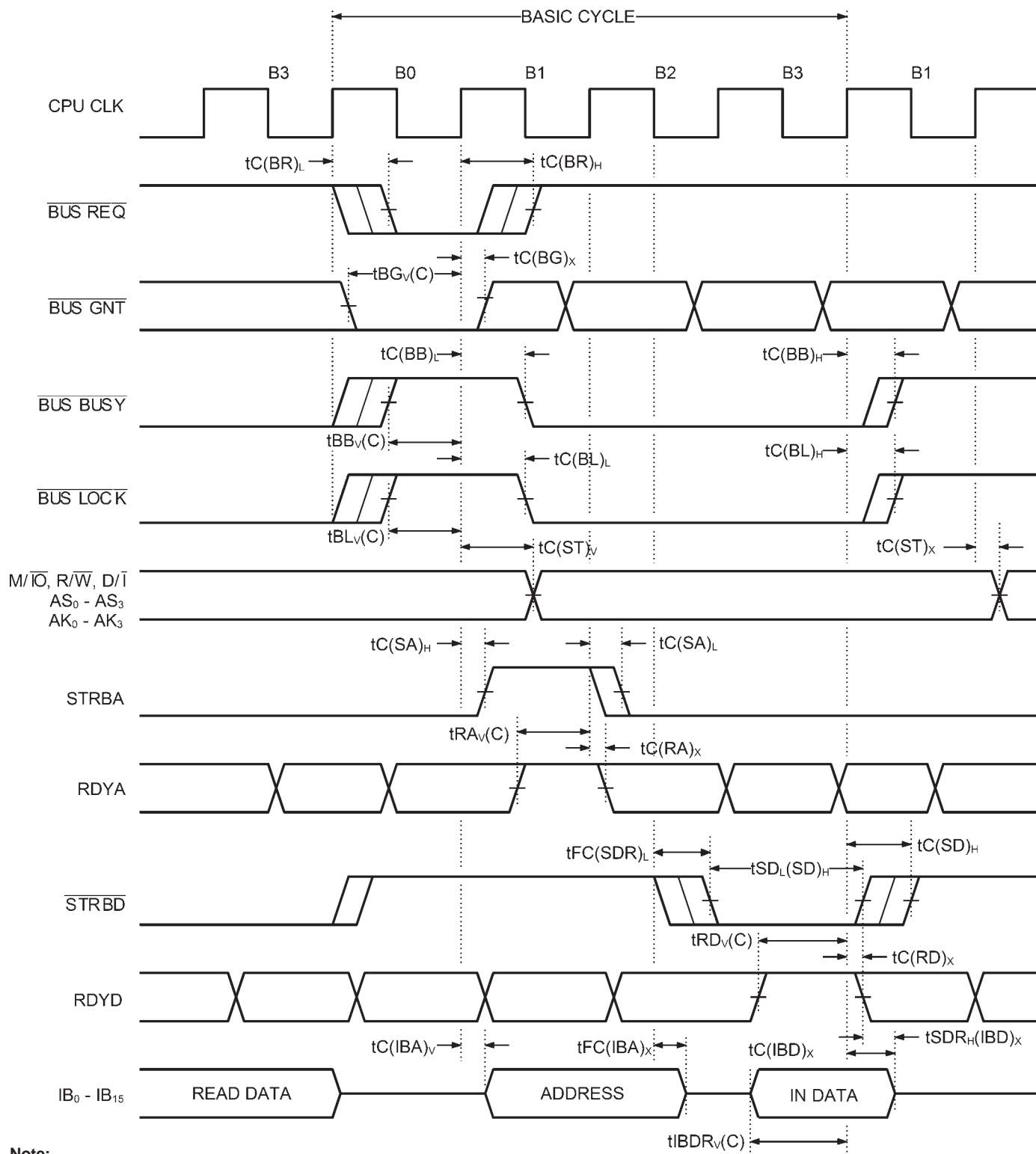

Note:
All time measurements on active signals relate to the 1.5 volt level.

MINIMUM WRITE BUS CYCLE, FOLLOWED BY A NON-BUS CYCLE, TIMING DIAGRAM

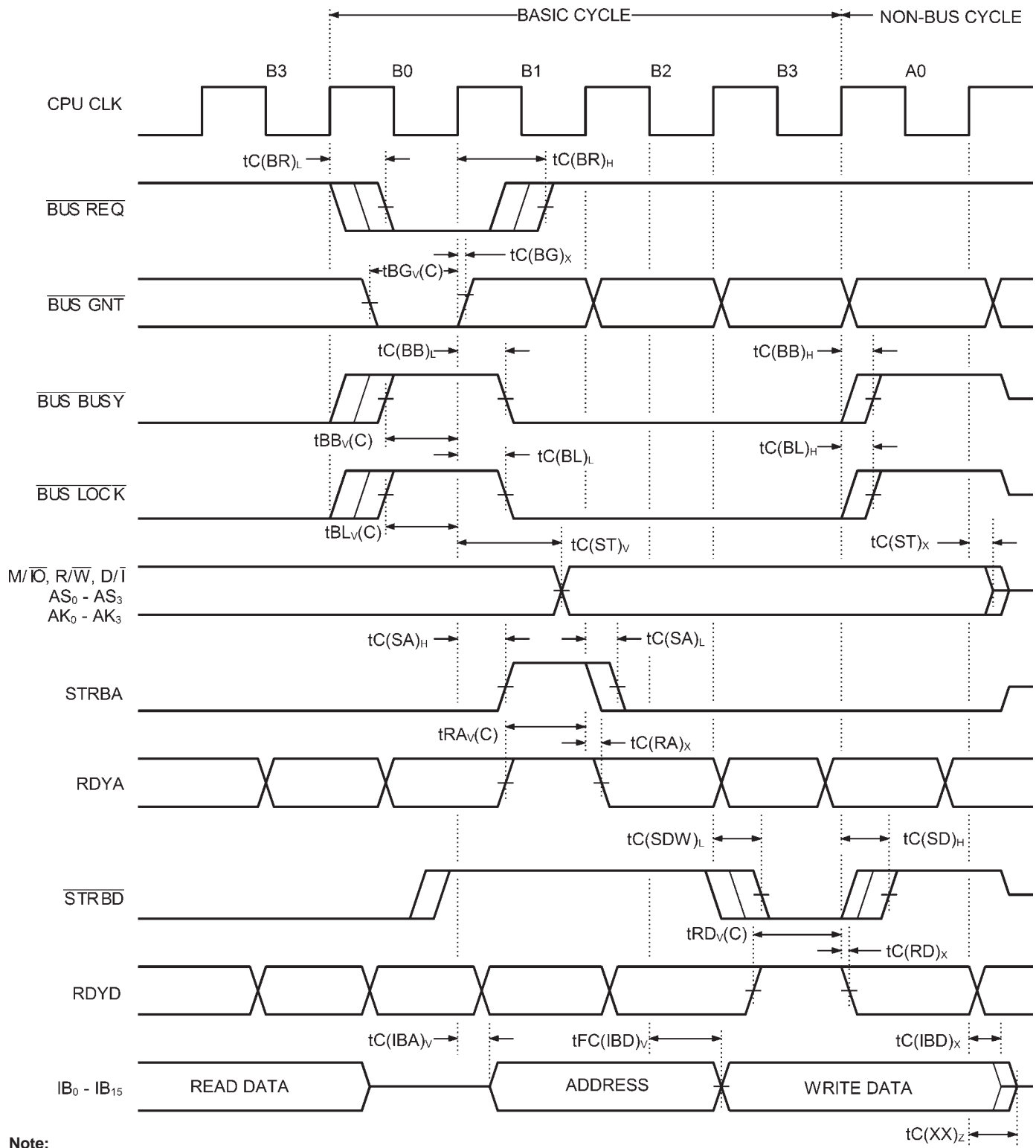

Note:
All time measurements on active signals relate to the 1.5 volt level.

TRIGO RST DISCRETE TIMING DIAGRAM

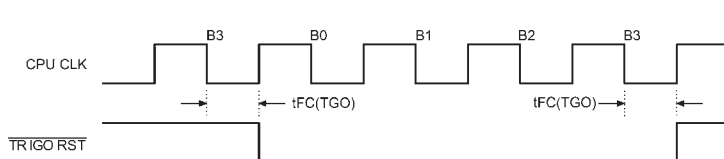

DMA EN DISCRETE TIMING DIAGRAM

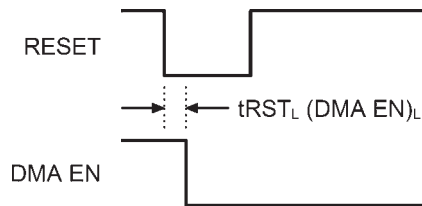

NORMAL POWER UP DISCRETE TIMING DIAGRAM

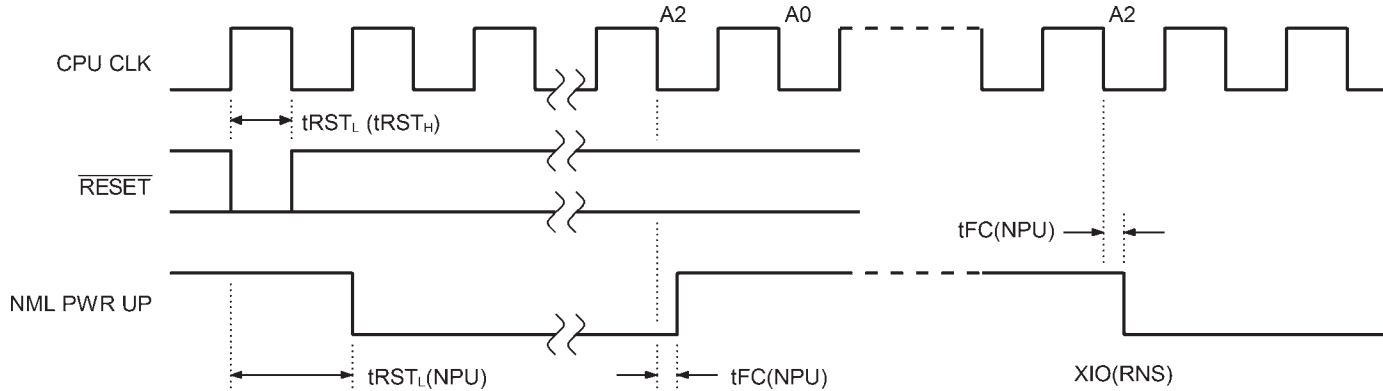

XIO OPERATIONS

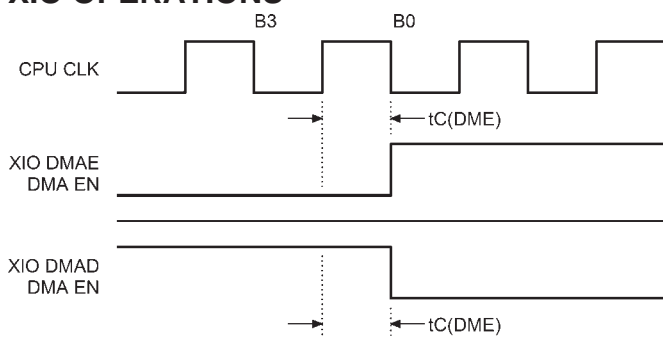

SNEW DISCRETE TIMING DIAGRAM

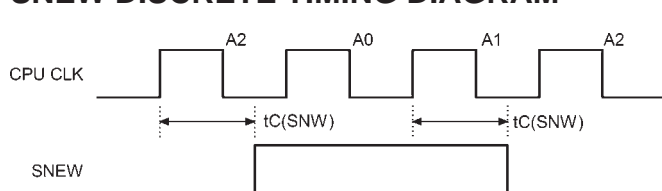

Note:

All time measurements on active signals relate to the 1.5 volt level.

EXTERNAL FAULTS AND INTERRUPTS TIMING DIAGRAM

Edge-sensitive interrupts and faults (SYSFLT₀, SYSFLT₁) min. pulse width

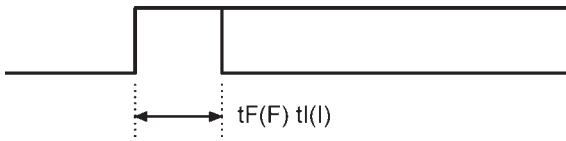

Level-sensitive interrupts

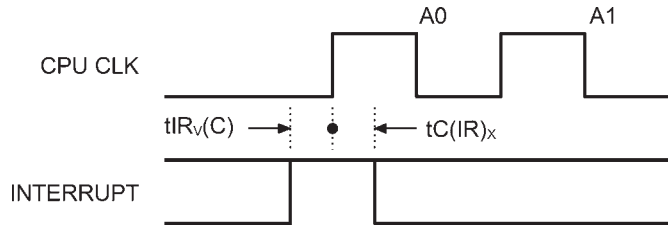

Note:
 $tC(IR)_x$ max = 35 clocks

Level-sensitive faults

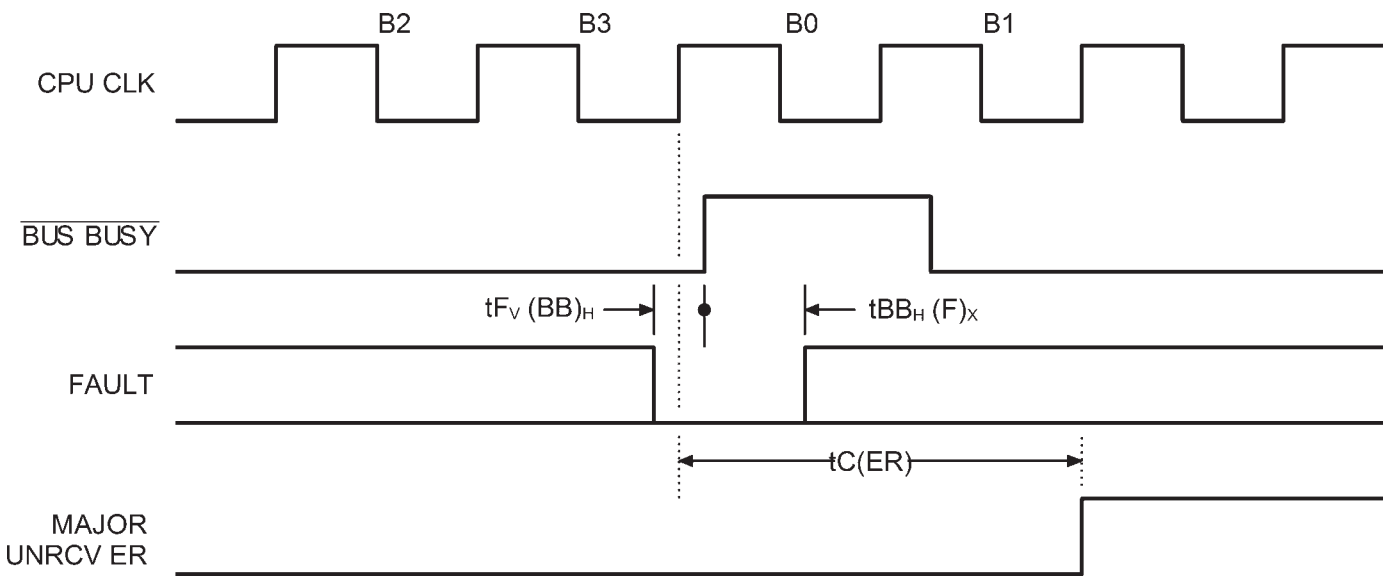

Note:
 All time measurements on active signals relate to the 1.5 volt level.

CON REQ

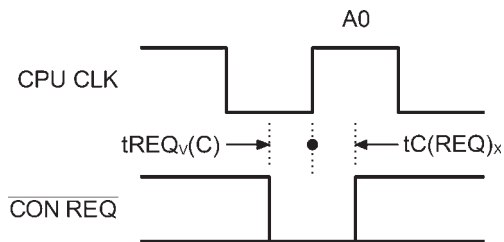

BUS ACQUISITION

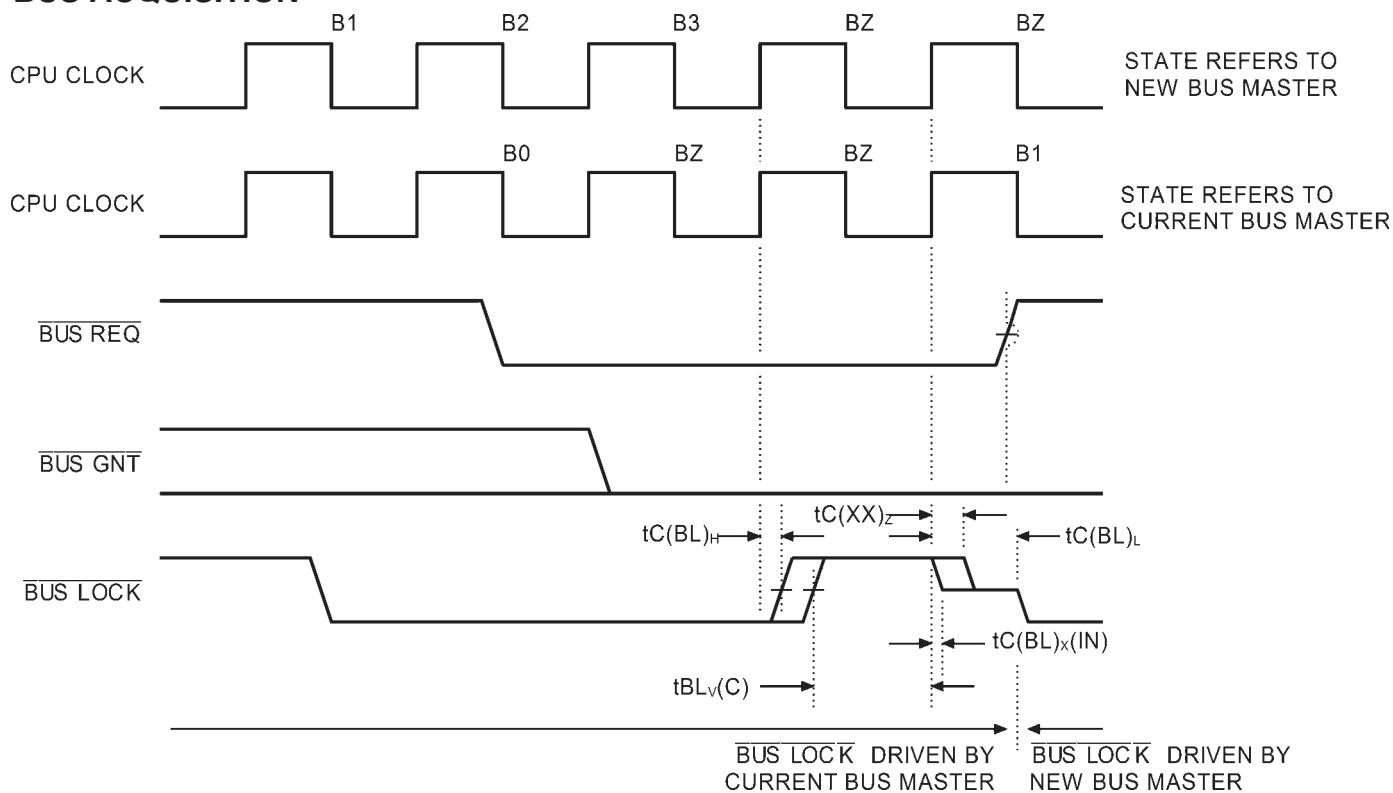

Note:

A CPU contending for the BUS, will assert the $\overline{BUS REQ}$ line, and will acquire it when $\overline{BUS GNT}$ is asserted and the BUS is not locked ($\overline{BUS LOCK}$ is high).

SWITCHING TIME TEST CIRCUITS

Standard Output (Non-Three-State)

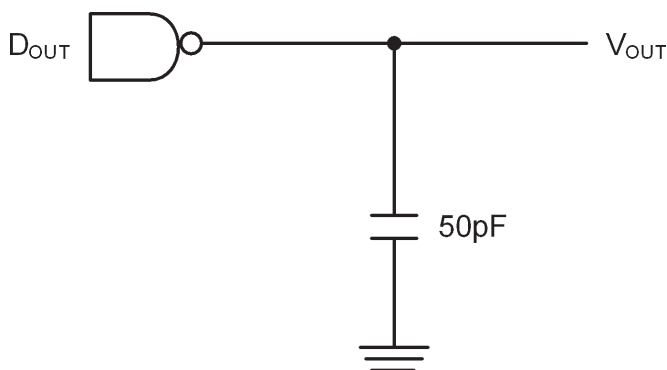

Three-State

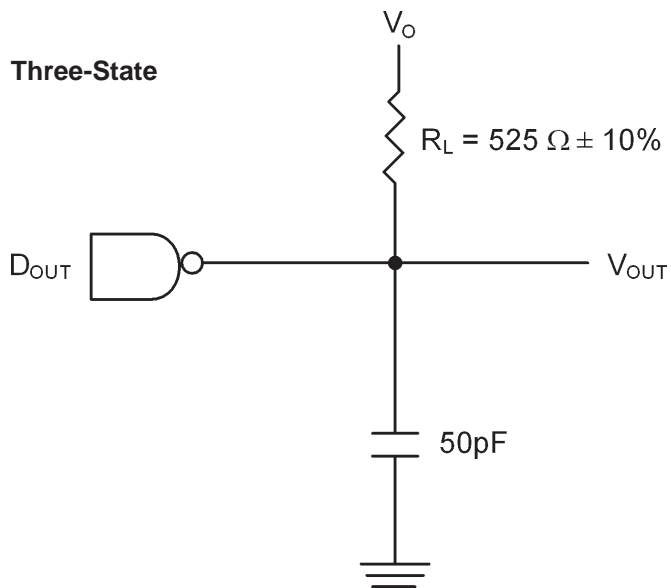

Note:

All time measurements on active signals relate to the 1.5 volt level.

Parameter	V0	VMEA
t_{PLZ}	$\geq 3V$	0.5V
t_{PHZ}	0V	$V_{CC} - 0.5V$
t_{PXL}	$V_{CC}/2$	1.5V
t_{PXH}	$V_{CC}/2$	1.5V

P1750 AE/SOS Terminal Connections Case Types - QL and QG

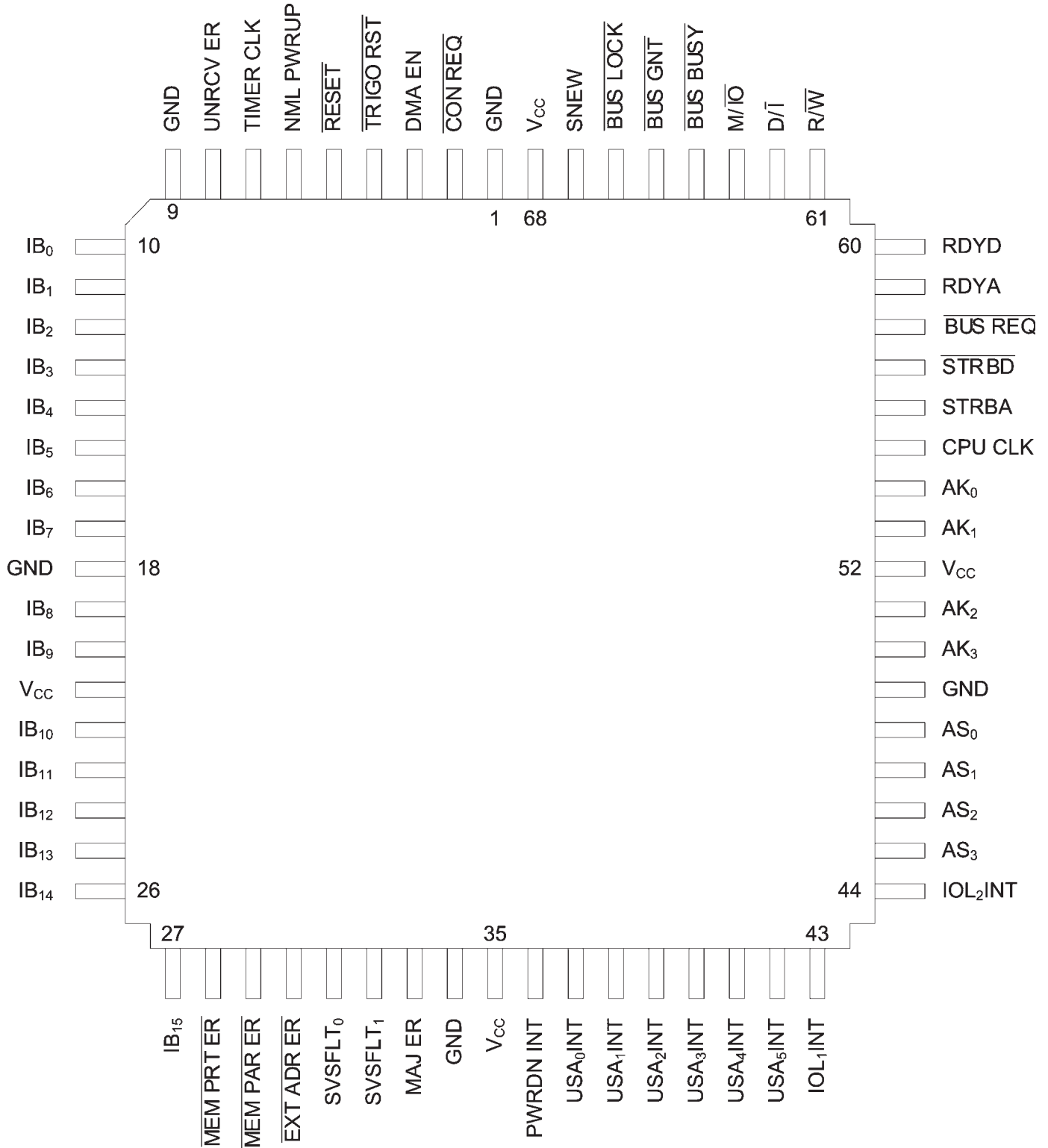

SIGNAL DESCRIPTIONS

CLOCKS AND EXTERNAL REQUESTS

Mnemonic	Name	Description
CPU CLK	CPU clock	A single phase input clock signal (0-30 MHz, 40 percent to 60 percent duty cycle).
TIMER CLK	Timer clock	A 100 kHz input that, after synchronization with CPU CLK provides the clock for timer A and timer B. If timers are used, the CPU CLK signal frequency must be > 300 kHz.
$\overline{\text{RESET}}$	Reset	An active LOW input that initializes the device.
$\overline{\text{CONREQ}}$	Console request	An active LOW input that initiates console operations after completion of the current instruction.

INTERRUPT INPUTS

Mnemonic	Name	Description
PWRDNINT	Power down interrupt	An interrupt request input that cannot be masked or disabled. This signal is active on the positive going edge or the high level, according to the interrupt mode bit in the configuration register.
USR ₀ INT - USR ₅ INT	User interrupt	Interrupt request input signals that are active on the positive going edge or the high level, according to the interrupt mode bit in the configuration register.
IOL ₁ INT IOL ₂ INT	I/O level interrupts	Active HIGH interrupt request inputs that can be used to expand the number of user interrupts.

FAULTS

Mnemonic	Name	Description
$\overline{\text{MEM PRT ER}}$	Memory protect error	An active LOW input generated by the MMU or BPU, or both and sampled by the $\overline{\text{BUS BUSY}}$ signal into the Fault Register (bit 0 CPU bus cycle, bit 1 if non-CPU bus cycle).
$\overline{\text{MEM PAR ER}}$	Memory parity error	An active LOW input sampled by the $\overline{\text{BUS BUSY}}$ signal into bit 2 of the fault register.
$\overline{\text{EXTADR ER}}$	External address error	An active LOW input sampled by the $\overline{\text{BUS BUSY}}$ signal into the Fault register (bit 5 or 8), depending on the cycle (memory or I/O).
SYSFLT ₀ SYSFLT ₁	System fault ₀ , System fault ₁ ,	Asynchronous, positive edge-sensitive inputs that set bit 7 (SYSFLT ₀) or bits 13 and 15 (SYSFLT ₁) in the Fault register.

ERROR CONTROL

Mnemonic	Name	Description
UNRCVER	Unrecoverable error	An active HIGH output that indicates the occurrence of an error classified as unrecoverable.
MAJ ER	Major error	An active HIGH output that indicates the occurrence of an error classified as major.

SIGNAL DESCRIPTIONS (Continued)

BUS CONTROL

Mnemonic	Name	Description
D/\bar{I}	Data or instruction	An output signal that indicates whether the current bus cycle access is for Data (HIGH) or Instruction (LOW). It is three-state during bus cycles not assigned to this CPU. This line can be used as an additional memory address bit for systems that require separate data and program memory.
R/\bar{W}	Read or write	An output signal that indicates direction of data flow with respect to the current bus master. A HIGH indicates a read or input operation and a LOW indicates a write or output operation. The signal is three-state during bus cycles not assigned to this CPU.
$M/\bar{I/O}$	Memory or I/O	An output signal that indicates whether the current bus cycle is memory (HIGH) or I/O (LOW). This signal is three-state during bus cycles not assigned to this CPU.
STRBA	Address strobe	An active HIGH output that can be used to externally latch the memory or I/O address at the high-to-low transition of the strobe. The signal is three-state during bus cycles not assigned to this CPU.
RDYA	Address ready	An active HIGH input that can be used to extend the address phase of a bus cycle. When RDYA is not active wait states are inserted by the device to accommodate slower memory or I/O devices.
$\overline{\text{STRBD}}$	Data strobe	An active LOW output that can be used to strobe data in memory and XIO cycles. This signal is three-state during bus cycles not assigned to this CPU.
RDYD	Data ready	An active HIGH input that extends the data phase of a bus cycle. When RDYD is not active, wait states are inserted by the device to accommodate slower memory or I/O devices.

INFORMATION BUS

Mnemonic	Name	Description
$IB_0 - IB_{15}$	Information bus	A bidirectional time-multiplexed address/data bus that is three-state during bus cycles not assigned to this CPU. IB_0 is the most significant bit.

STATUS BUS

Mnemonic	Name	Description
$AK_0 - AK_3$	Access key	Outputs used to match the access lock in the MMU for memory accesses (a mismatch will cause the MMU to pull the MEM PRT ER signal LOW), and also indicates processor state (PS). Privileged instructions can be executed with PS = 0 only. These signals are three-state during bus cycles not assigned to this CPU.
$AS_0 - AS_3$	Address state	Outputs that select the page register group in the MMU. It is three-state during bus cycles not assigned to this CPU. [These outputs together with D/\bar{I} can be used to expand the device direct addressing space to 4 MBytes, in a nonprotected mode (no MMU)]. However, using this addressing mode may produce situations not specified in MIL-STD-1750A.

SIGNAL DESCRIPTIONS (Continued)**BUS ARBITRATION**

Mnemonic	Name	Description
$\overline{\text{BUS REQ}}$	Bus request	An active LOW output that indicates the CPU requires the bus. It becomes inactive when the CPU has acquired the bus and started the bus cycle.
$\overline{\text{BUS GNT}}$	Bus grant	An active LOW input from an external arbiter that indicates the CPU currently has the highest priority bus request. If the bus is not used and not locked, the CPU may begin a bus cycle, commencing with the next CPU clock. A HIGH level will hold the CPU in Hi-Z state (Bz), three-stating the IB bus status lines ($\overline{\text{D/I}}$, $\overline{\text{R/W}}$, $\overline{\text{M/I/O}}$), strobes ($\overline{\text{STRBA}}$, $\overline{\text{STRBD}}$), and all the other lines that go three-state when this CPU does not have the bus.
$\overline{\text{BUS BUSY}}$	Bus busy	An active LOW, bidirectional signal used to establish the beginning and end of a bus cycle. The trailing edge (low-to-high transition) is used for sampling bits into the fault register. It is three-state in bus cycles not assigned to this CPU. However, the CPU monitors the $\overline{\text{BUS BUSY}}$ line for latching non-CPU bus cycle faults into the fault register.
$\overline{\text{BUS LOCK}}$	Bus lock	An active LOW, bi-directional signal used to lock the bus for successive bus cycles. During non-locked bus cycles, the $\overline{\text{BUS LOCK}}$ signal mimics the $\overline{\text{BUS BUSY}}$ signal. It is three-state during bus cycles not assigned to this CPU. The following instructions will lock the bus: INCM, DECM, SB, RB, TSB, SRM, STUB and STLB.

DISCRETE CONTROL

Mnemonic	Name	Description
DMA EN	Direct memory Access enable	An active HIGH output that indicates the DMA is enabled. It is disabled when the CPU is initialized (reset) and can be enabled or disabled under program control (I/O commands DMAE, DMAD).
NML PWRUP	Normal power up	An active HIGH output that is set when the CPU has successfully completed the built-in self test in the initialization sequence. It can be reset by the I/O command RNS.
SNEW	Start new	An active HIGH output that indicates a new instruction is about to start executing in the next cycle.
$\overline{\text{TRIGORST}}$	Trigger-go reset	An active LOW discrete output. This signal can be pulsed low under program control I/O address 400B (Hex) and is automatically pulsed during processor initialization.

ORDERING INFORMATION

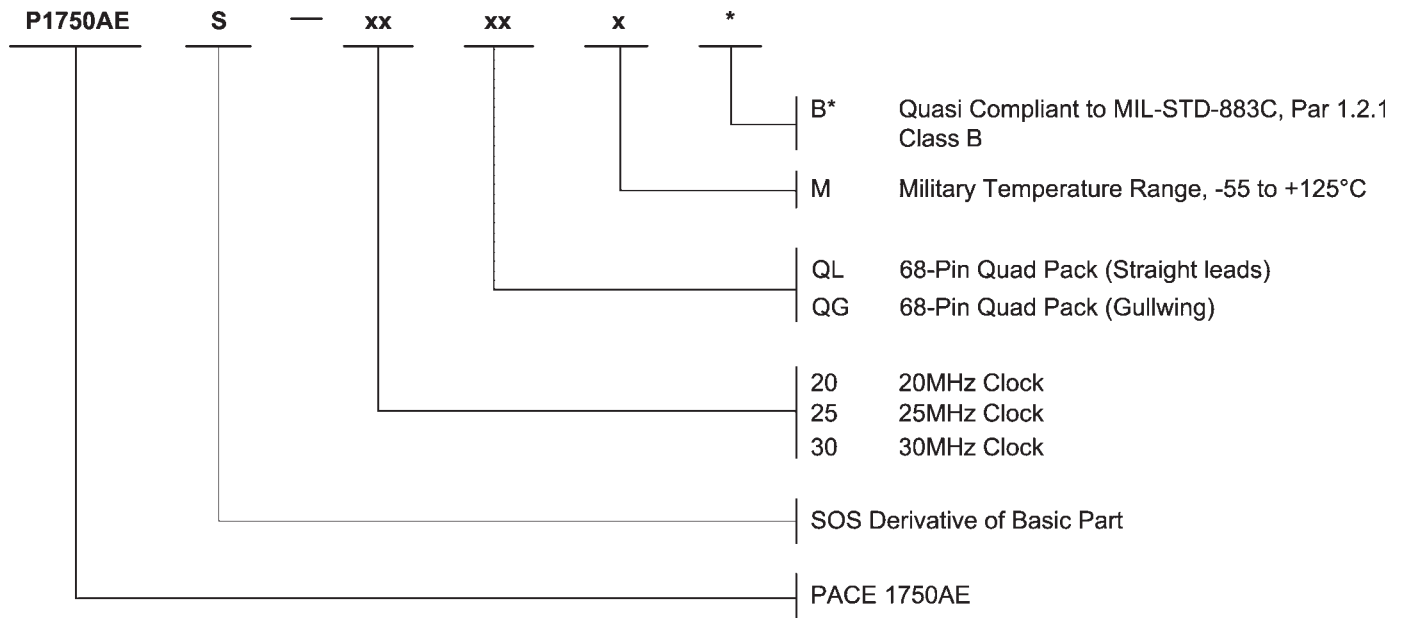

CASE OUTLINE 1:

68 Lead Quad Pack with Straight Leads (Ordering Code QL)

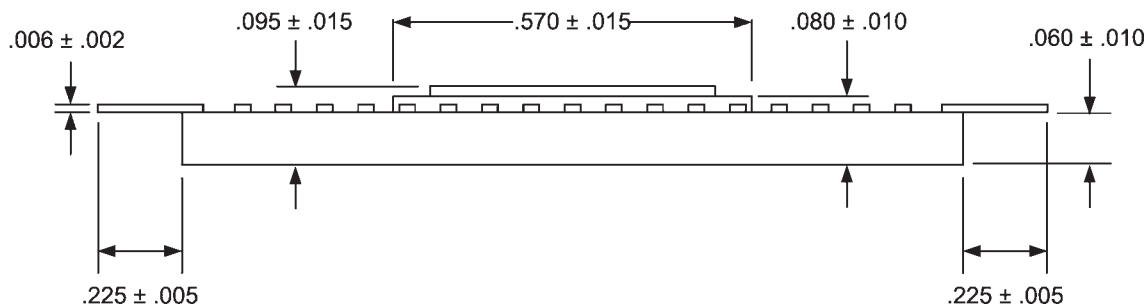
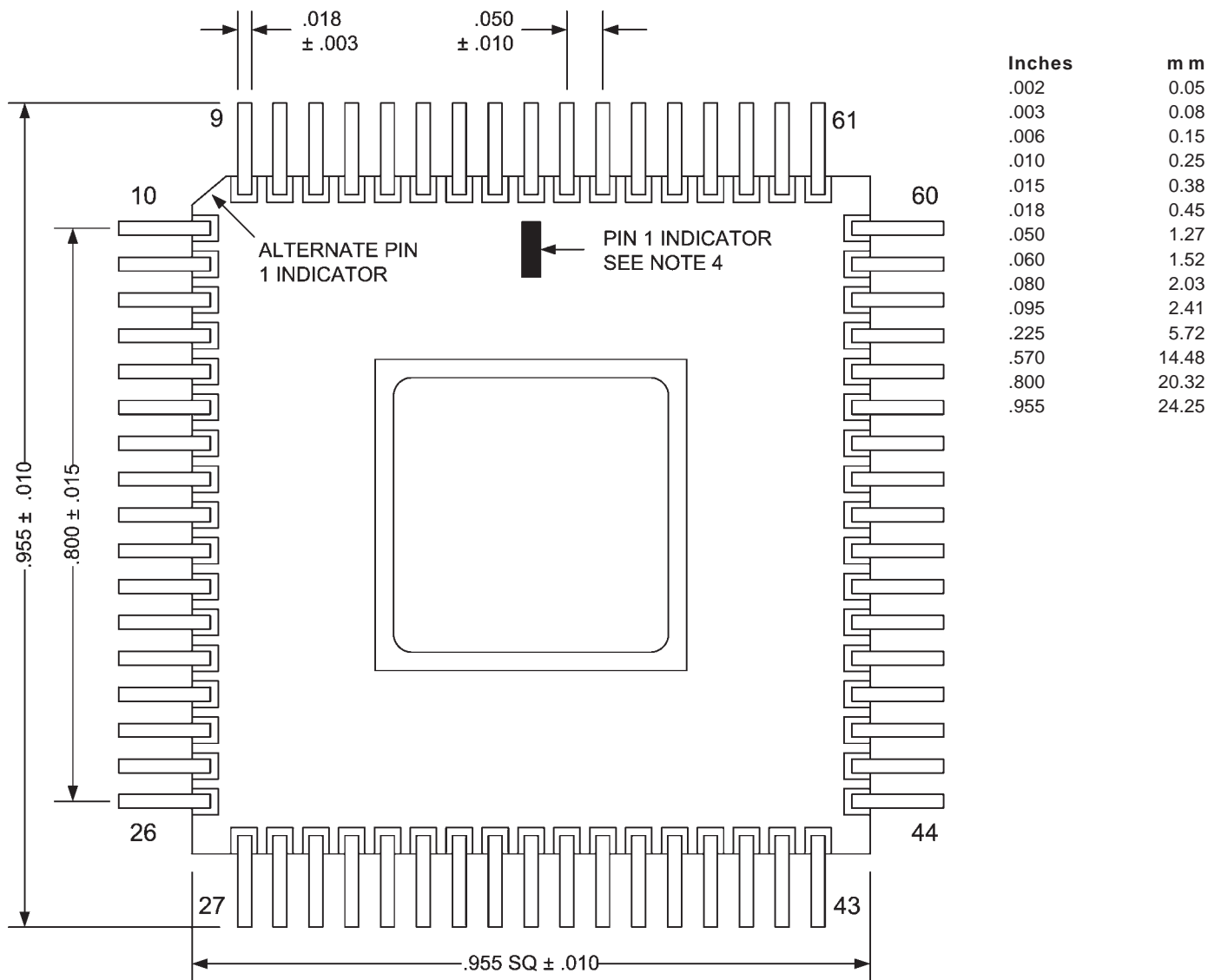

NOTES:

- 1) Dimensions are in inches.
- 2) Metric equivalents are given for general information only.
- 3) Unless otherwise specified, tolerances are .02 (0.5 mm) for two place decimals and .005 (0.13 mm) for three place decimals.
- 4) Pin 1 indicator can be either rectangle, dot, or triangle at specified location or referenced to the uniquely beveled corner.
- 5) Corners indicated as notched may be either notched or square.

CASE OUTLINE 2:

68 Lead Quad Pack with Gullwing Leads (Ordering Code QG)

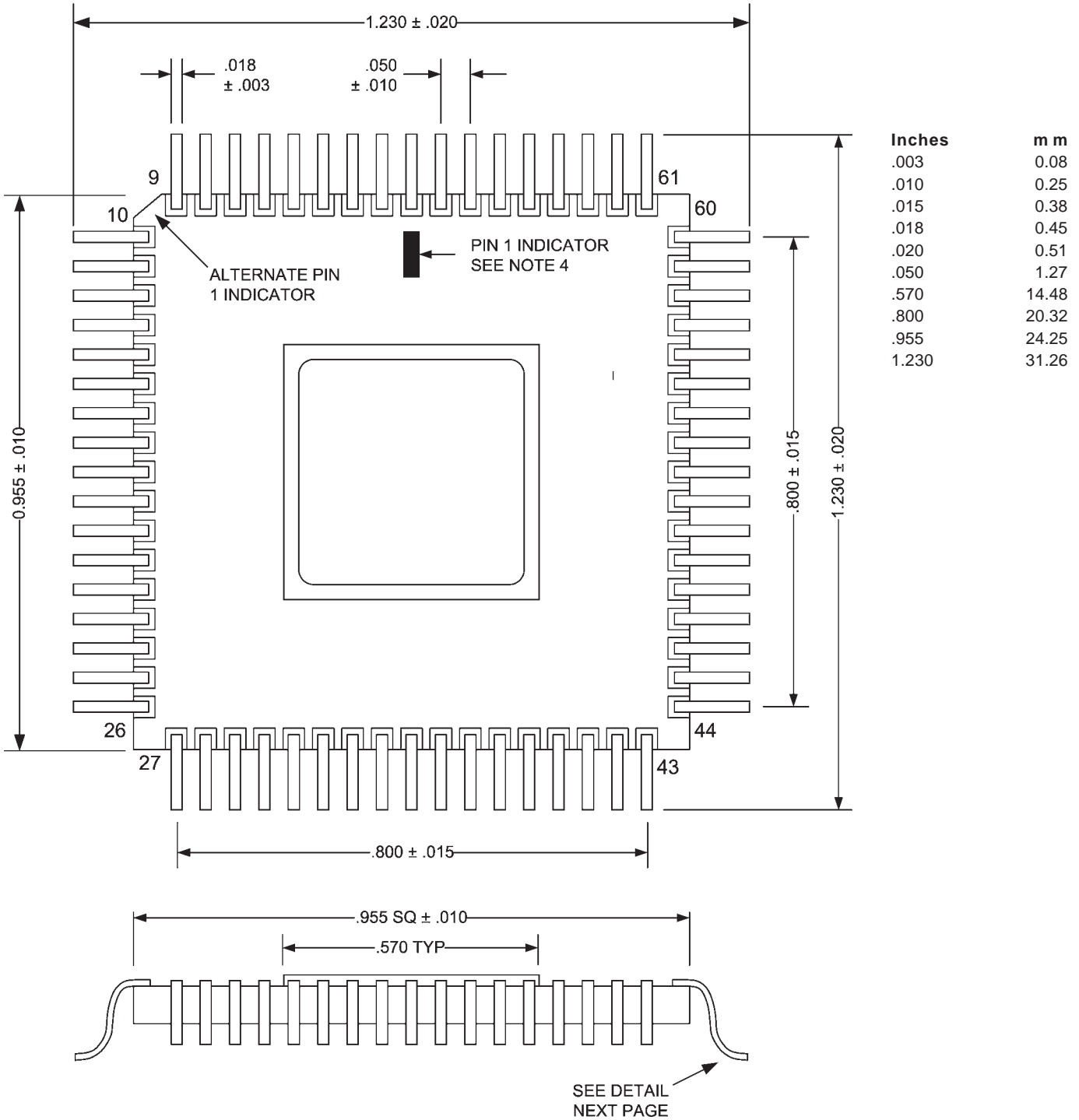

NOTES:

- 1) Dimensions are in inches.
- 2) Metric equivalents are given for general information only.
- 3) Unless otherwise specified, tolerances are .02 (0.5 mm) for two place decimals and .005 (0.13 mm) for three place decimals.
- 4) Pin 1 indicator can either be rectangle, dot, or triangle at specified location or referenced to the uniquely beveled corner.
- 5) Corners indicated as notched may be either notched or square (with radius).
- 6) Case 2 is derived from Case 1 by forming the leads to the shown gullwing configuration.

LEAD FORM DETAIL

Symbol	INCHES	
	Min	Max
A	0.048	0.090
A1	0.011	0.031
B	0.016	0.021
C	0.004	0.008
e1	0.050 BSC	
D	1.210	1.250
D1	0.945	0.965
D2	0.800 BSC	
E	1.210	1.250
E1	0.945	0.965
E2	0.800 BSC	
L*	0.270 Nominal	
L0	0.120	0.210
L3	0.040	0.050
L4	0.086	0.109
R1	0.018	0.020
R2	0.018	0.020
Φ_1	4°	8°
Φ_2	-1°	7°
A0**		0.141

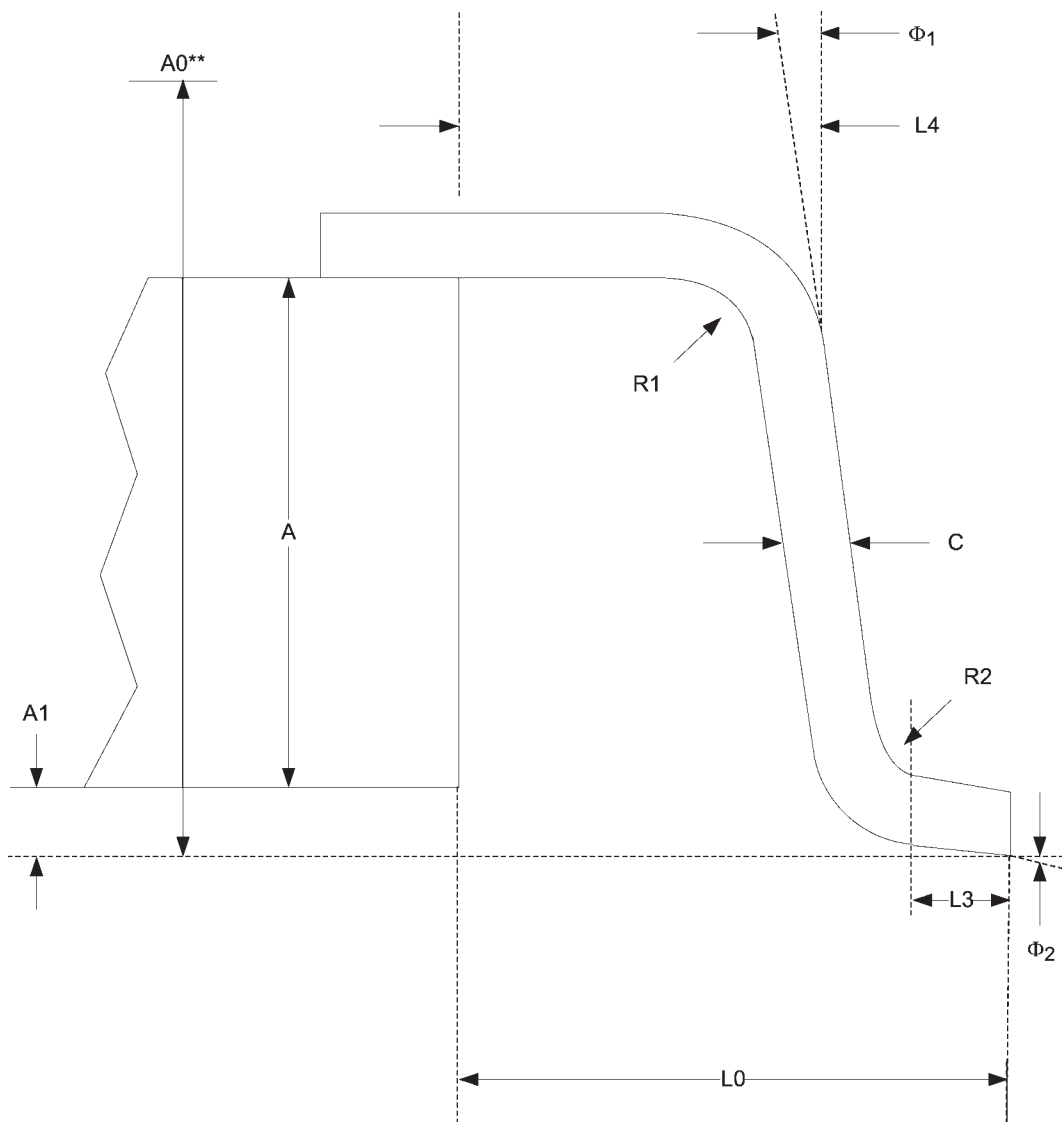

* Lead length in the straight lead configuration, prior to leadforming (used for all test and in-process WIP operations).

** Measured from the highest of the top of the leads or the top of the lid.

REVISIONS

DOCUMENT NUMBER:		MICRO-7	
DOCUMENT TITLE:		PAGE1750AE SOS 16-BIT PROCESSOR	
REV.	ISSUE DATE	ORIG. OF CHANGE	DESCRIPTION OF CHANGE
ORIG	May-89	RKK	New Data Sheet
A	Jul-04	JDB	Added Pyramid logo
B	Aug-05	JDB	Re-created electronic version