

# P4C1298/P4C1298L ULTRA HIGH SPEED 64K x 4 STATIC CMOS RAM

## FEATURES

- Full CMOS, 6T Cell
- High Speed (Equal Access and Cycle Times)
  - 15/20/25/35 ns (Commercial/Industrial)
  - 15/20/25/35/45 ns (Military)
- Low Power
- Single 5V±10% Power Supply
- Output Enable & Chip Enable control functions
- Data Retention with 2.0V Supply
- Three-State Outputs
- TTL/CMOS Compatible Outputs
- Fully TTL Compatible Inputs
- Standard Pinout (JEDEC Approved)
  - 28-Pin 300 mil DIP, SOJ
  - 28-Pin 350x550 mil LCC

## DESCRIPTION

The P4C1298/L are a 262,144-bit ultra high speed static RAM organized as 64K x 4. The CMOS memory requires no clock or refreshing and has equal access and cycle times. Inputs and outputs are fully TTL-compatible. The RAM operates from a single 5V±10% tolerance power supply. With battery backup, data integrity is maintained for supply voltages down to 2.0V. Current drain is typically 10 µA from a 2.0V supply.

Access times as fast as 15 nanoseconds are available, permitting greatly enhanced system speeds. CMOS is utilized to reduce power consumption.

The P4C1298 is available in a 28-pin 300 mil DIP or SOJ, as well as a 28-pin 350x500 mil LCC package, providing excellent board level densities.

## FUNCTIONAL BLOCK DIAGRAM

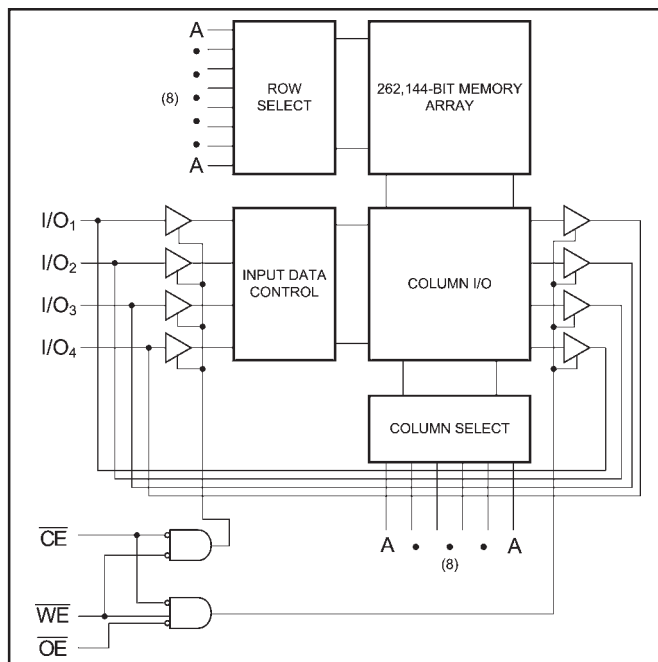

## PIN CONFIGURATION

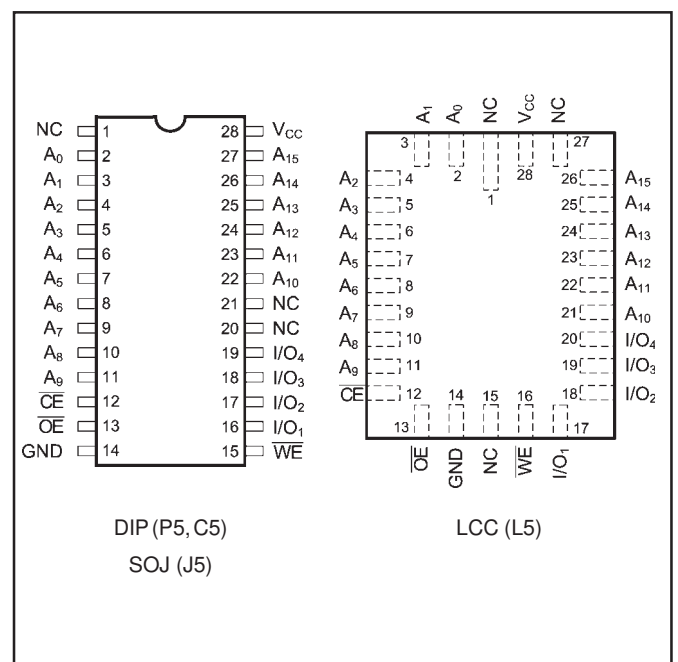

### MAXIMUM RATINGS<sup>(1)</sup>

Symbol	Parameter	Value	Unit
V <sub>CC</sub>	Power Supply Pin with Respect to GND	-0.5 to +7	V
V <sub>TERM</sub>	Terminal Voltage with Respect to GND (up to 7.0V)	-0.5 to V <sub>CC</sub> +0.5	V
T <sub>A</sub>	Operating Temperature	-55 to +125	°C

Symbol	Parameter	Value	Unit
T <sub>BIAS</sub>	Temperature Under Bias	-55 to +125	°C
T <sub>STG</sub>	Storage Temperature	-65 to +150	°C
P <sub>T</sub>	Power Dissipation	1.0	W
I <sub>OUT</sub>	DC Output Current	50	mA

### RECOMMENDED OPERATING TEMPERATURE AND SUPPLY VOLTAGE

Grade(2)	Ambient Temperature	GND	V <sub>CC</sub>
Military	-55°C to +125°C	0V	5.0V ± 10%
Industrial	-40°C to +85°C	0V	5.0V ± 10%
Commercial	0°C to +70°C	0V	5.0V ± 10%

### CAPACITANCES<sup>(4)</sup>

V<sub>CC</sub> = 5.0V, T<sub>A</sub> = 25°C, f = 1.0MHz

Symbol	Parameter	Conditions	Typ.	Unit
C <sub>IN</sub>	Input Capacitance	V <sub>IN</sub> = 0V	5	pF
C <sub>OUT</sub>	Output Capacitance	V <sub>OUT</sub> = 0V	7	pF

### DC ELECTRICAL CHARACTERISTICS

Over recommended operating temperature and supply voltage<sup>(2)</sup>

Symbol	Parameter	Test Conditions	P4C1298		P4C1298L		Unit	
			Min	Max	Min	Max		
V <sub>IH</sub>	Input High Voltage		2.2	V <sub>CC</sub> +0.5	2.2	V <sub>CC</sub> +0.5	V	
V <sub>IL</sub>	Input Low Voltage		-0.5 <sup>(3)</sup>	0.8	-0.5 <sup>(3)</sup>	0.8	V	
V <sub>HC</sub>	CMOS Input High Voltage		V <sub>CC</sub> -0.2	V <sub>CC</sub> +0.5	V <sub>CC</sub> -0.2	V <sub>CC</sub> +0.5	V	
V <sub>LC</sub>	CMOS Input Low Voltage		-0.5 <sup>(3)</sup>	0.2	-0.5 <sup>(3)</sup>	0.2	V	
V <sub>CD</sub>	Input Clamp Diode Voltage	V <sub>CC</sub> = Min., I <sub>IN</sub> = 18 mA		-1.2		-1.2	V	
V <sub>OL</sub>	Output Low Voltage (TTL Load)	I <sub>OL</sub> = +8 mA, V <sub>CC</sub> = Min.		0.4		0.4	V	
V <sub>OH</sub>	Output High Voltage (TTL Load)	I <sub>OH</sub> = -4 mA, V <sub>CC</sub> = Min.	2.4		2.4		V	
I <sub>LI</sub>	Input Leakage Current	V <sub>CC</sub> = Max. V <sub>IN</sub> = GND to V <sub>CC</sub>	-5	+5	-10	+10	µA	
I <sub>LO</sub>	Output Leakage Current	V <sub>CC</sub> = Max., CE = V <sub>IH</sub> V <sub>OUT</sub> = GND to V <sub>CC</sub>	-5	+5	-10	+10	µA	
I <sub>SB</sub>	Standby Power Supply Current (TTL Input Levels)	CE ≥ V <sub>IH</sub> V <sub>CC</sub> = Max., f = Max., Outputs Open	Mil	—	40	—	20	mA
			Ind/Comm	—	20	—	N/A	mA
I <sub>SB1</sub>	Standby Power Supply Current (CMOS Input Levels)	CE ≥ V <sub>HC</sub> V <sub>CC</sub> = Max., f = 0, Outputs Open V <sub>IN</sub> ≤ V <sub>LC</sub> or V <sub>IN</sub> ≥ V <sub>HC</sub>	Mil	—	10	—	10	mA
			Ind/Comm	—	10	—	N/A	mA

**Notes:**

1. Stresses greater than those listed under MAXIMUM RATINGS may cause permanent damage to the device. This is a stress rating only and functional operation of the device at these or any other conditions above those indicated in the operational sections of this specification is not implied. Exposure to MAXIMUM rating conditions for extended periods may affect reliability.
2. Extended temperature operation guaranteed with 400 linear feet per minute of air flow.
3. Transient inputs with V<sub>IL</sub> and I<sub>IL</sub> not more negative than -3.0V and -100mA, respectively, are permissible for pulse widths up to 20ns.
4. This parameter is sampled and not 100% tested.

## POWER DISSIPATION CHARACTERISTICS VS. SPEED

Symbol	Parameter	Temperature Range	-15	-20	-25	-35	Unit
$I_{CC}$	Dynamic Operating Current*	Commercial	160	125	115	110	mA
		Industrial	160	135	120	115	mA
		Military	160	150	120	120	mA

\* $V_{CC} = 5.5V$ . Tested with outputs open.  $f = \text{Max}$ . Switching inputs are 0V and 3V.  $CE = V_{IL}$

## DATA RETENTION CHARACTERISTICS (P4C1298L ONLY)

Symbol	Parameter	Test Conditions	Min	Typ.* $V_{CC} =$		Max $V_{CC} =$		Unit
				2.0V	3.0V	2.0V	3.0V	
$V_{DR}$	$V_{CC}$ for Data Retention		2.0					V
$I_{CCDR}$	Data Retention Current	$CE \geq V_{CC} - 0.2V,$ $V_{IN} \geq V_{CC} - 0.2V$ or $V_{IN} \leq 0.2V$		10	15	1000	2000	$\mu A$
$t_{CDR}$	Chip Deselect to Data Retention Time		0					ns
$t_R^\dagger$	Operation Recovery Time		$t_{RC}^\S$					ns

\* $T_A = +25^\circ C$

$^\S t_{RC}$  = Read Cycle Time

$^\dagger$  This parameter is guaranteed but not tested.

## DATA RETENTION WAVEFORM

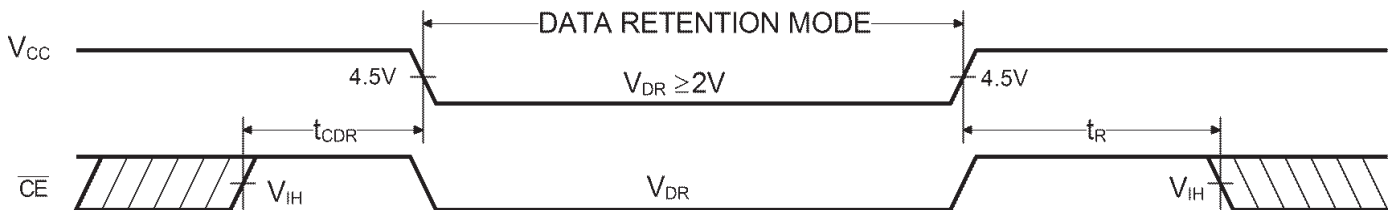

### AC CHARACTERISTICS—READ CYCLE

( $V_{CC} = 5V \pm 10\%$ , All Temperature Ranges)<sup>(2)</sup>

Sym.	Parameter	-15		-20		-25		-35		-45		Unit
		Min	Max	Min	Max	Min	Max	Min	Max	Min	Max	
$t_{RC}$	Read Cycle Time	15		20		25		35		45		ns
$t_{AA}$	Address Access Time		15		20		25		35		45	ns
$t_{AC}$	Chip Enable Access Time		15		20		25		35		45	ns
$t_{OH}$	Output Hold from Address Change	3		3		3		3		3		ns
$t_{LZ}$	Chip Enable to Output in Low Z	3		3		3		3		3		ns
$t_{HZ}$	Chip Disable to Output in High Z		8		10		15		15		20	ns
$t_{OE}$	Output Enable Low to Data Valid		8		10		15		25		30	ns
$t_{OLZ}$	Output Enable Low to Low Z	0		0		0		0		0		ns
$t_{OHZ}$	Output Enable High to High Z		9		9		15		20		20	ns
$t_{PU}$	Chip Enable to Power Up Time	0		0		0		0		0		ns
$t_{PD}$	Chip Disable to Power Down Time		15		20		25		35		45	ns

#### TIMING WAVEFORM OF READ CYCLE NO. 1 (OE CONTROLLED)<sup>(5)</sup>

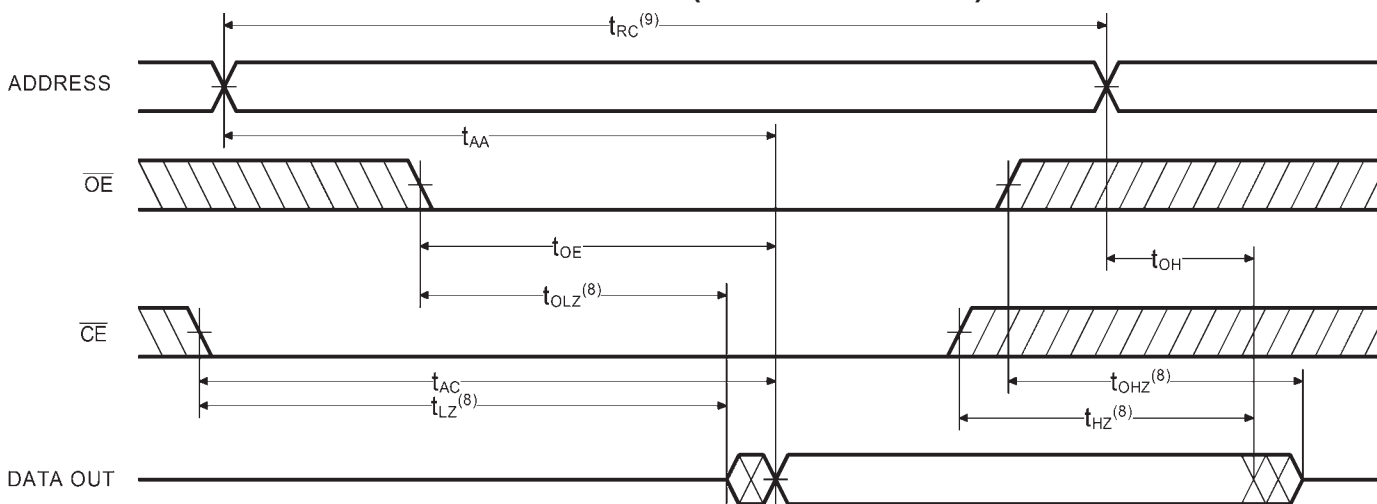

#### TIMING WAVEFORM OF READ CYCLE NO. 2 (ADDRESS CONTROLLED)<sup>(5,6)</sup>

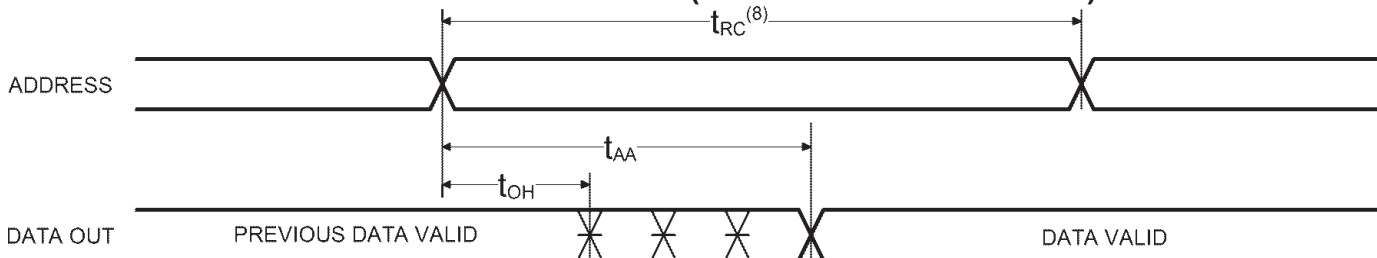

## TIMING WAVEFORM OF READ CYCLE NO. 3 (CE CONTROLLED)<sup>(5,6)</sup>

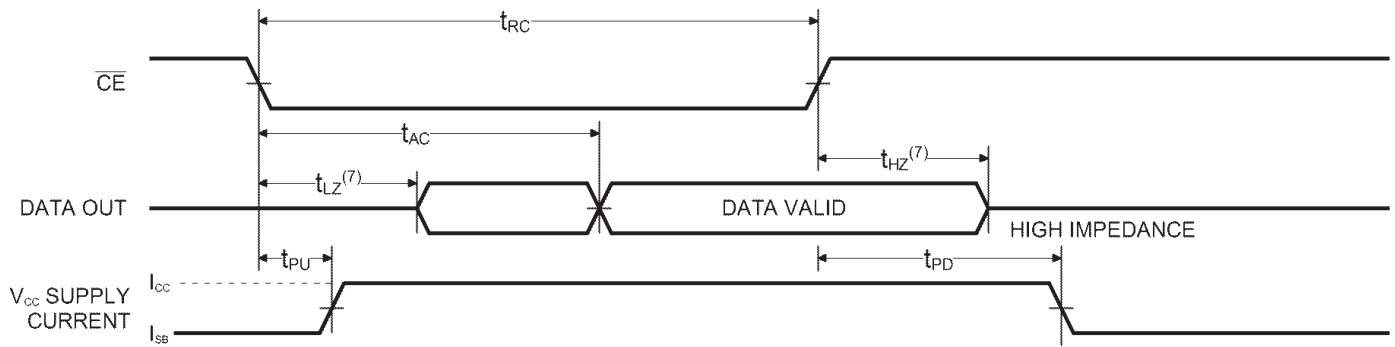

### Notes:

5. CE is LOW and WE is HIGH for READ cycle.

6. WE is HIGH, and address must be valid prior to or coincident with CE transition LOW.

7. Transition is measured  $\pm 200\text{mV}$  from steady state voltage prior to change with specified loading in Figure 1. This parameter is sampled and not 100% tested.

8. Read Cycle Time is measured from the last valid address to the first transitioning address.

## AC CHARACTERISTICS - WRITE CYCLE

( $V_{CC} = 5V \pm 10\%$ , All Temperature Ranges)<sup>(2)</sup>

Sym	Parameter	-15		-20		-25		-35		-45	
		Min	Max	Min	Max	Min	Max	Min	Max	Min	Max
$t_{WC}$	Write Cycle Time	15		20		25		35		45	
$t_{CW}$	Chip Enable Time to End of Write	10		15		20		25		30	
$t_{AW}$	Address Valid to End of Write	10		15		20		25		30	
$t_{AS}$	Address Set-up Time	0		0		0		0		0	
$t_{WP}$	Write Pulse Width	10		15		20		25		30	
$t_{AH}$	Address Hold Time from End of Write	0		0		0		0		0	
$t_{DW}$	Data Valid to End of Write	9		10		15		20		20	
$t_{DH}$	Data Hold Time	0		0		0		0		0	
$t_{WZ}$	Write Enable to Output in High Z		7		10		15		20		20
$t_{OW}$	Output Active from End of Write	0		0		0		0		0	

### TIMING WAVEFORM OF WRITE CYCLE NO. 1 (WE CONTROLLED) <sup>(9)</sup>

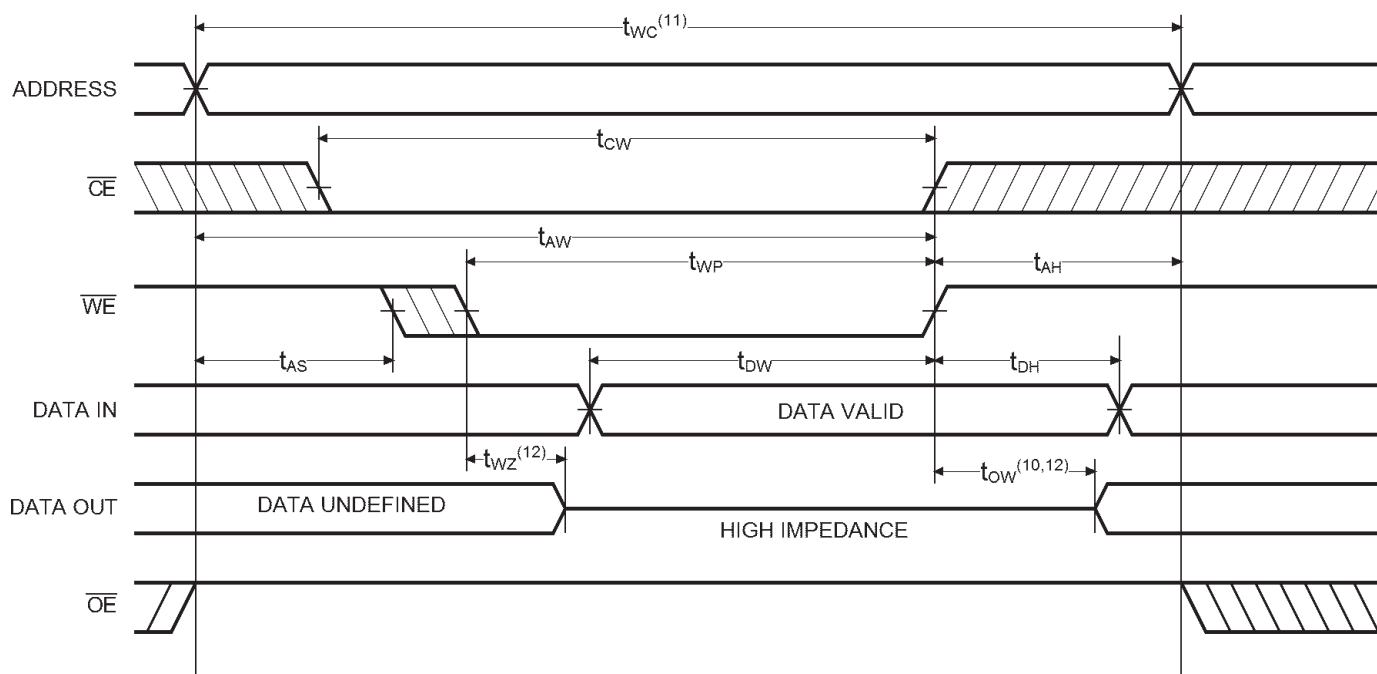

**Notes:**

- 9. CE and WE must be LOW for WRITE cycle.
- 10. OE is LOW for this WRITE cycle.
- 11. If CE goes HIGH simultaneously with WE HIGH, the output remains in a high impedance state.
- 12. Write Cycle Time is measured from the last valid address to the first transition address.
- 13. Transition is measured  $\pm 200mV$  from steady state voltage prior to change with specified loading in Figure 1. This parameter is sampled and not 100% tested.

**TIMING WAVEFORM OF WRITE CYCLE NO. 2 (CE CONTROLLED)<sup>(9,10)</sup>**

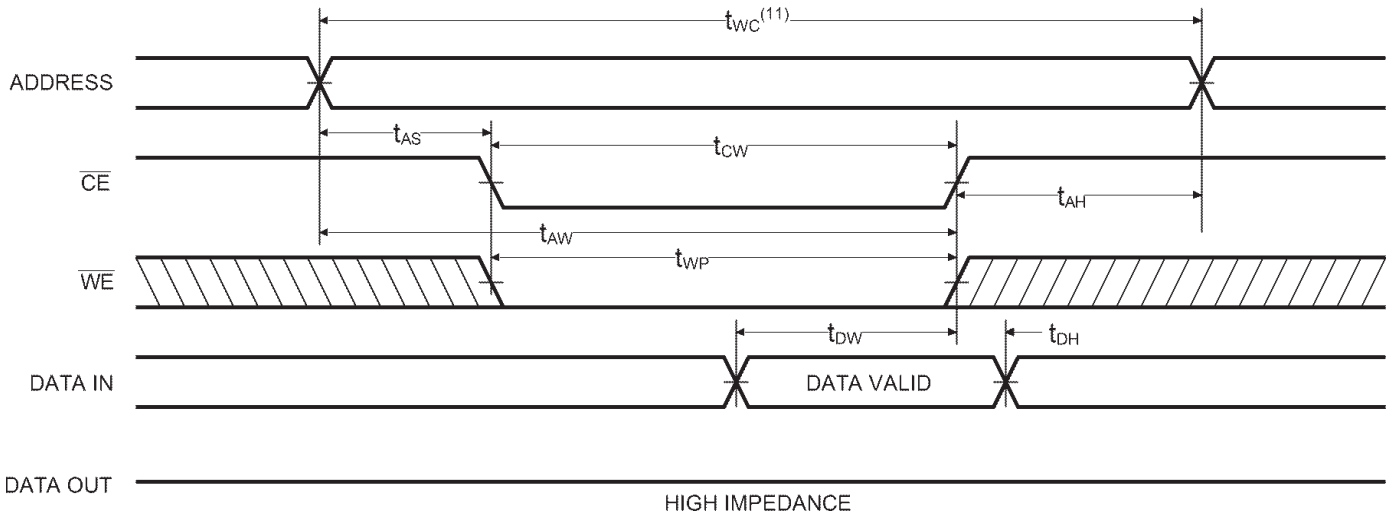

**AC TEST CONDITIONS**

Input Pulse Levels	GND to 3.0V
Input Rise and Fall Times	3ns
Input Timing Reference Level	1.5V
Output Timing Reference Level	1.5V
Output Load	See Figures 1 and 2

**TRUTH TABLE**

Mode	CE	WE	Output	Power
Standby	H	X	High Z	Standby
Read	L	H	D <sub>OUT</sub>	Active
Write	L	L	D <sub>IN</sub>	Active

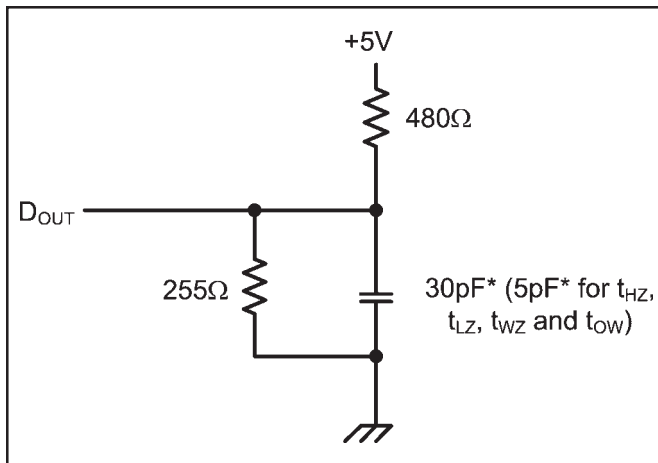

Figure 1. Output Load

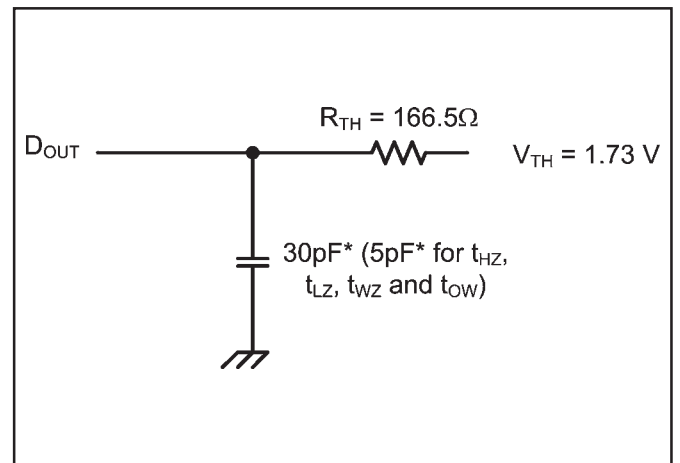

Figure 2. Thevenin Equivalent

\* including scope and test fixture.

**Note:**

Because of the ultra-high speed of the P4C1298, care must be taken when testing this device; an inadequate setup can cause a normal functioning part to be rejected as faulty. Long high-inductance leads that cause supply bounce must be avoided by bringing the V<sub>CC</sub> and ground planes directly up to the contactor fingers. A 0.01 μF high

frequency capacitor is also required between V<sub>CC</sub> and ground. To avoid signal reflections, proper termination must be used; for example, a 50Ω test environment should be terminated into a 50Ω load with 1.73V (Thevenin Voltage) at the comparator input, and a 116Ω resistor must be used in series with D<sub>OUT</sub> to match 166Ω (Thevenin Resistance).

## ORDERING INFORMATION

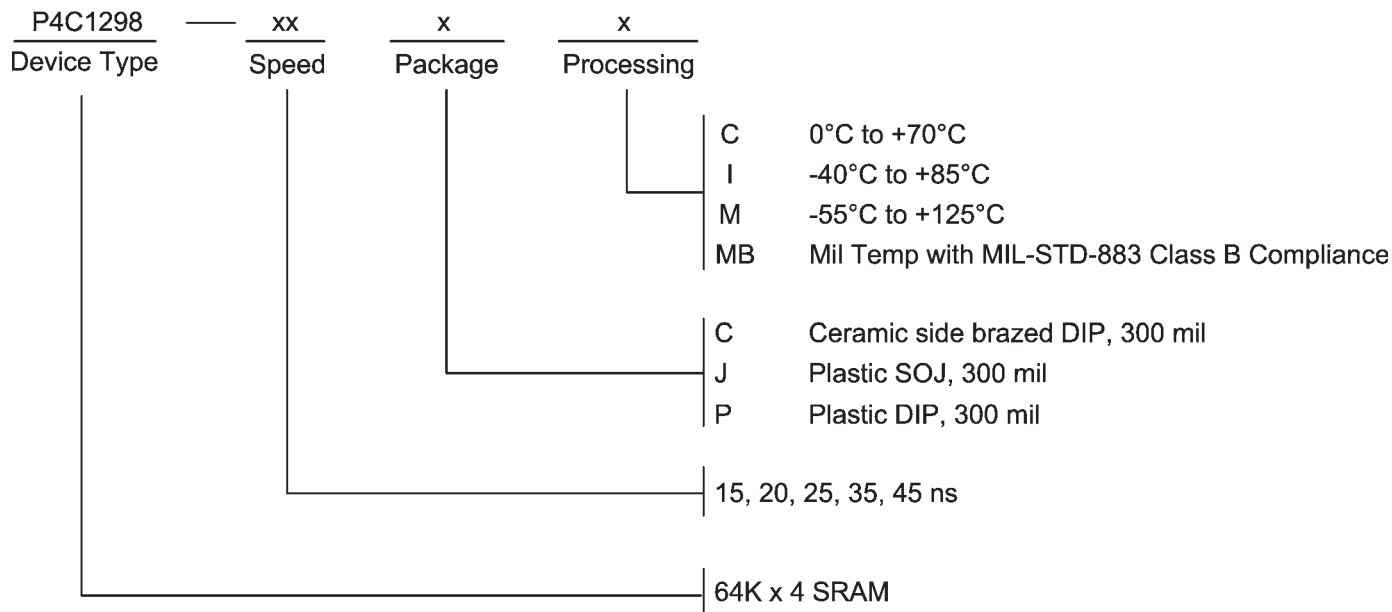

## SELECTION GUIDE

The P4C1298 is available in the following temperature, speed and package options.

Temperature Range	Package	Speed			
		15	20	25	35
Commercial	Plastic SOJ, 300 mil	-15J3C	-20J3C	-25J3C	-35J3C
Industrial	Plastic SOJ, 300 mil	-15J3I	-20J3I	-25J3I	-35J3I
Military Temperature	Ceramic DIP, 300 mil	-15CM	-20CM	-25CM	-35CM
	28-Pin Ceramic LCC	-15L28M	-20L28M	-25L28M	-25L28M
Military Processed*	Ceramic DIP, 300 mil	-15CMB	-20CMB	-25CMB	-35CMB
	28-Pin Ceramic LCC	-15L28MB	-20L28MB	-25L28MB	-25L28MB

Pkg #	<b>J5</b>	
# Pins	28 (300 mil)	
Symbol	<b>Min</b>	<b>Max</b>
A	0.120	0.148
A1	0.078	-
b	0.014	0.020
C	0.007	0.011
D	0.700	0.730
e	0.050 BSC	
E	0.335 BSC	
E1	0.292	0.300
E2	0.267 BSC	
Q	0.025	-

**SOJ SMALL OUTLINE IC PACKAGE**

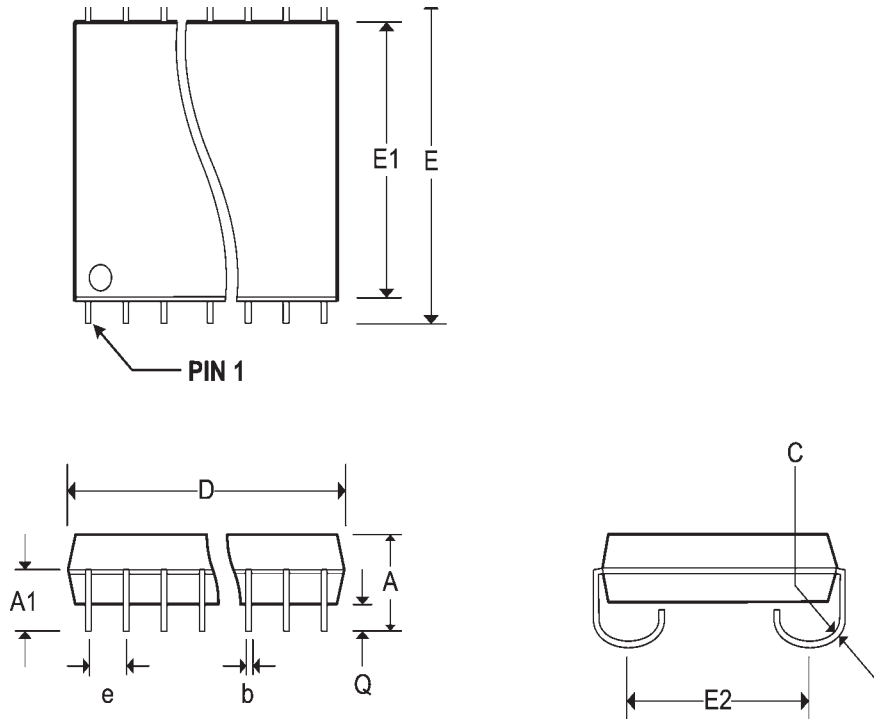

Pkg #	<b>P5</b>	
# Pins	28 (300 mil)	
Symbol	<b>Min</b>	<b>Max</b>
A	-	0.210
A1	-	-
b	0.014	0.023
b2	0.045	0.070
C	0.008	0.014
D	1.345	1.400
E1	0.270	0.300
E	0.300	0.380
e	0.100 BSC	
eB	-	0.430
L	0.115	0.150
$\alpha$	0°	15°

**PLASTIC DUAL IN-LINE PACKAGE**

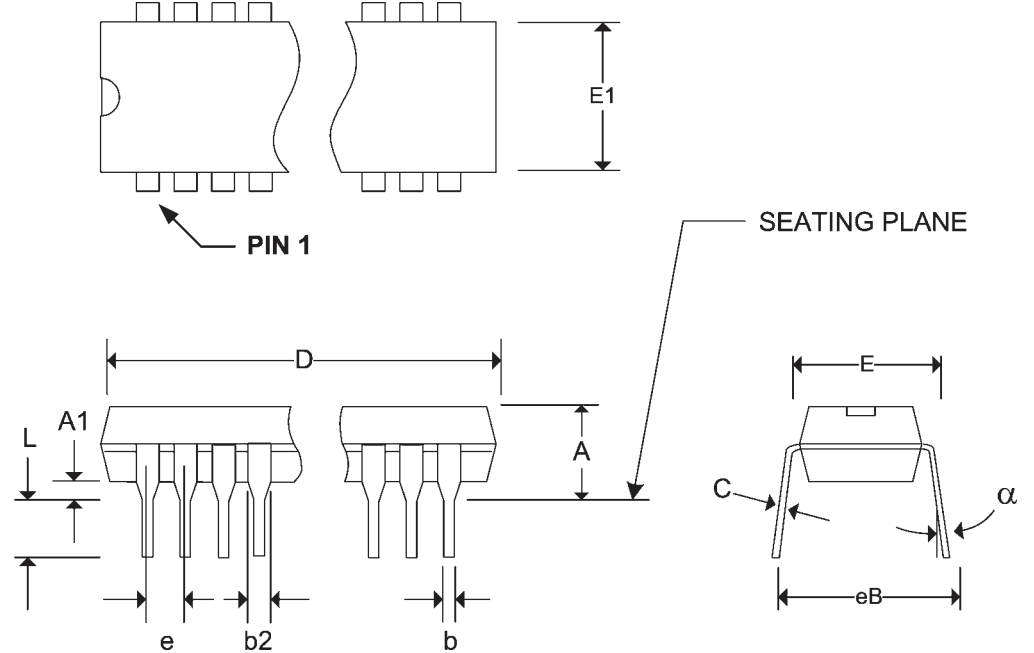

Pkg #	<b>L5</b>	
# Pins	28	
Symbol	<b>Min</b>	<b>Max</b>
A	0.060	0.075
A1	0.050	0.065
B1	0.022	0.028
D	0.342	0.358
D1	0.200 BSC	
D2	0.100 BSC	
D3	-	0.358
E	0.540	0.560
E1	0.400 BSC	
E2	0.200 BSC	
E3	-	0.558
e	0.050 BSC	
h	0.040 REF	
j	0.020 REF	
L	0.045	0.055
L1	0.045	0.055
L2	0.075	0.095
ND	5	
NE	9	

**RECTANGULAR LEADLESS CHIP CARRIER**

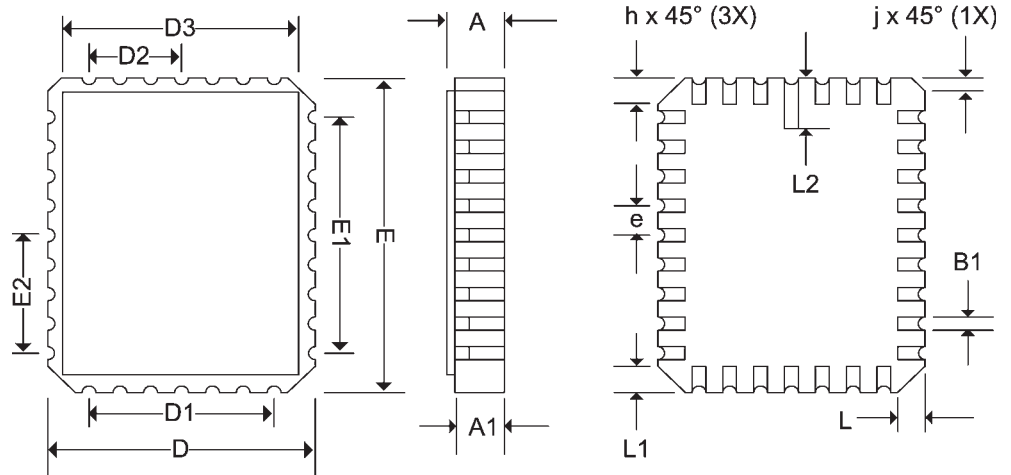

Pkg #	<b>C5</b>	
# Pins	28 (300 mil)	
Symbol	<b>Min</b>	<b>Max</b>
A	-	0.225
b	0.014	0.026
b2	0.045	0.065
C	0.008	0.018
D	-	1.485
E	0.240	0.310
eA	0.300 BSC	
e	0.100 BSC	
L	0.125	0.200
Q	0.015	0.070
S1	0.005	-
S2	0.005	-

**SIDEBRAZED DUAL IN-LINE PACKAGE**

