

# P4C163/P4C163L ULTRA HIGH SPEED 8K x 9 STATIC CMOS RAMS

## FEATURES

- Full CMOS, 6T Cell
- High Speed (Equal Access and Cycle Times)
  - 25/35ns (Commercial)
  - 25/35/45ns (Military)
- Low Power Operation (Commercial/Military)
- Output Enable and Dual Chip Enable Control Functions
- Single 5V±10% Power Supply
- Data Retention with 2.0V Supply, 10 µA Typical Current (P4C163L Military)
- Common I/O
- Fully TTL Compatible Inputs and Outputs
- Standard Pinout (JEDEC Approved)
  - 28-Pin 300 mil DIP, SOJ
  - 28-Pin 350 x 550 mil LCC
  - 28-Pin CERPACK

## DESCRIPTION

The P4C163 and P4C163L are 73,728-bit ultra high-speed static RAMs organized as 8K x 9. The CMOS memories require no clocks or refreshing and have equal access and cycle times. Inputs are fully TTL-compatible. The RAMs operate from a single 5V±10% tolerance power supply. With battery backup, data integrity is maintained for supply voltages down to 2.0V. Current drain is 10 µA from a 2.0V supply.

Access times as fast as 25 nanoseconds are available, permitting greatly enhanced system operating speeds. CMOS is used to reduce power consumption in both active and standby modes.

The P4C163 and P4C163L are available in 28-pin 300 mil DIP and SOJ, 28-pin 350 x 550 mil LCC, and 28-pin CERPACK packages providing excellent board level densities.

## FUNCTIONAL BLOCK DIAGRAM

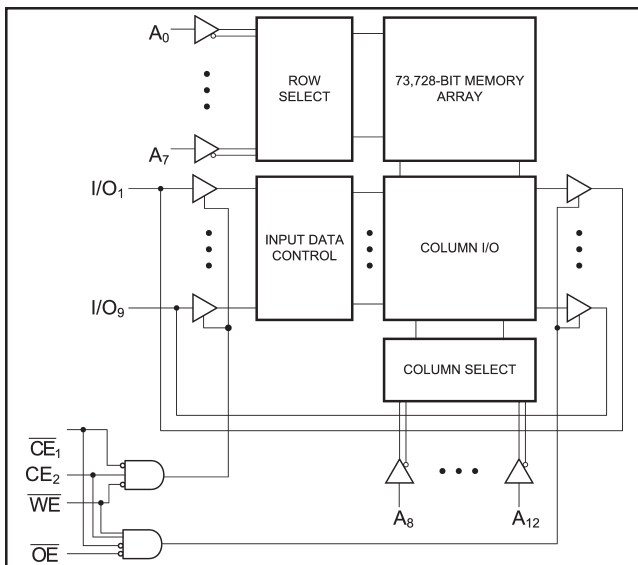

## PIN CONFIGURATIONS

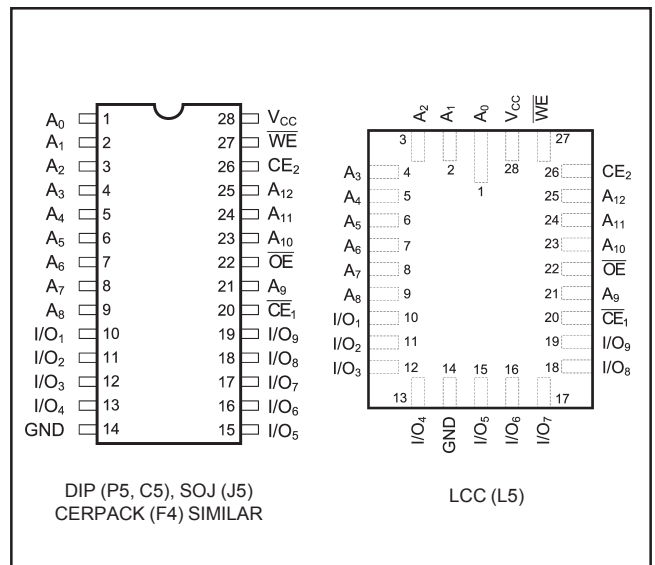

## MAXIMUM RATINGS<sup>(1)</sup>

Symbol	Parameter	Value	Unit
$V_{CC}$	Power Supply Pin with Respect to GND	-0.5 to +7	V
$V_{TERM}$	Terminal Voltage with Respect to GND (up to 7.0V)	-0.5 to $V_{CC} + 0.5$	V
$T_A$	Operating Temperature	-55 to +125	°C

Symbol	Parameter	Value	Unit
$T_{BIAS}$	Temperature Under Bias	-55 to +125	°C
$T_{STG}$	Storage Temperature	-65 to +150	°C
$P_T$	Power Dissipation	1.0	W
$I_{OUT}$	DC Output Current	50	mA

## RECOMMENDED OPERATING TEMPERATURE AND SUPPLY VOLTAGE

Grade <sup>(2)</sup>	Ambient Temperature	GND	$V_{CC}$
Military	-55 to +125°C	0V	5.0V ± 10%

Grade <sup>(2)</sup>	Ambient Temperature	GND	$V_{CC}$
Commercial	0°C to +70°C	0V	5.0V ± 10%

## DC ELECTRICAL CHARACTERISTICS

Over recommended operating temperature and supply voltage<sup>(2)</sup>

Symbol	Parameter	Test Conditions	P4C163		P4C163L		Unit
			Min	Max	Min	Max	
$V_{IH}$	Input High Voltage		2.2	$V_{CC} + 0.5$	2.2	$V_{CC} + 0.5$	V
$V_{IL}$	Input Low Voltage		-0.5 <sup>(3)</sup>	0.8	-0.5 <sup>(3)</sup>	0.8	V
$V_{HC}$	CMOS Input High Voltage		$V_{CC} - 0.2$	$V_{CC} + 0.5$	$V_{CC} - 0.2$	$V_{CC} + 0.5$	V
$V_{LC}$	CMOS Input Low Voltage		-0.5 <sup>(3)</sup>	0.2	-0.5 <sup>(3)</sup>	0.2	V
$V_{CD}$	Input Clamp Diode Voltage	$V_{CC} = \text{Min.}, I_{IN} = -18 \text{ mA}$		-1.2		-1.2	V
$V_{OL}$	Output Low Voltage (TTL Load)	$I_{OL} = +8 \text{ mA}, V_{CC} = \text{Min.}$		0.4		0.4	V
$V_{OLC}$	Output Low Voltage (CMOS Load)	$I_{OLC} = +100 \mu\text{A}, V_{CC} = \text{Min.}$		0.2		0.2	V
$V_{OH}$	Output High Voltage (TTL Load)	$I_{OH} = -4 \text{ mA}, V_{CC} = \text{Min.}$	2.4		2.4		V
$V_{OHC}$	Output High Voltage (CMOS Load)	$I_{OHC} = -100 \mu\text{A}, V_{CC} = \text{Min.}$	$V_{CC} - 0.2$		$V_{CC} - 0.2$		V
$I_{LI}$	Input Leakage Current	$V_{CC} = \text{Max.}, V_{IN} = \text{GND to } V_{CC}$	Mil. -10 Com'l. -5	+10 +5	-5 N/A	+5 N/A	μA
$I_{LO}$	Output Leakage Current	$V_{CC} = \text{Max.}, \overline{CE} = V_{IH}, V_{OUT} = \text{GND to } V_{CC}$	Mil. -10 Com'l. -5	+10 +5	-5 N/A	+5 N/A	μA

## CAPACITANCES<sup>(4)</sup>

( $V_{CC} = 5.0\text{V}, T_A = 25^\circ\text{C}, f = 1.0\text{MHz}$ )

Symbol	Parameter	Conditions	Typ.	Unit
$C_{IN}$	Input Capacitance	$V_{IN} = 0\text{V}$	5	pF

Symbol	Parameter	Conditions	Typ.	Unit
$C_{OUT}$	Output Capacitance	$V_{OUT} = 0\text{V}$	7	pF

### Notes:

- Stresses greater than those listed under MAXIMUM RATINGS may cause permanent damage to the device. This is a stress rating only and functional operation of the device at these or any other conditions above those indicated in the operational sections of this specification is not implied. Exposure to MAXIMUM rating conditions for extended periods may affect reliability.
- Extended temperature operation guaranteed with 400 linear feet per minute of air flow.
- Transient inputs with  $V_{IL}$  and  $I_{IL}$  not more negative than -3.0V and -100mA, respectively, are permissible for pulse widths up to 20 ns.
- This parameter is sampled and not 100% tested.

## POWER DISSIPATION CHARACTERISTICS

Over recommended operating temperature and supply voltage<sup>(2)</sup>

Symbol	Parameter	Test Conditions	P4C163		P4C163L		Unit	
			Min	Max	Min	Max		
$I_{CC}$	Dynamic Operating Current – 25	$V_{CC} = \text{Max.}, f = \text{Max.},$ Outputs Open	Mil. Com'l.	— —	145 125	— —	145 N/A	mA
$I_{CC}$	Dynamic Operating Current – 35, 45	$V_{CC} = \text{Max.}, f = \text{Max.},$ Outputs Open	Mil. Com'l.	— —	120 95	— —	120 N/A	mA
$I_{SB}$	Standby Power Supply Current (TTL Input Levels)	$\overline{CE}_1 \geq V_{IH}$ or $CE_2 \leq V_{IL}, V_{CC} = \text{Max.},$ $f = \text{Max.},$ Outputs Open	Mil. Com'l.	— —	40 35	— —	40 N/A	mA
$I_{SB1}$	Standby Power Supply Current (CMOS Input Levels)	$\overline{CE}_1 \geq V_{HC}$ or $CE_2 \leq V_{LC}, V_{CC} = \text{Max.},$ $f = 0,$ Outputs Open, $V_{IN} \leq V_{LC}$ or $V_{IN} \geq V_{HC}$	Mil. Com'l.	— —	20 18	— —	1 N/A	mA

n/a = Not Applicable

## DATA RETENTION CHARACTERISTICS (P4C163L, Military Temperature Only)

Symbol	Parameter	Test Condition	Min	Typ.* $V_{CC} =$		Max $V_{CC} =$		Unit
				2.0V	3.0V	2.0V	3.0V	
$V_{DR}$	$V_{CC}$ for Data Retention		2.0					V
$I_{CCDR}$	Data Retention Current	$\overline{CE}_1 \geq V_{CC} - 0.2V$ or $CE_2 \leq 0.2V, V_{IN} \geq V_{CC} - 0.2V$ or $V_{IN} \leq 0.2V$		10	15	200	300	$\mu A$
$t_{CDR}$	Chip Deselect to Data Retention Time		0					ns
$t_R^\dagger$	Operation Recovery Time		$t_{RC}^\S$					ns

\* $T_A = +25^\circ C$

$^\S t_{RC}$  = Read Cycle Time

$^\dagger$ This parameter is guaranteed but not tested.

## DATA RETENTION WAVEFORM

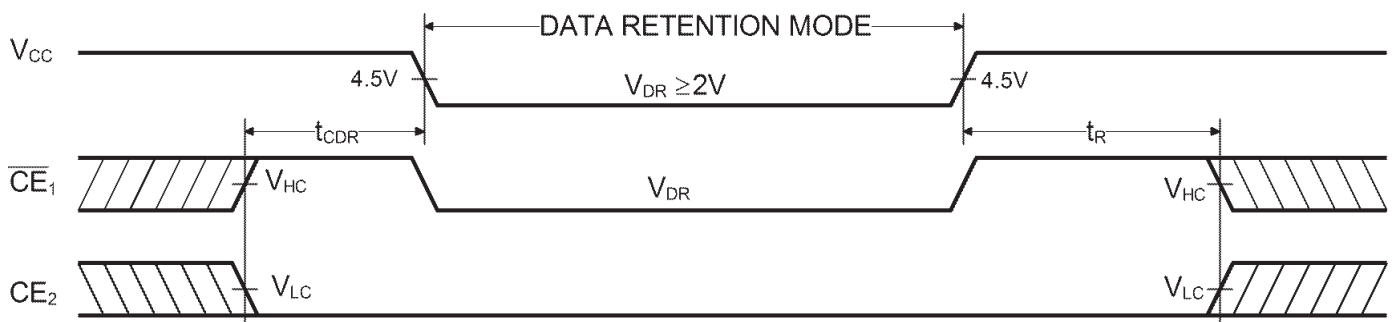

## AC ELECTRICAL CHARACTERISTICS—READ CYCLE

( $V_{CC} = 5V \pm 10\%$ , All Temperature Ranges)<sup>(2)</sup>

Symbol	Parameter	-25		-35		-45		Unit
		Min	Max	Min	Max	Min	Max	
$t_{RC}$	Read Cycle Time	25		35		45		ns
$t_{AA}$	Address Access Time		25		35		45	ns
$t_{AC}$	Chip Enable Access Time		25		35		45	ns
$t_{OH}$	Output Hold from Address Change	3		3		3		ns
$t_{LZ}$	Chip Enable to Output in Low Z	3		3		3		ns
$t_{HZ}$	Chip Disable to Output in High Z		10		15		20	ns
$t_{OE}$	Output Enable Low to Data Valid		13		18		20	ns
$t_{OLZ}$	Output Enable Low to Low Z	3		3		3		ns
$t_{OHZ}$	Output Enable High to High Z		12		15		20	ns
$t_{PU}$	Chip Enable to Power Up Time	0		0		0		ns
$t_{PD}$	Chip Disable to Power Down Time		20		20		25	ns

### READ CYCLE NO. 1 ( $\overline{OE}$ CONTROLLED)<sup>(5)</sup>

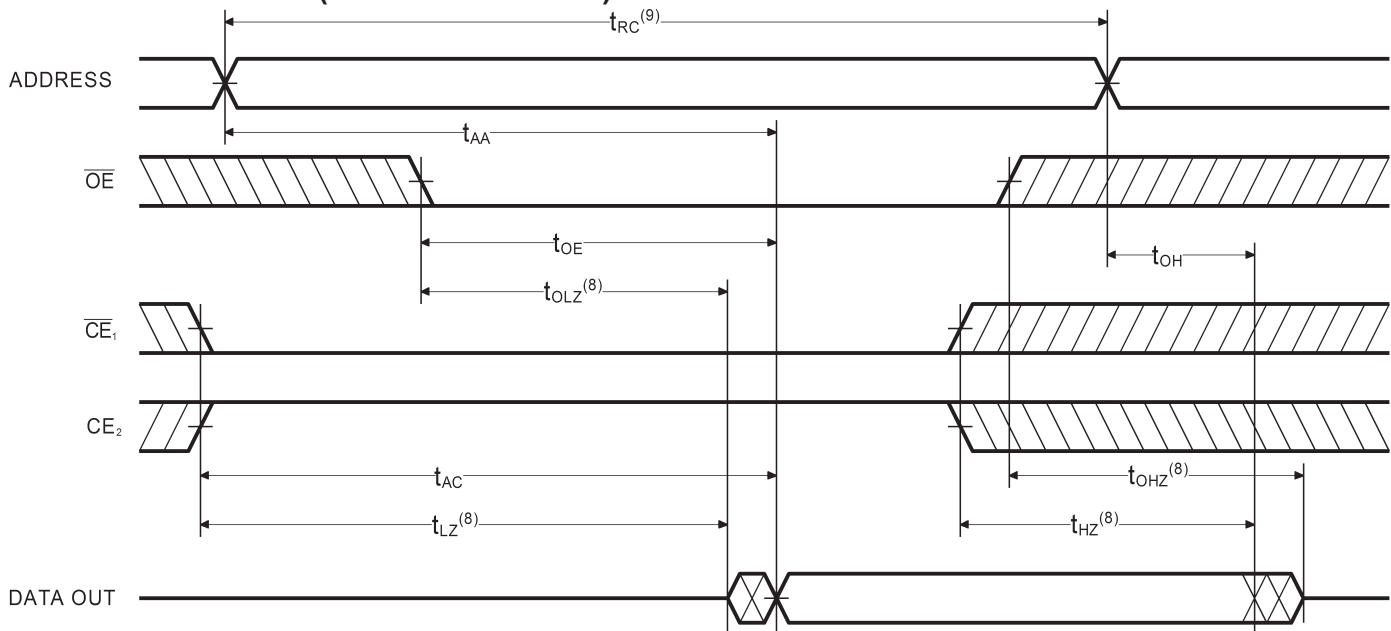

**Notes:**

- 5.  $\overline{WE}$  is HIGH for READ cycle.
- 6.  $\overline{CE}_1$  is LOW,  $CE_2$  is HIGH and  $\overline{OE}$  is LOW for READ cycle.
- 7. ADDRESS must be valid prior to, or coincident with  $\overline{CE}_1$  transition LOW and  $CE_2$  transition HIGH.

- 8. Transition is measured  $\pm 200mV$  from steady state voltage prior to change, with loading as specified in Figure 1. This parameter is sampled and not 100% tested.

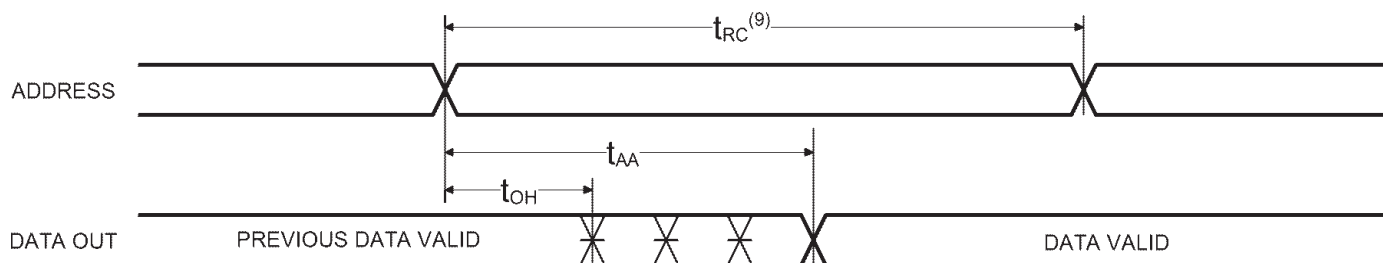
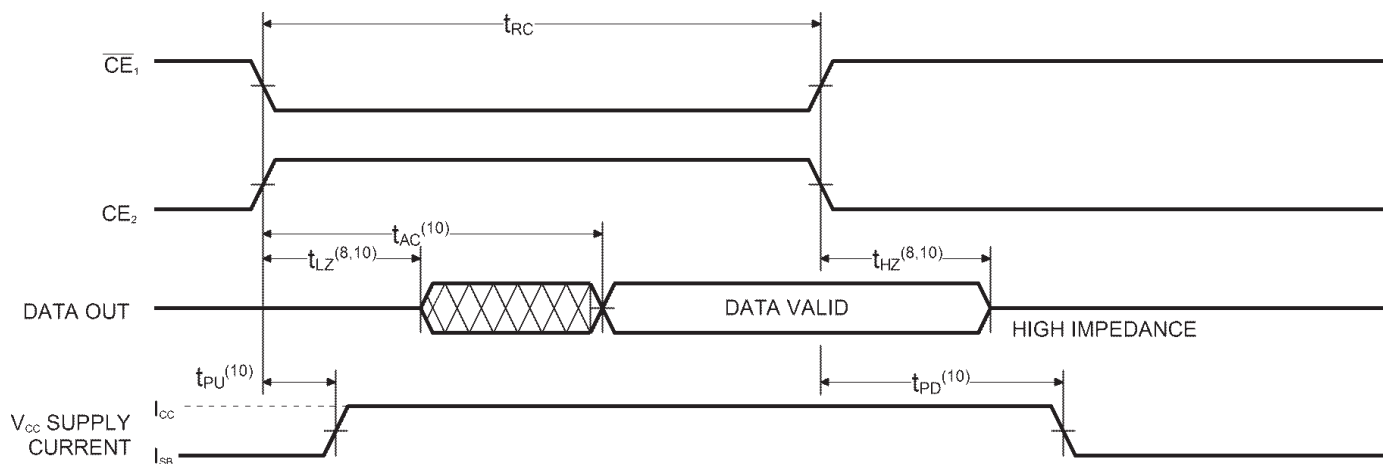
**READ CYCLE NO. 2 (ADDRESS CONTROLLED)<sup>(5,6)</sup>****READ CYCLE NO. 3 ( $\overline{CE}_1$ ,  $CE_2$  CONTROLLED)<sup>(5,7,10)</sup>****Notes:**

9. READ Cycle Time is measured from the last valid address to the first transitioning address.

10. Transitions caused by a chip enable control have similar delays irrespective of whether  $\overline{CE}_1$  or  $CE_2$  causes them.

## AC CHARACTERISTICS—WRITE CYCLE

( $V_{CC} = 5V \pm 10\%$ , All Temperature Ranges)<sup>(2)</sup>

Symbol	Parameter	-25		-35		-45		Unit
		Min	Max	Min	Max	Min	Max	
$t_{WC}$	Write Cycle Time	25		35		45		ns
$t_{CW}$	Chip Enable Time to End of Write	18		25		33		ns
$t_{AW}$	Address Valid to End of Write	18		25		33		ns
$t_{AS}$	Address Set-up Time	0		0		0		ns
$t_{WP}$	Write Pulse Width	18		20		25		ns
$t_{AH}$	Address Hold Time	0		0		0		ns
$t_{DW}$	Data Valid to End of Write	13		15		20		ns
$t_{DH}$	Data Hold Time	0		0		0		ns
$t_{WZ}$	Write Enable to Output in High Z		10		14		18	ns
$t_{OW}$	Output Active from End of Write	3		5		5		ns

### WRITE CYCLE NO. 1 ( $\overline{WE}$ CONTROLLED)<sup>(11)</sup>

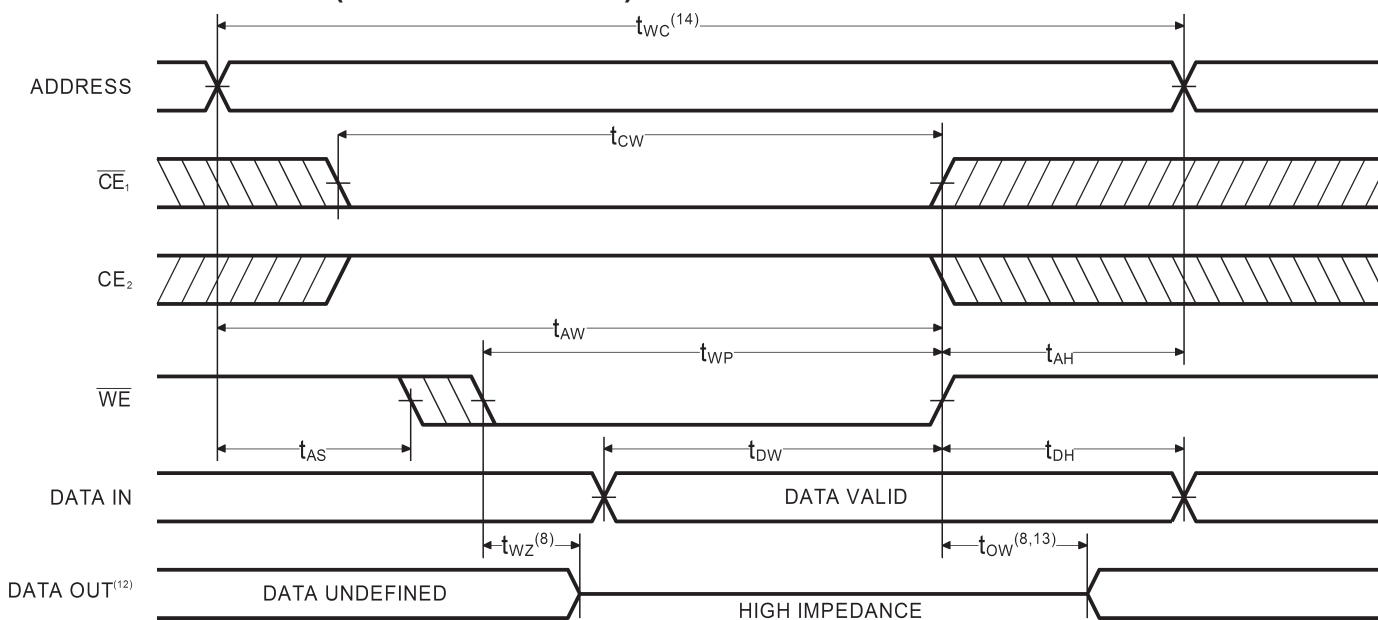

#### Notes:

11.  $\overline{CE}_1$  and  $\overline{WE}$  must be LOW, and  $CE_2$  HIGH for WRITE cycle.
12.  $\overline{OE}$  is LOW for this WRITE cycle to show  $t_{WZ}$  and  $t_{OW}$ .
13. If  $\overline{CE}_1$  goes HIGH, or  $CE_2$  goes LOW, simultaneously with  $\overline{WE}$  HIGH, the output remains in a low impedance state.
14. Write Cycle Time is measured from the last valid address to the first transitioning address.

### TIMING WAVEFORM OF WRITE CYCLE NO. 2 ( $\overline{CE}$ CONTROLLED)<sup>(11)</sup>

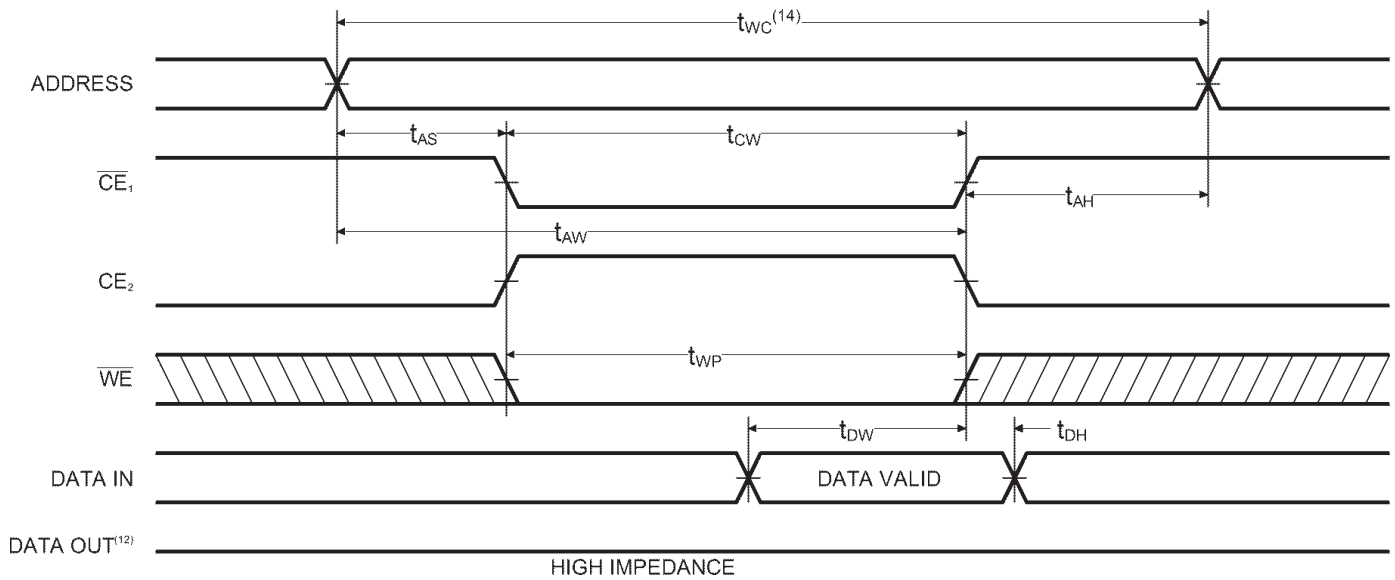

### AC TEST CONDITIONS

Input Pulse Levels	GND to 3.0V
Input Rise and Fall Times	3ns
Input Timing Reference Level	1.5V
Output Timing Reference Level	1.5V
Output Load	See Figures 1 and 2

### TRUTH TABLE

Mode	$\overline{CE}_1$	$CE_2$	$\overline{OE}$	$\overline{WE}$	I/O	Power
Standby	H	X	X	X	High Z	Standby
Standby	X	L	X	X	High Z	Standby
$D_{OUT}$ Disabled	L	H	H	H	High Z	Active
Read	L	H	L	H	$D_{OUT}$	Active
Write	L	H	X	L	$D_{IN}$	Active

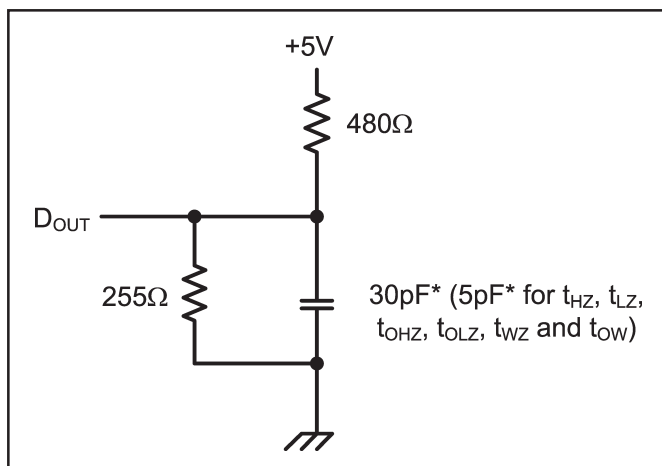

Figure 1. Output Load

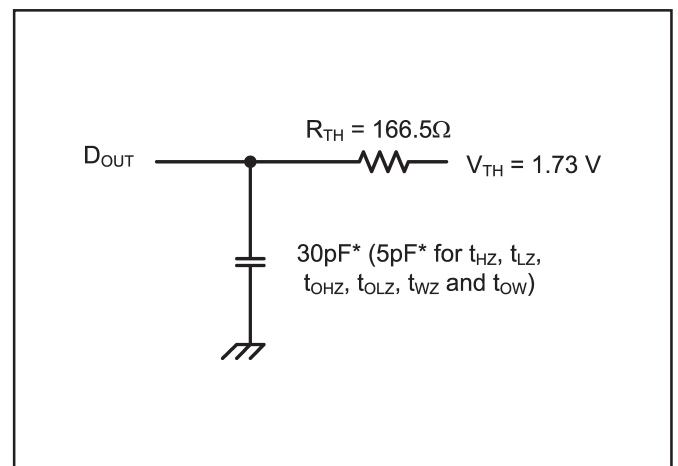

Figure 2. Thevenin Equivalent

\* including scope and test fixture.

**Note:**

Because of the ultra-high speed of the P4C163/L, care must be taken when testing this device; an inadequate setup can cause a normal functioning part to be rejected as faulty. Long high-inductance leads that cause supply bounce must be avoided by bringing the  $V_{CC}$  and ground planes directly up to the contactor fingers. A 0.01  $\mu$ F high frequency

capacitor is also required between  $V_{CC}$  and ground. To avoid signal reflections, proper termination must be used; for example, a 50 $\Omega$  test environment should be terminated into a 50 $\Omega$  load with 1.73V (Thevenin Voltage) at the comparator input, and a 116 $\Omega$  resistor must be used in series with  $D_{OUT}$  to match 166 $\Omega$  (Thevenin Resistance).

## ORDERING INFORMATION

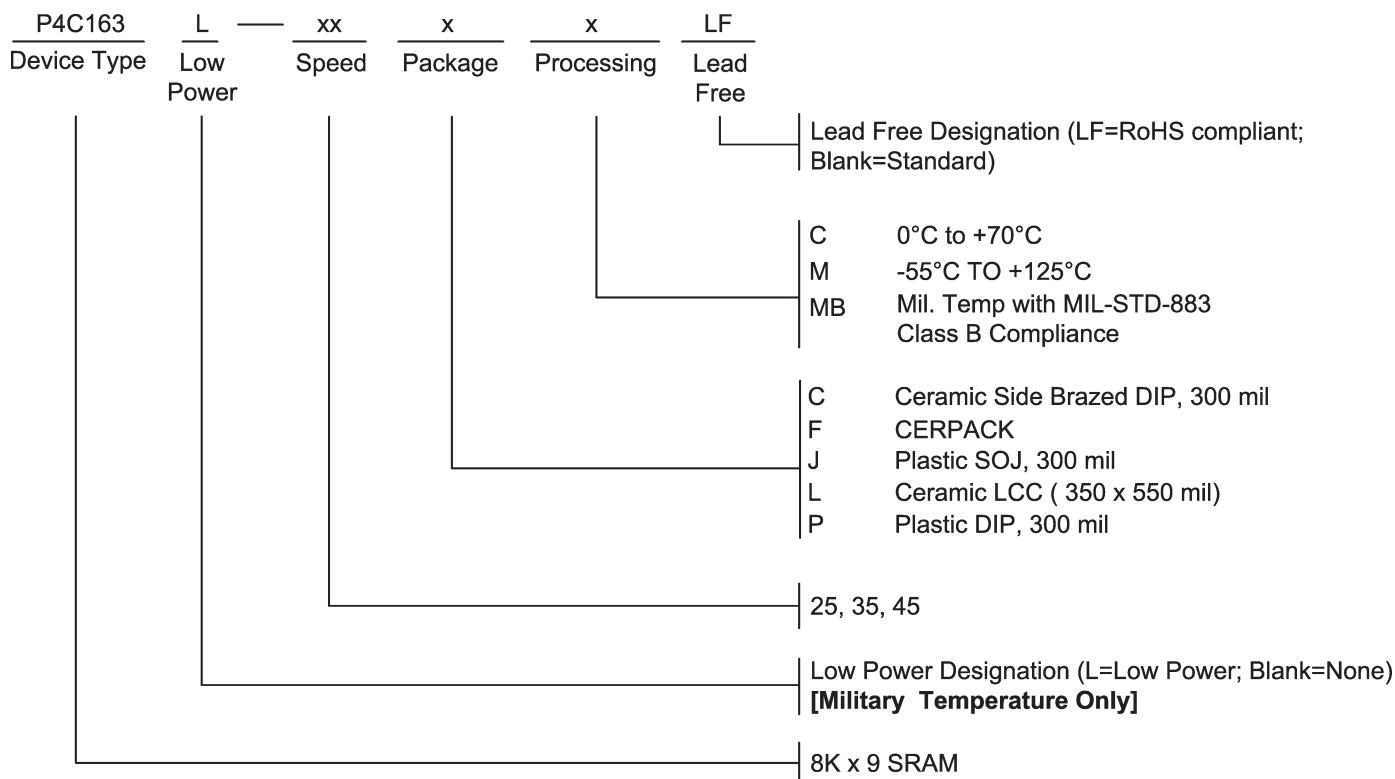

## SELECTION GUIDE

The P4C163/L is available in the following temperature, speed and package options. The P4C163L is only available over the military temperature range.

Temperature Range	Package	Speed		
		25	35	45
Commercial	Plastic DIP	-25PC	-35PC	N/A
	Plastic SOJ	-25JC	-35JC	N/A
Military Temperature	Side Brazed DIP	-25CM	-35CM	-45CM
	LCC	-25LM	-35LM	-45LM
	CERPACK	-25FM	-35FM	-45FM
Military Processed*	Side Brazed DIP	-25CMB	-35CMB	-45CMB
	LCC	-25LMB	-35LMB	-45LMB
	CERPACK	-25FMB	-35FMB	-45FMB

\* Military temperature range with MIL-STD-883, Class B processing.

N/A = Not available

Pkg #	<b>C5</b>	
# Pins	28 (300 mil)	
Symbol	Min	Max
A	-	0.225
b	0.014	0.026
b2	0.045	0.065
C	0.008	0.018
D	-	1.485
E	0.240	0.310
eA	0.300 BSC	
e	0.100 BSC	
L	0.125	0.200
Q	0.015	0.070
S1	0.005	-
S2	0.005	-

**SIDE BRAZED DUAL IN-LINE PACKAGE**

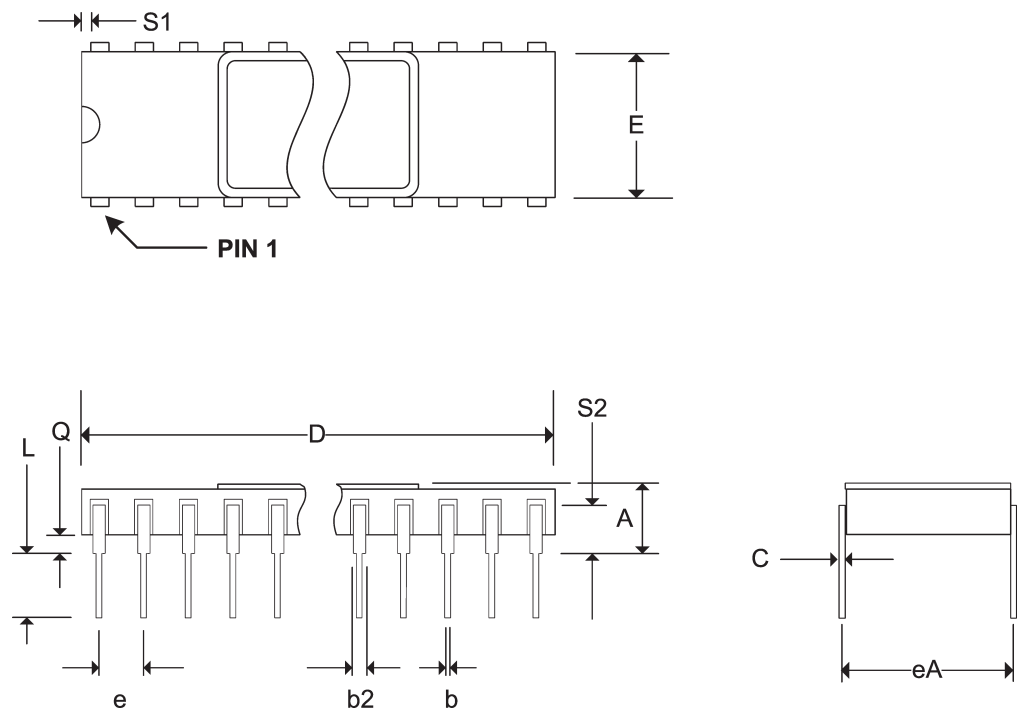

Pkg #	<b>F4</b>	
# Pins	28	
Symbol	Min	Max
A	0.060	0.090
b	0.015	0.022
c	0.004	0.009
D	-	0.730
E	0.330	0.380
e	0.050 BSC	
k	0.005	0.018
L	0.250	0.370
Q	0.026	0.045
S	-	0.085
S1	0.005	-

**CERPACK CERAMIC FLAT PACKAGE**

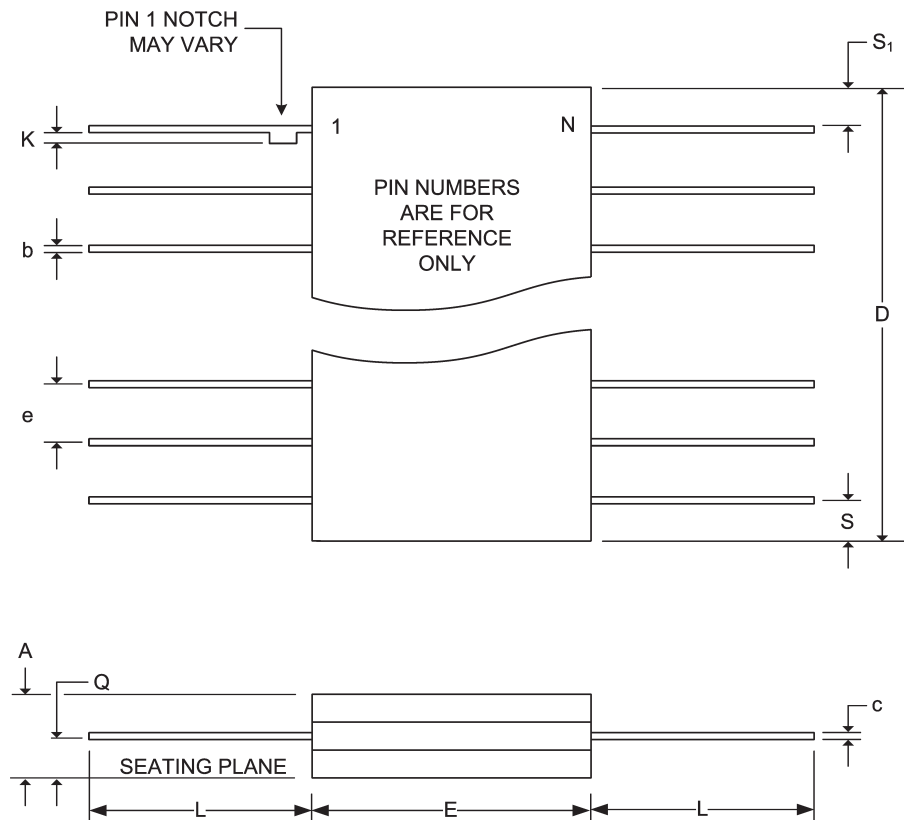

Pkg #	<b>J5</b>	
# Pins	28 (300 mil)	
Symbol	<b>Min</b>	<b>Max</b>
A	0.120	0.148
A1	0.078	-
b	0.014	0.020
C	0.007	0.011
D	0.700	0.730
e	0.050 BSC	
E	0.335 BSC	
E1	0.292	0.300
E2	0.267 BSC	
Q	0.025	-

**SOJ SMALL OUTLINE IC PACKAGE**

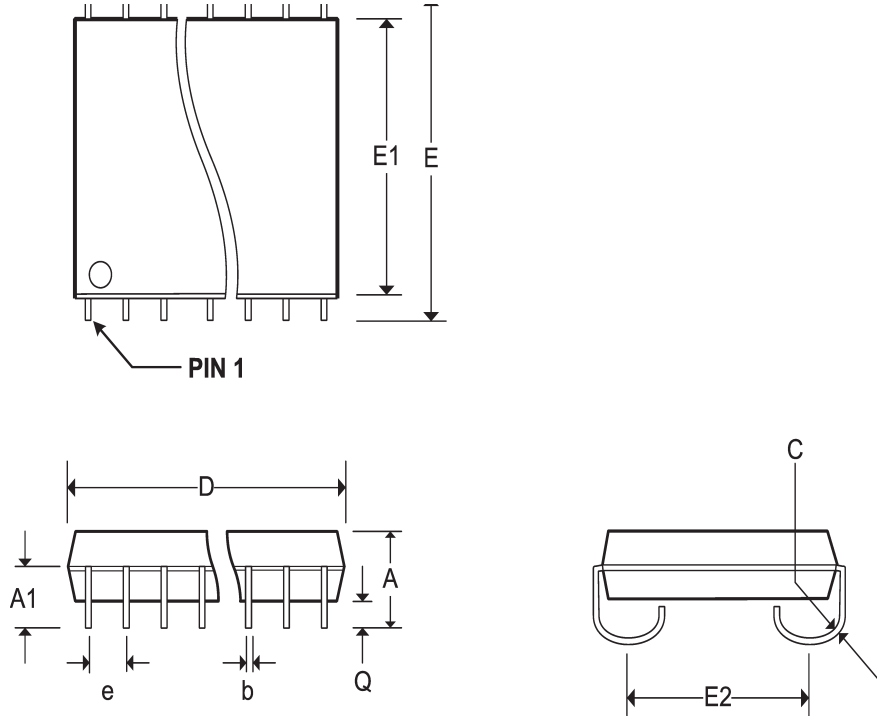

Pkg #	<b>L5</b>	
# Pins	28	
Symbol	<b>Min</b>	<b>Max</b>
A	0.060	0.075
A1	0.050	0.065
B1	0.022	0.028
D	0.342	0.358
D1	0.200 BSC	
D2	0.100 BSC	
D3	-	0.358
E	0.540	0.560
E1	0.400 BSC	
E2	0.200 BSC	
E3	-	0.558
e	0.050 BSC	
h	0.040 REF	
j	0.020 REF	
L	0.045	0.055
L1	0.045	0.055
L2	0.075	0.095
ND	5	
NE	9	

**RECTANGULAR LEADLESS CHIP CARRIER**

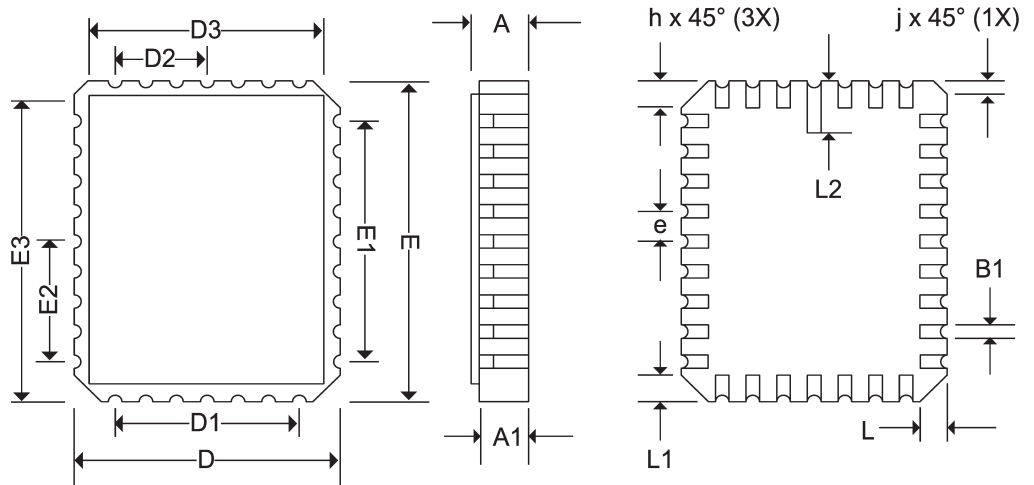

Pkg #	P5	
# Pins	28 (300 mil)	
Symbol	Min	Max
A	-	0.210
A1	-	-
b	0.014	0.023
b2	0.045	0.070
C	0.008	0.014
D	1.345	1.400
E1	0.270	0.300
E	0.300	0.380
e	0.100 BSC	
eB	-	0.430
L	0.115	0.150
$\alpha$	0°	15°

PLASTIC DUAL IN-LINE PACKAGE

