

THYRISTOR

150A Avg 800 Volts

**PDT1518
PDH1518**

■回路図 CIRCUIT

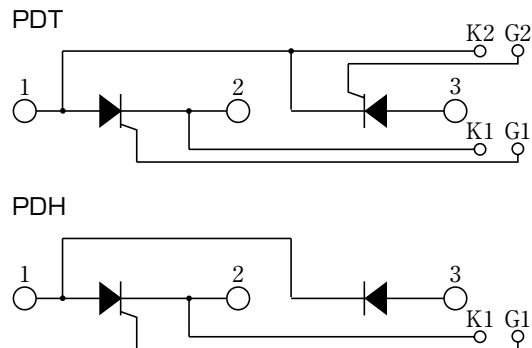

■外形寸法図 OUTLINE DRAWING (単位 Dimension : mm)

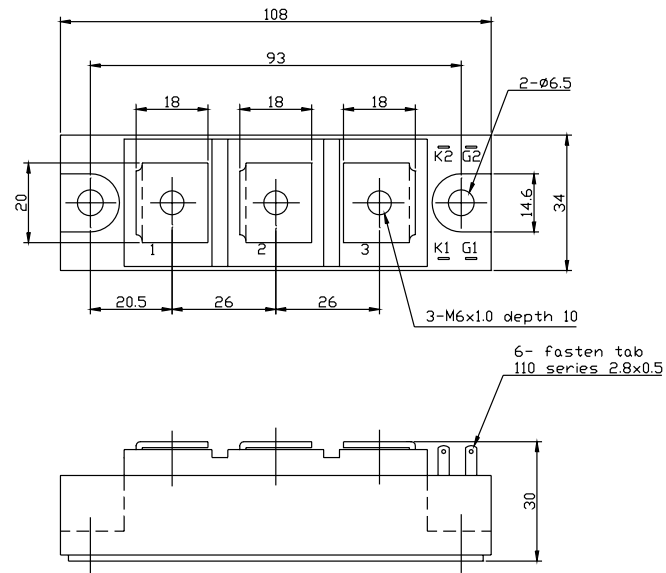

■最大定格 Maximum Ratings

項目 Parameter	記号 Symbol	耐圧クラス Grade	単位 Unit
		PDT1518/PDH1518	
くり返しピークオフ電圧 Repetitive Peak Off-State Voltage	V _{DRM}	800	V
非くり返しピークオフ電圧 Non Repetitive Peak Off-State Voltage	V _{DSM}	900	V
くり返しピーク逆電圧 Repetitive Peak Reverse Voltage	V _{RRM}	800	V
非くり返しピーク逆電圧 Non Repetitive Peak Reverse Voltage	V _{RSM}	900	V

項目 Parameter	記号 Symbol	条件 Conditions	定格値 Max. Rated Value	単位 Unit	
平均整流電流 Average Rectified Output Current	I _{O(AV)}	商用周波数 180° 通電 Half Sine Wave T _c = 76°C	150	A	
実効オン電流 RMS On-State Current	I _{T(RMS)}		235	A	
サージオン電流 Surge On-State Current	I _{TSM}	50Hz正弦半波, 1サイクル, 非くり返し Half Sine Wave, 1Pulse, Non-Repetitive	3200	A	
電流二乗時間積 I Squared t	I ² t	2 ~ 10ms	51200	A ² s	
臨界オン電流上昇率 Critical Rate of Rise of Turned-On Current	di/dt	V _D =2/3V _{DRM} , I _{TM} =2·I _O , T _j =125°C I _G =300mA, di _G /dt=0.2A/μs	100	A/μs	
ピークゲート電力損失 Peak Gate Power	P _{GM}		5	W	
平均ゲート電力損失 Average Gate Power	P _{G(AV)}		1	W	
ピークゲート電流 Peak Gate Current	I _{GM}		2	A	
ピークゲート電圧 Peak Gate Voltage	V _{GM}		10	V	
ピークゲート逆電圧 Peak Gate Reverse Voltage	V _{RGM}		5	V	
動作接合温度範囲 Operating Junction Temperature Range	T _{jw}		-40 ~ +125	°C	
保存温度範囲 Storage Temperature Range	T _{stg}		-40 ~ +125	°C	
絶縁耐圧 Isolation Voltage	V _{iso}	端子-裏面ベース間, AC 1分間 Terminal to Base, AC 1 min.	2500	V	
締付トルク Mounting Torque	ベース部 Mounting	サーマルコンパウンド塗布 Greased	M6	2.5~3.5	N·m
	主端子部 Terminal		M6	2.5~3.5	N·m

サイリスタモジュール

1アーム当りの値 Value Per 1 Arm.

■電気的特性 Electrical Characteristics

項目 Parameter	記号 Symbol	条件 Conditions	特性値 (最大) Maximum Value			単位 Unit
			最小 Min.	標準 Typ.	最大 Max.	
ピークオフ電流 Peak Off-State Current	I _{DM}	T _j =125°C, V _{DM} =V _{DRM}			15	mA
ピーク逆電流 Peak Reverse Current	I _{RM}	T _j =125°C, V _{RM} =V _{RRM}			15	mA
ピークオン電圧 Peak On-State Voltage	V _{TM}	T _j =25°C, I _{TM} =450A			1.36	V
トリガゲート電流 Gate Current to Trigger	I _{GT}	V _D =6V, I _T =1A	T _j = -40°C		300	mA
			T _j = 25°C		150	mA
			T _j = 125°C		80	mA
トリガゲート電圧 Gate Voltage to Trigger	V _{GT}	V _D =6V, I _T =1A	T _j = -40°C		5	V
			T _j = 25°C		3	V
			T _j = 125°C		2	V
非トリガゲート電圧 Gate Non-Trigger Voltage	V _{GD}	T _j =125°C, V _D =2/3V _{DRM}	0.25			V
臨界オフ電圧上昇率 Critical Rate of Rise of Off-State Voltage	dv/dt	T _j =125°C, V _D =2/3V _{DRM}	500			V/μs
ターンオフ時間 Turn-Off Time	t _q	T _j =125°C, I _{TM} =I _O , V _D =2/3V _{DRM} dv/dt=20V/μs, V _R =100V, -di/dt=20A/μs		100		μs
ターンオン時間 Turn-On Time	t _{gt}			6		μs
遅れ時間 Delay Time	t _d	T _j =25°C, V _D =2/3V _{DRM} I _G =300mA, di _G /dt=0.2A/μs		2		μs
立上がり時間 Rise Time	t _r			4		μs
ラッチング電流 Latching Current	I _L	T _j =25°C		100		mA
保持電流 Holding Current	I _H	T _j =25°C		60		mA
熱抵抗 Thermal Resistance	R _{th(j-c)}	接合部-ケース間 Junction to Case.			0.25	°C/W
接触熱抵抗 Thermal Resistance	R _{th(c-f)}	ケース-フィン間, サーマルコンパウンド塗布 Case to Fin, Greased			0.1	°C/W

質量…約280g
Approximate Weight

1アーム当りの値 Value Per 1 Arm.

■定格・特性曲線

オン電圧特性
ON-STATE CURRENT VS. VOLTAGE

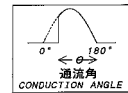
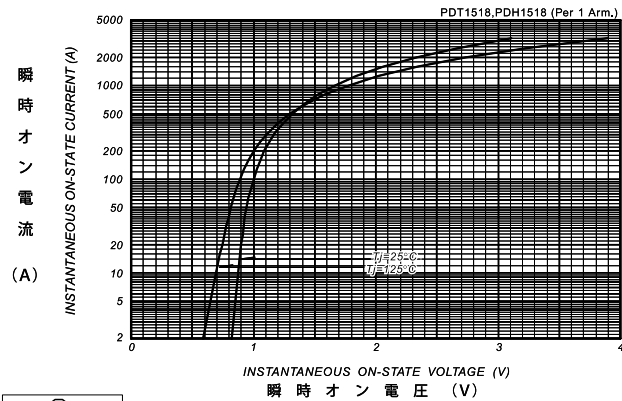

平均オン電力損失特性
AVERAGE ON-STATE POWER DISSIPATION
for SINUSOIDAL CURRENT WAVEFORM

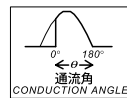
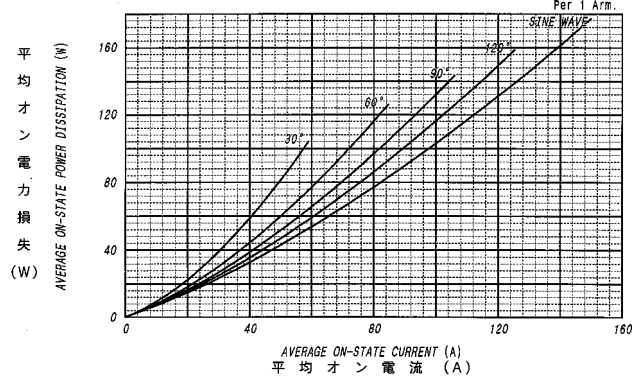

平均オン電流-ケース温度定格
AVERAGE ON-STATE CURRENT VS. CASE TEMPERATURE
(50Hz SINUSOIDAL CURRENT WAVEFORM)

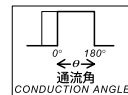
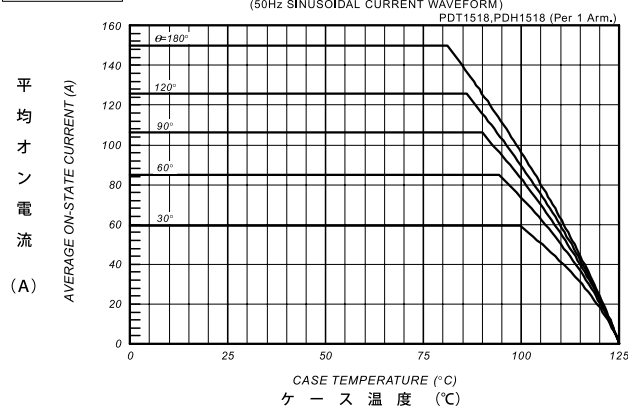

平均オン電流-ケース温度定格
AVERAGE ON-STATE CURRENT VS. CASE TEMPERATURE
(50Hz RECTANGULAR CURRENT WAVEFORM)

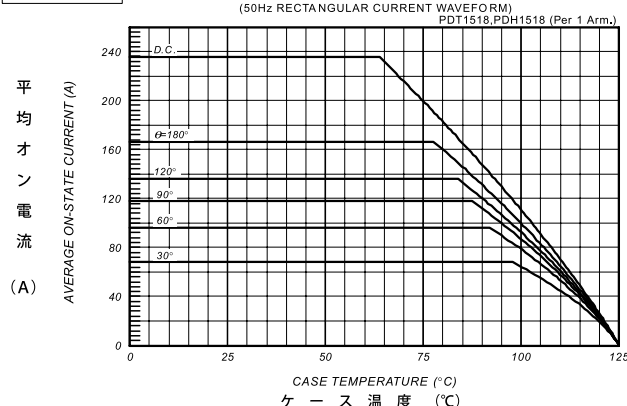

サージオン電流定格
SURGE CURRENT RATINGS

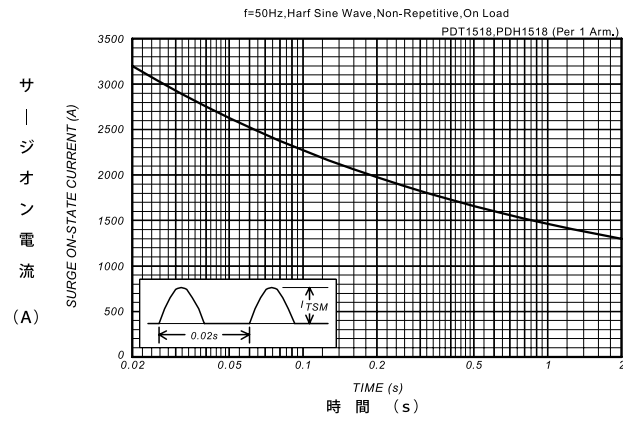

ゲート定格
GATE RATINGS

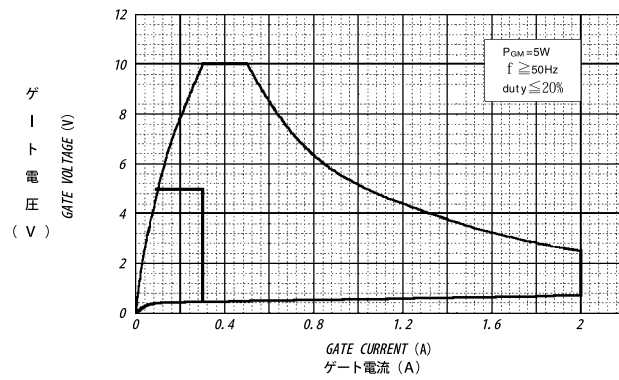

ゲート特性
GATE CHARACTERISTICS

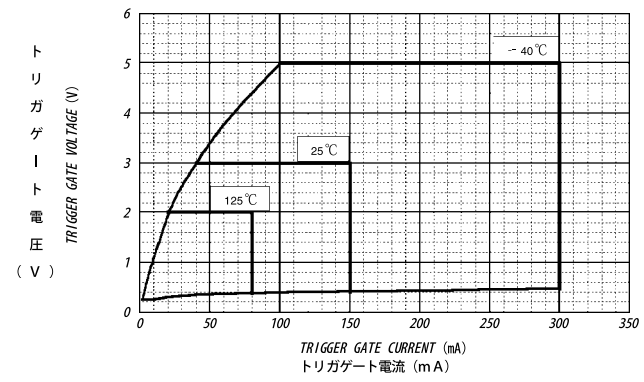

過渡熱抵抗特性
MAXIMUM TRANSIENT THERMAL IMPEDANCE

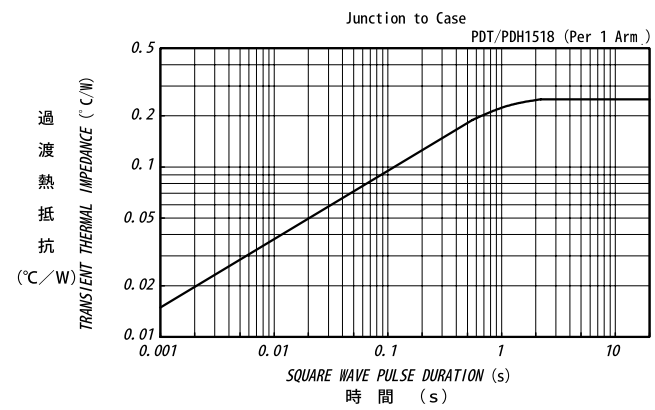

サイリスタモジュール