

10A Avg.

600 Volts

FRED

TCU10A60

最大定格 Maximum Ratings

Item	Symbol	Conditions	Unit
くり返しピーク逆電圧 Repetitive Peak Reverse Voltage	$V_{RRM}$	600	V
平均整流電流 Average Rectified Forward Current	$I_O$	50Hz, 正弦全波通電抵抗負荷 50Hz Full Sine Wave Resistive Load $T_c=84^\circ C$	10 A
実効順電流 R.M.S. Forward Current	$I_F(RMS)$	11.1	A
サージ順電流 Surge Forward Current	$I_{FSM}$	70 50Hz正弦全波, 1サイクル, 非くり返し 50Hz Full Sine Wave, 1cycle, Non-repetitive	A
動作接合温度範囲 Operating Junction Temperature Range	$T_{jw}$	-40~+150	$^\circ C$
保存温度範囲 Storage Temperature Range	$T_{stg}$	-40~+150	$^\circ C$

OUTLINE DRAWING(mm)

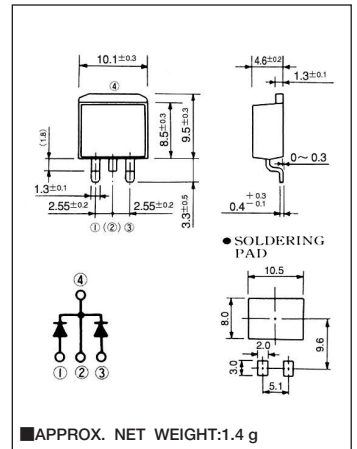

電氣的・熱的特性 Electrical/Thermal Characteristics

Item	Symbol	Conditions	Min.	Typ.	Max.	Unit
ピーク逆電流 Peak Reverse Current	$I_{RM}$	$T_j=25^\circ C, V_{RM}=V_{RRM}$ , 一素子あたり Per Diode	—	—	30	$\mu A$
ピーク順電圧 Peak Forward Voltage	$V_{FM}$	$T_j=25^\circ C, I_{FM}=5A$ , 一素子あたり Per Diode	—	1.9	2.3	V
逆回復時間 Reverse Recovery Time	$t_{rr}$	$I_{FM}=5A, -di/dt=50 A/\mu s, T_j=25^\circ C$	—	25	35	ns
熱抵抗 Thermal Resistance	$R_{th(j-c)}$	接合部・ケース間 Junction to Case	—	—	3	$^\circ C/W$

定格・特性曲線

