

10A Avg.

400 Volts

FRED

TCU10A40

最大定格 Maximum Ratings

Item	Symbol	Conditions	Unit
くり返しピーク逆電圧 Repetitive Peak Reverse Voltage	V_{RRM}	400	V
平均整流電流 Average Rectified Forward Current	I_O	50Hz正弦全波, 抵抗負荷 50Hz Full Sine Wave, Resistance Load $T_c = 104^\circ\text{C}$	10 A
実効順電流 R.M.S. Forward Current	$I_F(\text{RMS})$	11.1	A
サージ順電流 Surge Forward Current	I_{FSM}	80 50Hz正弦全波, 1サイクル, 非くり返し 50Hz Full Sine Wave, 1cycle, Non-repetitive	A
動作接合温度範囲 Operating Junction Temperature Range	T_{jw}	-40~+150	$^\circ\text{C}$
保存温度範囲 Storage Temperature Range	T_{stg}	-40~+150	$^\circ\text{C}$

OUTLINE DRAWING(mm)

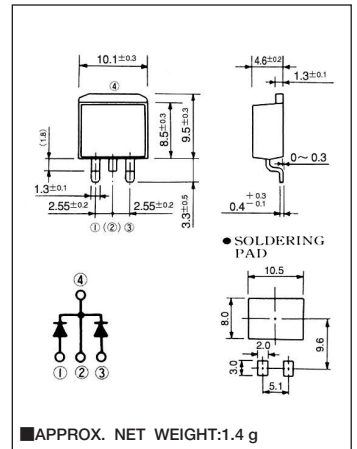

電氣的・熱的特性 Electrical/Thermal Characteristics

Item	Symbol	Conditions	Min.	Typ.	Max.	Unit
ピーク逆電流 Peak Reverse Current	I_{RM}	$T_j = 25^\circ\text{C}$, $V_{RM} = V_{RRM}$, 一素子あたり Per Diode	—	—	30	μA
ピーク順電圧 Peak Forward Voltage	V_{FM}	$T_j = 25^\circ\text{C}$, $I_{FM} = 5\text{A}$, 一素子あたり Per Diode	—	1.34	1.53	V
逆回復時間 Reverse Recovery Time	t_{rr}	$I_{FM} = 5\text{A}$, $-di/dt = 50\text{A}/\mu\text{s}$, $T_j = 25^\circ\text{C}$	—	22	32	ns
熱抵抗 Thermal Resistance	$R_{th(j-c)}$	接合部・ケース間 Junction to Case	—	—	3	$^\circ\text{C}/\text{W}$

定格・特性曲線

FIG.1

順電圧特性
FORWARD CURRENT VS. VOLTAGE

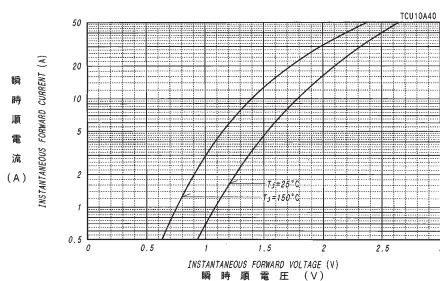

FIG.2

平均順電力損失特性
AVERAGE FORWARD POWER DISSIPATION

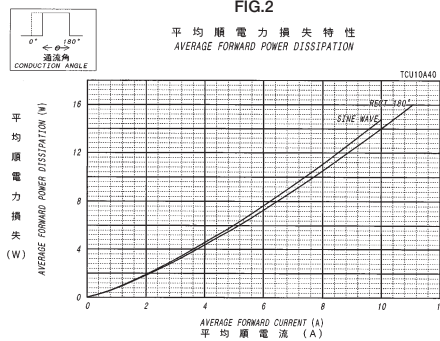

FIG.3

平均順電流-ケース温度定格
AVERAGE FORWARD CURRENT VS. CASE TEMPERATURE

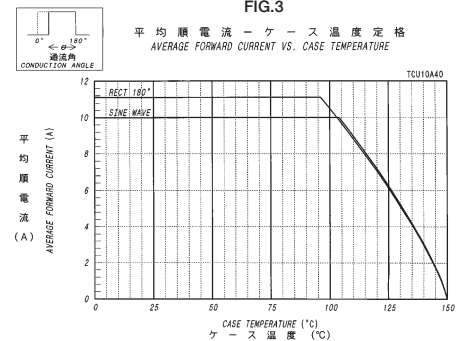

FIG.4

サージ順電流定格
SURGE CURRENT RATINGS

f=50Hz, Sine Wave, Non-Repetitive, No Load

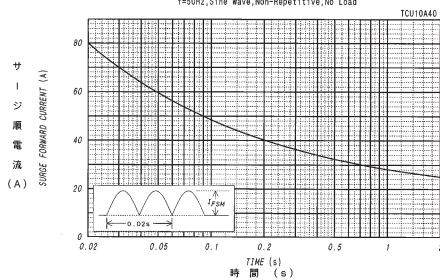

FIG.5

サージ実効順電流定格
SURGE RMS CURRENT RATINGS

TCU10A40

